

7/S1
v 3.1 (en)

FIRE DAMPER

FD25/40, FDC25/40





FIRE DAMPER FDC25/40

- Used for the isolation of duct penetrations between fire compartments.
- Fire dampers consist of housing, fire-resistant damper blade and release mechanism.
- Casing made of galvanized sheet steel, damper blade made of special insulating material, damper blade shaft and push rod made of galvanized steel, bearings made of brass, seals made of polyurethane and elastomer.
- Closed blade air leakage according to EN 1751, class 2
- Casing air leakage to EN 1751, class C
- Fire damper can be equipped with thermic fuse with 72°C or for warm air ventilation systems 95°C release temperature
- Fire damper casing is manufactured from galvanized steel, but on demand can be made from:
 - Galvanized steel and powder coated
 - Stainless steel
 - Stainless steel and powder coated
 - Fire damper for areas with potentially explosive atmospheres are also available (for additional information see FD-Ex catalog)

Dimensions

Ø _n [mm]	FDC25							FDC40						
	100	125	160	200	250	300	315	355	400	450	500	630	710	800

FIRE CLASSIFICATION (according to EN 13501-3)

Fire resistance of fire damper depends on classification of walls or ceilings. It is allowed to install products to walls or ceilings only according to products Declaration of Performance. Walls or ceilings with greater fire resistance can also be used. Fire damper should be installed according installation manual which can be found within this document.

Please consult latest Declaration of Performance on our website: www.klimaoprema.hr

SELECTION DIAGRAM

Symbol:

- v - air velocity in the duct [m/s]
- Δp_t - total pressure loss [Pa]
- L_{WA} - sound power level [dB(A)]

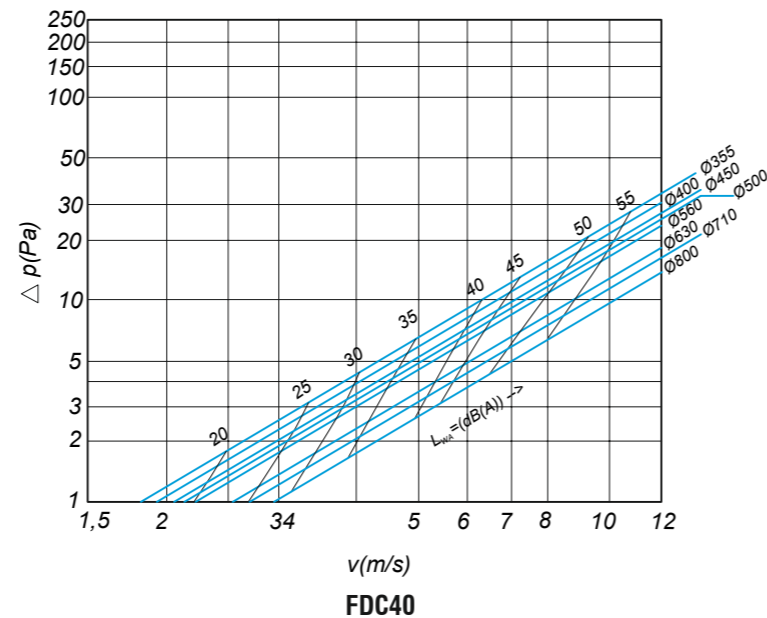
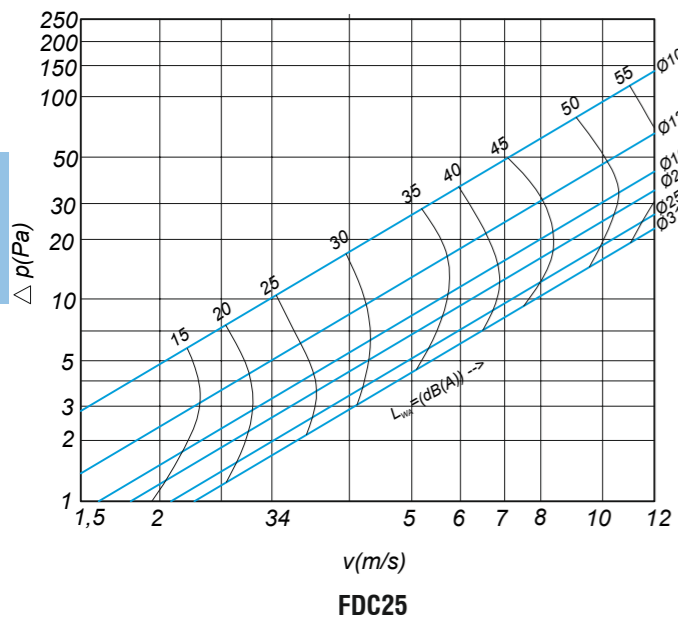

ORDERING KEY

Damper type: FDC25 - Ø250 - M230-S
FDC40

Damper dimensions
Ø [mm]

Mechanism type:

- R** - manual drive
- R-S** - manual drive with limit switches
- M230-S** - electric actuator AC230V
- M24-S** - electric actuator AC/DC 24V
- M24-S-ST** - electric actuator AC/DC 24V with connection plug
- EMS-S** - electromagnetic drive, permanent
- EMP-S** - electromagnetic drive, interruptive

DAMPER MODELS

FDC25 / FDC40 - R (manual mechanism)

- automatic closure when the temperature in the duct exceed 72°C
- manual rearmation with handle
- manual unlocking possible for periodical test of fire damper

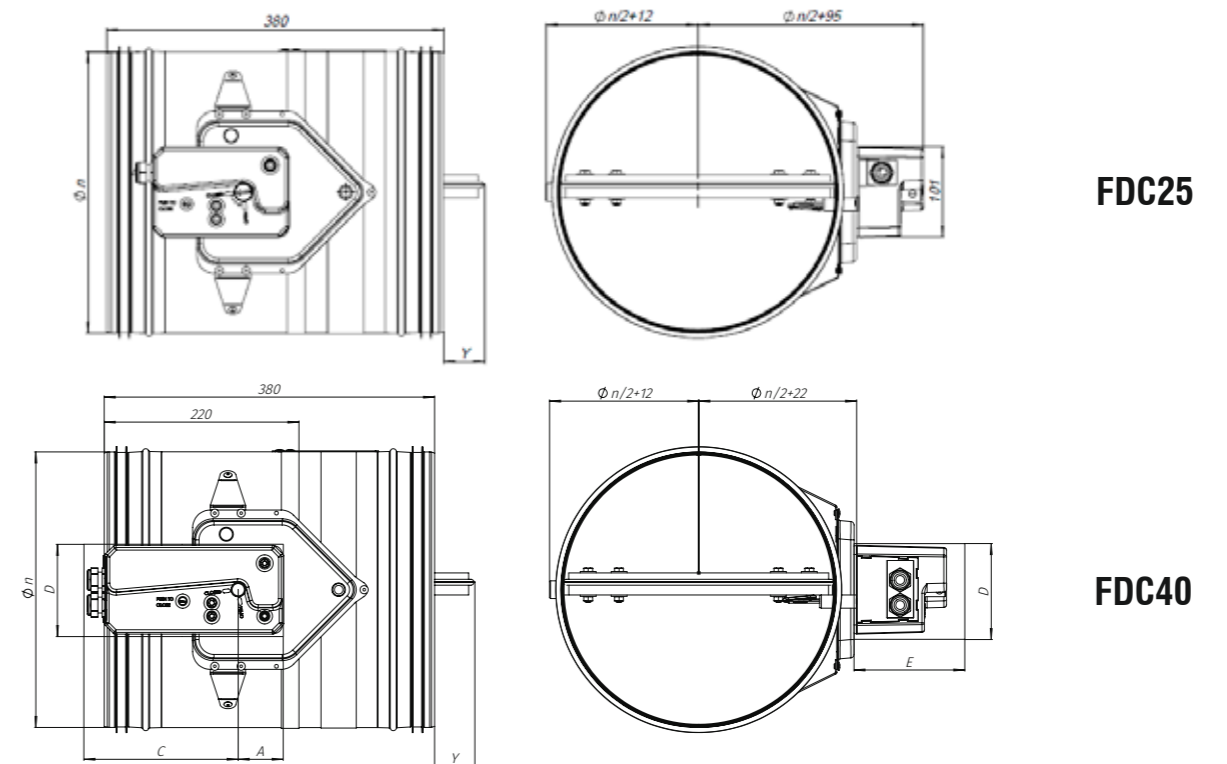

FDC25 / FDC40 -EMS/EMP (solenoid actuator)

- spring return actuator with integrated limit switches and thermoelectric release mechanism (72°C)
- manual rearmation with handle
- possible closing with solenoid
- manual closing possible

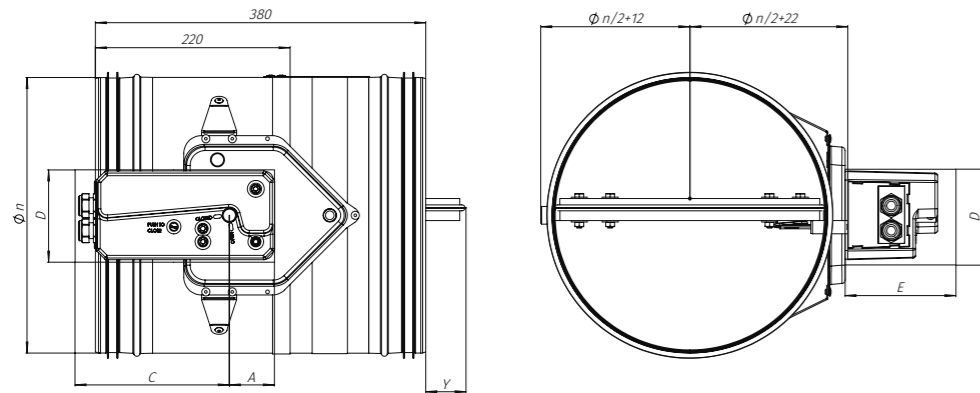

FDC25 / FDC40 -M (electric actuator)

- Thermoelectric activation (72°C) with electric actuator and return spring
- Integrated end switches
- Fully automatic operation

Options:

- M230 – electric actuator AC 230V
- M24 – electric actuator AC/DC 24V

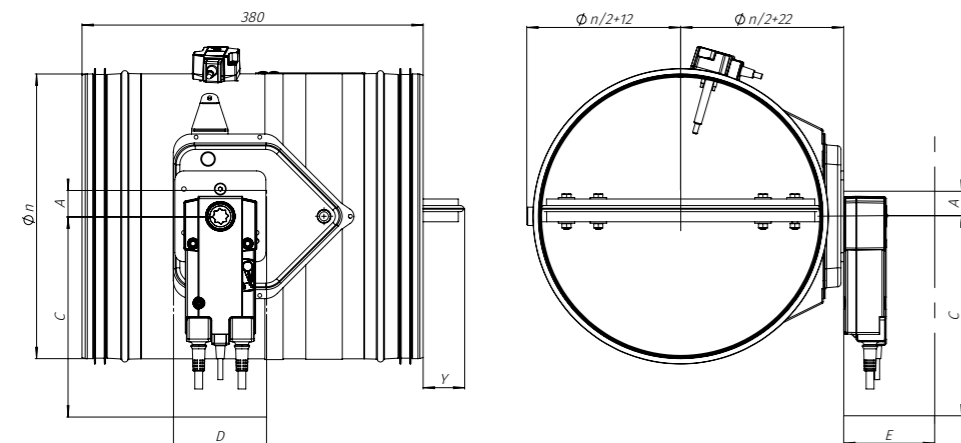

Length of damper blade outside of casing (Y dimension on front side and X dimension on back side)

$X = (Dn/2) - 270$ (mm)
 $Y = (Dn/2) - 110$ (mm)

Product		A	C	D	E
Belimo	BFL (M)	25	200	90	120
	BFN (M)	25	225	100	120
	BF (M)	50	250	100	120
Klimaoprema	-R (FD25 / FDC 25)	55	150	105	150
	-R (FD 40 & FDC 40)	55	200	105	200
	-EMS/EMP (FD 25/40 & FDC 25/40)	55	200	105	200

All installation opportunities are valid for:

- Installation onto duct in any shaft axis angle position

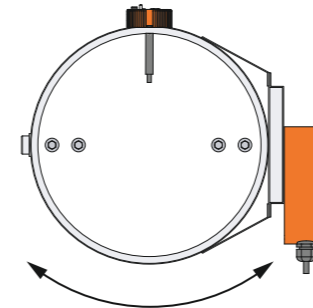

- Airflow and fire protection in both sides

INSTALLATION AND IMPLEMENTATION

INSTALLATION:

- Mounting is possible with the blade axis in horizontal or in vertical position
- The installation must comply with the tests that were performed during certification
- Avoid any obstruction of the moving blade by the connected ducts
- The class of air-tightness is maintained in case the installation of the damper is made in accordance with the technical manual
- Operating temperature: 50° C max
- For indoor use only

The FDC25 / FDC40 fire damper is always tested in standardized support frames (both in a concrete wall and in a flexible wall) in accordance with EN 1366-2: 1999 table 3/4/5. The results obtained are valid for all similar support frames which have a thickness and / or density and / or fire resistance similar or greater than the one of the test.

Examples of similar constructions:

Aerated concrete wall 100 mm + density 550 kg/m3 + fire resistance $\leq 120'$	Wall made of hollow or solid bricks, reinforced concrete, cellular concrete, light concrete, ... + Fire resistance $\geq 120'$
Cellular concrete slab 100 mm + density 550 kg/m3 + fire resistance 90'	Concrete parts, pre-stressed concrete, reinforced concrete, cellular concrete ... + fire resistance $\geq 120'$

INSTALLATIONS AND SEALING:

Concrete wall and reinforced concrete wall installation

The wall is composed of concrete blocks (minimum density of 550 kg/m³) and with a minimum thickness of 100 mm.

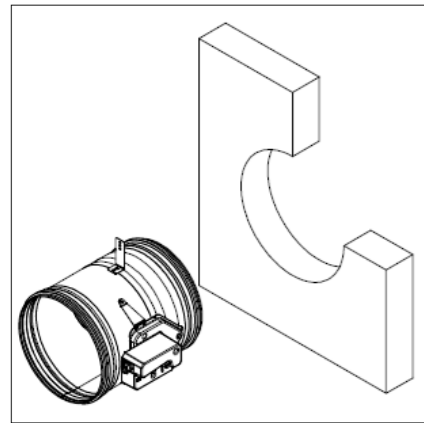

Place the damper in an opening of $\varnothing + 70$ mm or more

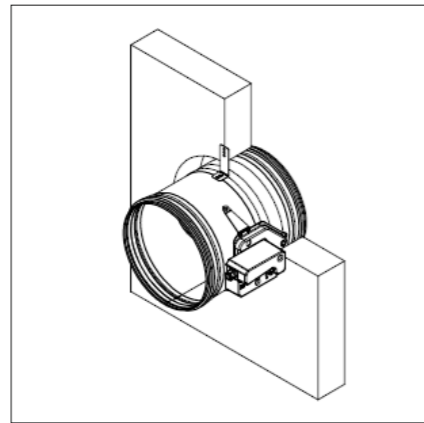

Fix the damper to the wall using screws

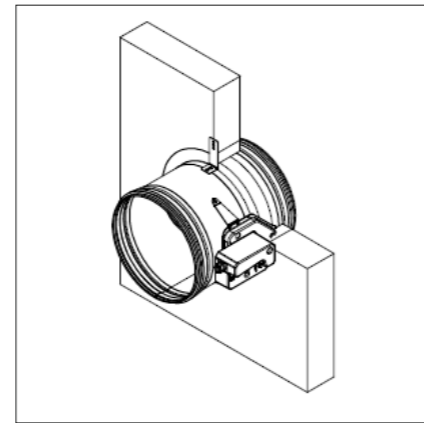

Fill the space between the damper and the wall with mortar

Aerated concrete ceiling installation and reinforced concrete ceiling installation

The ceiling is made of aerated concrete with a minimum density of 550 kg/m³ and a minimum thickness of 100 mm.

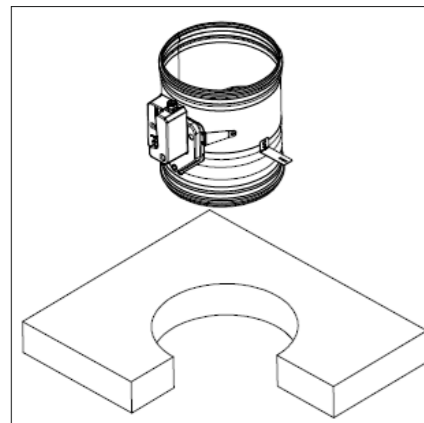

Place the damper in an opening of $\varnothing + 70$ mm or more

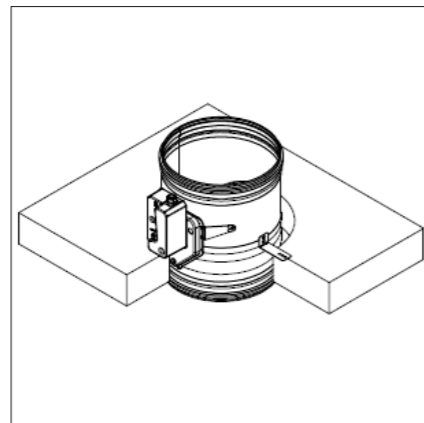

Fix the damper to the slab using screws

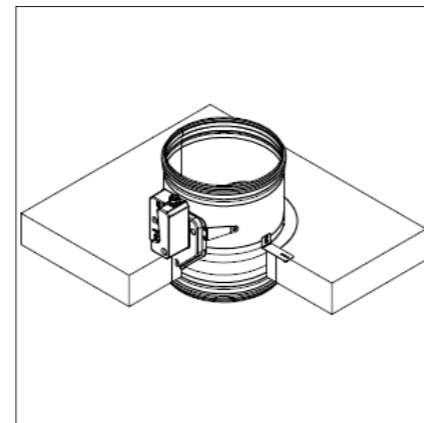

Fill the space between the damper and the slab with mortar

Gypsum blocks wall mounting 70mm

The wall is composed of gypsum blocks (minimum density of 995kg/m³), and with minimum thickness of 70mm.

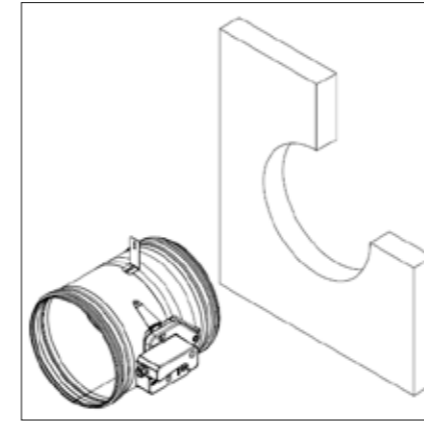

Place the damper in an opening of $\varnothing + 70$ mm or more

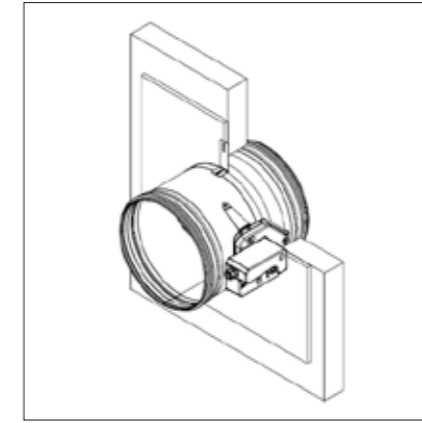

Fix damper and GKF gypsum boards (12,5mm thick) to wall with screws

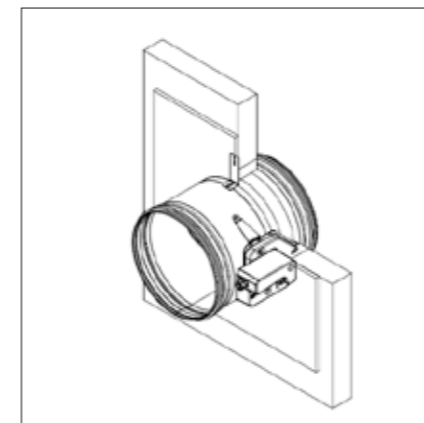

Fill the space between the damper and the wall with mortar

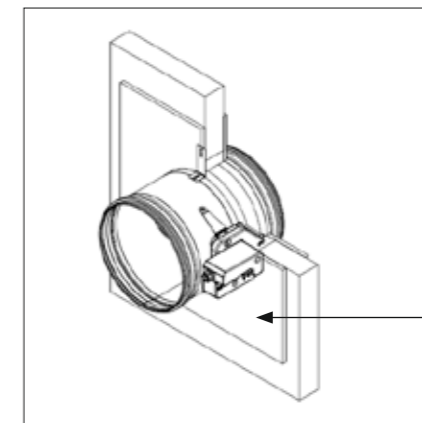

Cover the mortar with GKF gypsum boards (12,5 mm thick)

Width of the damper B (mm)	Mounting kit
100	60061429
125	60061430
160	60061431
200	60061432
250	60061433
315	60061435
355	60061436
400	60061437
450	60061438
500	60061439
560	60061440
630	60061441
710	60061442
800	60061443

* The Kit is universal for all dimensions and must be cut to fit the specific dimensions of the damper

Gypsum blocks wall mounting 100mm

The wall is composed of gypsum blocks (minimum density of 995kg/m3), and with minimum thickness of 100mm.

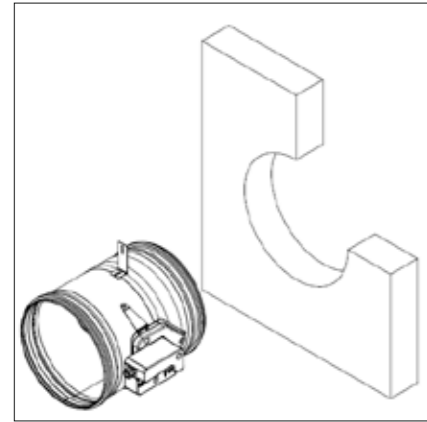

Place the damper in an opening of $\varnothing + 70$ mm or more

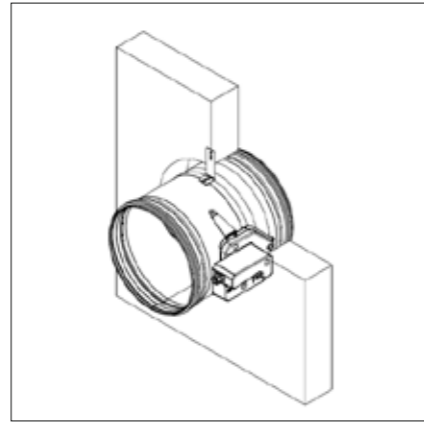

Fix the damper to the wall using screws

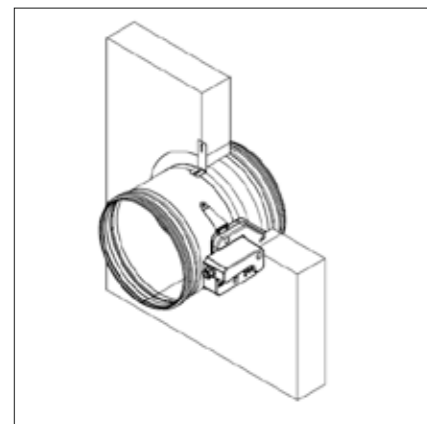

Fill the space between the damper and the wall with mortar

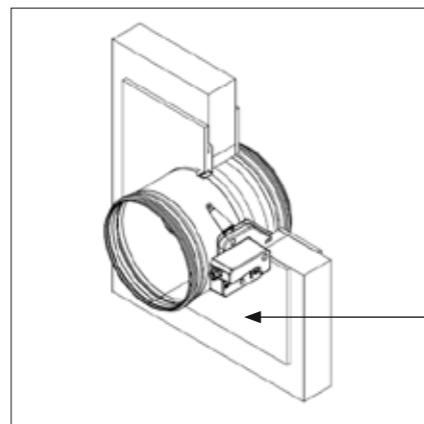

Cover the mortar with GKF gypsum boards (12,5 mm thick)

Width of the damper B (mm)	Mounting kit
100	60061429
125	60061430
160	60061431
200	60061432
250	60061433
315	60061435
355	60061436
400	60061437
450	60061438
500	60061439
560	60061440
630	60061441
710	60061442
800	60061443

* The Kit is universal for all dimensions and must be cut to fit the specific dimensions of the damper

Flexible wall mounting

The wall is composed of 2x2 GKF plates, 12,5 mm thick, installed on a 48 mm wide steel construction. The interior of the wall is filled with mineral wool of 100 kg / m3 density.

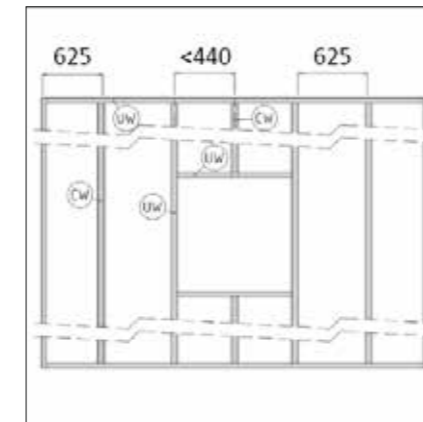

Realization of the steel construction

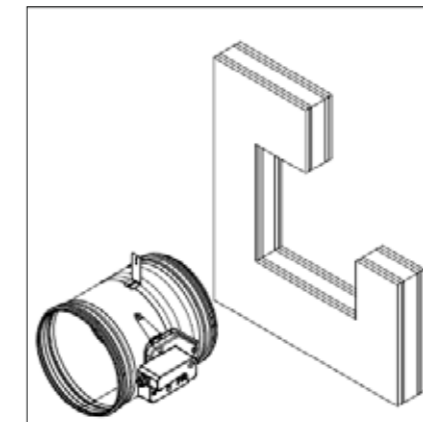

Place the damper in an opening of $\varnothing + 70$ mm or more

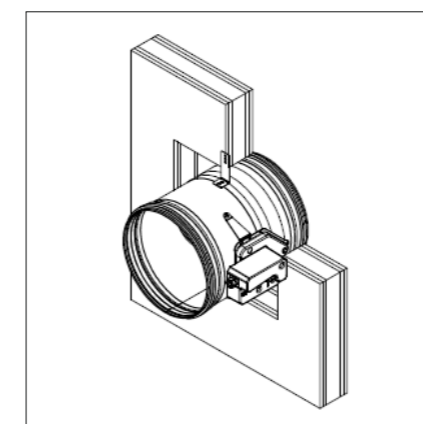

Fix the damper to the wall using screws

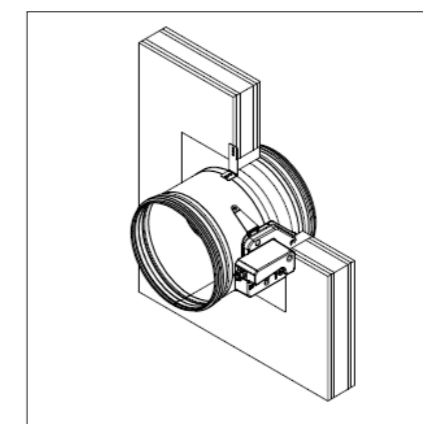

Fill the space between the damper and the wall with mineral wool (100 kg/m3 of density)

Width of the damper B (mm)	Mounting kit
100	60061429
125	60061430
160	60061431
200	60061432
250	60061433
315	60061435
355	60061436
400	60061437
450	60061438
500	60061439
560	60061440
630	60061441
710	60061442
800	60061443

* The Kit is universal for all dimensions and must be cut to fit the specific dimensions of the damper

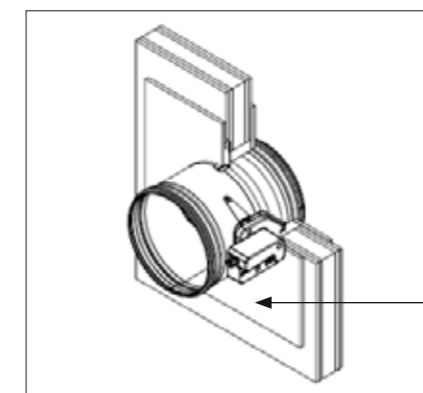

Cover the mineral wool with GKF gypsum boards (12,5 mm thick)

Flexible wall mounting

The wall is composed of 2x2 GKF plates (example PROMATECT 100, 12,5 mm thick), installed on a steel construction of 48 mm width.

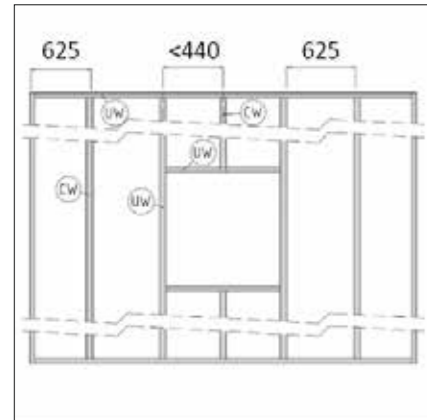

Realization of the steel construction

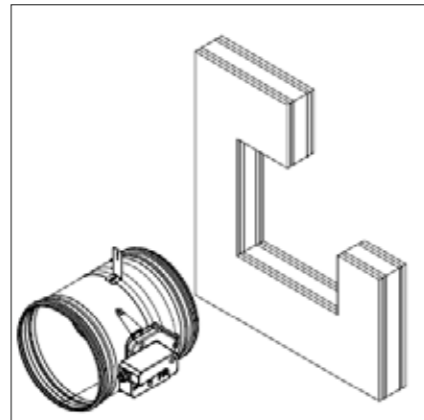

Place the damper in an opening of $\varnothing + 70$ mm or more

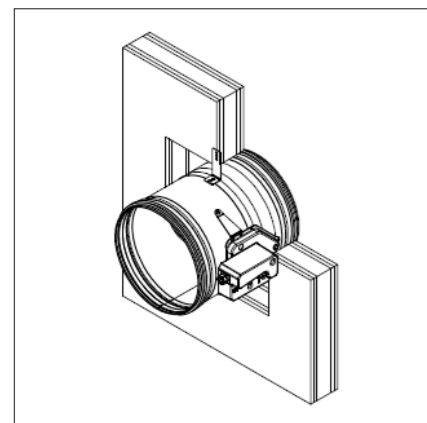

Fix the damper to the wall using screws

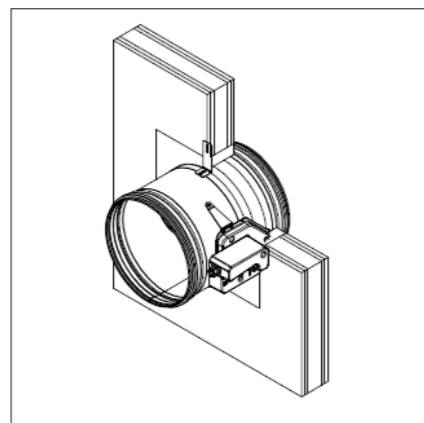

Fill the space between the damper and the wall with mortar

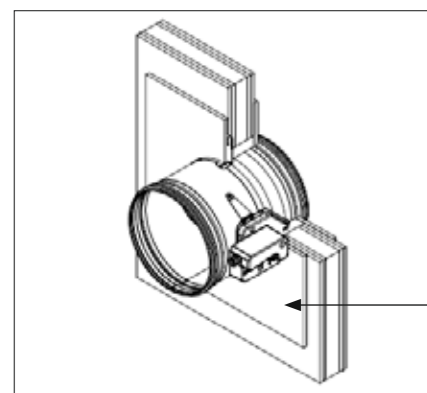

Cover the mortar with GKF gypsum boards (12,5 mm thick)

Width of the damper B (mm)	Mounting kit
100	60061429
125	60061430
160	60061431
200	60061432
250	60061433
315	60061435
355	60061436
400	60061437
450	60061438
500	60061439
560	60061440
630	60061441
710	60061442
800	60061443

* The Kit is universal for all dimensions and must be cut to fit the specific dimensions of the damper

Installation remote from flexible/rigid wall

The wall is composed of 2x2 GKF plates, 12,5 mm thick, installed on a 48 mm wide steel construction. The interior of the wall is filled with mineral wool of 100 kg / m³ density.

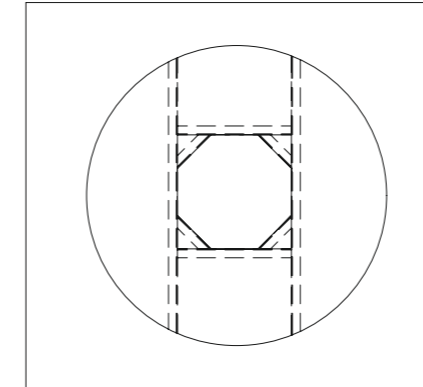

Arrangement of steel profiles.

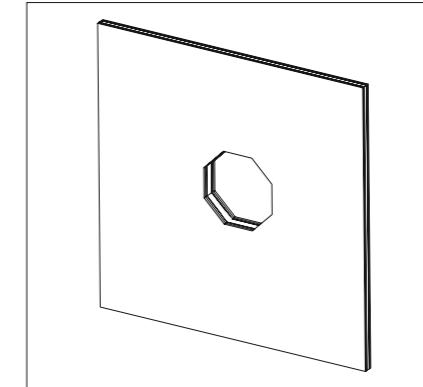

Recommended wall opening is $\varnothing n + 70$ mm (wall cover with gypsum plates)

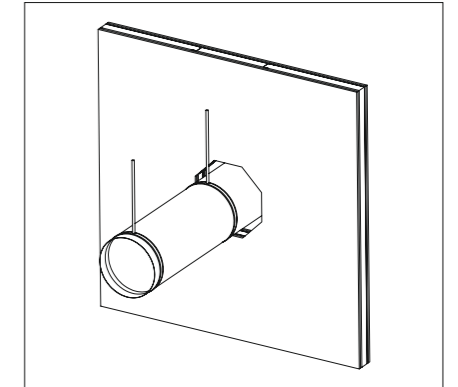

Place ventilation duct through wall

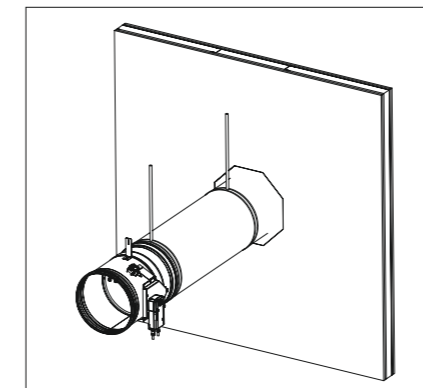

Install fire damper and secure it with self-tapping screws 4,3x10 to duct

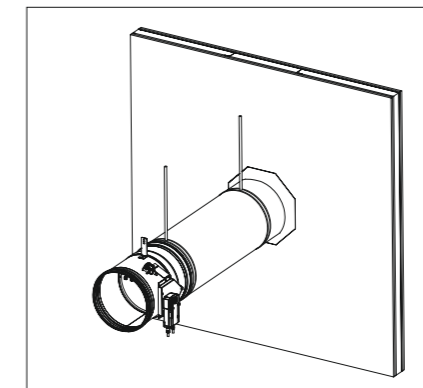

Fill space between duct and wall with mineral wool (Isover U protect). Additionally paint wool with Isover BSF in thickness of 1mm

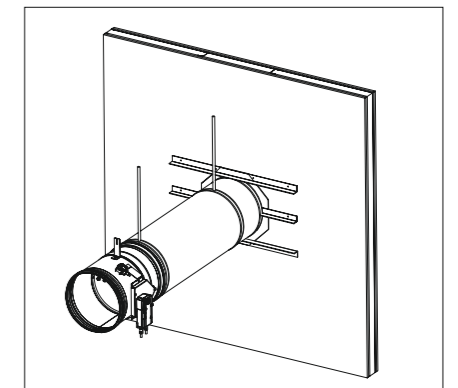

Close installation with L profiles 30x30x3mm. Additionally fix profiles to duct with self-tapping screws, and screw them to wall with 4,5x50 screws.

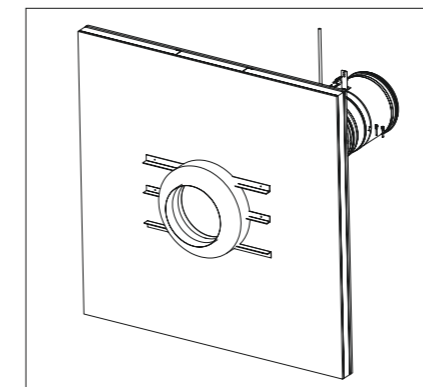

Repeat the same procedure on the other side. Place the wool on ventilation duct in length of 80m.

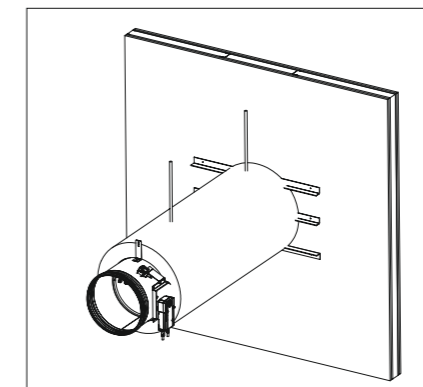

On connection wool-wall apply glue Isover BSK in thickness of 2mm.

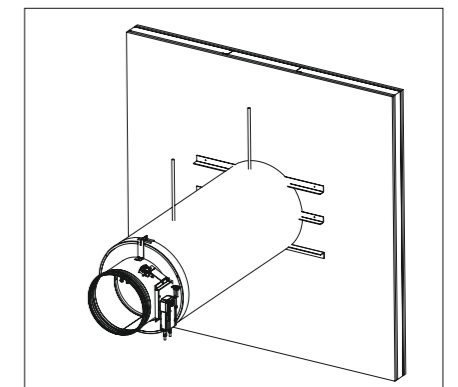

Additionally place steel protection on place where insulation on damper ends.

Installation in ceiling (Weichschott)

Installation material: Fire damper FDC, Mineral wool >140kg/m3, Fire protection coating, (HILTI weichschott system)

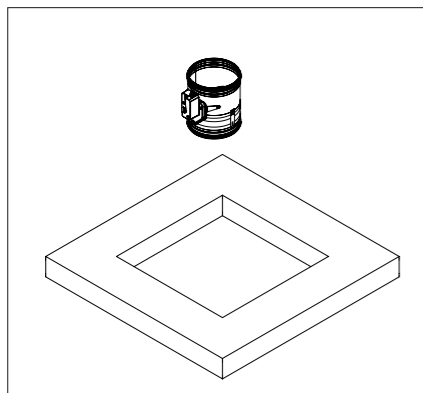

Recommended ceiling opening for fire damper installation is Ø + 400mm, but openings from Ø + 80...600 mm can also be used

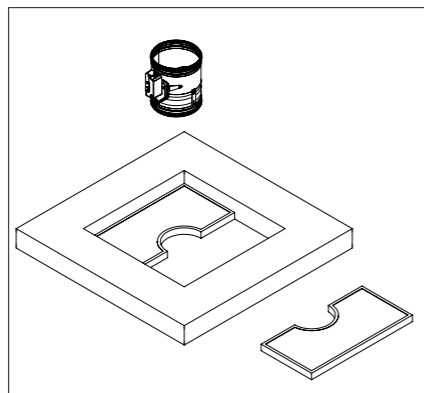

Insert fire damper into ceiling
Damper blade must be closed during installation!

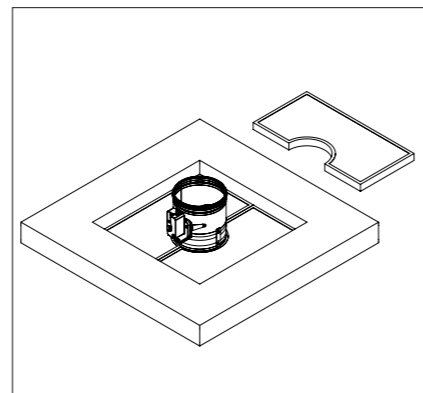

Space between casing and ceiling close with three layers of mineral wool (density 140 kg/m3 or more, coated on one side)

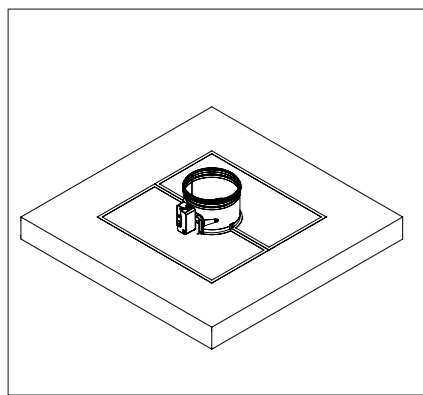

Connections of mineral wool should be sealed with intumescent fire resistant sealant. Mineral wool and damper casing must be coated with 2 mm thick fire protection coating

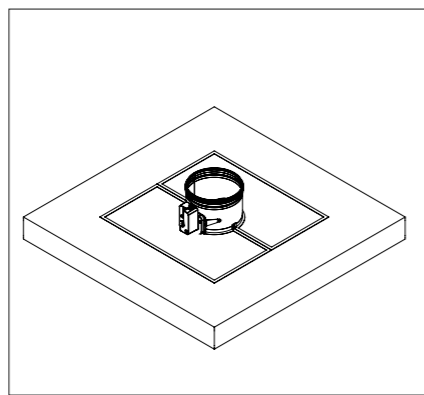

Cut additional 50 mm thick rings to cover fire damper perimeter from both sides

Installation in flexible wall (Weichschott)

Installation material: Fire damper FDC, Mineral wool >140kg/m3, Fire protection coating, (HILTI weichschott system)

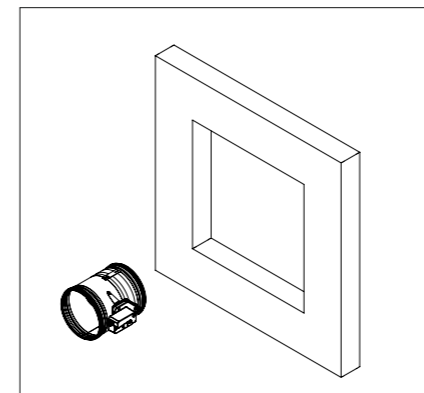

Recommended wall opening for fire damper installation is Ø + 400mm, but openings from Ø + 80...600 mm can also be used

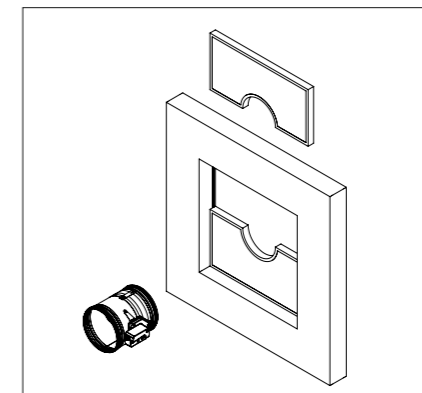

Insert fire damper into wall
Damper blade must be closed during installation!

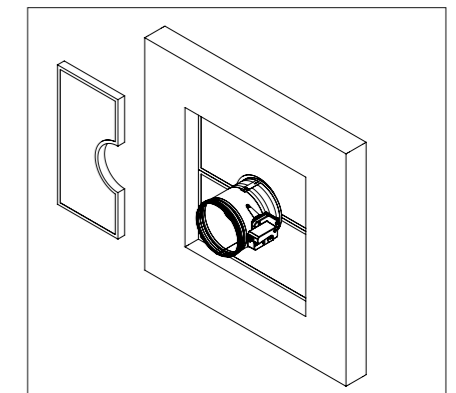

Space between casing and wall close with three layers of mineral wool (density 140 kg/m3 or more, coated on one side)

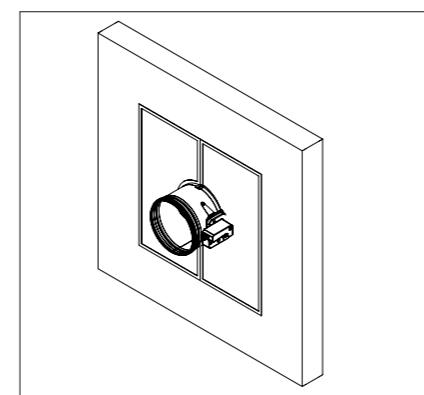

Connections of mineral wool seal with intumescent fire resistant sealant. Mineral wool and damper casing must be coated with 2 mm thick fire protection coating

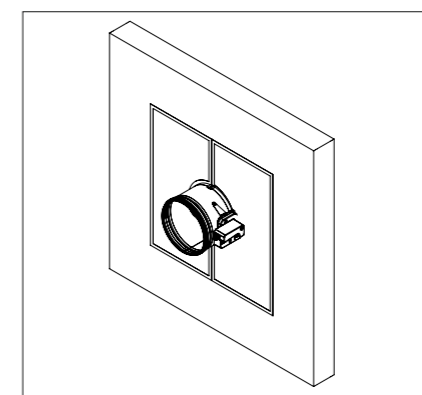

Cut additional 50 mm thick rings to cover fire damper perimeter from both sides

Suspension for mortarless installation

Suspension systems are required for the dry mortarless installation of the fire damper with mineral wool in solid walls, flexible walls and ceiling slabs. Fire dampers can be suspended from solid ceiling slabs using adequately sized threaded rods. Load the suspension system only with the weight of the fire damper. Ducts must be suspended separately. Suspension systems longer than 1.5 m require fire-resistant insulation.

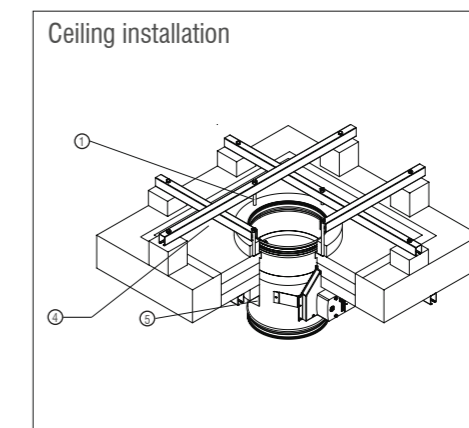
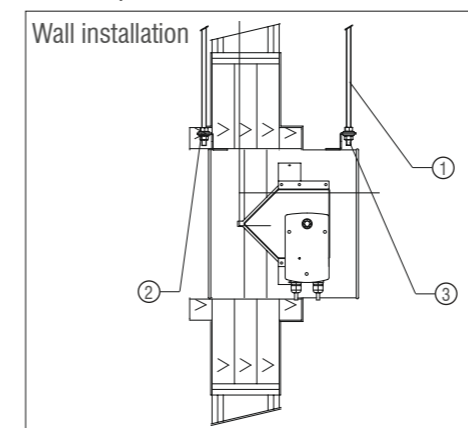

- ① Threaded rod (M10), galvanized steel
- ② Washer, galvanized steel
- ③ Nut, galvanized steel
- ④ Bracket, 45x30x1,5 mm, galvanized steel
- ⑤ L shaped profile (50x50x1) secured with self tapping screw to damper housing



FIRE DAMPER FD25/FD40



- Used for the isolation of duct penetrations between fire compartments.
- Fire dampers consist of housing, fire-resistant damper blade and release mechanism.
- Casing made of galvanized sheet steel, damper blade made of special insulating material, damper blade shaft and push rod made of stainless steel, bearings made of brass, seals made of polyurethane and elastomer.
- Closed blade air leakage according to EN 1751, class 2
- Casing air leakage to EN 1751, class C
- Fire damper can be equipped with thermic fuse with 72°C or for warm air ventilation systems 95°C release temperature
- Fire damper casing is manufactured from galvanized steel, but on demand can be made from:

- Galvanized steel and powder coated
- Stainless steel
- Stainless steel and powder coated
- Fire damper for areas with potentially explosive atmospheres
- are also available (for additional information see FD-Ex catalog)

Dimensions

FD25 dimensions B(W) x H [mm]	FD40 dimensions B(W) x H [mm]
100x200 - 800x600	800x600 - 1500x800

*All possible combinations of width and height are available.

**Standard dimensions are available with increments of 50mm.

FIRE CLASSIFICATION (according to EN 13501-3)

Fire resistance of fire damper depends on classification of walls or ceilings. It is allowed to install products to walls or ceilings only according to products Declaration of Performance. Walls or ceilings with greater fire resistance can also be used. Fire damper should be installed according to installation manual which can be found within this document

Please consult latest Declaration of Performance on our website: www.klimaoprema.hr

SELECTION DIAGRAM

Symbol:

- v - air velocity in the duct [m/s]
- Δp_t - total pressure loss [Pa]
- L_{WA} - sound power level [dB(A)]

Total pressure loss and sound power level:

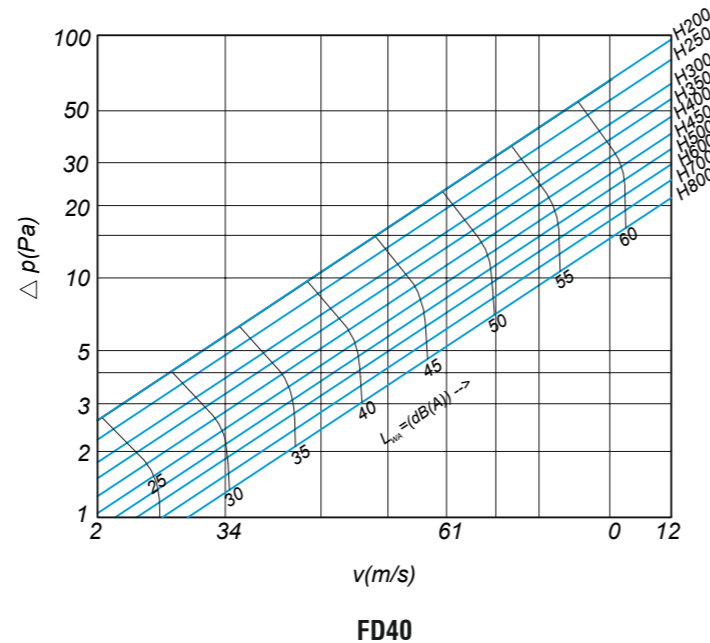
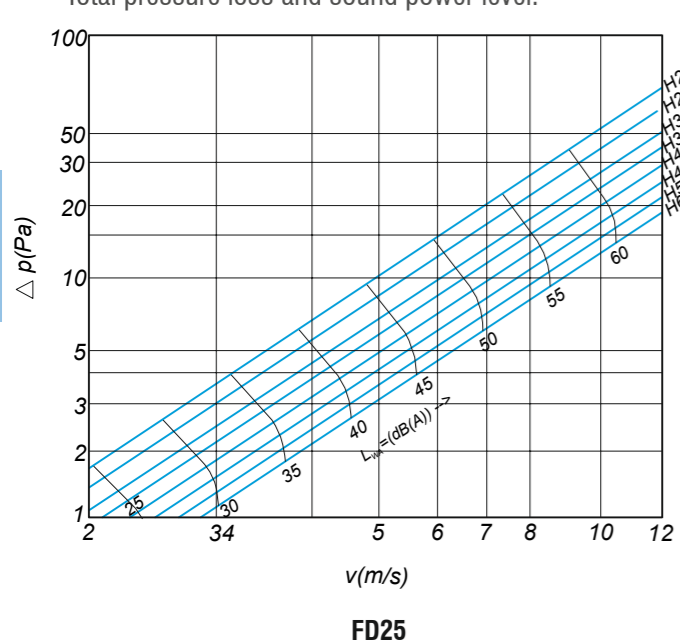

The values of total pressure loss for other sizes are obtained in a manner that read value from the graph is multiplied with the correction value from the table. Value of sound power are obtained in a manner that read value is added the correction value from the table.

B [mm]	100	200	250	300	350	400	450	500	550	600	650	700	750	800
$\Delta p_t \times$	1,30	1,22	1,14	1,07	1,0	0,94	0,88	0,83	0,77	0,73	0,68	0,64	0,6	0,58
$L_{wa} +$	-1	-1	-1	0	0	0	0	0	0	0	0	1	1	2

ORDERING KEY

Damper type: FD25 - 400x300 - M230-S
FD40

Damper dimensions
B(W) x H [mm]

Mechanism type:

- R** - manual drive
- R-S** - manual drive with limit switches
- M230-S** - electric actuator AC230V
- M24-S** - electric actuator AC/DC 24V
- M24-S-ST** - electric actuator AC/DC 24V with connection plug
- EMS-S** - electromagnetic drive, permanent
- EMP-S** - electromagnetic drive, interruptive

DAMPER MODELS

FD25 / FD40 -R (manual actuator)

- automatic closure when the temperature in the duct exceeds 72°C
- manual rearmation with handle
- manual unlocking possible for periodical test of fire damper

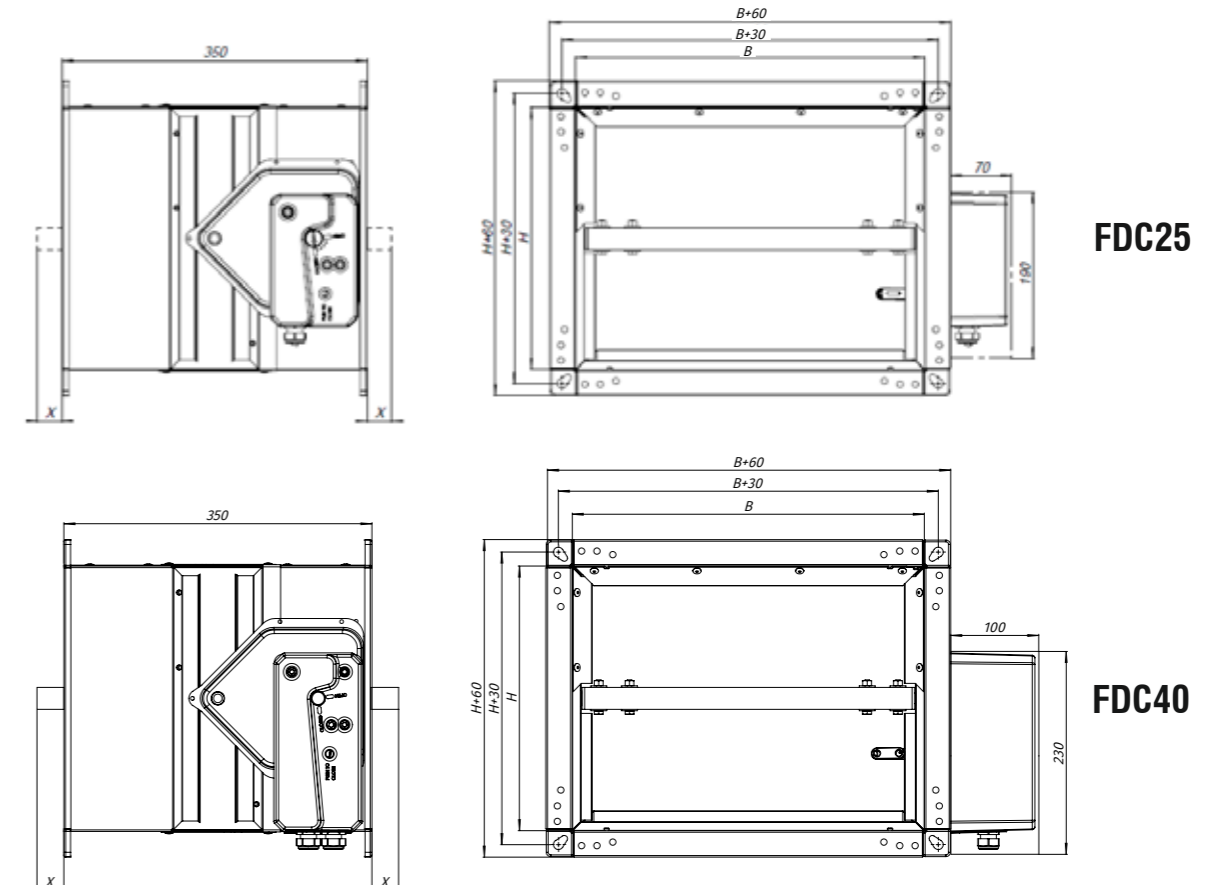

FD25 / FD40 -EMS/EMP (solenoid actuator)

- spring return actuator with integrated limit switches and thermoelectric release mechanism (72°C)
- manual rearmation with handle
- possible closing with solenoid
- manual closing possible

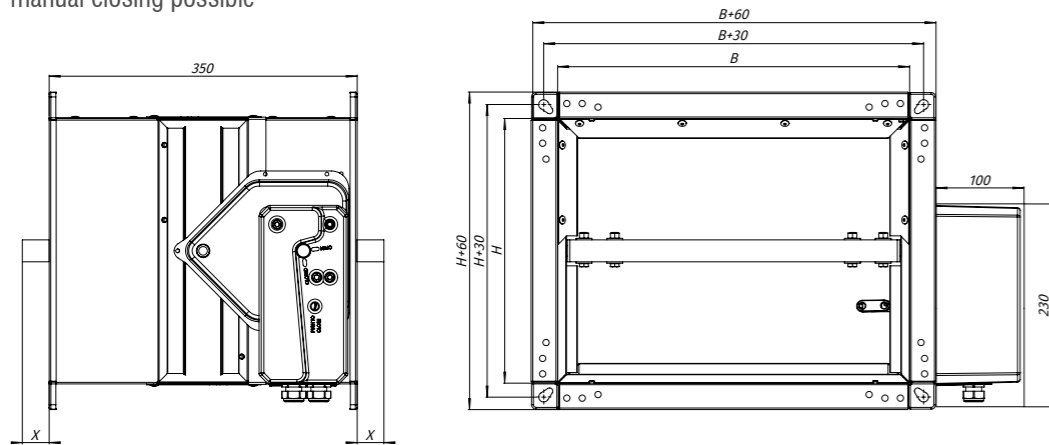

FD25 / FD40 -M (electric actuator)

- Thermoelectric activation (72°C) with electric actuator and return spring
- Integrated end switches
- Fully automatic operation

Options:

- M230 – electric actuator AC 230V
- M24 – electric actuator AC/DC 24V

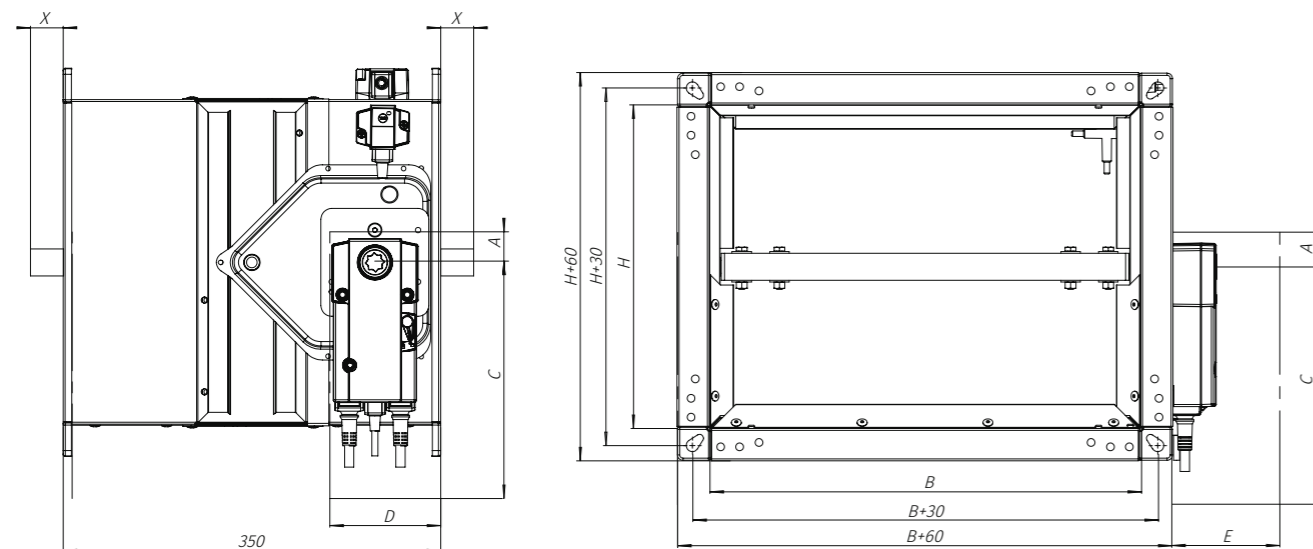

Length of damper blade outside of casing:

$X = (Dn/2) - 270$ (mm)

Product		A	C	D	E
Belimo	BFL (M)	25	200	90	120
	BFN (M)	25	225	100	120
	BF (M)	50	250	100	120
Klimaoprema	-R (FD25 / FDC 25)	55	150	105	150
	-R (FD 40 & FDC 40)	55	200	105	200
	-EMS/EMP (FD 25/40 & FDC 25/40)	55	200	105	200

All installation opportunities are valid for:

Installation onto duct in positions mentioned on picture below:

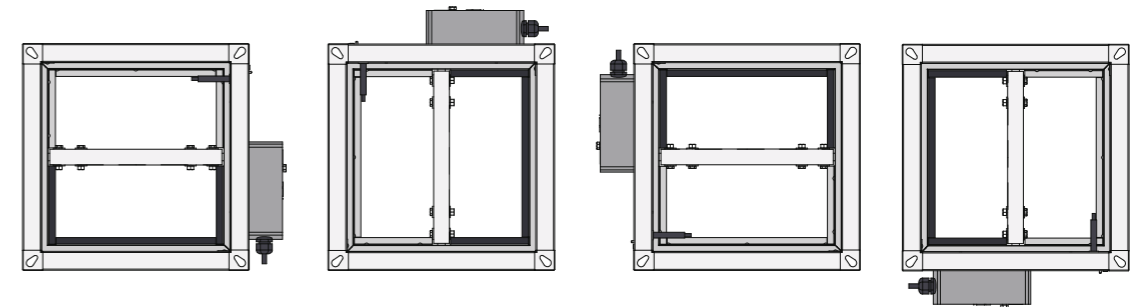

- Airflow and fire protection in both sides

INSTALLATION AND IMPLEMENTATION

- Mounting is possible with the blade axis in horizontal or in vertical position
- The installation must comply with the tests that were performed during certification, s explained in 8.2.
- Avoid any obstruction of the moving blade by the connected ducts
- The class of air-tightness is maintained in case the installation of the damper is made in accordance with the technical manual
- Operating temperature: 50° C max
- For indoor use only

The FD25 / FD40 fire damper is always tested in standardized support frames (both in a concrete wall and in a flexible wall) in accordance with EN 1366-2: 1999 table 3/4/5. The results obtained are valid for all similar support frames which have a thickness and / or density and / or fire resistance similar or greater than the one of the test.

Examples of similar constructions:

Aerated concrete wall 100 mm + density 550 kg/m3 + fire resistance $\leq 120'$	Wall made of hollow or solid bricks, reinforced concrete, cellular concrete, light concrete, ... + Fire resistance $\geq 120'$
Cellular concrete slab 100 mm + density 550 kg/m3 + fire resistance 90'	Concrete parts, pre-stressed concrete, reinforced concrete, cellular concrete ... + fire resistance $\geq 120'$

INSTALLATIONS AND SEALING:

Gypsum blocks wall mounting 70mm

The wall is composed of gypsum blocks (minimum density of 995kg/m³), and with minimum thickness of 70mm.

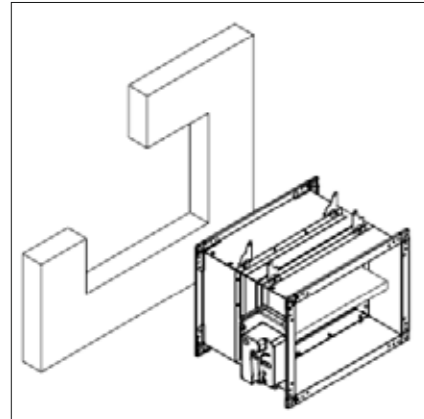

Place the damper in an opening of H + 80 mm and B + 80 mm or more

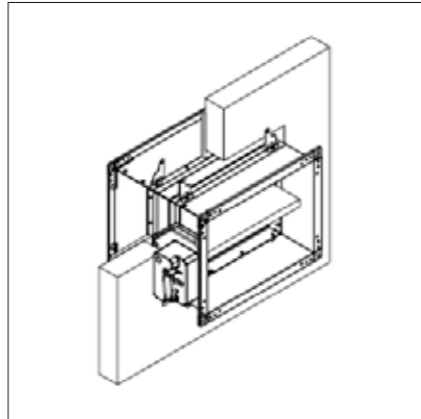

Fix damper and GKF gypsum boards (12,5mm thick) to wall with screws

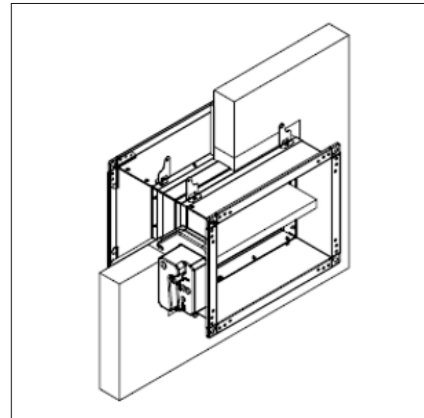

Fill the space between the damper and the wall with mortar

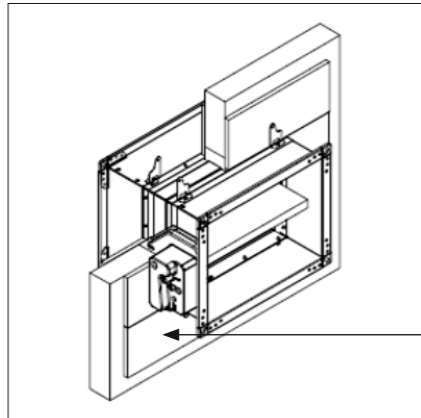

Cover the mortar with GKF gypsum boards (12,5 mm thick)

Dimensions (mm)	Mounting kit
All dimensions *	60061444

* The Kit is universal for all dimensions and must be cut to fit the specific dimensions of the damper

Gypsum blocks wall mounting 100mm

The wall is composed of gypsum blocks (minimum density of 995kg/m³), and with minimum thickness of 100mm.

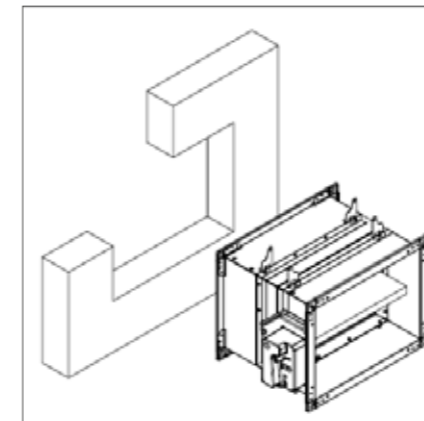

Place the damper in an opening of H + 80 mm and B + 80 mm or more

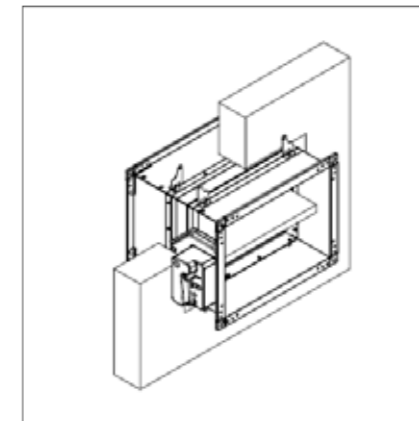

Fix the damper to the wall using screws

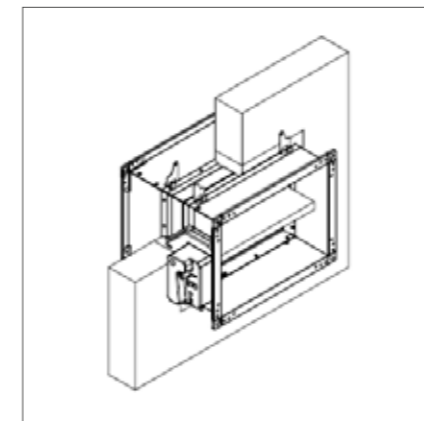

Fill the space between the damper and the wall with mortar

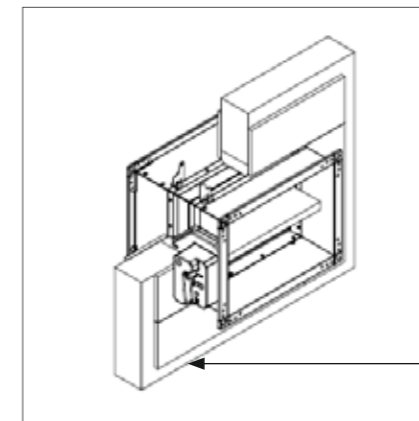

Cover the mortar with GKF gypsum boards (12,5 mm thick)

Dimensions (mm)	Mounting kit
All dimensions *	60061444

* The Kit is universal for all dimensions and must be cut to fit the specific dimensions of the damper

Concrete wall and reinforced concrete wall installation

The wall is composed of concrete blocks (minimum density of 550 kg/m³) and with a minimum thickness of 100 mm.

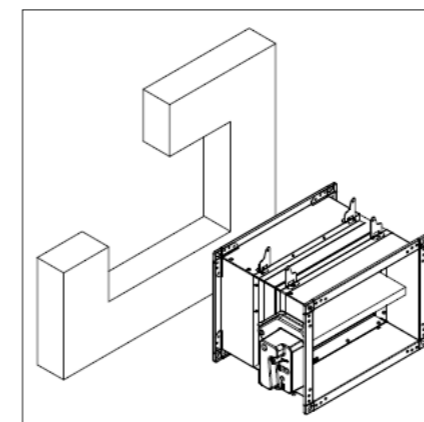

Place the damper in an opening of H + 80 mm and B + 80 mm or more

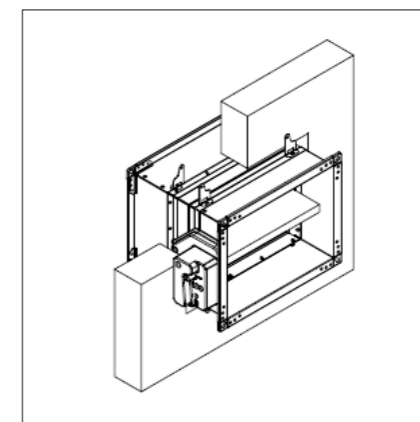

Fix the damper to the wall using screws

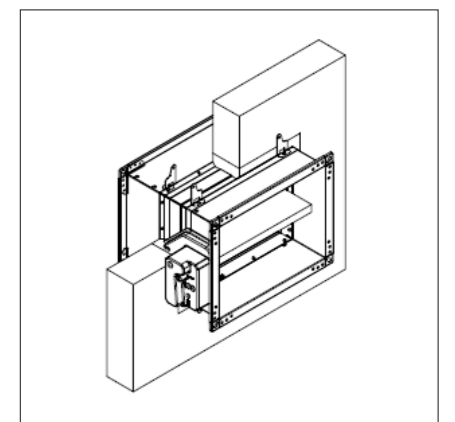

Fill the space between the damper and the wall with mortar

Installation remote from flexible/rigid wall

The wall is composed of 2x2 GKF plates, 12.5 mm thick, installed on a 48 mm wide steel construction. The interior of the wall is filled with mineral wool of 100 kg / m3 density.

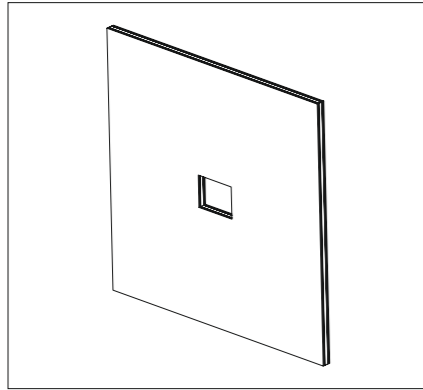

Recommended wall opening is B,H+70 mm

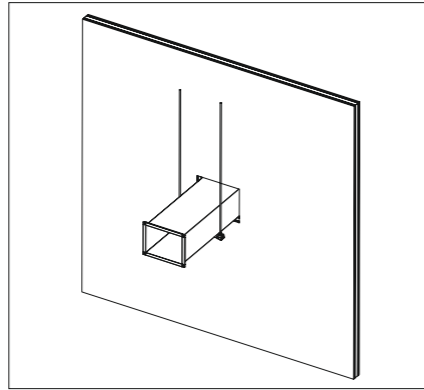

Place ventilation duct trough wall

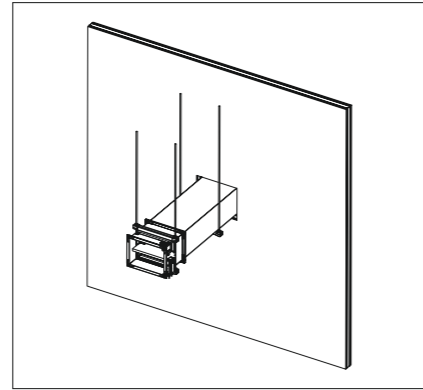

Install fire damper and secure it to ventilation duct

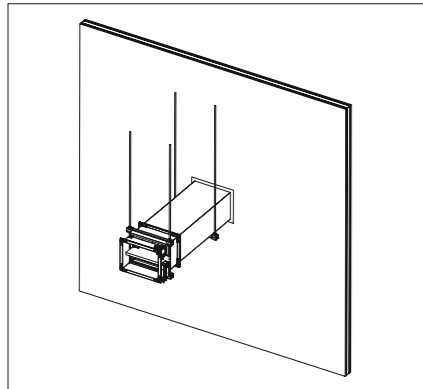

Fill space between duct and wall with mineral wool (Isover U protect). Additionally paint wool with Isover BSF in thickness of 1mm.

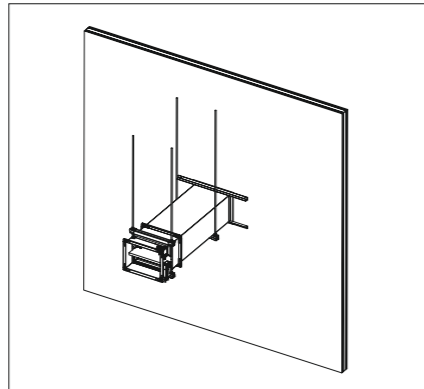

Close installation with L profiles 30x30x3mm. Additionally fix profiles to duct with self-tapping screws, and screw them to wall with 4,5x50 screws. Repeat the same procedure on the other side.

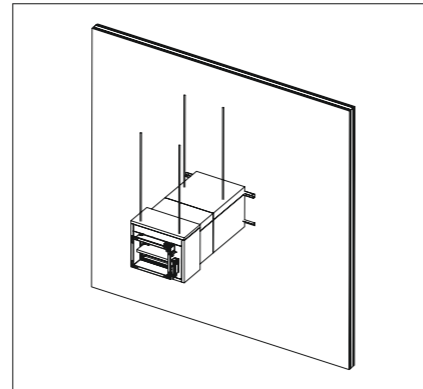

Install wool (Isover U protect). Wool should be glued to the wall with Isover BSK glue. Glue is applied in thickness 2mm. For details please see Isover U-protect brochure page 28.

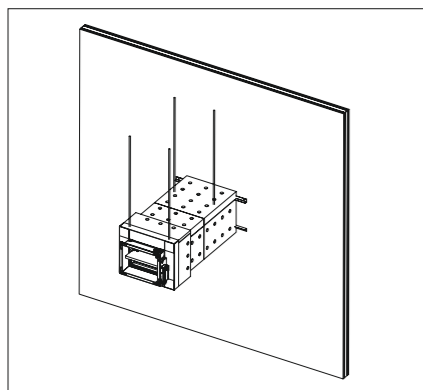

Secure the wool with welding nails. Nails are placed 60mm from the end of the plate and 150mm between each other. In the corner are additionally used IsoveFireProtectScrew screws on every 150mm. Additionally place steel protection on place where insulation on damper ends.

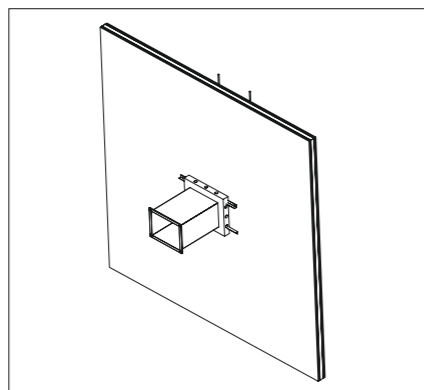

Place the wool on ventilation duct in length of 80m and secure it withwelding nails.

Flexible wall mounting

The wall is composed of 2x2 GKF plates, 12.5 mm thick, installed on a 48 mm wide steel construction. The interior of the wall is filled with mineral wool of 100 kg / m3 density.

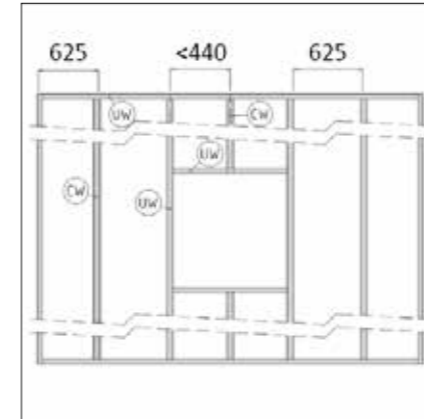

Realization of the steel construction

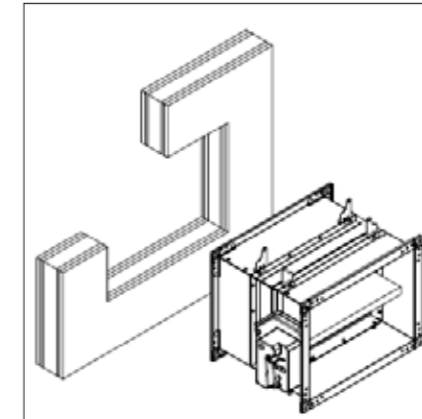

Place the damper in an opening of H + 80 mm and B + 80 mm or more

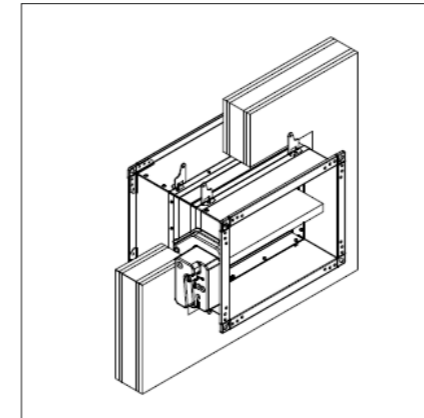

Fix the damper to the wall using screws

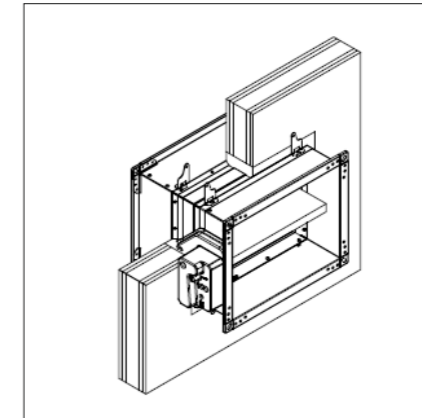

Fill the space between the damper and the wall with mineral wool

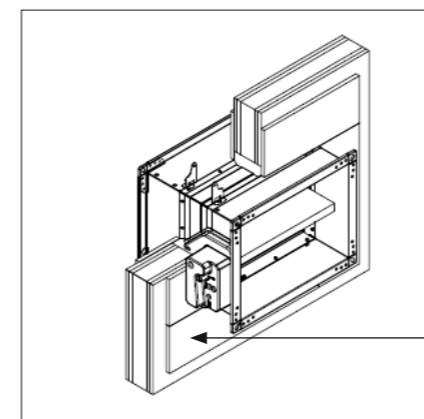

Cover the mineral wool with GKF gypsum boards (12,5 mm thick)

Dimensions (mm)	Mounting kit
All dimensions *	60061444

* The Kit is universal for all dimensions and must be cut to fit the specific dimensions of the damper

Flexible wall mounting

The wall is composed of 2x2 GKF plates (example PROMATECT 100, 12,5 mm thick), installed on a steel construction of 48 mm width.

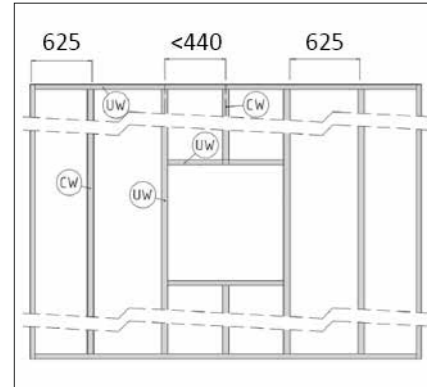

Realization of the steel construction

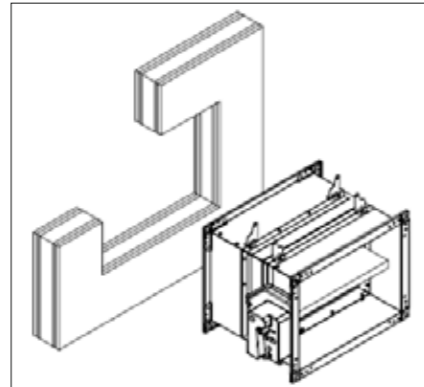

Place the damper in an opening of H + 80 mm and B + 80 mm or more

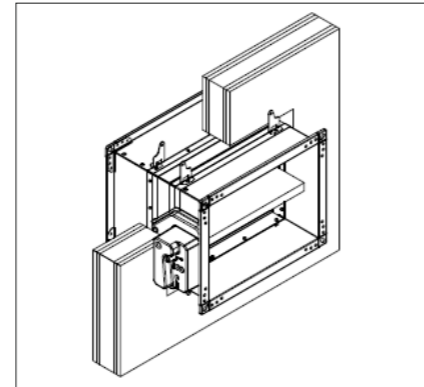

Fix the damper to the wall using screws

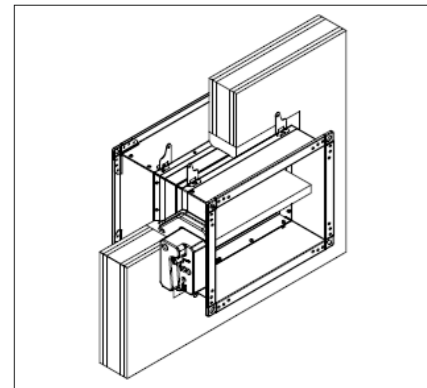

Fill the space between the damper and the wall with mortar

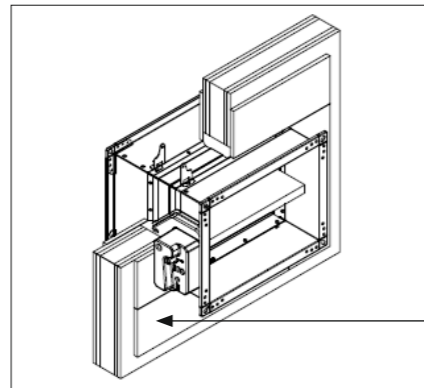

Cover the mortar with GKF gypsum boards (12,5 mm thick)

Dimensions (mm)	Mounting kit
All dimensions *	60061444

* The Kit is universal for all dimensions and must be cut to fit the specific dimensions of the damper

Battery installation

The wall is composed of blocks of aerated concrete (minimum density 550 kg/m³) and with a minimum thickness of 100 mm.

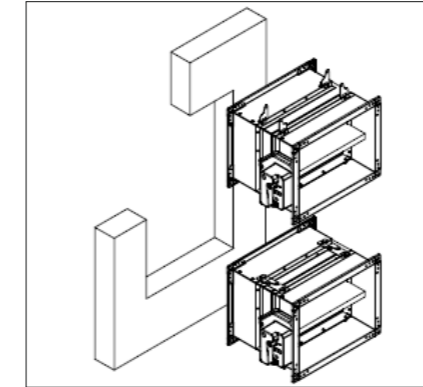

Place the damper in an opening of B + 80 mm and 2xH + 140mm

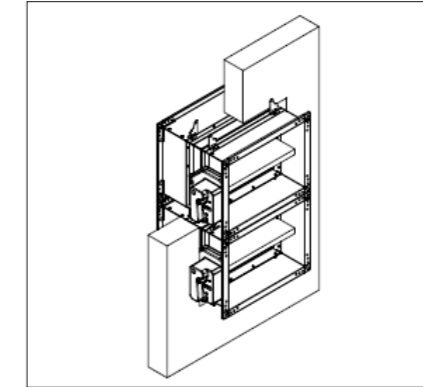

Fix the dampers to the wall using the screws and fill the space between the dampers and the wall with mortar

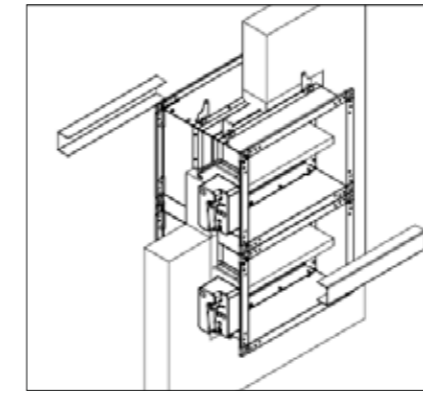

Place the installation kit to the dampers

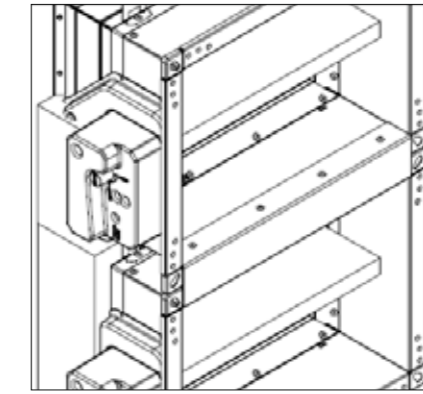

Attach the installation kit to the dampers using the self-tapping screws (provided in the kit) every 350mm

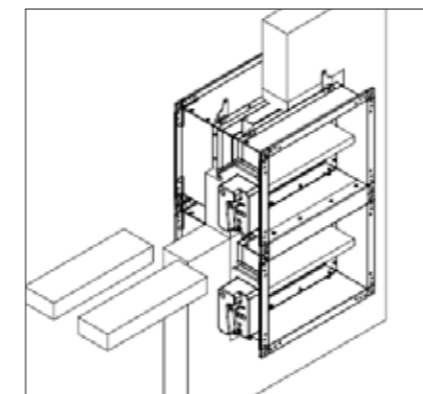

Fill the space between the dampers with mineral wool (100 kg/m³ of density)

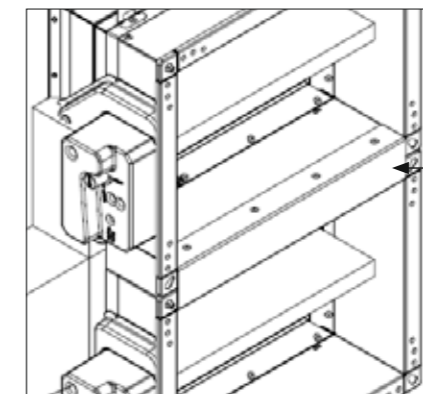

Installation completed

Width of the damper B (mm)	Mounting kit
850	60061445
900	60061446
950	60061447
1000	60061448
1050	60061449
1100	60061450
1150	60061451
1200	60061452
1250	60061453
1300	60061454
1350	60061455
1400	60061456
1450	60061457
1500	60061458

Aerated concrete ceiling installation and reinforced concrete ceiling installation

The ceiling is made of aerated concrete with a minimum density of 550 kg/m³ and a minimum thickness of 100 mm.

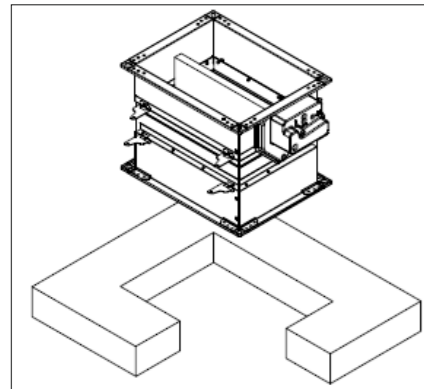

Place the damper in an opening of H + 80 mm and B + 80 mm or more

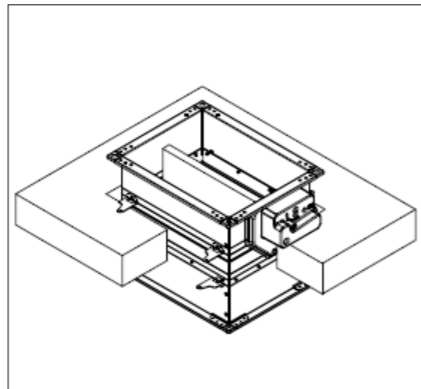

Fix the damper to the slab using screws

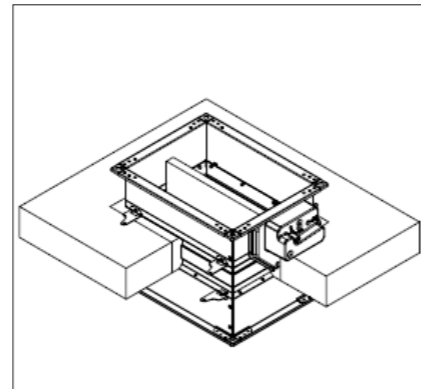

Fill the space between the damper and the slab with mortar

Installation in ceiling (Weichschott)

Installation material: Fire damper FD, Mineral wool >140kg/m³, Fire protection coating, (HILTI weichschott system)

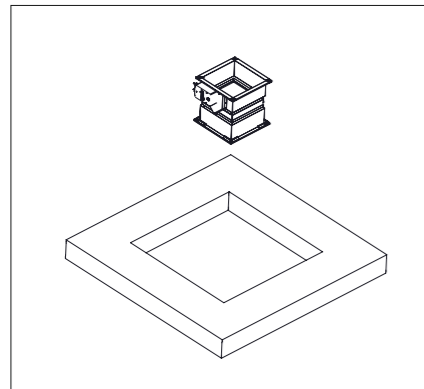

Recommended ceiling opening for fire damper installation is B(H) + 400mm, but openings from B(H) + 80...600 mm can also be used

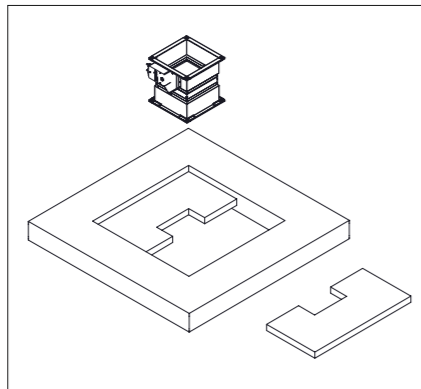

Insert fire damper into ceiling. Damper blade must be closed during installation!

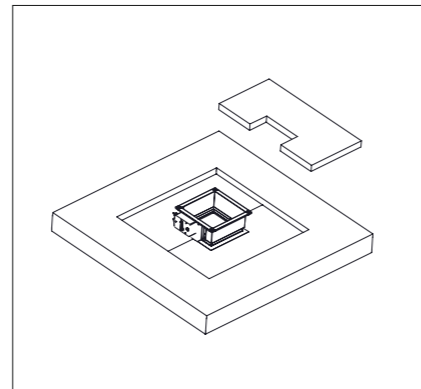

Space between casing and ceiling must be closed with three layers of mineral wool (density 140 kg/m³ or more, coated on one side)

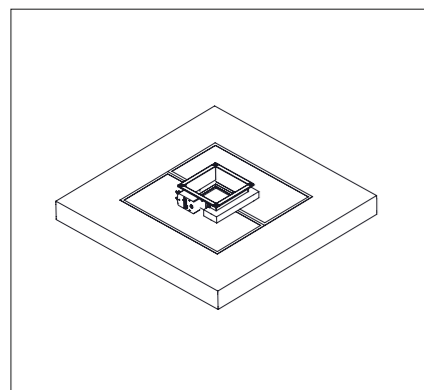

Connections of mineral wool must be sealed with intumescent fire resistant sealant. Mineral wool and damper casing must be coated with 2 mm thick fire protection coating

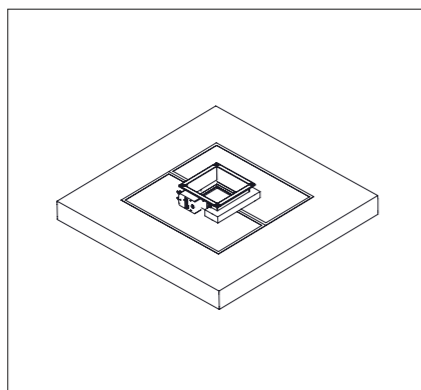

Cut additional 50 mm straps to cover perimeter of damper and ceiling

Installation in Flexible wall (Weichschott)

Installation material: Fire damper FD, Mineral wool >140kg/m³, Fire protection coating, (HILTI weichschott system)

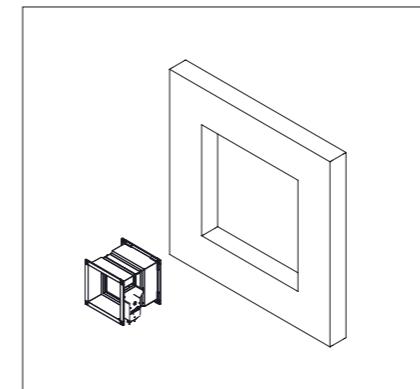

Recommended wall opening for fire damper installation is B(H) + 400mm, but openings from B(H) + 80...600 mm can also be used

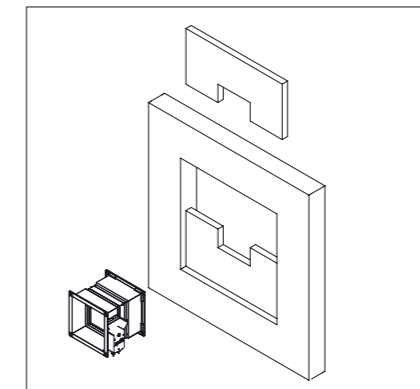

Insert fire damper into wall. Damper blade must be closed during installation!

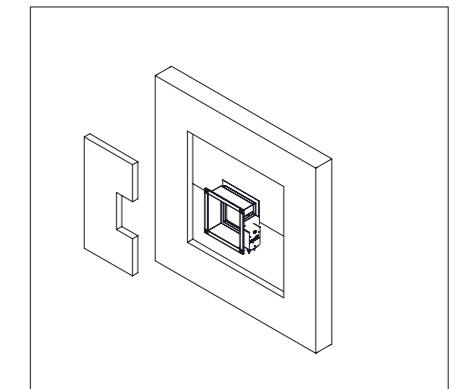

Space between casing and wall must be closed with three layers of mineral wool (density 140 kg/m³ or more, coated on one side)

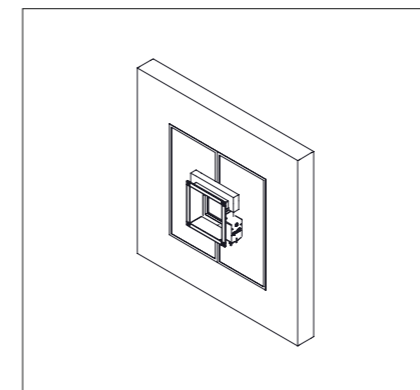

Connections of mineral wool must be sealed with intumescent fire resistant sealant. Mineral wool and damper casing must be coated with 2 mm thick fire protection coating

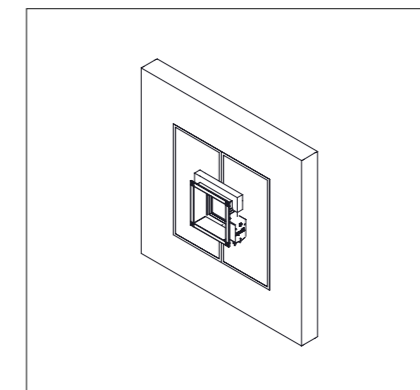

Cut additional 50 mm straps to cover perimeter of damper and wall from three sides (bottom one is not needed)

Suspension for mortarless installation

Suspension systems are required for the dry mortarless installation of the fire damper with mineral wool in solid walls, flexible walls and ceiling slabs. Fire dampers can be suspended from solid ceiling slabs using adequately sized threaded rods. Load the suspension system only with the weight of the fire damper. Ducts must be suspended separately. Suspension systems longer than 1.5 m require fire-resistant insulation.

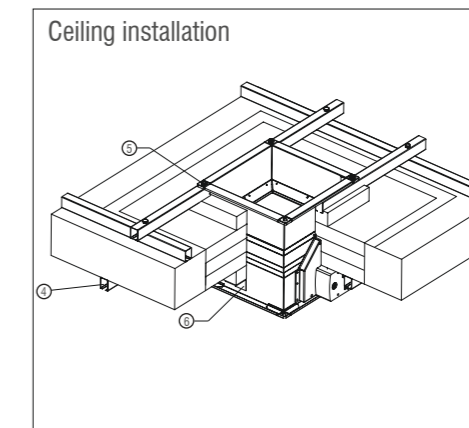
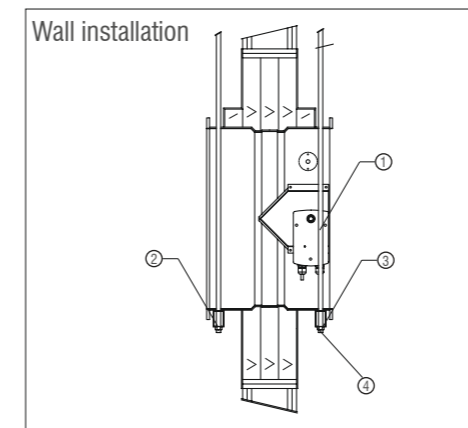

- ① Threaded rod (M10), galvanized steel
- ② Washer, galvanized steel
- ③ Nut, galvanized steel
- ④ Bracket, 45x30x1,5 mm, galvanized steel
- ⑤ Screw (M10)
- ⑥ L shaped profile (50x50x1) secured with self tapping screw to damper housing, every 400mm

Installation in rigid wall (Promat)

Prepare wall opening B (H) + 100 mm. Place fire damper on pre-cut calcium silicate 52mm (Promat L500). 100mm wide supports from same material need to be used to support the duct as well as the damper.

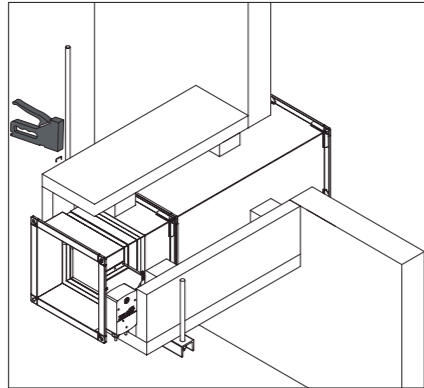
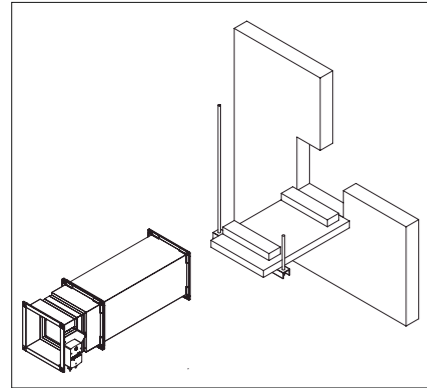

Fit the duct and the damper through the wall, and cover them with 52 mm calcium silicate (Promat L500). Board corner joints must be glued with glue PROMAT K84 and connected with staples every 100mm.

The gap between the damper and the wall must be filled with mineral wool (density 140 kg / m3 or more).

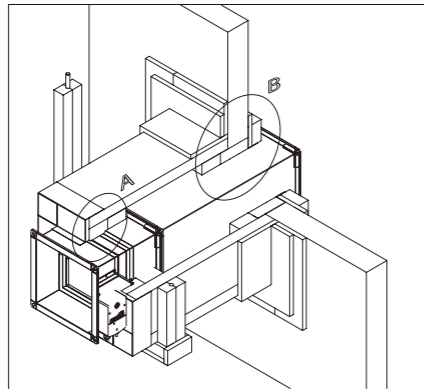
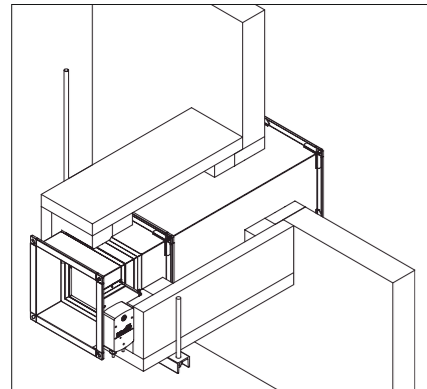

Close the mineral wool with Promat H plates 20mm thick. Duct and damper supporting brackets have to be insulated with 52 and 20mm calcium silicate boards (Promat H and L500).

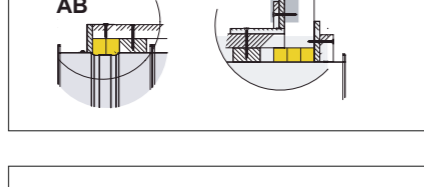

More detail drawing of installation will be send upon request!

CONTROL MECANISMS

MANUAL FUSE ONLY MECHANISM

Self-operating mechanism equipped with a thermal fuse.

The Manual fuse only control mechanism closes the damper blade automatically if the temperature in the duct exceeds 72 °C. The damper is reset manually by means of a screwdriver.

Standard equipment:

- Thermal fuse 72 °C
- Manual triggering is possible
- Manual reset, use the screwdriver (turn counterclockwise)

To open the damper, insert the screwdriver into the shaft (parallel to the ventilation duct axis) and turn counterclockwise

To close the damper, press the thermal fuse head with a screwdriver

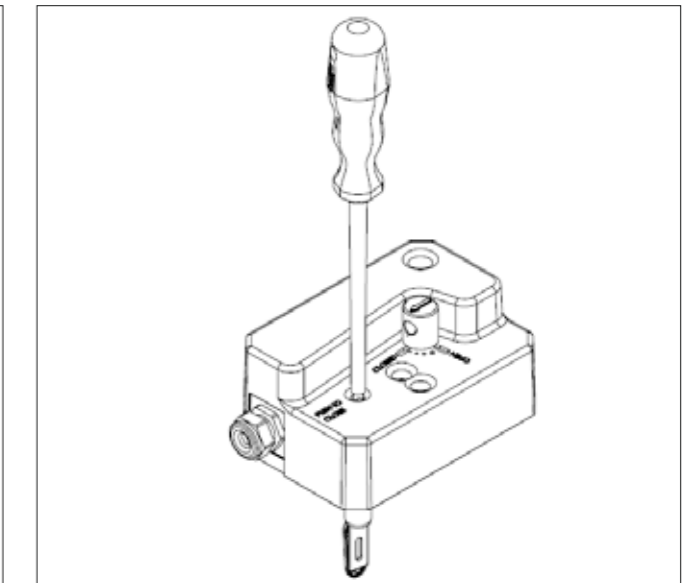
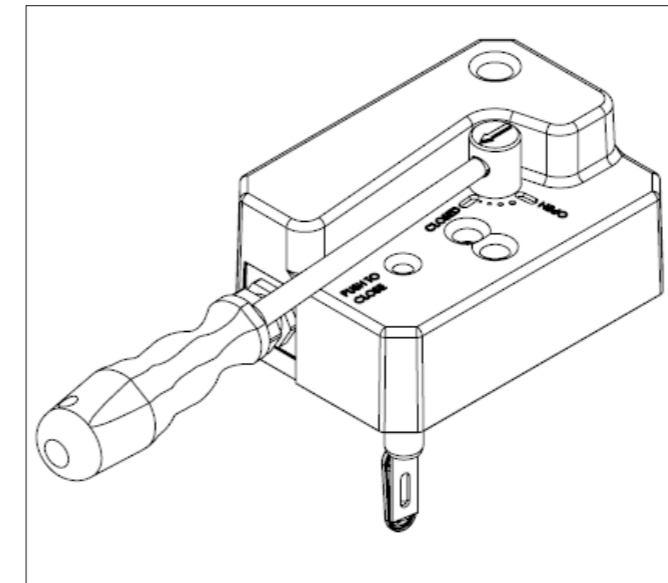

Options :

For this self-operating version, the double contact – S - is available as an option (factory option or after-sales kit):

The double contact S (OPEN / CLOSED) consists of:

- electric limit switch indicating CLOSED position
- electric limit switch indicating OPEN position

MANUAL FUSE ONLY MECHANISM UPGRADABLE TO SOLENOID ACTUATOR

FD in self-operating version

Activation :

- Manual activation: Push the release button.
- Self-operating activation: With a fuse at 72 °C

Rearming :

- Manual reset: Turn the screwdriver counter clockwise

To open the damper, insert the screwdriver into the shaft (parallel to the ventilation duct axis) and turn counterclockwise

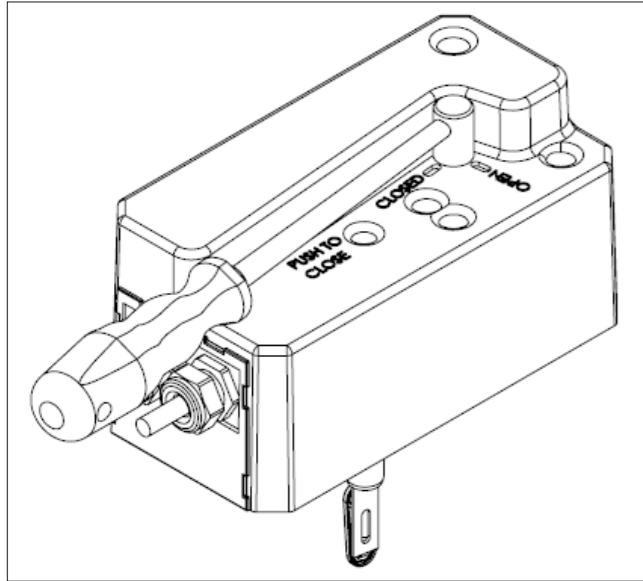

To close the damper, press the thermal fuse head with a screwdriver

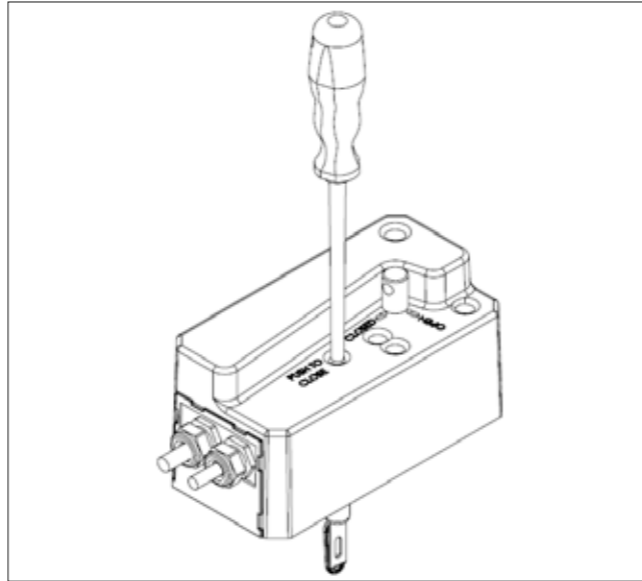

Options:

- For this self-operating version, the double contact – S and the 4-contacts – S2 - are available as an option (factory option or after-sales kit):

The 4-contact – S2 - consists of:

- electric limit switch indicating CLOSED position
- electric limit switch indicating OPEN position
- additional electric limit switch indicating CLOSED position
- additional electric limit switch indicating OPEN

Activation:

- Manual activation: Push the release button.
- Self-operating activation: With a fuse at 72 °C
- Remote activation: By emission or break of current (solenoid with 24/48 V automatic voltage selection)

Rearming:

- Manual reset: Turn the screwdriver counter clockwise

Reminder:

- For this version with remote activation, the double contact S (OPEN / CLOSED) are mounted as standard equipment
- The 4-contact – S2 - are available as an option (factory option or after-sales kit).

ELECTRICAL CONNECTIONS

MANUAL FUSE ONLY MECHANISM

- Electrical wiring of the S option
Electronic control board

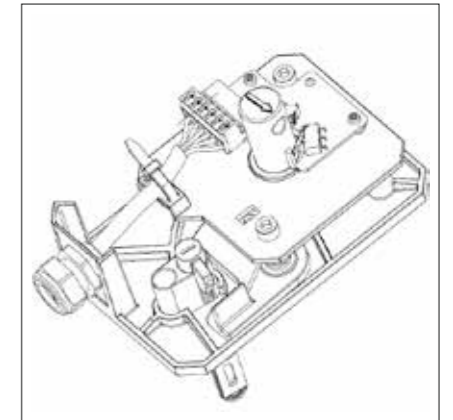
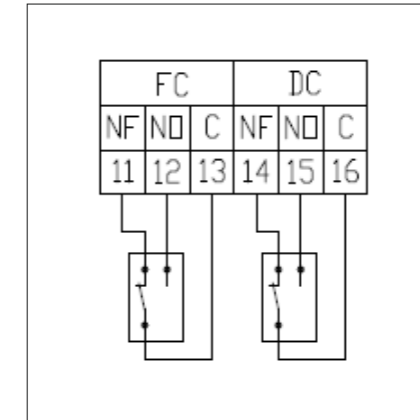
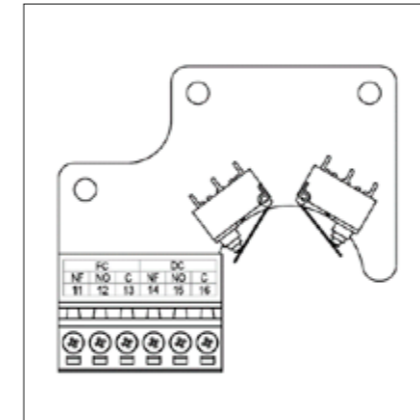

FC = Limit switch - end
DC = Limit switch - start

C = common
NO = normally open

NF = normally closed

MANUAL FUSE ONLY MECHANISM UPGRADABLE TO SOLENOID ACTUATOR

- Electrical wiring of solenoid option
Main electronic control board of coil supply

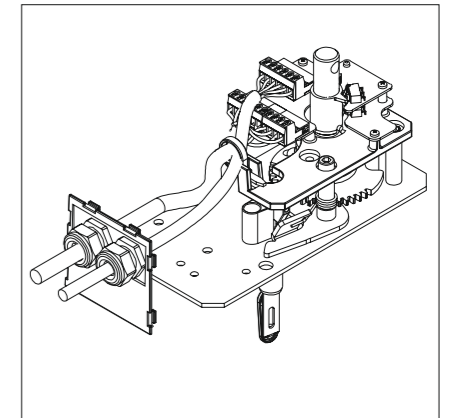
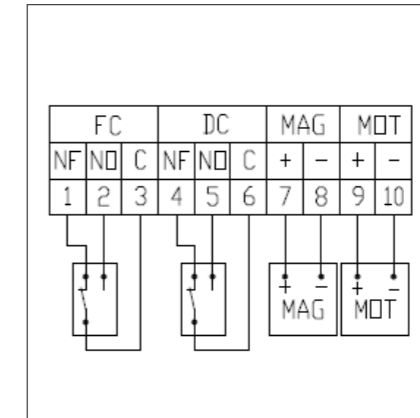
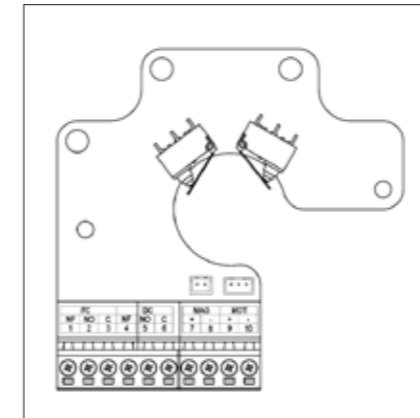

MOT = not in use MAG = solenoid power supply terminals (24 or 48 VDC)

- Electrical wiring of the S option
Main electronic control board of coil supply

FC = Limit switch - end
DC = Limit switch - start NO = normally open

NF = normally closed

- Electrical wiring of the S2 option (4 contactors).
Electronic control board

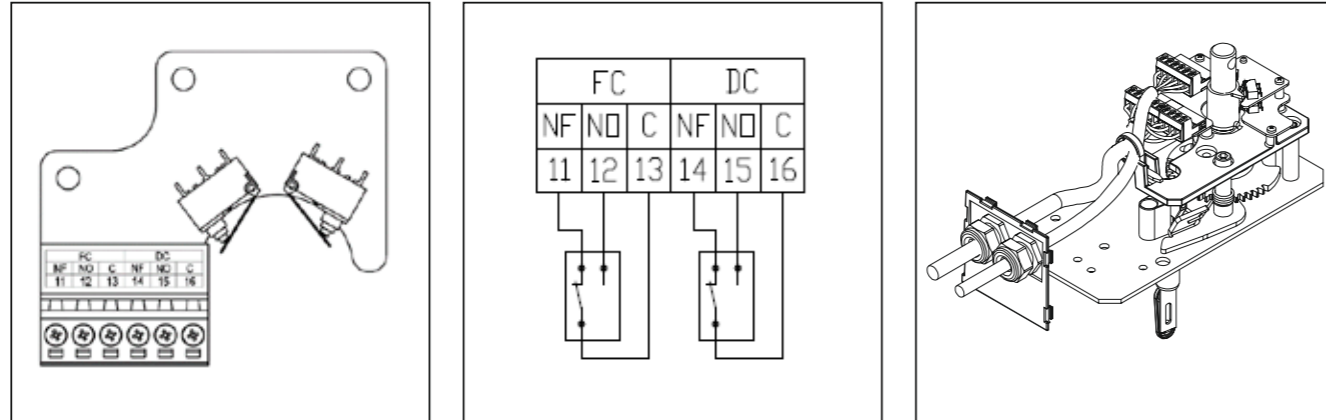

FC = Limit switch - end
DC = Limit switch - start

C = common
NO = normally open

NF = normally closed

ELECTRICAL SPECIFICATIONS	FD FUSE ONLY	FD FUSE ONLY UPGRADABLE TO SOLENOID ACTUATOR
Nominal voltage	N/A	Solenoid: 24/48 VDC (automatic change on the electronic card)
Power	N/A	Dual voltage SOLENOID: • Break of current: P _{nom} = 1.6W • Emission of current: P _{max} = 3.5 W
Switching capacity	1mA...500mA, 5VDC...48VDC	1mA...500mA, 5VDC...48VDC
Blade closure time Blade opening time	Spring: 1 second Manual	Spring: 1 second
Degree of protection	IP 42	IP 42

OTHER MECANISMS

Belimo

Operation

Damper is delivered in closed position. When electric actuator is connected to the power supply damper will open. When the damper reaches the end position (damper open), in which is it blocked, the electromotor will stop. Closing fire damper takes place automatically when a power failure occurs. Thermal tripping device that comes with fire damper causes power circuit break at a temperature of 72 °C (inside or outside duct). If checking is needed for proper functioning of fire damper, pushing the switch on the thermal tripping device will close damper. When switch on tripping device is released, the damper will open.



Damper can be opened without connecting to a voltage with enclosed handle turning in the direction of the arrow on electric actuator (clockwise). Damper can be locked in the desired position by fast turning back handle a quarter of a turn (counterclockwise) for Belimo BF, and by pulling brake on Belimo BFL and BFN. To unlock the electromotor, turn handle clockwise for a quarter of a turn for Belimo BF, or release brake for Belimo BFL and BFN. After release, damper will be closed by return spring. When damper is opened manually, electric actuator will not move the damper into closed position after power failure.

Wiring diagram

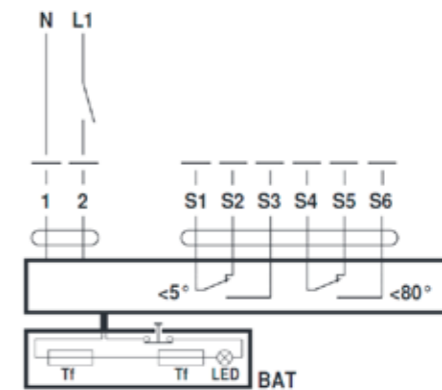

1	negative (direct-current) or neutral (alternating current)
2	positive (direct-current) or faze (alternating current)
S1	common micro switch closed damper
S2	normally closed micro switch closed damper
S3	normally open micro switch closed damper
S4	common micro switch open damper
S5	normally closed micro switch open damper
S6	normally open micro switch open damper
Tf1	temperature sensor on the outer side of the duct (ambienttemperature) max. 72°C
Tf2	temperature sensor on the inner side of the duct (temperature in the duct) max. 72°C
Tf3	temperature sensor on the inner side of the duct (temperature in the duct) max. 72°C

Type of Belimo actuator		BFL24-T	BFN24-T	BFL230-T	BFN230-T	BF24-T	BF230-T
Nominal voltage / power consumption	voltage	AC/DC 24V, 50/60Hz	AC 24V, 50/60Hz	AC 230V, 50/60Hz	AC 230V, 50/60Hz	AC/DC 24V, 50/60Hz	AC 230V, 50/60Hz
	opening	2,5 W	4 W	3,5 W	5 W	7 W	8.5 W
	holding	0,8 W	1,4 W	1,1 W	2,1 W	2 W	3 W
	for wire sizing	4 VA	6 VA	6,5 VA	10 VA	10 VA	11 VA
End switch		1 mA...3 A (0,5 A), DC 5 V...AC 250V	1 mA...3 A (0,5 A), DC 5 V...AC 250 V	1 mA...3 A (0,5 A), DC 5 V...AC 250 V	1 mA...3 A (0,5 A), DC 5 V...AC 250 V	1 mA...6 A (3 A), DC 5 V...AC 250 V	1 mA...3 A (0,5 A), DC 5 V...AC 250 V
Running time	motor	<60 s	<60 s	<60 s	<60 s	<120 s	<120 s
	spring-return	~20 s	~20 s	~20 s	~20 s	~16 s	~16 s
Ambient temperature range		min. -30°C, max. 50°C					

SCHISCHEK ExMax

Operation

Damper is delivered in closed position. When electric actuator is connected to the power supply damper will open. When the damper reaches the end position (damper open), in which it is blocked, the electromotor will stop. Closing fire damper takes place automatically when a power failure occurs. Thermal tripping device that comes with fire damper causes power circuit break at a temperature of 72 °C (inside or outside duct). If checking is needed for proper functioning of fire damper, pushing the switch on the thermal tripping device will close damper. When switch on tripping device is released, the damper will open.



Damper can be opened without connecting to a voltage with enclosed Allen key, by turning in the direction of the arrow on electric actuator (clockwise). After release of Allen key, damper will go to closed position.

Type Examination Certificate Number: EXA 14 ATEX0064X

Equipment complies with the essential health and safety requirements relating to the design and construction of equipment intended to use in potentially explosive atmospheres given in annex II of the directive 94/9/EC.

II - 2G - IIC - T6

II - 2D - IIC - T80°

Wiring diagram

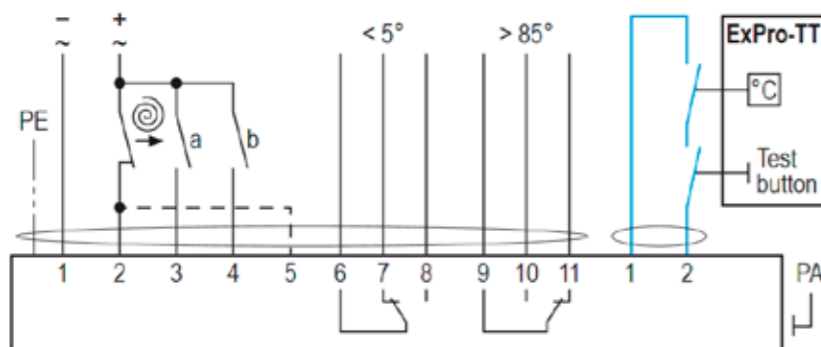

EVOLUTION / SERVICE KITS

	Designation	Code	
Fuse only mechanism	Fuse kit	FD-JHERM-72	
	Double contact S kit	FD-S-KIT	
Upgradeable to solenoid	4-contacts S2 kit	FD-DS-KIT	
	Solenoid current emission kit	FD-EMS-KIT	
	Solenoid current break kit	FD-EMP-KIT	

MAINTENANCE

- Provide at least one annual check of the damper
- After each intervention, provide a systematic cleaning of dust and especially the solenoid and its movable plate
- Check the if the electrical terminals are tightened