

THT



CJTHT/PLUS



THT-IMP-0



# FANS FOR THE SMOKE EXTRACTION

400°C/2h - 300°C/1h - 200°C/2h



EN-12101-3-2002  
Powered smoke and  
heat exhaust ventilators  
for use in Construction Works





## OUR COMMITMENT TO THE ENVIRONMENT

Sodeca has begun a new stage of study and design of new trends in ventilation which will help to preserve the environment and to make the energy saving which so much concerns today's society.

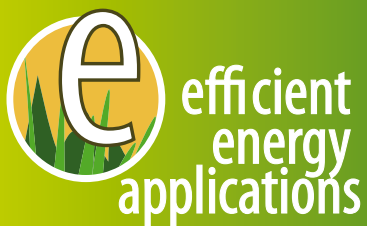

To obtain an **improvement in energy efficiency** of fans and of ventilation facilities, the engineering department of Sodeca has **balanced the energy consumption of the fans** with their maximum performance, in the habitual areas of work. This has required a restructuring of the curves and their presentation in this and future Sodeca catalogues.

**SODECA** has concentrated its activity on the production of industrial fans, ventilation systems and extractors for the removal of smoke in case of fire since 1983, when it was founded.

**SODECA's** fans and extractors are present in all European countries and in many parts of the world, thanks to the quality of the product and the methods of research and development used.

Our quality procedures used and certified by BUREAU VERITAS, in accordance with ISO 9001:2008, are another of the reasons which make **SODECA** one of the best and most renowned fan manufacturers in Europe.

Without a doubt, the most important factor to achieve our objectives is the human factor, the great professionals who work at your service, offering not only ventilation equipment but also solutions to any ventilation need required by our customers.

We sincerely offer you the possibility of visiting our facilities in Sant Quirze de Besora, with over 16,000 square metres of built area, where you will be able to see our fan manufacture with perfect clarity and with the highest standards of quality, complying with the ISO and AMCA standards.

This catalogue is only a small part of our possibilities. Do not hesitate to contact us. We will put all our experience and our human resources at your disposal.



*installations  
headquarters of  
SODECA s.a.,  
at Sant Quirze  
de Besora and  
manufacturing plant  
in Santiago  
de Chile.*



# FANS FOR THE SMOKE EXTRACTION AND OVERPRESSURE SYSTEMS



Thanks to the knowledge acquired during our 25 years' experience in the manufacture of fans for continuous working at high temperature, SODECA has become specialised in the manufacture of fans for the removal of smoke in case of fire and overpressure systems for the control of smoke in facilities for escape routes in case of fire.

If our manufacturing systems are certified by external quality certification organisations such as BUREAU VERITAS, the quality controls for the manufacturing processes and control of the fans for removing smoke at a temperature are also completely audited by independent organisations such as APPLUS, to ensure the correct functioning and compliance with the regulations and technical characteristics of the fans.

All our fans for removing smoke comply with the demands of the European Standard EN-12101-3-2002 "Powered smoke and heat exhaust ventilators for use in Construction Works", and are certified by an independent laboratory and accredited by the European Directives

## Summary of approvals and certificates:

■ They are delivered with the F-400 authorisation, and are suitable for applications F-300 and F-200

Series	Type	S2 Service			EC mark		
		F200 200°C-120min	F300 300°C-120min	F400 400°C-120min	F200 (120min)	F300 (60min)	F400 (120min)
THT - THT/ATEX	AXIAL FAN	x	x	x	0370-CPD-0514	0370-CPD-0973	0370-CPD-0305
CJTHT/PLUS	AXIAL FAN	x	x	x	0370-CPD-0515	0370-CPD-0974	0370-CPD-0312
CJTHT - CJTHT/ATEX	AXIAL FAN	x	x	x	0370-CPD-0515	0370-CPD-0974	0370-CPD-0312
CJTHT/DUPLEX/ATEX	AXIAL FAN		x	x		0370-CPD-0974	0370-CPD-0312
THT/IMP	AXIAL FAN IMPULSIONS	x	x	x	0370-CPD-0394	0370-CPD-0822	0370-CPD-0822
VST	TUNNEL JETFAN			x			1511-CPD-0128
VMSF	AXIAL FAN			x			1511-CPD-0104
CI	CENTRIFUGAL FAN IMPULSIONS		x			0370-CPD-0715	
HTMF	AXIAL ROOF FAN		x	x		0370-CPD-0544	0370-CPD-0544
CJBDT	CENTRIFUGAL FAN		x	x		0370-CPD-0888	0370-CPD-0580
CBDT	CENTRIFUGAL FAN		x	x		0370-CPD-0888	0370-CPD-0580
TCR	CENTRIFUGAL FAN		x	x		0370-CPD-0384	0370-CPD-0384
CTMP	CENTRIFUGAL FAN		x	x		0370-CPD-0397	0370-CPD-0397
CJS	CENTRIFUGAL FAN		x	x		0370-CPD-0398	0370-CPD-0398
CJMD	CENTRIFUGAL FAN		x	x		0370-CPD-0399	0370-CPD-0399
TCR/R	CENTRIFUGAL FAN	■	■	x			0370-CPD-0400
CJTCR/R	CENTRIFUGAL FAN	■	■	x			0370-CPD-0401
TCMP	CENTRIFUGAL FAN	■	■	x			0370-CPD-0313
CJMP	CENTRIFUGAL FAN	■	■	x			0370-CPD-0402
CJTX-C	CENTRIFUGAL FAN	■	■	x			0370-CPD-0468
CJSX	CENTRIFUGAL FAN	■	■	x			0370-CPD-0503
CJSRX	CENTRIFUGAL FAN	■	■	x			pending
CSX	CENTRIFUGAL FAN	■	■	x			pending
CJLINE	CENTRIFUGAL FAN	■	■	x			0370-CPD-0594
CJEC	CENTRIFUGAL FAN	■	■	x			0370-CPD-0382
CHT	CENTRIFUGAL ROOF FAN	■	■	x			0370-CPD-0897
CVT	CENTRIFUGAL ROOF FAN	■	■	x			0370-CPD-0897

# INSIDE

Installation of fan inside fire danger zone

<p><b>THT</b></p>  <p>Cased axial fans 400°C/2h, 300°C/1h and 200°C/2h</p> <p>12</p>	<p><b>CJTHT/PLUS</b></p>  <p>400°C/2h, 300°C/1h y 200°C/2h extraction units with built-in noise reducer</p> <p>20</p>	<p><b>CJTHT</b></p>  <p>400°C/2h, 300°C/1h and 200°C/2h axial extraction units with soundproofed box</p> <p>24</p>	<p><b>CJTHT/DUPLEX/ATEX</b></p>  <p>400°C/2h extraction units, with ATEX certification, category 2 Ex II G in accordance with Spanish Low Voltage Regulation ITC 29 ATEX and NBE-CP/96 for Zone 1 and 2 rated car parks.</p> <p>30</p>
<p><b>THT/IMP</b></p>  <p>400°C/2h, 300°C/1h and 200°C/2h single-direction or reversible long-range impulsion fans with circular or rectangular design</p> <p>78</p>	<p><b>JETFAN TUNNEL</b></p>  <p>Powerful Jet fans especially designed for tunnel ventilation. 400°C/2h, 300°C/1h and 200°C/2h Certificates</p> <p>82</p>	<p><b>VMSF</b></p>  <p>Cased high-pressure axial fans, certified 400°C/2h</p> <p>86</p>	<p><b>CI</b></p>  <p>300°C/1h centrifugal induction fans.</p> <p>88</p>
<p><b>HTMF</b></p>  <p>Multifunctional 400°C/2h and 300°C/1h roof fans</p> <p>90</p>	<p><b>CJBDT</b></p>  <p>Extraction units to work inside fire danger zones at 400°C/2h and 300°C/1h, with soundproofed box</p> <p>95</p>	<p><b>CBDT</b></p>  <p>Centrifugal double inlet and direct motor fans for working inside fire danger zones at 400°C/2h and 300°C/1h, with possibility of single-phase motor</p> <p>95</p>	<p><b>TCR</b></p>  <p>400°C/2h and 300°C/1h centrifugal fans with backward-curved impeller</p> <p>99</p>
<p><b>CTMP</b></p>  <p>400°C/2h and 300°C/1h centrifugal fans with multi-blade impeller</p> <p>102</p>	<p><b>CJS</b></p>  <p>400°C/2h and 300°C/1h extraction units with exchangeable hatches</p> <p>105</p>	<p><b>CJMD</b></p>  <p>400°C/2h and 300°C/1h extraction units with linear inlet and outlet</p> <p>108</p>	

## OUTSIDE

Installation of fan outside fire danger zone

### TCR/R



400°C/2h centrifugal fans with backward-curved impeller.

112

### CJTCR/R



400°C/2h extraction units with backward-curved impeller.

112

### TCMP



400°C/2h centrifugal fan with multi-blade impeller.

117

### CJMP



400°C/2h extraction units with multi-blade impeller

117

### CJTX-C



400°C/2h extraction units with inside belt-driven motor and automatic belt tensing device

123

### CJSX



400°C/2h belt-driven extraction units with single-inlet fan

132

### CJSRX



400°C/2h centrifugal fans with backwards-curved impeller

138

### CSX



400°C/2h centrifugal belt-driven fan

138

### CJLINE



400°C/2h extraction units with linear inlet and outlet

148

### CJEC



400°C/2h Extraction hoods for kitchens and 2-speed motor

153

### CHT



400°C/2h centrifugal roof fans with horizontal outlet air, hood in aluminium

156

### CVT



400°C/2h centrifugal roof fans with vertical outlet air, hood in aluminium

156

## KIT SOBREPRESIÓN FOR ESCAPE ROUTES



**KIT DE SOBREPRESIÓN**

**KIT SOBREPRESIÓN WITH RESERVE FAN**

162



# FULFILMENT OF STANDARDS

**SODECA's fans and extractors comply with the following standards:**

## QUALITY

<b>ISO 9001:2008</b>	Sistemas de gestión de la calidad. Requisitos. Quality management systems -- Requirements
----------------------	--

## TESTS

<b>ISO 5801</b>	Ventiladores industriales. Ensayos de comportamiento en circuitos normalizados Industrial fans -- Performance testing using standardized airways
<b>AMCA 210-99</b>	Ventiladores industriales. Métodos de ensayos de ventiladores y su representación de ensayos. Laboratory Methods of Testing Fans for Aerodynamic Performance Rating
<b>UNE 100212:1990</b>	Fans. Devices and installations for testing fans.
<b>ISO 13350</b>	Ventiladores industriales. Ensayos de comportamiento de ventiladores de chorro. Industrial fans -- Performance testing of jet fans
<b>ISO 13348</b>	Industrial fans -- Tolerances, methods of conversion and technical data presentation

## FANS FOR HIGH TEMPERATURES

<b>EN 12101-3:2002</b>	Sistemas de control de humos y calor. Parte 3: Especificaciones para aireadores extractores de humos y calor mecánicos. Smoke and heat control systems - Part 3: Specification for powered smoke and heat exhaust ventilators
------------------------	--

## ACOUSTICS

<b>ISO 3744</b>	Acústica. Determinación de los niveles de potencia acústica de fuentes de ruido a partir de la presión acústica. Método de ingeniería para condiciones de campo libre sobre un plano reflectante. Acoustics -- Determination of sound power levels of noise sources using sound pressure -- Engineering method in an essentially free field over a reflecting plane
-----------------	--

## BALANCE AND VIBRATIONS

<b>ISO 1940-1</b>	Vibraciones mecánicas. Calidad de equilibrado Mechanical vibration -- Balance quality requirements for rotors in a constant (rigid) state -- Part 1: Specification and verification of balance tolerances
<b>ISO 10816-1</b>	Vibraciones mecánicas. Evaluación de las vibraciones de máquinas Mechanical vibration -- Evaluation of machine vibration by measurements on non-rotating parts -- Part 1: General guidelines
<b>ISO 14694</b>	Ventiladores industriales. Especificaciones para equilibrado y niveles de vibración Industrial fans -- Specifications for balance quality and vibration levels

## SAFETY (Declaration of EC Compliance)

<b>EN ISO 12100-1</b>	Seguridad de las máquinas. Conceptos básicos, principios generales para el diseño. Parte 1: Terminología básica, metodología. Safety of machinery -- Basic concepts, general principles for design -- Part 1: Basic terminology, methodology
<b>EN ISO 12100-2</b>	Seguridad de las máquinas. Conceptos básicos, principios generales para el diseño. Parte 2: Principios técnicos: Safety of machinery -- Basic concepts, general principles for design -- Part 2: Technical principles
<b>EN 60204-1</b>	Seguridad de las máquinas. Equipo eléctrico de las máquinas. Parte 1: Requisitos generales. Safety of machinery - Electrical equipment of machines - Part 1: General requirements
<b>EN 294</b>	Seguridad de máquinas. Distancias de seguridad para impedir que se alcancen zonas peligrosas con los miembros superiores Safety of machinery; safety distances to prevent danger zones from being reached by the upper limbs
<b>ISO 13857</b>	Seguridad de máquinas. Distancias de seguridad para impedir que se alcancen zonas peligrosas con los miembros superiores e inferiores. Safety of machinery -- Safety distances to prevent danger zones being reached by upper and lower limbs
<b>UNE 100250</b>	Industrial fans. Mechanical safety of fans (equivalent ISO12499)
<b>ISO 12499</b>	Ventiladores industriales. Seguridad mecánica en los ventiladores Industrial fans -- Mechanical safety of fans -- Guarding

## DIRECTIVES

<b>2006/42/CE Directive</b>	Directiva de máquinas Machinery Directive
<b>2006/95/CE Directive</b>	Directiva de baja tensión Low Voltage Directive
<b>2004/108/CE Directive</b>	Directiva compatibilidad electromagnética EMC Directive
<b>89/106/EC Directive</b>	Directiva productos de construcción Construction Products Directive (CPD)

## ATEX EXECUTIONS

<b>ATEX 94/9/EC Directive.</b>	Aparatos y sistemas de protección para uso en atmósferas potencialmente explosivas Equipment and protective systems intended for use in potentially explosive atmospheres
<b>EN 14986</b>	Diseño de ventiladores para trabajar en atmósferas potencialmente explosivas. Design of fans working in potentially explosive atmospheres
<b>EN 13463-1</b>	Equipos no eléctricos destinados a atmósferas potencialmente explosivas. Parte 1: Requisitos y metodología básica. Non-electrical equipment for use in potentially explosive atmospheres - Part 1: Basic method and requirements
<b>EN 1127-1</b>	Atmósferas explosivas. Prevención y protección contra la explosión. Parte 1: Conceptos básicos y metodología. Explosive atmospheres - Explosion prevention and protection - Part 1: Basic concepts and methodology

## Smoke extraction for: **CAR PARKS**

Method of smoke extraction by means of fans certified for work at temperature during a specific period of time according to classification and certification. This method is habitually applied in blocks, shopping centres, tunnels, car parks and other large buildings and with large open areas, also in industrial buildings with a high risk of fire and for smoke extraction in industrial kitchens.



### FAN INSIDE

Installation of fan inside fire danger zone



### FAN OUTSIDE

Installation of fan outside fire danger zone



### JET FAN TYPE IMPULSION FAN

Installation of impulsion fan inside fire danger zone



## Smoke extraction for: **INDUSTRIAL KITCHENS**

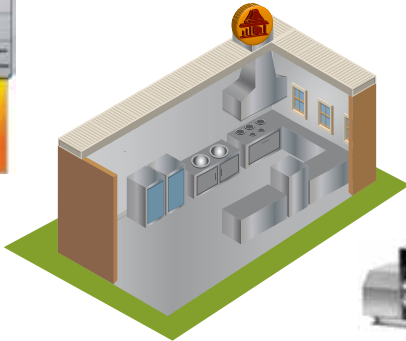

Fans suitable for use in industrial kitchens  
For the correct application of the standard:

- C.T.E. Technical Building Code Basic SI Document for fire safety Basic HS Document for health and safety



## Smoke extraction for: **INDUSTRIAL BUILDINGS**



Fans suitable for use in industrial buildings  
For the correct application of the standard:

- Regulation for Fire Safety in Industrial Buildings, Royal Decree 2267/2004, UNE-23585:2004 Fire Safety



## Control of smoke by differential pressure for: **ESCAPE ROUTES**



Overpressure smoke control method; this system consists of pressurization by means of the injection of air in spaces which are used as escape routes for people in case of fire, such as stair wells, passageways, corridors, elevators, etc. Above all in densely occupied tall buildings. This method is based on smoke control by means of the speed of air and the artificial barrier which is created by excess air pressure over smoke, so that it cannot enter escape routes. In accordance with standard EN-12101-6-2006

STAIRWELL KIT SOBREPRESION FOR THREE-PHASE EQUIPMENT



STAIRWELL KIT SOBREPRESION FOR SINGLE-PHASE EQUIPMENT



KIT SOBREPRESION WITH RESERVE FAN





## Smoke extraction for: **TUNNELS**

### TUNNEL VENTILATION

Tunnels play an important part in the global development of economies, contributing to the creation of large infrastructures and the improvement of urban communications. Most tunnel ventilation covers road tunnels, metro tunnels and railway tunnels.

The safety and air quality requirements are the most important aspects in the demand for tunnel ventilation, both for new constructions and in the improvement and adaptation of old infrastructures.

Although the main objective of tunnel ventilation is safety and smoke control in case of fire, the control of emissions of combustion gases from vehicles also plays an important part.



### LATEST TUNNEL INSTALLATIONS

*Reference:*  
**RENTERIA TUNNEL VARIANT (GUIPUZCOA)**  
Longitudinal ventilation of the tunnel, using Tunnel Jetfan type fans certified for 400°C/2h. Model THT/IMP-C-125-4T

*Reference:*  
**PLAZA DE LUGO TUNNEL IN A CORUÑA**  
Longitudinal ventilation of the tunnel, using Tunnel Jetfan type fans certified for 400°C/2h. Model THT/IMP-C-125-4T

*Reference:*  
**PLAZA ESPAÑA TUNNEL IN FERROL**  
Longitudinal ventilation of the tunnel, using Tunnel Jetfan type fans certified for 400°C/2h. Model THT/IMP-C-100-4T

*Reference:*  
**LINE 9 BARCELONA UNDERGROUND RAILWAY**  
Ventilation of different stations and ventilation shafts, using different sizes of fans certified for 400°C/2h from the THT series

*Reference:*  
**METRO WARSAW**  
Ventilation of different stations with VST Tunnel Jetfan fans certified for 400°C/2h. Model: VST-1600-4T-100 for an airflow of 193,000 m³/h with a 75Kw motor

*Reference:* **TUNNELS HIGHWAY C-17 in Ripoll (Girona-Spain)**  
Longitudinal ventilation of the tunnel using fans type Tunnel Jetfan certified for 400°C/2h. Model VST-1400-7-4-100

## TUNNEL VENTILATION SYSTEMS

There are basically three ways of ventilating tunnels:

**Longitudinal ventilation:** The air flow goes in the same direction as the axis of the tunnel. The air enters one of the ends of the tunnel and leaves at the other end. This is used in tunnels that are not excessively long, up to two kilometres in severe conditions and up to five kilometres in not-so-severe conditions, or if the traffic is all in one direction. This ventilation can be divided into a number of sections with intermediate extractions and injections of fresh air, in this case, the system of ventilation can be used for tunnels of greater length, up to ten kilometres.

Longitudinal Ventilation

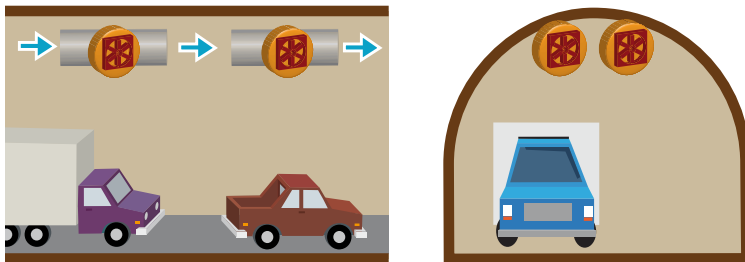

In normal practice, reversible fans are used, so as to be able to adapt the direction of circulation of the air according to the traffic needs, making it possible to compensate for the piston effect caused by the passage of vehicles through the tunnel.

**Transverse ventilation:** The air flow direction is transverse to the axis of the tunnel. Clean air is injected uniformly along the entire length of the tunnel and by means of one or several channels, and the extracted air is also drawn out along the length of the entire tunnel and in a uniform manner. So as to limit losses of load, these ducts are divided transversely into independent sections of between 1000 and 1600 metres. The best system consists of blowing in fresh air through the sides of the traffic surface and extracting the used air from the upper part of the tunnel.

Transverse Ventilation

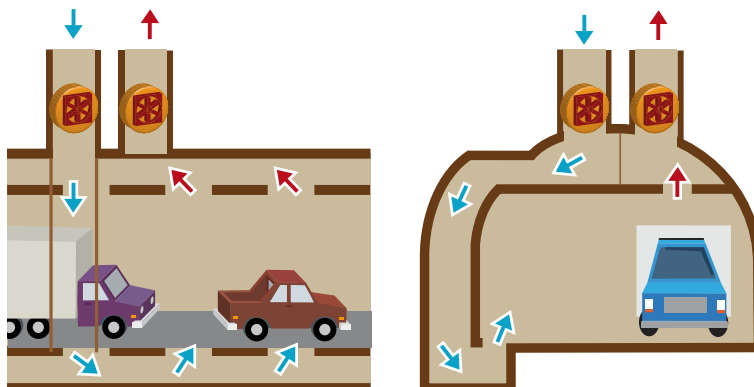

This system is considered to be the safest and most comfortable; it is independent of the influence of weather, the wind speed at the inlets and of the air speed caused by the vehicles. Even so, this system is the most expensive for investment and for the operating costs.

It is generally used in road tunnels of medium length and long tunnels with high traffic loads.

**Semi-Transverse ventilation:** The fresh clean air is injected in a direction that is transverse to the axis of the tunnel, by means of a parallel channel running along the whole length of the tunnel and the used air leaves through the two ends of the tunnel.

Semi-Transverse Ventilation

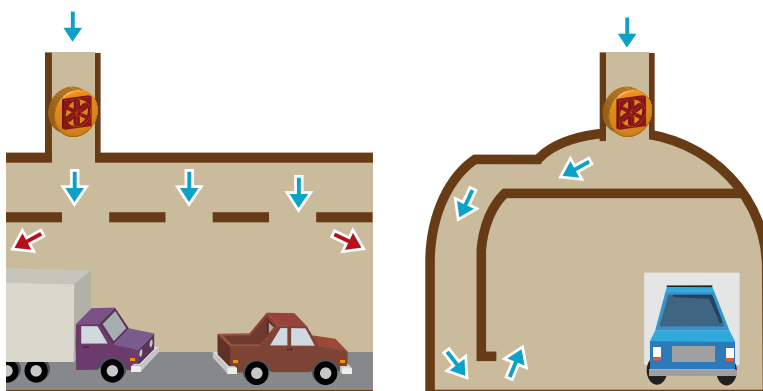

This system has the advantage of being able to make a reversible system so that it is possible, in the case of a fire, to invert the direction of air flow and in this way extract the smoke and gases from the fire through the upper part of the tunnel.

It is generally used in road tunnels of medium length with not very high traffic loads.

# THT



Detail THT/Atex

**THT: Cased axial fans 400°C/2h, 300°C/1h and 200°C/2h**

**THT/ATEX: Cased axial fans 400°C/2h, 300°C/1h and 200°C/2h with ATEX certification**

Cased axial fans with short casing for working inside fire danger zones, 400°C/2h. THT/ATEX: with ATEX certification, category 3 Ex II3G. In accordance with Spanish Low Voltage Regulation ITC 29 ATEX for Zone 2 rated car parks.

**Fan:**

- Sheet steel long casing. THT/ATEX: with aluminium strip in the impeller area in accordance with Standard EN-14986:2005
- Turnable cast aluminium impellers.
- Approval according to Standard EN-12101-3-2002, certificate no.: 0370-CPD-0305
- Airflow direction from motor to impeller

**Motor:**

- Class H motors, ongoing use S1 and emergency use S2, with ball bearings, IP55 protection, and one or two speeds depending on the model.
- Three-phase 230/400V.-50Hz. (up to 4CV.) and 400/690V.-50Hz. (power over 4CV.)
- Max. temperature of air for transport: S1 Service -20°C+ 40°C for ongoing use, S2 Service 200°C/2h, 300°C/2h, 400°C/2h

**Finish:**

- Anticorrosive finish in polyester resin, polymerised at 190°C, after alkaline degreasing and phosphate-free pre-treatment.

**On request:**

- Long-casing fans with inspection hatch
- 100% reversible impellers.



## Order code

From size 40 to size 100

**THT — 56 — 4T — 2 — F-400**

THT: Cased axial fans 400°C/2h, 300°C/1h and 200°C/2h

THT/ATEX: Cased axial fans 400°C/2h, 300°C/1h and 200°C/2h with ATEX certification

THT/CL: Cased axial fans 400°C/2h, 300°C/1h and 200°C/2h with long casing, equipped with an inspection door

Impeller diameter in cm.

Number of motor poles

- 2=2900 r/min. 50 Hz
- 4=1400 r/min. 50 Hz
- 6=900 r/min. 50 Hz
- 8=750 r/min. 50 Hz
- 12=500 r/min. 50 Hz

T=Three-phase

Power motor (c.v.)

F-200 Officially approved 200°C/2h  
 F-300 Officially approved 300°C/1h  
 F-400 Officially approved 400°C/2h  
 CAT3: With ATEX certification, Category 3 Ex II3G.

From size 125 to size 160

**THT — 125 — 4T — 15 — 9-10 — F-400**

THT: Cased axial fans 400°C/2h, 300°C/1h and 200°C/2h

THT/CL: Cased axial fans 400°C/2h, 300°C/1h and 200°C/2h with long casing, equipped with an inspection door

Impeller diameter in cm.

Number of motor poles

- 2=2900 r/min. 50 Hz
- 4=1400 r/min. 50 Hz
- 6=900 r/min. 50 Hz
- 8=750 r/min. 50 Hz
- 12=500 r/min. 50 Hz

T=Three-phase

Power motor (c.v.)

Number of blades  
 Angle of inclination of the blades

- 3 blades
- 6 blades
- 9 blades

F-200 Officially approved 200°C/2h  
 F-300 Officially approved 300°C/1h  
 F-400 Officially approved 400°C/2h  
 CAT3: With ATEX certification, Category 3 Ex II3G.

### Technical characteristics

Model	Speed (r/min)	Maximum admissible current (A)			Power installed (kW)	Airflow maximum (m³/h)	Sound pressure level dB(A)	Approx. weight (Kg)	
		230V	400V	690V				Long	Short
THT-40-2T-1,5	2880	4,70	2,70		1,10	7050	76	33	31
THT-40-2/4T-1,5	2920/1460		2,90/2,10		1,10/0,25	7050/3500	76/61	34	32
THT-40-2T-2	2880	5,90	3,40		1,50	8450	77	35	33
THT-40-2/4T-2	2940/1460		4,40/1,40		1,50/0,37	8450/4200	77/62	35	33
THT-40-4T-0,75	1410	2,73	1,57		0,55	4850	64	32	29
THT-40-6T-0,75	960	4,10	2,40		0,55	3150	53	37	34
THT-40-6/12T-0,75	940/440		1,60/0,55		0,55/0,09	3150/1450	53/38	41	38
THT-45-2T-2	2880	5,90	3,40		1,50	10050	78	38	34
THT-45-2/4T-2	2940/1460		5,70/1,80		1,50/0,37	10050/5050	78/63	37	34
THT-45-2T-3	2900	8,70	5,00		2,20	11900	80	39	36
THT-45-2/4T-3	2930/1450		4,40/1,40		2,20/0,60	11900/5950	80/65	39	36
THT-45-4T-0,75	1410	2,73	1,57		0,55	7650	68	34	30
THT-45-6T-0,75	960	4,10	2,40		0,55	5050	55	38	35
THT-45-6/12T-0,75	940/440		1,60/0,55		0,55/0,09	5050/2350	55/40	42	39
THT-50-2T-4	2880	11,20	6,50		3,00	13850	82	49	42
THT-50-2/4T-4	2920/1440		6,70/2,00		3,00/0,80	13850/6950	82/67	51	44
THT-50-2T-5,5	2890		9,30	5,40	4,00	15900	83	65	57
THT-50-2/4T-6	2930/1450		10,00/3,20		4,50/1,30	16750/8400	83/68	67	60
THT-50-4T-1	1415	3,50	2,03		0,75	9750	69	37	33
THT-50-6T-0,75	960	4,10	2,40		0,55	7900	57	40	36
THT-50-6/12T-0,75	940/440		1,60/0,55		0,55/0,09	7900/3650	57/42	44	40
THT-56-2T-5,5	2920		9,50	5,50	4,00	20050	88	69	60
THT-56-2/4T-6	2930/1450		10,00/3,20		4,50/1,30	21250/10650	88/72	71	63
THT-56-2T-12	2950		19,20	11,00	9,00	28200	89	147	139
THT-56-2/4T-12	2920/1440		20,70/5,50		9,00/2,50	28200/14100	89/74	137	129
THT-56-4T-1	1430	3,50	2,00		0,75	11850	73	45	40
THT-56-4T-1,5	1430	4,80	2,80		1,10	13550	74	44	40
THT-56-4/8T-1,5	1440/710		2,90/1,40		1,10/0,25	13550/6750	74/59	48	43
THT-56-4T-2	1420	6,20	3,60		1,50	15450	75	48	43
THT-56-4/8T-2	1415/715		3,60/1,50		1,50/0,30	15450/7700	75/60	59	55
THT-56-6T-0,75	960	4,10	2,40		0,55	10900	62	44	39
THT-56-6/12T-0,75	940/440		1,60/0,55		0,55/0,09	10900/5050	62/47	48	43
THT-63-2T-12	2950		19,20	11,00	9,00	34250	90	161	143
THT-63-2/4T-12	2920/1440		18,50/5,50		9,00/2,50	34250/17800	90/75	151	133
THT-63-2T-22	2960		32,30	18,60	16,00	41650	91	188	170
THT-63-2/4T-22	2960/1480		32,30/8,90		16,00/4,00	41650/21550	91/76	188	170
THT-63-4T-1	1430	3,50	2,00		0,75	15200	73	49	43
THT-63-4T-1,5	1430	4,80	2,80		1,10	17800	74	51	45
THT-63-4/8T-1,5	1440/710		2,90/1,40		1,10/0,25	17800/8850	74/59	55	49
THT-63-4T-2	1420	6,20	3,60		1,50	20100	75	55	49
THT-63-4/8T-2	1415/715		3,60/1,50		1,50/0,30	20100/9950	75/60	70	60
THT-63-4T-3	1430	9,00	5,20		2,20	22300	76	64	54
THT-63-4/8T-3	1415/715		5,20/1,90		2,20/0,45	22300/11050	76/61	77	66
THT-63-4T-4	1430	11,40	6,60		3,00	24350	77	73	63
THT-63-4/8T-4	1425/710		6,80/2,20		3,00/0,60	24350/12100	77/62	86	77
THT-63-6T-0,75	960	4,10	2,40		0,55	14100	65	51	45
THT-63-6/12T-0,75	940/440		1,60/0,55		0,55/0,09	14100/6550	65/50	55	49
THT-63-6T-1	950	4,70	2,70		0,75	15950	66	54	48
THT-63-6/12T-1	940/440		2,20/0,87		0,75/0,15	15950/7400	66/51	61	55
THT-71-4T-1,5	1430	4,80	2,80		1,10	19550	78	58	52
THT-71-4/8T-1,5	1440/710		2,90/1,40		1,10/0,25	19550/9700	78/63	61	56
THT-71-4T-2	1420	6,20	3,60		1,50	22200	79	61	56
THT-71-4/8T-2	1415/715		3,60/1,50		1,50/0,30	22200/11050	79/64	76	67

### Technical characteristics

Model	Speed (r/min)	Maximum admissible current (A)		Power installed (kW)	Airflow maximum (m³/h)	Sound pressure level dB(A)	Approx. weight (Kg)		
		230V	690V				Long	Short	
THT-71-4T-3	1430	9,00	5,20	2,20	25850	81	70	61	
THT-71-4/8T-3	1415/715		5,20/1,90	2,20/0,45	25850/12850	81/66	82	74	
THT-71-4T-4	1430	11,40	6,60	3,00	29600	82	79	70	
THT-71-4/8T-4	1425/710		6,80/2,20	3,00/0,60	29600/14700	82/67	92	83	
THT-71-6T-0,75	960	4,10	2,40	0,55	16100	67	57	52	
THT-71-6/12T-0,75	940/440		1,60/0,55	0,55/0,09	16100/7450	67/52	61	56	
THT-71-6T-1	950	4,70	2,70	0,75	18050	68	61	55	
THT-71-6/12T-1	940/440		2,20/0,87	0,75/0,15	18050/8350	68/53	67	62	
THT-71-6T-1,5	940	5,50	3,20	1,10	20550	69	69	61	
THT-71-6/12T-1,5	950/470		3,00/1,15	1,10/0,18	20550/9500	69/54	77	69	
THT-80-4T-3	1430	9,00	5,20	2,20	25550	82	79	69	
THT-80-4/8T-3	1415/715		5,20/1,90	2,20/0,45	25550/12700	82/67	91	82	
THT-80-4T-4	1430	11,40	6,60	3,00	30400	83	88	78	
THT-80-4/8T-4	1425/710		6,80/2,20	3,00/0,60	30400/15100	83/68	101	92	
THT-80-4T-5,5	1435		8,40	4,80	4,00	32950	84	94	85
THT-80-4/8T-5,5	1455/725		9,30/3,40	4,00/0,80	32950/16350	84/69	127	118	
THT-80-6T-1,5	940	5,50	3,20	1,10	21600	72	78	69	
THT-80-6/12T-1,5	950/470		3,00/1,15	1,10/0,18	21600/7750	72/57	86	77	
THT-80-6T-2	945	7,40	4,30	1,50	26100	73	87	78	
THT-80-6/12T-2	950/460		4,60/1,90	1,50/0,25	26100/12100	73/58	91	82	
THT-80-6T-3	935	9,50	5,50	2,20	30000	74	94	84	
THT-80-6/12T-3	940/470		5,60/2,20	2,20/0,37	30000/13900	74/59	100	91	
THT-80-8T-0,75	700	3,60	2,10	0,55	19050	70	71	62	
THT-80-8T-1	710	4,80	2,80	0,75	20750	71	78	69	
THT-90-4T-4	1430	11,40	6,60	3,00	36150	87	110	93	
THT-90-4/8T-4	1425/710		6,80/2,20	3,00/0,60	36150/17950	87/72	124	106	
THT-90-4T-5,5	1435		8,40	4,80	4,00	41650	89	117	99
THT-90-4/8T-5,5	1455/725		9,30/3,40	4,00/0,80	41650/20700	89/74	150	132	
THT-90-4T-7,5	1460		12,60	7,30	5,50	46350	91	143	126
THT-90-4/8T-7,5	1455/725		12,80/4,60	5,50/1,10	46350/23000	91/76	157	140	
THT-90-4T-10	1460		17,70	10,20	7,50	50300	92	154	137
THT-90-4/8T-9	1455/725		15,60/6,30	6,70/1,50	48550/24100	92/77	157	140	
THT-90-6T-2	945	7,40	4,30	1,50	28900	77	110	92	
THT-90-6/12T-2	950/460		4,60/1,90	1,50/0,25	28900/13400	77/62	114	96	
THT-90-6T-3	935	9,50	5,50	2,20	34050	78	116	99	
THT-90-6/12T-3	940/470		5,60/2,20	2,20/0,37	34050/15750	78/63	123	105	
THT-90-6T-4	970	13,50	7,80	3,00	39050	79	142	124	
THT-90-6/12T-4	960/475		8,90/3,50	3,00/0,55	39050/18100	79/64	143	126	
THT-90-8T-1	710	4,80	2,80	0,75	23000	71	100	84	
THT-90-8T-2	710	7,80	4,50	1,50	30950	73	116	99	
THT-90-8T-3	710	11,40	6,60	2,20	30950	74	134	116	
THT-100-4T-7,5	1460		12,60	7,30	5,50	50950	92	151	131
THT-100-4/8T-7,5	1455/725		12,80/4,60	5,50/1,10	50950/25300	92/77	165	145	
THT-100-4T-10	1460		17,70	10,20	7,50	57650	93	162	142
THT-100-4/8T-9	1455/725		15,60/6,30	6,70/1,50	54900/27250	93/78	165	145	
THT-100-4T-15	1460		22,00	12,70	11,00	66500	94	215	195
THT-100-4/8T-15	1470/725		23,20/8,70	11,00/2,80	66500/33000	94/79	215	195	
THT-100-4T-20	1460		29,00	16,70	15,00	76450	95	230	210
THT-100-4/8T-20	1470/725		31,70/11,80	15,00/3,80	76450/37950	95/80	230	210	
THT-100-6T-3	935	9,50	5,50	2,20	37750	82	124	105	
THT-100-6/12T-3	940/470		5,60/2,20	2,20/0,37	37750/17500	82/67	130	112	
THT-100-6T-4	970	13,50	7,80	3,00	43550	83	150	130	
THT-100-6/12T-4	960/475		8,90/3,50	3,00/0,55	43550/20200	83/68	151	131	
THT-100-6T-5,5	970		11,00	6,40	4,00	47950	84	162	142
THT-100-6/12T-5,5	970/480		11,30/4,20	4,00/0,65	47950/22200	84/69	162	142	

### Technical characteristics

Model	Speed (r/min)	Maximum admissible current (A)			Power installed (kW)	Airflow maximum (m³/h)	Sound pressure level dB(A)	Approx. weight (Kg)	
		230V	400V	690V				Long	
THT-100-8T-2	710	7,80	4,50		1,50	34700	77	124	105
THT-100-8T-3	710	11,40	6,60		2,20	40600	77	142	122
THT-100-8T-4	710	15,60	9,00		3,00	40600	78	162	142
THT-125-4T/3-10	1460		17,70	10,20	7,50	58150	88	243	210
THT-125-4/8T/3-9	1455/725		15,60/6,30		6,70/1,50	58150/28900	88/68	243	210
THT-125-4T/3-15	1460		22,00	12,70	11,00	77450	89	294	266
THT-125-4/8T/3-15	1470/725		23,20/8,70		11,00/2,80	77450/38450	89/69	294	266
THT-125-4T/3-20	1460		29,00	16,70	15,00	91400	91	309	281
THT-125-4/8T/3-20	1470/725		31,70/11,80		15,00/3,80	91400/45350	91/71	309	281
THT-125-4T/3-25	1465		37,00	21,40	18,50	104400	91	377	334
THT-125-4T/3-30	1470		42,00	24,20	22,00	110500	92	391	348
THT-125-4/8T/3-27	1470/735		38,00/13,00		20,00/4,00	104400/51850	92/71	391	348
THT-125-4/8T/3-37	1475/735		51,00/20,60		27,00/6,00	120850/60000	93/72	472	429
THT-125-4T/3-40	1475		58,00	33,50	30,00	129300	93	472	429
THT-125-4/8T/3-40	1480/735		62,00/27,00		30,00/10,00	129300/64200	93/72	618	562
THT-125-4T/6-20	1460		29,00	16,70	15,00	85150	89	318	290
THT-125-4/8T/6-20	1470/725		31,70/11,80		15,00/3,80	85150/42300	89/68	318	290
THT-125-4/8T/6-22	1470/735		31,80/12,00		16,50/3,30	85150/42300	89/69	303	275
THT-125-4T/6-25	1465		37,00	21,40	18,50	92000	90	386	343
THT-125-4/8T/6-27	1470/735		38,00/13,00		20,00/4,00	98100/48700	90/69	400	357
THT-125-4T/6-30	1470		42,00	24,20	22,00	104150	90	400	357
THT-125-4/8T/6-37	1475/735		51,00/20,60		27,00/6,00	110250/54750	90/70	481	437
THT-125-4T/6-40	1475		58,00	33,50	30,00	117000	92	481	437
THT-125-4/8T/6-40	1480/735		62,00/27,00		30,00/10,00	117000/58100	92/71	627	571
THT-125-4T/6-50	1480		73,00	42,10	37,00	130450	93	529	473
THT-125-4T/9-25	1465		37,00	21,40	18,50	79750	88	395	352
THT-125-4/8T/9-22	1470/735		31,80/12,00		16,50/3,30	71150/35300	88/69	312	284
THT-125-4T/9-30	1470		42,00	24,20	22,00	97000	89	409	366
THT-125-4/8T/9-27	1470/735		38,00/13,00		20,00/4,00	88350/43900	89/70	409	366
THT-125-4/8T/9-37	1475/735		51,00/20,60		27,00/6,00	104100/51700	90/70	490	446
THT-125-4T/9-40	1475		58,00	33,50	30,00	104100	91	490	446
THT-125-4/8T/9-40	1480/735		62,00/27,00		30,00/10,00	104100/51700	91/71	636	580
THT-125-4T/9-50	1480		73,00	42,10	37,00	118350	93	538	482
THT-125-6T/3-4	970	13,50	7,80		3,00	50750	79	230	197
THT-125-6/12T/3-4	960/475		8,90/3,50		3,00/0,55	50750/23500	79/64	232	199
THT-125-6T/3-5,5	970		11,00	6,40	4,00	59850	80	242	209
THT-125-6/12T/3-5,5	970/480		11,30/4,20		4,00/0,65	59850/27750	80/65	243	210
THT-125-6T/3-7,5	970		12,40	7,20	5,50	68400	81	249	216
THT-125-6/12T/3-7,5	970/480		13,20/5,30		5,50/1,00	68400/31700	81/66	263	230
THT-125-6T/3-10	970		17,00	9,80	7,50	79150	83	274	246
THT-125-6/12T/3-10	960/470		20,00/9,00		7,50/1,40	79150/36650	83/68	294	266
THT-125-6T/3-15	955		26,00	15,00	11,00	89400	84	304	276
THT-125-6/12T/3-15	960/470		28,50/13,00		11,00/2,00	89400/41400	84/69	309	281
THT-125-6T/3-20	975		31,00	17,90	15,00	91700	85	377	334
THT-125-6/12T/3-24	970/480		36,00/14,50		17,50/3,50	91700/42450	85/70	472	429
THT-125-6T/6-5,5	970		11,00	6,40	4,00	51300	77	251	218
THT-125-6/12T/6-5,5	970/480		11,30/4,20		4,00/0,65	51300/23750	77/62	252	219
THT-125-6T/6-7,5	970		12,40	7,20	5,50	64250	77	258	225
THT-125-6/12T/6-7,5	970/480		13,20/5,30		5,50/1,00	64250/29750	77/62	272	239
THT-125-6T/6-10	970		17,00	9,80	7,50	72250	79	283	255
THT-125-6/12T/6-10	960/470		20,00/9,00		7,50/1,40	72250/33450	79/64	303	275
THT-125-6T/6-15	955		26,00	15,00	11,00	85450	81	313	285
THT-125-6/12T/6-15	960/470		28,50/13,00		11,00/2,00	85450/39600	81/66	318	290
THT-125-6T/6-20	975		31,00	17,90	15,00	96750	82	386	343
THT-125-6/12T/6-24	970/480		36,00/14,50		17,50/3,50	102650/47550	82/67	481	437

**Technical characteristics**

Model	Speed (r/min)	Maximum admissible current (A)			Power installed (kW)	Airflow maximum (m³/h)	Sound pressure level dB(A)	Approx. weight (Kg)	
		230V	400V	690V				Long	Short
THT-125-6T/9-10	970		17,00	9,80	7,50	68200	78	292	264
THT-125-6/12T/9-10	960/470		20,00/9,00		7,50/1,40	68200/31600	78/63	312	284
THT-125-6T/9-15	955		26,00	15,00	11,00	77550	81	322	294
THT-125-6/12T/9-15	960/470		28,50/13,00		11,00/2,00	77550/35900	81/66	327	299
THT-125-6T/9-20	975		31,00	17,90	15,00	92950	84	395	352
THT-125-6/12T/9-24	970/480		36,00/14,50		17,50/3,50	98650/45700	84/69	490	446
THT-140-6T/3-5,5	940		8,72	5,00	4,00	51000	83	279	242
THT-140-6T/3-7,5	960		12,20	7,00	5,50	67900	84	287	250
THT-140-6T/3-10	970		15,60	9,00	7,50	80100	85	339	300
THT-140-6T/3-15	970		23,30	13,50	11,00	96850	86	356	317
THT-140-6T/3-20	970		27,40	15,80	15,00	113350	88	436	386
THT-140-6T/6-7,5	960		12,20	7,00	5,50	62650	84	297	260
THT-140-6T/6-10	970		15,60	9,00	7,50	74650	85	349	310
THT-140-6T/6-15	970		23,30	13,50	11,00	91300	86	366	327
THT-140-6T/6-20	970		27,40	15,80	15,00	102550	87	445	396
THT-140-6T/6-25	975		34,40	19,90	18,50	114350	88	497	448
THT-140-6T/6-30	975		41,40	23,90	22,00	119100	89	506	457
THT-140-6T/9-10	970		15,60	9,00	7,50	62350	84	358	319
THT-140-6T/9-15	970		23,30	13,50	11,00	85050	86	375	336
THT-140-6T/9-20	970		27,40	15,80	15,00	91250	87	455	405
THT-140-6T/9-25	975		34,40	19,90	18,50	103750	88	506	458
THT-140-6T/9-30	975		41,40	23,90	22,00	118450	89	515	467
THT-140-6T/9-40	985		54,20	31,30	30,00	131950	91	673	611
THT-140-6T/9-50	980		66,40	38,30	37,00	138950	92	751	696
THT-140-8T/3-3	715	9,17	5,27		2,20	47200	78	279	242
THT-140-8T/3-4	710	12,50	7,20		3,00	56100	78	287	250
THT-140-8T/3-5,5	730		10,40	6,00	4,00	69400	79	337	298
THT-140-8T/3-7,5	730		13,80	8,00	5,50	80300	81	346	307
THT-140-8T/3-10	725		17,80	10,30	7,50	88300	82	357	318
THT-140-8T/6-3	715	9,17	5,27		2,20	47450	78	289	252
THT-140-8T/6-4	710	12,50	7,20		3,00	52000	79	297	260
THT-140-8T/6-5,5	730		10,40	6,00	4,00	61150	80	347	308
THT-140-8T/6-7,5	730		13,80	8,00	5,50	73250	81	356	317
THT-140-8T/6-10	725		17,80	10,30	7,50	82200	82	367	328
THT-140-8T/6-15	725		21,70	12,50	11,00	98100	83	453	404
THT-140-8T/9-4	710	12,50	7,20		3,00	47250	79	306	269
THT-140-8T/9-5,5	730		10,40	6,00	4,00	53000	79	356	317
THT-140-8T/9-7,5	730		13,80	8,00	5,50	64450	81	365	326
THT-140-8T/9-10	725		17,80	10,30	7,50	73900	82	376	337
THT-140-8T/9-15	725		21,70	12,50	11,00	94250	83	463	413
THT-140-8T/9-20	725		32,90	19,00	15,00	102750	86	516	468
THT-160-6T/3-10	970		15,60	9,00	7,50	76100	83	412	358
THT-160-6T/3-15	970		23,30	13,50	11,00	101350	85	429	375
THT-160-6T/3-20	970		27,40	15,80	15,00	119550	86	522	453
THT-160-6T/3-25	975		34,40	19,90	18,50	136650	87	574	504
THT-160-6T/3-30	975		41,40	23,90	22,00	152550	89	583	513
THT-160-6T/6-15	970		23,30	13,50	11,00	93500	85	440	386
THT-160-6T/6-20	970		27,40	15,80	15,00	111450	86	532	463
THT-160-6T/6-25	975		34,40	19,90	18,50	120400	87	584	515
THT-160-6T/6-30	975		41,40	23,90	22,00	136300	88	593	524
THT-160-6T/6-40	985		54,20	31,30	30,00	153050	89	768	669
THT-160-6T/6-50	980		66,40	38,30	37,00	170700	91	842	757
THT-160-6T/9-15	970		23,30	13,50	11,00	93100	85	450	396
THT-160-6T/9-20	970		27,40	15,80	15,00	104350	86	542	473
THT-160-6T/9-25	975		34,40	19,90	18,50	115650	87	594	525

**Technical characteristics**

Model	Speed (r/min)	Maximum admissible current (A)			Power installed (kW)	Airflow maximum (m³/h)	Sound pressure level dB(A)	Approx. weight (Kg)	
		230V	400V	690V				Long	Short
THT-160-6T/9-30	975		41,40	23,90	22,00	126900	88	603	534
THT-160-6T/9-40	985		54,20	31,30	30,00	145550	89	778	679
THT-160-6T/9-50	980		66,40	38,30	37,00	154850	90	852	768
THT-160-6T/9-60	985		84,50	48,80	45,00	176800	91	1067	968
THT-160-6T/9-75	985		100,00	57,70	55,00	192350	92	1112	1013
THT-160-8T/3-4	710	12,50	7,20		3,00	57700	77	356	304
THT-160-8T/3-5,5	730		10,40	6,00	4,00	70450	79	410	356
THT-160-8T/3-7,5	730		13,80	8,00	5,50	83700	80	419	365
THT-160-8T/3-10	725		17,80	10,30	7,50	97550	81	430	376
THT-160-8T/3-15	725		21,70	12,50	11,00	119850	83	530	461
THT-160-8T/6-5,5	730		10,40	6,00	4,00	70850	77	421	367
THT-160-8T/6-7,5	730		13,80	8,00	5,50	77650	79	430	376
THT-160-8T/6-10	725		17,80	10,30	7,50	91250	80	441	387
THT-160-8T/6-15	725		21,70	12,50	11,00	109350	82	540	471
THT-160-8T/6-20	725		32,90	19,00	15,00	122700	83	594	525
THT-160-8T/6-25	730		34,90	20,10	18,50	134700	84	741	642
THT-160-8T/9-7,5	730		13,80	8,00	5,50	70550	79	440	386
THT-160-8T/9-10	725		17,80	10,30	7,50	79100	80	451	397
THT-160-8T/9-15	725		21,70	12,50	11,00	103250	82	550	481
THT-160-8T/9-20	725		32,90	19,00	15,00	117350	83	604	535
THT-160-8T/9-25	730		34,90	20,10	18,50	125650	84	751	652
THT-160-8T/9-30	730		41,10	23,70	22,00	140650	85	776	677
THT-160-8T/9-40	730		56,30	32,50	30,00	157200	86	837	753

**Acoustic features**

The specified values are determined according to free field measurements of pressure and sound levels in dB(A) at an equivalent distance of twice the fan's span plus the impeller's diameter, with a minimum of 1.5 m.

Sound power Lw(A) spectrum in dB(A) via frequency band in Hz.

Model	63	125	250	500	1000	2000	4000	8000	Model	63	125	250	500	1000	2000	4000	8000
40-2-1,5	48	69	76	81	84	80	73	62	63-6-0,75	42	60	68	73	75	72	65	56
40-2-2	49	70	77	82	85	81	74	63	63-6-1	43	62	70	75	77	74	67	57
40-4-0,75	36	57	64	69	72	68	61	50	63-8-1,5	33	53	61	66	68	65	58	50
40-4-1,5	33	54	61	66	69	65	58	47	63-8-2	37	53	61	66	68	65	58	51
40-4-2	34	55	62	67	70	66	59	48	63-8-3	38	55	63	68	70	67	62	52
40-6	25	46	53	58	61	57	50	39	63-8-4	39	56	64	69	71	68	63	53
40-12	10	31	38	43	46	42	35	24	63-12-0,75	27	43	51	56	58	55	48	37
45-2-2	50	71	78	83	86	82	75	64	63-12-1	28	45	53	58	60	57	50	42
45-2-3	52	73	80	85	88	84	77	66	71-4-1,5	54	74	82	87	89	86	79	69
45-4-0,75	40	61	68	73	76	72	65	54	71-4-2	53	73	81	86	88	85	78	70
45-4-2	35	56	63	68	71	67	60	49	71-4-3	58	72	80	85	87	84	77	71
45-4-3	37	58	65	70	73	69	62	51	71-4-4	59	73	81	86	88	85	78	72
45-6	27	48	55	60	63	59	52	41	71-6-0,75	44	63	72	74	76	73	66	55
45-12	12	33	40	45	48	44	37	26	71-6-1	45	65	73	75	77	74	67	56
50-2-4	57	77	85	90	92	89	82	71	71-6-1,5	46	66	71	76	78	75	68	57
50-2-5,5	58	78	86	91	93	90	83	72	71-8-1,5	38	58	66	71	73	70	63	54
50-2-6	58	78	86	91	93	90	83	72	71-8-2	38	58	66	71	73	70	63	55
50-4-1	44	64	72	77	79	76	69	58	71-8-3	43	57	65	70	72	69	62	56
50-4-4	42	62	70	75	77	74	67	56	71-8-4	44	58	66	71	73	70	63	57
50-4-6	43	63	71	76	78	75	68	57	71-12-0,75	29	44	52	57	59	56	49	38
50-6	32	52	60	65	67	64	57	46	71-12-1	30	46	54	59	61	58	51	40
50-12	17	37	45	50	52	49	42	31	71-12-1,5	31	46	54	59	61	58	51	40
50-2-5,5	63	83	91	96	98	95	88	77	80-4-3	57	77	85	90	92	89	82	73
56-2-6	63	83	91	96	98	95	88	77	80-4-4	56	76	84	89	91	88	81	74
56-2-12	64	84	92	97	99	96	89	78	80-4-5,5	56	76	84	89	91	88	81	70
56-4-1	48	68	76	81	83	80	73	62	80-6-1,5	49	66	74	79	81	78	71	60
56-4-1,5	49	69	77	82	84	81	74	63	80-6-2	50	67	75	80	82	79	72	61
56-4-2	50	70	78	83	85	82	75	64	80-6-3	51	68	76	81	83	80	73	62
56-4-6	48	68	76	81	83	80	73	62	80-8-0,75	47	60	68	73	75	72	65	54
56-4-12	49	69	77	82	84	81	74	63	80-8-1	48	61	69	74	76	73	66	55
56-6	37	57	65	70	72	69	62	51	80-8-3	42	62	70	75	77	74	67	58
56-8-1,5	34	54	62	67	69	66	59	48	80-8-4	41	61	69	74	76	73	66	59
56-8-2	35	55	63	68	70	67	60	49	80-8-5,5	40	60	68	73	75	72	65	59
56-12	22	42	50	55	57	54	47	36	80-12-1,5	34	49	57	62	64	61	54	43
63-2-12	67	87	95	100	102	99	92	81	80-12-2	35	50	58	63	65	62	55	44
63-2-22	68	88	96	101	103	100	93	82	80-12-3	36	51	59	64	66	63	56	45
63-4-1	50	70	78	83	85	82	75	64	90-4-4	61	82	89	94	97	93	86	79
63-4-1,5	48	68	76	81	83	80	73	65	90-4-5,5	60	81	88	93	96	92	85	74
63-4-2	52	68	76	81	83	80	73	66	90-4-7,5	59	80	87	92	95	91	84	73
63-4-3	53	70	78	83	85	82	77	67	90-4-9	58	79	86	91	94	90	83	72
63-4-4	54	71	79	84	86	83	78	68	90-4-10	58	79	86	91	94	90	83	72
63-4-12	52	72	80	85	87	84	77	66	90-6-2	49	70	77	82	85	81	74	63
63-4-22	53	73	81	86	88	85	78	67	90-6-3	56	70	77	82	85	81	74	63

Acoustic features

Sound power Lw(A) spectrum in dB(A) via frequency band in Hz.

90-6-4	57	72	79	84	87	83	76	65	125-4/9-40	69	77	94	100	101	96	91	87
90-8-1	42	63	70	75	78	74	67	56	125-4/9-50	71	79	96	102	103	98	93	89
90-8-2	51	66	73	78	81	77	70	59	125-6/9-10	58	68	83	87	86	85	74	70
90-8-3	52	66	73	78	81	77	70	59	125-6/9-15	61	71	86	90	89	88	77	73
90-8-4	46	67	74	79	82	78	71	64	125-6/9-20	64	74	89	93	92	91	80	76
90-8-5,5	45	66	73	78	81	77	70	59	125-6/9-24	64	74	89	93	92	91	80	76
90-8-7,5	43	64	71	76	79	75	68	57	125-8/9-22	47	55	72	78	79	74	69	65
90-8-9	43	64	71	76	79	75	68	57	125-8/9-27	48	56	73	79	80	75	70	66
90-12-2	32	53	60	65	68	64	57	46	125-8/9-37	48	56	73	79	80	75	70	66
90-12-3	41	53	60	65	68	64	57	46	125-8/9-40	49	57	74	80	81	76	71	67
90-12-4	42	55	62	67	70	66	59	48	125-12/9-10	43	53	68	72	71	70	59	55
100-4-7,5	64	84	92	97	99	96	89	78	125-12/9-15	46	56	71	75	74	73	62	58
100-4-9	63	83	91	96	98	95	88	77	125-12/9-24	49	59	74	78	77	76	65	61
100-4-10	62	82	90	95	97	94	87	76	140-6/3-5,5	69	79	87	92	91	90	77	77
100-4-15	61	81	89	94	96	93	86	75	140-6/3-7,5	70	80	88	93	92	91	78	78
100-4-20	63	83	91	96	98	95	88	77	140-6/3-10	71	81	89	94	93	92	79	79
100-6-3	61	72	80	85	87	84	77	66	140-6/3-15	72	82	90	95	94	93	80	80
100-6-4	64	72	80	85	87	84	77	66	140-6/3-20	74	84	92	97	96	95	82	82
100-6-5,5	64	73	81	86	88	85	78	67	140-6/6-7,5	68	83	92	94	91	85	77	73
100-8-2	56	66	74	79	81	78	71	60	140-6/6-10	69	84	93	95	92	86	78	74
100-8-3	57	68	76	81	83	80	73	62	140-6/6-15	70	85	94	96	93	87	79	75
100-8-4	58	68	76	81	83	80	73	62	140-6/6-20	71	86	95	97	94	88	80	76
100-8-7,5	49	69	77	82	84	81	74	63	140-6/6-25	72	87	96	98	95	89	81	77
100-8-9	48	68	76	81	83	80	73	62	140-6/6-30	73	88	97	99	96	90	82	78
100-8-15	46	66	74	79	81	78	71	60	140-6/9-10	66	84	93	92	91	87	78	73
100-8-20	47	67	75	80	82	79	72	61	140-6/9-15	68	86	95	94	93	89	80	75
100-12-3	46	55	63	68	70	67	60	49	140-6/9-20	69	87	96	95	94	90	81	76
100-12-4	48	55	63	68	70	67	60	49	140-6/9-25	70	88	97	96	95	91	82	77
100-12-5,5	49	56	64	69	71	68	61	50	140-6/9-30	71	89	98	97	96	92	83	78
125-4/3-9	70	76	88	98	98	94	86	82	140-6/9-40	73	91	100	99	98	94	85	80
125-4/3-10	70	76	88	98	98	94	86	82	140-6/9-50	74	92	101	100	99	95	86	81
125-4/3-15	71	77	89	99	99	95	87	83	140-8/3-3	64	74	82	87	86	85	72	67
125-4/3-20	73	79	91	101	101	97	89	85	140-8/3-4	64	74	82	87	86	85	72	67
125-4/3-25	73	79	91	101	101	97	89	85	140-8/3-5,5	65	75	83	88	87	86	73	68
125-4/3-27	74	80	92	102	102	98	90	86	140-8/3-7,5	67	77	85	90	89	88	75	70
125-4/3-30	74	80	92	102	102	98	90	86	140-8/3-10	68	78	86	91	90	89	76	71
125-4/3-37	75	81	93	103	103	99	91	87	140-8/6-3	63	75	84	88	86	80	70	67
125-4/3-40	75	81	93	103	103	99	91	87	140-8/6-4	64	76	85	89	87	81	71	68
125-6/3-5,5	66	74	86	90	88	83	74	70	140-8/6-5,5	65	77	86	90	88	82	72	69
125-6/3-7,5	67	75	87	91	89	84	75	71	140-8/6-7,5	66	78	87	91	89	83	73	70
125-6/3-10	69	77	89	93	91	86	77	73	140-8/6-10	67	79	88	92	90	84	74	71
125-6/3-15	70	78	90	94	92	87	78	74	140-8/6-15	68	80	89	93	91	85	75	72
125-6/3-20	71	79	91	95	93	88	79	75	140-8/9-4	62	73	84	89	87	83	73	68
125-6/3-24	71	79	91	95	93	88	79	75	140-8/9-5,5	62	73	84	89	87	83	73	68
125-8/3-9	50	56	68	78	78	74	66	62	140-8/9-7,5	64	75	86	91	89	85	75	70
125-8/3-15	51	57	69	79	79	75	67	63	140-8/9-10	65	76	87	92	90	86	76	71
125-8/3-20	53	59	71	81	81	77	69	65	140-8/9-15	66	77	88	93	91	87	77	72
125-8/3-27	53	59	71	81	81	77	69	65	140-8/9-20	69	80	91	96	94	90	80	75
125-8/3-37	54	60	72	82	82	78	70	66	160-6/3-10	69	79	87	92	91	90	77	72
125-8/3-40	54	60	72	82	82	78	70	66	160-6/3-15	71	81	89	94	93	92	79	74
125-6/3-4	65	73	85	89	87	82	73	69	160-6/3-20	72	82	90	95	94	93	80	75
125-12/3-4	50	58	70	74	72	67	58	54	160-6/3-25	73	83	91	96	95	94	81	76
125-12/3-5,5	51	59	71	75	73	68	59	55	160-6/3-30	75	85	93	98	97	96	83	78
125-12/3-7,5	52	60	72	76	74	69	60	56	160-6/6-15	69	84	93	95	92	86	78	74
125-12/3-10	54	62	74	78	76	71	62	58	160-6/6-20	70	85	94	96	93	87	79	75
125-12/3-15	55	63	75	79	77	72	63	59	160-6/6-25	71	86	95	97	94	88	80	76
125-12/3-24	56	64	76	80	78	73	64	60	160-6/6-30	72	87	96	98	95	89	81	77
125-4/6-20	67	75	91	98	100	95	89	85	160-6/6-40	73	88	97	99	96	90	82	78
125-4/6-22	67	75	91	98	100	95	89	85	160-6/6-50	75	90	99	101	98	92	84	80
125-4/6-25	68	76	92	99	101	96	90	86	160-6/9-15	67	85	94	93	92	88	79	74
125-4/6-27	68	76	92	99	101	96	90	86	160-6/9-20	68	86	95	94	93	89	80	75
125-4/6-30	68	76	92	99	101	96	90	86	160-6/9-25	69	87	96	95	94	90	81	76
125-4/6-37	68	76	92	99	101	96	90	86	160-6/9-30	70	88	97	96	95	91	82	77
125-4/6-40	70	78	94	101	103	98	92	88	160-6/9-40	71	89	98	97	96	92	83	78
125-4/6-50	71	79	95	102	104	99	93	89	160-6/9-50	72	90	99	98	97	93	84	79
125-6/6-5,5	60	69	82	85	86	83	72	68	160-6/9-60	73	91	100	99	98	94	85	80
125-6/6-7,5	60	69	82	85	86	83	72	68	160-6/9-75	74	92	101	100	99	95	86	81
125-6/6-10	62	71	84	87	88	85	74	70	160-8/3-4	63	73	81	86	85	84	71	66
125-6/6-15	64	73	86	89	90	87	76	72	160-8/3-5,5	65	75	83	88	87	86	73	68
125-6/6-20	65	74	87	90	91	88	77	73	160-8/3-7,5	66	76	84	89	88	87	74	69
125-6/6-24	65	74	87	90	91	88	77	73	160-8/3-10	67	77	85	90	89	88	75	70
125-8/6-20	46	54	70	77	79	74	68	64	160-8/3-15	69	79	87	92	91	90	77	72
125-8/6-22	47	55	71	78	80	75	69	65	160-8/6-5,5	61	76	85	87	84	78	70	66
125-8/6-27	47	55	71	78	80	75	69	65	160-8/6-7,5	63	78	87	89	86	80	72	68
125-8/6-37	48	56	72	79	81	76	70	66	160-8/6-10	64	79	88	90	87	81	73	69
125-8/6-40	49	57	73	80	82	77	71	67	160-8/6-15	66	81	90	92	89	83	75	71
125-12/6-5,5	45	54	67	70	71	68	57	53	160-8/6-20	67	82	91	93	90	84	76	72
125-12/6-7,5	45	54	67	70	71	68	57	53	160-8/6-25	68	83	92	94	91	85	77	73
125-12/6-10	47	56	69	72	73	70	59	55	160-8/9-7,5	61	79	88	87	86	82	73	68
125-12/6-15	49	58	71	74	75	72	61	57	160-8/9-10	62	80	89	88	87	83	74	69
125-12/6-24	50	59	72	75	76	73	62	58	160-8/9-15	64	82	91	90	89	85	76	71
125-4/9-22	66	74	91	97	98	93	88	84	160-8/9-20	65	83	92	91	90	86	77	72
125-4/9-25	66	74	91	97	98	93	88	84	160-8/9-25	66	84	93					

Dimensions in mm

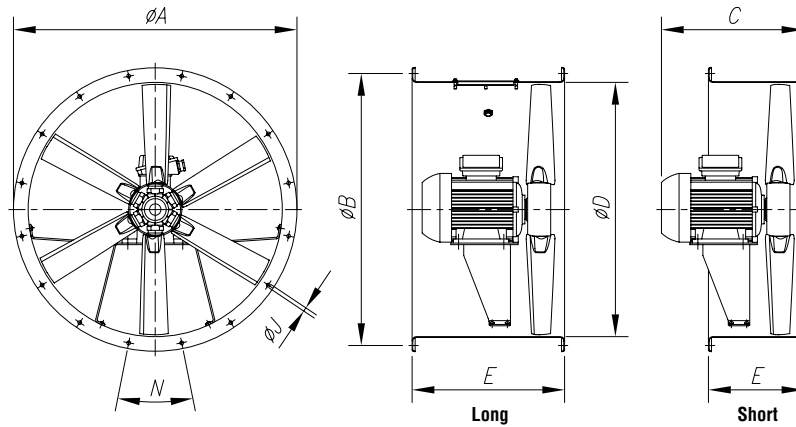

C (consult motor size according to power)

Model	ØA	ØB	80	90S	90L	100	112	132S	132M	160M	160L	180M	180L	200L	225	250	280	ØD	Long	Short	ØJ	N
THT-40	490	450	348	364	389	-	-	-	-	-	-	-	-	-	-	-	-	410	400	250	12	8x45'
THT-45	540	500	348	364	389	-	-	-	-	-	-	-	-	-	-	-	-	460	400	250	12	8x45'
THT-50	600	560	339	364	389	-	-	-	-	-	-	-	-	-	-	-	-	514	400	250	12	12x30'
THT-50	600	560	-	-	-	419	438	-	-	-	-	-	-	-	-	-	-	514	500	250	12	12x30'
THT-56	660	620	275	364	389	-	-	-	-	-	-	-	-	-	-	-	-	560	400	250	12	12x30'
THT-56	660	620	-	-	-	416	432	480	518	-	-	-	-	-	-	-	-	560	500	250	12	12x30'
THT-56	660	620	-	-	-	-	-	-	620	-	-	-	-	-	-	-	-	560	650	250	12	12x30'
THT-63	730	690	339	359	389	-	-	-	-	-	-	-	-	-	-	-	-	640	400	250	12	12x30'
THT-63	730	690	-	-	-	420	437	-	-	-	-	-	-	-	-	-	-	640	500	250	12	12x30'
THT-63	730	690	-	-	-	-	-	539	577	-	-	-	-	-	-	-	-	640	650	250	12	12x30'
THT-63	730	690	-	-	-	-	-	-	-	630	674	-	-	-	-	-	-	640	650	350	12	12x30'
THT-71	810	770	366	379	404	-	-	-	-	-	-	-	-	-	-	-	-	710	430	300	12	16x22'30"
THT-71	810	770	-	-	-	438	433	-	-	-	-	-	-	-	-	-	-	710	500	300	12	16x22'30"
THT-80	900	860	-	-	422	456	472	-	-	-	-	-	-	-	-	-	-	800	500	300	12	16x22'30"
THT-80	900	860	-	-	-	-	-	515	-	-	-	-	-	-	-	-	-	800	600	300	12	16x22'30"
THT-90	1015	970	-	-	-	466	482	525	565	-	-	-	-	-	-	-	-	900	600	350	15	16x22'30"
THT-100	1115	1070	-	-	-	-	482	525	565	-	-	-	-	-	-	-	-	1000	600	350	15	16x22'30"
THT-100	1115	1070	-	-	-	-	-	-	-	695	695	-	-	-	-	-	-	1000	700	450	15	16x22'30"
THT-125	1365	1320	-	-	-	-	-	561	601	-	-	-	-	-	-	-	-	1250	700	500	15	20x18'
THT-125	1365	1320	-	-	-	-	-	-	-	695	695	-	-	-	-	-	-	1250	700	500	15	20x18'
THT-125	1365	1320	-	-	-	-	-	-	-	-	-	740	740	860	-	-	-	1250	900	500	15	20x18'
THT-125	1365	1320	-	-	-	-	-	-	-	-	-	-	-	-	907	-	-	1250	1000	500	15	20x18'
THT-125	1365	1320	-	-	-	-	-	-	-	-	-	-	-	-	-	987	-	1250	1000	600	15	20x18'
THT-125	1365	1320	-	-	-	-	-	-	-	-	-	-	-	-	-	-	1077	1250	1200	600	15	20x18'
THT-140	1515	1470	-	-	-	-	-	-	570	-	-	-	-	-	-	-	-	1400	650	400	15	20x18'
THT-140	1515	1470	-	-	-	-	-	-	-	-	700	-	-	-	-	-	-	1400	700	450	15	20x18'
THT-140	1515	1470	-	-	-	-	-	-	-	-	-	765	-	-	-	-	-	1400	900	550	15	20x18'
THT-140	1515	1470	-	-	-	-	-	-	-	-	-	-	825	-	-	-	-	1400	900	550	15	20x18'
THT-140	1515	1470	-	-	-	-	-	-	-	-	-	-	-	910	-	-	-	1400	1000	550	15	20x18'
THT-140	1515	1470	-	-	-	-	-	-	-	-	-	-	-	-	985	-	-	1400	1000	600	15	20x18'
THT-160	1735	1680	-	-	-	-	-	-	570	-	-	-	-	-	-	-	-	1600	650	400	19	24x15'
THT-160	1735	1680	-	-	-	-	-	-	-	-	700	-	-	-	-	-	-	1600	700	450	19	24x15'
THT-160	1735	1680	-	-	-	-	-	-	-	-	-	765	-	-	-	-	-	1600	900	550	19	24x15'
THT-160	1735	1680	-	-	-	-	-	-	-	-	-	-	825	-	-	-	-	1600	1000	550	19	24x15'
THT-160	1735	1680	-	-	-	-	-	-	-	-	-	-	-	910	-	-	-	1600	1000	550	19	24x15'
THT-160	1735	1680	-	-	-	-	-	-	-	-	-	-	-	-	985	-	-	1600	1000	600	19	24x15'
THT-160	1735	1680	-	-	-	-	-	-	-	-	-	-	-	-	-	1190	-	1600	1000	700	19	24x15'

Motor build sizes depending on power (one-speed)

	CV																			
	0,75	1	1,5	2	3	4	5,5	7,5	10	12	15	20	22	25	30	40	50	60	75	100
2T (3000 r/min)	80	80	80	90S	90L	100LB	112M	132S	132S	132MA	160M	160M	160L	180M	180L	200L	225S/M	225S/M	250S/M	280S/M
4T (1500 r/min)	90S	90S	90S	90L	100LA	100LB	112M	132S	132M	-	160M	160L	-	180M	180L	200L	225S/M	225S/M	250S/M	280S/M
6T (1000 r/min)	90S	90S	90L	100L	112M	132S	132MA	132MB	160M	-	160L	180L	-	200MLA	200MLB	225SMB	250S/M	280S/M	280S/M	-
8T (750 r/min)	90L	100LA	100L	112M	132S	132M	160MA	160M	160L	-	180L	200MLA	-	225SMA	225SMB	250SMA	280S/M	280S/M	-	-

Motor build sizes depending on power (two-speed)

	CV																					
	0,75	1	1,5	2	3	4	5,5	6	7,5	8	10	12	15	18	20	22	24	27	37	38	40	
2/4(3000/1500 r/min)	-	-	90S	90S	90L	100L	-	112M	-	-	132M	-	160MA	-	160M	-	160L	-	-	-	-	
4/8(1500/750 r/min)	-	-	90S	100L	100LA	100LC	132S	-	132S	132S	-	132M	-	160M	-	160L	180M	180M	180L	200MLA	200L	225S/M
6/12(1000/500 r/min)	90L	100L	100LB	112M	112M	132MC	160M	160M	160LB	160LB	-	160LB	-	200MLC	160L	200M	-	250SMB	225S/M	-	225S/M	-

Characteristic curves

See characteristic curves on page 33.

# CJTHT/PLUS

**400°C/2h, 300°C/1h and 200°C/2h axial extraction units with built-in noise reducer**



Extraction units with soundproofed box to work inside fire danger zones at 400°C/2h and noise reducer, with built-in central core.

**Fan:**

- Galvanised sheet steel structure with thermal insulation and soundproofing.
- Turnable cast aluminium impellers.
- Noise reducer with sound-absorbing material, especially tested to reduce noise considerably. Units suitable for working in both horizontal and vertical positions. Approval according to Standard EN-12101-3-2002, certificate no.: 0370-CPD-0312
- Airflow direction from motor to impeller



Highly-efficient built-in noise reducer.

**Motor:**

- Class H motors, ongoing use S1 and emergency use S2, with ball bearings, IP55 protection, and one- or two- speed depending on the model.
- Three-phase 230/400V.-50Hz. (up to 4CV.) and 400/690V.-50Hz. (power over 4CV.)
- Max. temperature of air for transport: S1 Service -20°C+ 40°C for ongoing use, S2 Service 200°C/2h, 300°C/2h, 400°C/2h

**Finish:**

- Anticorrosive galvanized sheet steel.

**On request:**

- 100% reversible impellers.

**Order code**

**CJTHT/PLUS — 56 — 4T — 2 — F-400**

CJTHT/PLUS: 400°C/2h, 300°C/1h y 200°C/2h axial extraction units with built-in noise reducer

Impeller diameter in cm.

Number of motor poles

- 2=2900 r/min. 50 Hz
- 4=1400 r/min. 50 Hz
- 6=900 r/min. 50 Hz
- 8=750 r/min. 50 Hz
- 12=500 r/min. 50 Hz

T=Three-phase

Power motor (c.v.)

F-200 Officially approved 200°C/2h  
F-300 Officially approved 300°C/1h  
F-400 Officially approved 400°C/2h

**Technical characteristics**

Model	Speed (r/min)	Maximum admissible current (A)			Power installed (kW)	Airflow maximum (m³/h)	Sound pressure level dB(A)	Approx. weight (Kg)
		230V	400V	690V				
CJTHT-40-2/4T-1,5/PLUS	2920/1460		2,90/2,10		1,10/0,25	7050/3500	71/56	53
CJTHT-40-2/4T-2/PLUS	2940/1460		4,40/1,40		1,50/0,37	8450/4200	72/57	54
CJTHT-40-4T-0,75/PLUS	1420	2,90	1,70		0,55	4850	59	47
CJTHT-40-6T-0,75/PLUS	930	3,30	1,90		0,55	3150	49	52
CJTHT-40-6/12T-0,75/PLUS	940/440		2,10/0,90		0,55/0,09	3150/1450	49/34	56
CJTHT-45-2/4T-2/PLUS	2940/1460		5,70/1,80		1,50/0,37	10050/5050	73/58	56
CJTHT-45-2/4T-3/PLUS	2930/1450		4,40/1,40		2,20/0,60	11900/5950	75/60	58
CJTHT-45-4T-0,75/PLUS	1420	2,90	1,70		0,55	7650	63	49
CJTHT-45-6T-0,75/PLUS	930	3,30	1,90		0,55	5050	51	53
CJTHT-45-6/12T-0,75/PLUS	940/440		2,10/0,90		0,55/0,09	5050/2350	51/36	58
CJTHT-50-2/4T-4/PLUS	2920/1440		6,70/2,00		3,00/0,80	13850/6950	77/60	65

## Technical characteristics

Model	Speed (r/min)	Maximum admissible current (A)			Power installed (kW)	Airflow maximum (m³/h)	Sound pressure level dB(A)	Approx. weight (Kg)
		230V	400V	690V				
CJTHT-50-2/4T-6/PLUS	2930/1450		10,00/3,20		4,50/1,30	16750/8400	78/63	81
CJTHT-50-4T-1/PLUS	1420	3,70	2,10		0,75	9750	64	51
CJTHT-50-6T-0,75/PLUS	930	3,30	1,90		0,55	7900	53	55
CJTHT-50-6/12T-0,75/PLUS	940/440		2,10/0,90		0,55/0,09	7900/3650	53/38	59
CJTHT-56-2/4T-6/PLUS	2930/1450		10,00/3,20		4,50/1,30	21250/10650	83/67	90
CJTHT-56-2/4T-12/PLUS	2920/1440		20,70/5,50		9,00/2,50	28200/14100	84/69	153
CJTHT-56-4T-1/PLUS	1420	3,70	2,10		0,75	11850	68	62
CJTHT-56-4T-1,5/PLUS	1420	4,70	2,70		1,10	13550	69	64
CJTHT-56-4/8T-1,5/PLUS	1440/710		2,90/1,40		1,10/0,25	13550/6750	69/52	68
CJTHT-56-4T-2/PLUS	1425	6,60	3,80		1,50	15450	70	68
CJTHT-56-4/8T-2/PLUS	1415/715		3,60/1,50		1,50/0,30	15450/7700	70/53	80
CJTHT-56-6T-0,75/PLUS	930	3,30	1,90		0,55	10900	58	64
CJTHT-56-6/12T-0,75/PLUS	940/440		2,10/0,90		0,55/0,09	10900/5050	58/41	68
CJTHT-63-4T-1/PLUS	1420	3,70	2,10		0,75	15200	68	66
CJTHT-63-4T-1,5/PLUS	1420	4,70	2,70		1,10	17800	69	69
CJTHT-63-4/8T-1,5/PLUS	1440/710		2,90/1,40		1,10/0,25	17800/8850	69/52	72
CJTHT-63-4T-2/PLUS	1425	6,60	3,80		1,50	20100	70	72
CJTHT-63-4/8T-2/PLUS	1415/715		3,60/1,50		1,50/0,30	20100/9950	70/53	84
CJTHT-63-4T-3/PLUS	1435	9,20	5,30		2,2	22300	72	78
CJTHT-63-4/8T-3/PLUS	1415/715		5,20/1,90		2,2/0,45	22300/11050	72/54	90
CJTHT-63-4T-4/PLUS	1430	11,40	6,60		3,00	24350	73	87
CJTHT-63-4/8T-4/PLUS	1425/710		6,80/2,20		3,00/0,60	24350/12100	73/55	101
CJTHT-63-6T-0,75/PLUS	930	3,30	1,90		0,55	14100	61	68
CJTHT-63-6/12T-0,75/PLUS	940/440		2,10/0,90		0,55/0,09	14100/6550	61/44	72
CJTHT-63-6T-1/PLUS	940	4,40	2,60		0,75	15950	62	72
CJTHT-63-6/12T-1/PLUS	935/430		2,50/1,03		0,75/0,15	15950/7400	62/45	78
CJTHT-71-4T-1,5/PLUS	1420	4,70	2,70		1,10	19550	74	85
CJTHT-71-4/8T-1,5/PLUS	1440/710		2,90/1,40		1,10/0,25	19550/9700	74/59	89
CJTHT-71-4T-2/PLUS	1425	6,60	3,80		1,50	22200	75	89
CJTHT-71-4/8T-2/PLUS	1415/715		3,60/1,50		1,50/0,30	22200/11050	75/60	101
CJTHT-71-4T-3/PLUS	1435	9,20	5,30		2,20	25850	76	95
CJTHT-71-4/8T-3/PLUS	1415/715		5,20/1,90		2,20/0,45	25850/12850	76/62	107
CJTHT-71-4T-4/PLUS	1430	11,40	6,60		3,00	29600	77	104
CJTHT-71-4/8T-4/PLUS	1425/710		6,80/2,20		3,00/0,60	29600/14700	77/63	118
CJTHT-71-6T-0,75/PLUS	930	3,30	1,90		0,55	16100	63	85
CJTHT-71-6/12T-0,75/PLUS	940/440		2,10/0,90		0,55/0,09	16100/7450	63/49	89
CJTHT-71-6T-1/PLUS	940	4,40	2,60		0,75	18050	64	88
CJTHT-71-6/12T-1/PLUS	935/430		2,50/1,03		0,75/0,15	18050/8350	64/49	95
CJTHT-71-6T-1,5/PLUS	945	6,40	3,70		1,10	20550	65	94
CJTHT-71-6/12T-1,5/PLUS	940/450		3,30/1,20		1,10/0,18	20550/9500	65/50	102
CJTHT-80-4T-3/PLUS	1435	9,20	5,30		2,20	25550	78	103
CJTHT-80-4/8T-3/PLUS	1415/715		5,20/1,90		2,20/0,45	25550/12700	78/63	115
CJTHT-80-4T-4/PLUS	1430	11,40	6,60		3,00	30400	79	112
CJTHT-80-4/8T-4/PLUS	1425/710		6,80/2,20		3,00/0,60	30400/15100	79/64	125
CJTHT-80-4T-5,5/PLUS	1440		8,40	4,80	4,00	32950	80	118
CJTHT-80-4/8T-5,5/PLUS	1455/725		9,30/3,40		4,00/0,80	32950/16350	80/65	153
CJTHT-80-6T-1,5/PLUS	945	6,40	3,70		1,10	21600	68	102
CJTHT-80-6/12T-1,5/PLUS	940/450		3,30/1,20		1,10/0,18	21600/7750	68/53	110
CJTHT-80-6T-2/PLUS	945	7,40	4,30		1,50	26100	69	111
CJTHT-80-6/12T-2/PLUS	960/470		4,30/1,70		1,50/0,25	26100/12100	69/54	115
CJTHT-80-6T-3/PLUS	950	10,30	5,90		2,20	30000	70	118
CJTHT-80-6/12T-3/PLUS	940/470		5,60/2,20		2,20/0,37	30000/13900	70/55	124
CJTHT-80-8T-0,75/PLUS	700	3,60	2,10		0,55	19050	67	95

## Technical characteristics

Model	Speed (r/min)	Maximum admissible current (A)			Power installed (kW)	Airflow maximum (m³/h)	Sound pressure level dB(A)	Approx. weight (Kg)
		230V	400V	690V				
CJTHT-80-8T-1/PLUS	710	4,80	2,80		0,75	20750	68	102
CJTHT-90-4T-4/PLUS	1430	11,40	6,60		3,00	36150	82	136
CJTHT-90-4/8T-4/PLUS	1425/710		6,80/2,20		3,00/0,60	36150/17950	82/68	149
CJTHT-90-4T-5,5/PLUS	1440		8,40	4,80	4,00	41650	84	142
CJTHT-90-4/8T-5,5/PLUS	1455/725		9,30/3,4		4,00/0,80	41650/20700	84/69	177
CJTHT-90-4T-7,5/PLUS	1460		13,00	7,50	5,50	46350	86	168
CJTHT-90-4/8T-7,5/PLUS	1455/725		12,80/4,60		5,50/1,10	46350/23000	86/72	182
CJTHT-90-4T-10/PLUS	1460		17,70	10,20	7,50	50300	87	179
CJTHT-90-4/8T-9/PLUS	1455/725		15,50/5,50		6,70/1,50	48550/24100	87/73	182
CJTHT-90-6T-2/PLUS	945	7,40	4,30		1,50	28900	74	135
CJTHT-90-6/12T-2/PLUS	960/470		4,30/1,70		1,50/0,25	28900/13400	74/59	139
CJTHT-90-6T-3/PLUS	950	10,30	5,90		2,20	34050	75	142
CJTHT-90-6/12T-3/PLUS	940/470		5,60/2,20		2,20/0,37	34050/15750	75/60	148
CJTHT-90-6T-4/PLUS	970	14,60	8,40		3,00	39050	76	166
CJTHT-90-6/12T-4/PLUS	970/475		8,90/3,50		3,00/0,55	39050/18100	76/61	168
CJTHT-90-8T-1/PLUS	710	4,80	2,80		0,75	23000	68	126
CJTHT-90-8T-2/PLUS	700	9,00	5,20		1,50	30950	69	142
CJTHT-90-8T-3/PLUS	710	11,40	6,60		2,20	30950	70	158
CJTHT-100-4T-7,5/PLUS	1460		13,00	7,50	5,50	50950	88	176
CJTHT-100-4/8T-7,5/PLUS	1455/725		12,80/4,60		5,50/1,10	50950/25300	88/73	190
CJTHT-100-4T-10/PLUS	1460		17,70	10,20	7,50	57650	89	187
CJTHT-100-4/8T-9/PLUS	1455/725		15,50/5,50		6,70/1,50	54900/27250	89/74	190
CJTHT-100-4T-15/PLUS	1460		22,00	12,70	11,00	66500	90	231
CJTHT-100-4/8T-15/PLUS	1470/725		23,20/8,70		11,00/2,80	66500/33000	90/75	231
CJTHT-100-4T-20/PLUS	1460		29,00	16,70	15,00	76450	91	246
CJTHT-100-4/8T-20/PLUS	1470/725		31,70/11,80		15,00/3,80	76450/37950	91/76	246
CJTHT-100-6T-3/PLUS	950	10,30	5,90		2,20	37750	79	150
CJTHT-100-6/12T-3/PLUS	940/470		5,60/2,20		2,20/0,37	37750/17500	79/64	156
CJTHT-100-6T-4/PLUS	970	14,60	8,40		3,00	43550	80	175
CJTHT-100-6/12T-4/PLUS	970/475		8,90/3,50		3,00/0,55	43550/20200	80/65	176
CJTHT-100-6T-5,5/PLUS	970		11,00	6,40	4,00	47950	81	187
CJTHT-100-6/12T-5,5/PLUS	970/480		11,30/4,20		4,00/0,65	47950/22200	81/66	187
CJTHT-100-8T-2/PLUS	700	9,00	5,20		1,50	34700	74	150
CJTHT-100-8T-3/PLUS	710	11,40	6,60		2,20	40600	74	167
CJTHT-100-8T-4/PLUS	710	15,60	9,00		3,00	40600	75	187

## Acoustic features

The specified values are determined according to free field measurements of pressure and sound levels in dB(A) at an equivalent distance of twice the fan's span plus the impeller's diameter, with a minimum of 1.5 m.

Sound power Lw(A) spectrum in dB(A) via frequency band in Hz.

Model	63	125	250	500	1000	2000	4000	8000	Model	63	125	250	500	1000	2000	4000	8000
40-2-1,5	43	64	71	76	79	75	68	57	50-6	28	48	56	61	63	60	53	42
40-2-2	44	65	72	77	80	76	69	58	50-12	13	33	41	46	48	45	38	27
40-4-0,75	31	52	59	64	67	63	56	45	56-2-6	58	78	86	91	93	90	83	72
40-4-1,5	28	49	56	61	64	60	53	42	56-2-12	59	79	87	92	94	91	84	73
40-4-2	29	50	57	62	65	61	54	43	56-4-1	43	63	71	76	78	75	68	57
40-6	21	42	49	54	57	53	46	35	56-4-1,5	44	64	72	77	79	76	69	58
40-12	6	27	34	39	42	38	31	20	56-4-2	45	65	73	78	80	77	70	59
45-2-2	45	66	73	78	81	77	70	59	56-4-6	42	62	70	75	77	74	67	56
45-2-3	47	68	75	80	83	79	72	61	56-4-12	44	64	72	77	79	76	69	58
45-4-0,75	35	56	63	68	71	67	60	49	56-6	33	53	61	66	68	65	58	47
45-4-2	30	51	58	63	66	62	55	44	56-8-1,5	27	47	55	60	62	59	52	41
45-4-3	32	53	60	65	68	64	57	46	56-8-2	28	48	56	61	63	60	53	42
45-6	23	44	51	56	59	55	48	37	56-12	16	36	44	49	51	48	41	30
45-12	8	29	36	41	44	40	33	22	63-4-1	45	65	73	78	80	77	70	59
50-2-4	52	72	80	85	87	84	77	66	63-4-1,5	44	64	72	77	79	76	69	60
50-2-6	53	73	81	86	88	85	78	67	63-4-2	47	64	72	77	79	76	69	61
50-4-1	39	59	67	72	74	71	64	53	63-4-3	49	67	75	80	82	79	74	63
50-4-4	35	55	63	68	70	67	60	49	63-4-4	50	68	76	81	83	80	75	64
50-4-6	38	58	66	71	73	70	63	52	63-6-0,75	38	56	64	69	71	68	61	52

## Acoustic features

Sound power Lw(A) spectrum in dB(A) via frequency band in Hz.

63-6-1	39	58	66	71	73	70	63	53	90-4-5,5	56	77	84	89	92	88	81	70
63-8-1,5	27	47	55	60	62	59	52	43	90-4-7,5	55	76	83	88	91	87	80	69
63-8-2	30	47	55	60	62	59	52	44	90-4-9	54	75	82	87	90	86	79	68
63-8-3	31	49	57	62	64	61	56	45	90-4-10	54	75	82	87	90	86	79	68
63-8-4	32	50	58	63	65	62	57	46	90-6-2	46	67	74	79	82	78	71	60
63-12-0,75	21	37	45	50	52	49	42	31	90-6-3	53	67	74	79	82	78	71	60
63-12-1	22	39	47	52	54	51	44	36	90-6-4	54	69	76	81	84	80	73	62
71-4-1,5	51	71	79	84	86	83	76	65	90-8-1	39	60	67	72	75	71	64	53
71-4-2	50	70	78	83	85	82	75	66	90-8-2	47	62	69	74	77	73	66	55
71-4-3	53	68	76	81	83	80	73	67	90-8-3	48	62	69	74	77	73	66	55
71-4-4	54	69	77	82	84	81	74	68	90-8-4	43	64	71	76	79	75	68	60
71-6-0,75	40	60	68	71	73	70	63	52	90-8-5,5	41	62	69	74	77	73	66	55
71-6-1	41	61	69	71	73	70	63	52	90-8-7,5	40	61	68	73	76	72	65	54
71-6-1,5	42	62	67	72	74	71	64	53	90-8-9	40	61	68	73	76	72	65	54
71-8-1,5	36	55	63	68	70	67	61	50	90-12-2	29	50	57	62	65	61	54	43
71-8-2	35	55	63	68	70	67	60	51	90-12-3	38	50	57	62	65	61	54	43
71-8-3	39	54	62	67	69	66	59	53	90-12-4	39	52	59	64	67	63	56	45
71-8-4	40	55	63	68	70	67	60	54	100-4-7,5	61	81	89	94	96	93	86	75
71-12-0,75	26	42	50	55	57	54	47	36	100-4-9	60	80	88	93	95	92	85	74
71-12-1	26	42	50	55	57	54	47	36	100-4-10	59	79	87	92	94	91	84	73
71-12-1,5	27	42	50	55	57	54	47	36	100-4-15	58	78	86	91	93	90	83	72
80-4-3	55	74	82	88	89	86	80	69	100-4-20	60	80	88	93	95	92	85	74
80-4-4	53	73	81	86	88	85	78	70	100-6-3	59	70	78	83	85	82	75	64
80-4-5,5	53	73	81	86	88	85	78	71	100-6-4	60	68	76	81	83	80	73	62
80-6-1,5	45	62	70	75	77	74	67	56	100-6-5,5	61	70	78	83	85	82	75	64
80-6-2	46	63	71	76	78	75	68	57	100-8-2	54	64	72	77	79	76	69	58
80-6-3	47	64	72	77	79	76	69	58	100-8-3	54	66	74	79	81	78	71	60
80-8-0,75	44	57	65	70	72	69	62	51	100-8-4	55	66	74	79	81	78	71	60
80-8-1	45	58	66	71	73	70	63	52	100-8-7,5	46	66	74	79	81	78	71	60
80-8-3	40	59	67	73	74	71	65	54	100-8-9	45	65	73	78	80	77	70	59
80-8-4	38	58	66	71	73	70	63	55	100-8-15	43	63	71	76	78	75	68	57
80-8-5,5	37	57	65	70	72	69	62	56	100-8-20	44	64	72	77	79	76	69	58
80-12-1,5	30	45	53	58	60	57	50	39	100-12-3	44	53	61	66	68	65	58	47
80-12-2	31	46	54	59	61	58	51	40	100-12-4	45	52	60	65	67	64	57	46
80-12-3	32	47	55	60	62	59	52	41	100-12-5,5	46	53	61	66	68	65	58	47
90-4-4	57	78	85	90	93	89	82	74									

## Dimensions in mm

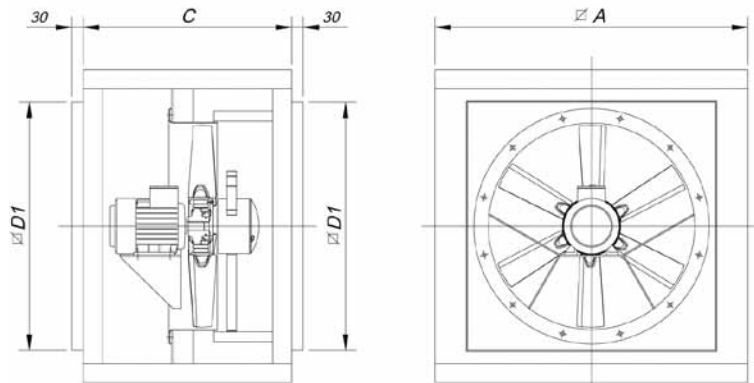

Model	∅A	C	∅D1
CJTHT/PLUS-40/45/50	700	550	565
CJTHT/PLUS-56/63	825	550	690
CJTHT/PLUS-71/80	1000	650	850
CJTHT/PLUS-90/100	1200	750	1050

## Characteristic curves

See characteristic curves on page 33.

## Accessories

See accessories section



# CJTHT

**CJTHT: 400°C/2h, 300°C/1h and 200°C/2h axial extraction units with soundproofed box**  
**CJTHT/ATEX: 400°C/2h, 300°C/1h and 200°C/2h axial extraction units with ATEX certification**



Detail CJTHT/ATEX

Extraction units to work inside fire danger zones at 400°C/2h, with soundproofed box.

**Fan:**

- Galvanised sheet steel structure with thermal insulation and soundproofing.
- Turnable impellers cast aluminium.
- Units suitable for working in both horizontal and vertical positions.
- Approval according to Standard EN-12101-3-2002, certificate no.: 0370-CPD-0312
- CJTHT/ATEX: with ATEX certification, category 3 Ex II3G. In accordance with Spanish Low Voltage Regulation ITC 29 ATEX for Zone 2 rated car parks.



**Motor:**

- Class H motors, ongoing use S1 and emergency use S2, with ball bearings, IP55 protection, and one- or two- speed depending on the model.
- Three-phase 230/400V.-50Hz. (up to 4CV.) and 400/690V.-50Hz. (power over 4CV.)
- Max. temperature of air for transport: S1 Service -20°C+ 40°C for ongoing use, S2 Service 200°C/2h, 300°C/2h, 400°C/2h

**Finish:**

- Anticorrosive galvanized sheet steel.

**On request:**

- 100% reversible impellers.

## Order code

From size 40 to size 100

**CJTHT — 56 — 4T — 2 — F-400**

CJTHT: 400°C/2h, 300°C/1h and 200°C/2h axial extraction units with soundproofed box

CJTHT/ATEX: 400°C/2h, 300°C/1h and 200°C/2h axial extraction units with ATEX certification

Impeller diameter in cm.

Number of motor poles  
 2=2900 r/min. 50 Hz  
 4=1400 r/min. 50 Hz  
 6=900 r/min. 50 Hz  
 8=750 r/min. 50 Hz  
 12=500 r/min. 50 Hz

T=Three-phase

Power motor (c.v.)

F-200 Officially approved 200°C/2h  
 F-300 Officially approved 300°C/1h  
 F-400 Officially approved 400°C/2h  
 CAT3: With ATEX certification, Category 3 Ex II3G.

Size 125

**CJTHT — 125 — 4T — 15 — 9-10 — F-400**

CJTHT: 400°C/2h, 300°C/1h and 200°C/2h axial extraction units with soundproofed box

Impeller diameter in cm.

Number of motor poles  
 2=2900 r/min. 50 Hz  
 4=1400 r/min. 50 Hz  
 6=900 r/min. 50 Hz  
 8=750 r/min. 50 Hz  
 12=500 r/min. 50 Hz

T=Three-phase

Power motor (c.v.)

Number of blades  
 3 blades  
 6 blades  
 9 blades

Angle of inclination of the blades

F-200 Officially approved 200°C/2h  
 F-300 Officially approved 300°C/1h  
 F-400 Officially approved 400°C/2h  
 CAT3: With ATEX certification, Category 3 Ex II3G.

## Technical characteristics

Model	Speed (r/min)	Maximum admissible current (A)			Power installed (kW)	Airflow maximum (m³/h)	Sound pressure level dB(A)	Approx. weight (Kg)
		230V	400V	690V				
CJTHT-40-2/4T-1,5	2920/1460		2,90/2,10		1,10/0,25	7050/3500	73/58	50
CJTHT-40-2/4T-2	2940/1460		4,40/1,40		1,50/0,37	8450/4200	74/59	51
CJTHT-40-4T-0,75	1420	2,90	1,70		0,55	4850	61	41
CJTHT-40-6T-0,75	930	3,30	1,90		0,55	3150	51	49
CJTHT-40-6/12T-0,75	940/440		2,10/0,90		0,55/0,09	3150/1450	51/36	53
CJTHT-45-2/4T-2	2940/1460		5,70/1,80		1,50/0,37	10050/5050	75/60	53
CJTHT-45-2/4T-3	2930/1450		4,40/1,40		2,20/0,60	11900/5950	77/62	55
CJTHT-45-4T-0,75	1420	2,90	1,70		0,55	7650	65	43
CJTHT-45-6T-0,75	930	3,30	1,90		0,55	5050	53	51
CJTHT-45-6/12T-0,75	940/440		2,10/0,90		0,55/0,09	5050/2350	53/38	55
CJTHT-50-2/4T-4	2920/1440		6,70/2,00		3,00/0,80	13850/6950	79/64	62
CJTHT-50-2/4T-6	2930/1450		10,00/3,20		4,50/1,30	16750/8400	80/65	78
CJTHT-50-4T-1	1420	3,70	2,10		0,75	9750	66	50
CJTHT-50-6T-0,75	930	3,30	1,90		0,55	7900	55	52
CJTHT-50-6/12T-0,75	940/440		2,10/0,90		0,55/0,09	7900/3650	55/40	56
CJTHT-56-2/4T-6	2930/1450		10,00/3,20		4,50/1,30	21250/10650	85/69	87
CJTHT-56-2/4T-12	2920/1440		20,70/5,50		9,00/2,50	28200/14100	86/71	153
CJTHT-56-4T-1	1420	3,70	2,10		0,75	11850	70	59
CJTHT-56-4T-1,5	1420	4,70	2,70		1,10	13550	71	61
CJTHT-56-4/8T-1,5	1440/710		2,90/1,40		1,10/0,25	13550/6750	71/56	65
CJTHT-56-4T-2	1425	6,60	3,80		1,50	15450	72	63
CJTHT-56-4/8T-2	1415/715		3,60/1,50		1,50/0,30	15450/7700	72/57	69
CJTHT-56-6T-0,75	930	3,30	1,90		0,55	10900	60	61
CJTHT-56-6/12T-0,75	940/440		2,10/0,90		0,55/0,09	10900/5050	60/45	65
CJTHT-63-4T-1	1420	3,70	2,10		0,75	15200	70	63
CJTHT-63-4T-1,5	1420	4,70	2,70		1,10	17800	71	66
CJTHT-63-4/8T-1,5	1440/710		2,90/1,40		1,10/0,25	17800/8850	71/56	69
CJTHT-63-4T-2	1425	6,60	3,80		1,50	20100	72	67
CJTHT-63-4/8T-2	1415/715		3,60/1,50		1,50/0,30	20100/9950	72/57	74
CJTHT-63-4T-3	1435	9,20	5,30		2,20	22300	73	73
CJTHT-63-4/8T-3	1415/715		5,20/1,90		2,20/0,45	22300/11050	73/58	87
CJTHT-63-4T-4	1430	11,40	6,60		3,00	24350	74	78
CJTHT-63-4/8T-4	1425/710		6,80/2,20		3,00/0,60	24350/12100	74/59	91
CJTHT-63-6T-0,75	930	3,30	1,90		0,55	14100	63	66
CJTHT-63-6/12T-0,75	940/440		2,10/0,90		0,55/0,09	14100/6550	63/48	69
CJTHT-63-6T-1	940	4,40	2,60		0,75	15950	64	67
CJTHT-63-6/12T-1	935/430		2,50/1,03		0,75/0,15	15950/7400	64/49	71
CJTHT-71-4T-1,5	1420	4,70	2,70		1,10	19550	75	82
CJTHT-71-4/8T-1,5	1440/710		2,90/1,40		1,10/0,25	19550/9700	75/60	86
CJTHT-71-4T-2	1425	6,60	3,80		1,50	22200	76	84
CJTHT-71-4/8T-2	1415/715		3,60/1,50		1,50/0,30	22200/11050	76/61	91
CJTHT-71-4T-3	1435	9,20	5,30		2,20	25850	78	90
CJTHT-71-4/8T-3	1415/715		5,20/1,90		2,20/0,45	25850/12850	78/63	103
CJTHT-71-4T-4	1430	11,40	6,60		3,00	29600	79	95
CJTHT-71-4/8T-4	1425/710		6,80/2,20		3,00/0,60	29600/14700	79/64	108
CJTHT-71-6T-0,75	930	3,30	1,90		0,55	16100	65	82
CJTHT-71-6/12T-0,75	940/440		2,10/0,90		0,55/0,09	16100/7450	65/50	86
CJTHT-71-6T-1	940	4,40	2,60		0,75	18050	66	84
CJTHT-71-6/12T-1	935/430		2,50/1,03		0,75/0,15	18050/8350	66/51	87
CJTHT-71-6T-1,5	945	6,40	3,70		1,10	20550	67	86
CJTHT-71-6/12T-1,5	940/450		3,30/1,20		1,10/0,18	20550/9500	67/52	97
CJTHT-80-4T-3	1435	9,20	5,30		2,20	25550	79	98
CJTHT-80-4/8T-3	1415/715		5,20/1,90		2,20/0,45	25550/12700	79/64	111

## Technical characteristics

Model	Speed (r/min)	Maximum admissible current (A)			Power installed (kW)	Airflow maximum (m³/h)	Sound pressure level dB(A)	Approx. weight (Kg)
		230V	400V	690V				
CJTHT-80-4T-4	1430	11,40	6,60		3,00	30400	80	103
CJTHT-80-4/8T-4	1425/710		6,80/2,20		3,00/0,60	30400/15100	80/65	115
CJTHT-80-4T-5,5	1440		8,40	4,80	4,00	32950	81	113
CJTHT-80-4/8T-5,5	1455/725		9,30/3,40		4,00/0,80	32950/16350	81/66	147
CJTHT-80-6T-1,5	945	6,40	3,70		1,10	21600	70	95
CJTHT-80-6/12T-1,5	940/450		3,30/1,20		1,10/0,18	21600/7750	70/55	105
CJTHT-80-6T-2	945	7,40	4,30		1,50	26100	71	99
CJTHT-80-6/12T-2	960/470		4,30/1,70		1,50/0,25	26100/12100	71/56	113
CJTHT-80-6T-3	950	10,30	5,90		2,20	30000	72	113
CJTHT-80-6/12T-3	940/470		5,60/2,20		2,20/0,37	30000/13900	72/57	118
CJTHT-80-8T-0,75	700	3,60	2,10		0,55	19050	68	99
CJTHT-80-8T-1	710	4,80	2,80		0,75	20750	69	111
CJTHT-90-4T-4	1430	11,40	6,60		3,00	36150	84	127
CJTHT-90-4/8T-4	1425/710		6,80/2,20		3,00/0,60	36150/17950	84/69	139
CJTHT-90-4T-5,5	1440		8,40	4,80	4,00	41650	86	137
CJTHT-90-4/8T-5,5	1455/725		9,30/3,40		4,00/0,80	41650/20700	86/71	171
CJTHT-90-4T-7,5	1460		13,00	7,50	5,50	46350	88	171
CJTHT-90-4/8T-7,5	1455/725		12,80/4,60		5,50/1,10	46350/23000	88/73	190
CJTHT-90-4T-10	1460		17,70	10,20	7,50	50300	89	208
CJTHT-90-4/8T-9	1455/725		15,50/5,50		6,70/1,50	48550/24100	89/74	198
CJTHT-90-6T-2	945	7,40	4,30		1,50	28900	75	123
CJTHT-90-6/12T-2	960/470		4,30/1,70		1,50/0,25	28900/13400	75/60	137
CJTHT-90-6T-3	950	10,30	5,90		2,20	34050	76	137
CJTHT-90-6/12T-3	940/470		5,60/2,20		2,20/0,37	34050/15750	76/61	142
CJTHT-90-6T-4	970	14,60	8,40		3,00	39050	77	171
CJTHT-90-6/12T-4	970/475		8,90/3,50		3,00/0,55	39050/18100	77/62	171
CJTHT-90-8T-1	710	4,80	2,80		0,75	23000	69	135
CJTHT-90-8T-2	700	9,00	5,20		1,50	30950	71	139
CJTHT-90-8T-3	710	11,40	6,60		2,20	30950	72	171
CJTHT-100-4T-7,5	1460		13,00	7,50	5,50	50950	89	179
CJTHT-100-4/8T-7,5	1455/725		12,80/4,60		5,50/1,10	50950/25300	89/74	198
CJTHT-100-4T-10	1460		17,70	10,20	7,50	57650	90	216
CJTHT-100-4/8T-9	1455/725		15,50/5,50		6,70/1,50	54900/27250	90/75	206
CJTHT-100-4T-15	1460		22,00	12,70	11,00	66500	91	251
CJTHT-100-4/8T-15	1470/725		23,20/8,70		11,00/2,80	66500/33000	91/76	251
CJTHT-100-4T-20	1460		29,00	16,70	15,00	76450	92	258
CJTHT-100-4/8T-20	1470/725		31,70/11,80		15,00/3,80	76450/37950	92/77	258
CJTHT-100-6T-3	950	10,30	5,90		2,20	37750	80	145
CJTHT-100-6/12T-3	940/470		5,60/2,20		2,20/0,37	37750/17500	80/65	150
CJTHT-100-6T-4	970	14,60	8,40		3,00	43550	81	179
CJTHT-100-6/12T-4	970/475		8,90/3,50		3,00/0,55	43550/20200	81/66	179
CJTHT-100-6T-5,5	970		11,00	6,40	4,00	47950	82	187
CJTHT-100-6/12T-5,5	970/480		11,30/4,20		4,00/0,65	47950/22200	82/67	206
CJTHT-100-8T-2	700	9,00	5,20		1,50	34700	75	147
CJTHT-100-8T-3	710	11,40	6,60		2,20	40600	75	179
CJTHT-100-8T-4	710	15,60	9,00		3,00	40600	76	216
CJTHT-125-4T/3-10	1465		14,20	8,20	7,50	58150	85	395
CJTHT-125-4/8T/3-9	1430/725		14,40/4,64		7,20/1,80	58150/28900	85/65	409
CJTHT-125-4T/3-15	1460		21,50	12,40	11,00	77450	86	450
CJTHT-125-4/8T/3-15	1455/725		21,00/7,00		11,00/3,00	77450/38450	86/66	456
CJTHT-125-4T/3-20	1455		29,00	16,70	15,00	91400	88	457
CJTHT-125-4/8T/3-20	1455/725		26,50/8,45		14,00/3,50	91400/45350	88/68	476
CJTHT-125-4T/3-25	1470		34,50	19,90	18,50	104400	88	540

**Technical characteristics**

Model	Speed (r/min)	Maximum admissible current (A)			Power installed (kW)	Airflow maximum (m³/h)	Sound pressure level dB(A)	Approx. weight (Kg)
		230V	400V	690V				
CJTHT-125-4T/3-30	1470		41,70	24,10	22,00	110500	89	545
CJTHT-125-4/8T/3-27	1470/730		38,60/14,10		20,00/5,00	104400/51850	89/68	548
CJTHT-125-4/8T/3-37	1480/735		52,00/18,00		28,00/6,50	120850/60000	90/69	625
CJTHT-125-4T/3-40	1475		54,80	31,60	30,00	129300	90	598
CJTHT-125-4/8T/3-40	1470/730		67,30/21,80		35/8	129300/64200	90/69	638
CJTHT-125-4T/6-20	1455		29,00	16,70	15,00	85150	86	466
CJTHT-125-4/8T/6-20	1455/725		26,50/8,45		14,00/3,50	85150/42300	86/65	485
CJTHT-125-4/8T/6-22	1475/730		33,40/12,70		17,00/4,30	85150/42300	86/66	555
CJTHT-125-4T/6-25	1470		34,50	19,90	18,50	92000	87	549
CJTHT-125-4/8T/6-27	1470/730		38,60/14,10		20,00/5,00	98100/48700	87/66	557
CJTHT-125-4T/6-30	1470		41,70	24,10	22,00	104150	87	554
CJTHT-125-4/8T/6-37	1480/735		52,00/18,00		28,00/6,50	110250/54750	87/67	633
CJTHT-125-4T/6-40	1475		54,80	31,60	30,00	117000	89	606
CJTHT-125-4/8T/6-40	1470/730		67,30/21,80		35,00/8,00	117000/58100	89/68	646
CJTHT-125-4T/6-50	1480		65,40	37,80	37,00	130450	90	734
CJTHT-125-4T/9-25	1470		34,50	19,90	18,50	79750	85	558
CJTHT-125-4/8T/9-22	1475/730		33,40/12,70		17,00/4,30	71150/35300	85/66	564
CJTHT-125-4T/9-30	1470		41,70	24,10	22,00	97000	86	563
CJTHT-125-4/8T/9-27	1470/730		38,60/14,10		20,00/5,00	88350/43900	86/67	566
CJTHT-125-4/8T/9-37	1480/735		52,00/18,00		28,00/6,50	104100/51700	87/67	642
CJTHT-125-4T/9-40	1475		54,80	31,60	30,00	104100	88	615
CJTHT-125-4/8T/9-40	1470/730		67,30/21,80		35,00/8,00	104100/51700	88/68	655
CJTHT-125-4T/9-50	1480		65,40	37,80	37,00	118350	90	743
CJTHT-125-6T/3-4	960		6,82		3,00	50750	77	385
CJTHT-125-6/12T/3-4	960/470		6,39/2,42		2,80/0,70	50750/23500	77/62	401
CJTHT-125-6T/3-5,5	940		8,72	5,00	4,00	59850	78	393
CJTHT-125-6/12T/3-5,5	975/480		8,38/3,57		3,80/1,00	59850/27750	78/63	432
CJTHT-125-6T/3-7,5	960		12,20	7,00	5,50	68400	79	401
CJTHT-125-6/12T/3-7,5	980/485		11,80/8,25		5,00/1,30	68400/31700	79/64	445
CJTHT-125-6T/3-10	970		15,60	9,00	7,50	79150	81	449
CJTHT-125-6/12T/3-10	975/480		16,20/6,84		7,20/1,80	79150/36650	81/66	457
CJTHT-125-6T/3-15	970		23,30	13,50	11,00	89400	82	466
CJTHT-125-6/12T/3-15	975/480		20,60/8,25		11,00/3,00	89400/41400	82/67	557
CJTHT-125-6T/3-20	970		27,40	15,80	15,00	91700	83	533
CJTHT-125-6/12T/3-24	980/485		31,00/10,20		17,00/4,30	91700/42450	83/68	623
CJTHT-125-6T/6-5,5	940		8,72	5,00	4,00	51300	75	402
CJTHT-125-6/12T/6-5,5	975/480		8,38/3,57		3,80/1,00	51300/23750	75/60	441
CJTHT-125-6T/6-7,5	960		12,20	7,00	5,50	64250	75	410
CJTHT-125-6/12T/6-7,5	980/485		11,80/8,25		5,00/1,30	64250/29750	75/60	454
CJTHT-125-6T/6-10	970		15,60	9,00	7,50	72250	77	458
CJTHT-125-6/12T/6-10	975/480		16,20/6,84		7,20/1,80	72250/33450	77/62	466
CJTHT-125-6T/6-15	970		23,30	13,50	11,00	85450	79	475
CJTHT-125-6/12T/6-15	975/480		20,60/8,25		11,00/3,00	85450/39600	79/64	566
CJTHT-125-6T/6-20	970		27,40	15,80	15,00	96750	80	542
CJTHT-125-6/12T/6-24	980/485		31,00/10,20		17,00/4,30	102650/47550	80/65	631
CJTHT-125-6T/9-10	970		15,60	9,00	7,50	68200	76	467
CJTHT-125-6/12T/9-10	975/480		16,20/6,84		7,20/1,80	68200/31600	76/61	475
CJTHT-125-6T/9-15	970		23,30	13,50	11,00	77550	79	484
CJTHT-125-6/12T/9-15	975/480		20,60/8,25		11,00/3,00	77550/35900	79/64	575
CJTHT-125-6T/9-20	970		27,40	15,80	15,00	92950	82	551
CJTHT-125-6/12T/9-24	980/485		31,00/10,20		17,00/4,30	98650/45700	82/67	640

### Acoustic features

The specified values are determined according to free field measurements of pressure and sound levels in dB(A) at an equivalent distance of twice the fan's span plus the impeller's diameter, with a minimum of 1.5 m.

Sound power Lw(A) spectrum in dB(A) via frequency band in Hz.

	63	125	250	500	1000	2000	4000	8000		63	125	250	500	1000	2000	4000	8000
40-2-1,5	45	66	73	78	81	77	70	59	90-12-4	40	53	60	65	68	64	57	46
40-2-2	46	67	74	79	82	78	71	60	100-4-7,5	62	82	90	95	97	94	87	76
40-4-0,75	33	54	61	66	69	65	58	47	100-4-9	61	81	89	94	96	93	86	75
40-4-1,5	30	51	58	63	66	62	55	44	100-4-10	60	80	88	93	95	92	85	74
40-4-2	31	52	59	64	67	63	56	45	100-4-15	59	79	87	92	94	91	84	73
40-6	23	44	51	56	59	55	48	37	100-4-20	61	81	89	94	96	93	86	75
40-12	8	29	36	41	44	40	33	22	100-6-3	60	71	79	84	86	83	76	65
45-2-2	47	68	75	80	83	79	72	61	100-6-4	61	69	77	82	84	81	74	63
45-2-3	49	70	77	82	85	81	74	63	100-6-5,5	62	71	79	84	86	83	76	65
45-4-0,75	37	58	65	70	73	69	62	51	100-8-2	55	65	73	78	80	77	70	59
45-4-2	32	53	60	65	68	64	57	46	100-8-3	55	67	75	80	82	79	72	61
45-4-3	34	55	62	67	70	66	59	48	100-8-4	56	67	75	80	82	79	72	61
45-6	25	46	53	58	61	57	50	39	100-8-7,5	47	67	75	80	82	79	72	61
45-12	10	31	38	43	46	42	35	24	100-8-9	46	66	74	79	81	78	71	60
50-2-4	54	74	82	87	89	86	79	68	100-8-15	44	64	72	77	79	76	69	58
50-2-6	55	75	83	88	90	87	80	69	100-8-20	45	65	73	78	80	77	70	59
50-4-1	41	61	69	74	76	73	66	55	100-12-3	45	54	62	67	69	66	59	48
50-4-4	39	59	67	72	74	71	64	53	100-12-4	46	53	61	66	68	65	58	47
50-4-6	40	60	68	73	75	72	65	54	100-12-5,5	47	54	62	67	69	66	59	48
50-6	30	50	58	63	65	62	55	44	125-4/3-10	67	73	85	95	95	91	83	79
50-12	15	35	43	48	50	47	40	29	125-4/3-10	67	73	85	95	95	91	83	79
56-2-6	60	80	88	93	95	92	85	74	125-4/3-15	68	74	86	96	96	92	84	80
56-2-12	61	81	89	94	96	93	86	75	125-4/3-20	70	76	88	98	98	94	86	82
56-4-1	45	65	73	78	80	77	70	59	125-4/3-25	70	76	88	98	98	94	86	82
56-4-1,5	46	66	74	79	81	78	71	60	125-4/3-27	71	77	89	99	99	95	87	83
56-4-2	47	67	75	80	82	79	72	61	125-4/3-30	71	77	89	99	99	95	87	83
56-4-6	44	64	72	77	79	76	69	58	125-4/3-37	72	78	90	100	100	96	88	84
56-4-12	46	66	74	79	81	78	71	60	125-4/3-40	72	78	90	100	100	96	88	84
56-6	35	55	63	68	70	67	60	49	125-6/3-4	63	71	83	87	85	80	71	67
56-8-1,5	31	51	59	64	66	63	56	45	125-6/3-5,5	64	72	84	88	86	81	72	68
56-8-2	32	52	60	65	67	64	57	46	125-6/3-7,5	65	73	85	89	87	82	73	69
56-12	20	40	48	53	55	52	45	34	125-6/3-10	67	75	87	91	89	84	75	71
63-4-1	47	67	75	80	82	79	72	61	125-6/3-15	68	76	88	92	90	85	76	72
63-4-1,5	46	66	74	79	81	78	71	62	125-6/3-20	69	77	89	93	91	86	77	73
63-4-2	49	66	74	79	81	78	71	63	125-6/3-24	69	77	89	93	91	86	77	73
63-4-3	50	68	76	81	83	80	75	64	125-6/3-9	47	53	65	75	75	71	63	59
63-4-4	51	69	77	82	84	81	76	65	125-8/3-15	48	54	66	76	76	72	64	60
63-6-0,75	40	58	66	71	73	70	63	54	125-8/3-20	50	56	68	78	78	74	66	62
63-6-1	41	60	68	73	75	72	65	55	125-8/3-27	50	56	68	78	78	74	66	62
63-8-1,5	31	51	59	64	66	63	56	47	125-8/3-37	51	57	69	79	79	75	67	63
63-8-2	34	51	59	64	66	63	56	48	125-8/3-40	51	57	69	79	79	75	67	63
63-8-3	35	53	61	66	68	65	60	49	125-12/3-4	48	56	68	72	70	65	56	52
63-8-4	36	54	62	67	69	66	61	50	125-12/3-5,5	49	57	69	73	71	66	57	53
63-12-0,75	25	41	49	54	56	53	46	35	125-12/3-7,5	50	58	70	74	72	67	58	54
63-12-1	26	43	51	56	58	55	48	40	125-12/3-10	52	60	72	76	74	69	60	56
71-4-1,5	52	72	80	85	87	84	77	66	125-12/3-15	53	61	73	77	75	70	61	57
71-4-2	51	71	79	84	86	83	76	67	125-12/3-24	54	62	74	78	76	71	62	58
71-4-3	55	70	78	83	85	82	75	69	125-4/6-20	64	72	88	95	97	92	86	82
71-4-4	56	71	79	84	86	83	76	70	125-4/6-22	64	72	88	95	97	92	86	82
71-6-0,75	42	62	70	73	75	72	65	54	125-4/6-25	65	73	89	96	98	93	87	83
71-6-1	43	63	71	73	75	72	65	54	125-4/6-27	65	73	89	96	98	93	87	83
71-6-1,5	44	64	72	74	76	73	66	55	125-4/6-30	65	73	89	96	98	93	87	83
71-8-1,5	37	56	64	69	71	68	62	51	125-4/6-37	65	73	89	96	98	93	87	83
71-8-2	36	56	64	69	71	68	61	52	125-4/6-40	67	75	91	98	100	95	89	85
71-8-3	40	55	63	68	70	67	60	54	125-4/6-50	68	76	92	99	101	96	90	86
71-8-4	41	56	64	69	71	68	61	55	125-6/6-5,5	58	67	80	83	84	81	70	66
71-12-0,75	27	43	51	56	58	55	48	37	125-6/6-7,5	58	67	80	83	84	81	70	66
71-12-1	28	44	52	57	59	56	49	38	125-6/6-10	60	69	82	85	86	83	72	68
71-12-1,5	29	44	52	57	59	56	49	38	125-6/6-15	62	71	84	87	88	85	74	70
80-4-3	56	75	83	89	90	87	81	70	125-6/6-20	63	72	85	88	89	86	75	71
80-4-4	54	74	82	87	89	86	79	71	125-6/6-24	63	72	85	88	89	86	75	71
80-4-5,5	54	74	82	87	89	86	79	72	125-8/6-20	43	51	67	74	76	71	65	61
80-6-1,5	47	64	72	77	79	76	69	58	125-8/6-22	44	52	68	75	77	72	66	62
80-6-2	48	65	73	78	80	77	70	59	125-8/6-27	44	52	68	75	77	72	66	62
80-6-3	49	66	74	79	81	78	71	60	125-8/6-37	45	53	69	76	78	73	67	63
80-8-0,75	45	58	66	71	73	70	63	52	125-8/6-40	46	54	70	77	79	74	68	64
80-8-1	46	59	67	72	74	71	64	53	125-12/6-5,5	43	52	65	68	69	66	55	51
80-8-3	41	60	68	74	75	72	66	55	125-12/6-7,5	43	52	65	68	69	66	55	51
80-8-4	39	59	67	72	74	71	64	56	125-12/6-10	45	54	67	70	71	68	57	53
80-8-5,5	38	58	66	71	73	70	63	57	125-12/6-15	47	56	69	72	73	70	59	55
80-12-1,5	32	47	55	60	62	59	52	41	125-12/6-24	48	57	70	73	74	71	60	56
80-12-2	33	48	56	61	63	60	53	42	125-4/9-22	63	71	88	94	95	90	85	81
80-12-3	34	49	57	62	64	61	54	43	125-4/9-25	63	71	88	94	95	90	85	81
90-4-4	59	80	87	92	95	91	84	76	125-4/9-27	64	72	89	95	96	91	86	82
90-4-5,5	58	79	86	91	94	90	83	72	125-4/9-30	64	72	89	95	96	91	86	82
90-4-7,5	57	78	85	90	93	89	82	71	125-4/9-37	65	73	90	96	97	92	87	83
90-4-9	56	77	84	89	92	88	81	70	125-4/9-40	66	74	91	97	98	93	88	84
90-4-10	56	77	84	89	92	88	81	70	125-4/9-50	68	76	93	99	100	95	90	86
90-6-2	47	68	75	80	83	79	72	61	125-6/9-10	56	66	81	85	84	83	72	68
90-6-3	54	68	75	80	83	79	72	61	125-6/9-15	59	69	84	88	87	86	75	71
90-6-4	55	70	77	82	85	81	74	63	125-6/9-20	62	72	87	91	90	89	78	74
90-8-1	40	61	68	73	76	72	65	54	125-6/9-24	62	72	87	91	90	89	78	74
90-8-2	49	64	71	76	79	75	68	57	125-8/9-22	44	52	69	75	76	71	66	62

## Dimensions in mm

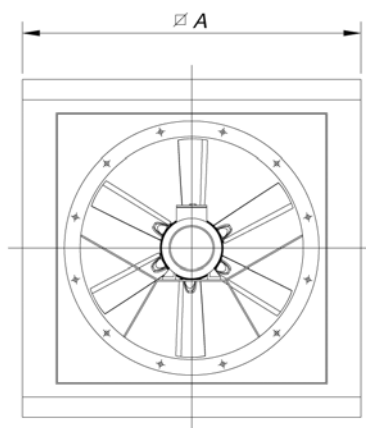
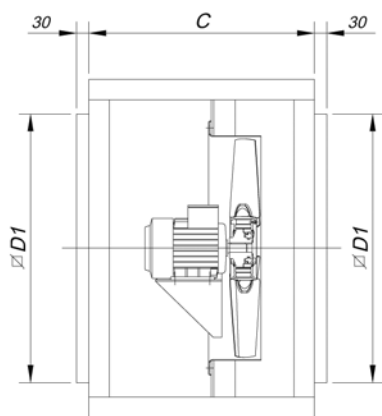

Model	∅A	C	∅D1
CJTHT-40/45/50	700	550	565
CJTHT-56/63	825	550	690
CJTHT-71/80	1000	650	850
CJTHT-90/100	1200	750	1050
CJTHT-125	1600	1200	1400

## Characteristic curves

See characteristic curves on page 33.

## Accessories

See accessories section



# CJTHT/DUPLEX/ATEX



**400°C/2h extraction units, with ATEX certification, category 2 Ex II2G In accordance with Spanish Low Voltage Regulation ITC 29 ATEX and NBE-CP/96 for Zone 1 and 2 rated car parks.**

Duplex extraction units with soundproofed box to work inside fire danger zones at 400°C/2h, with ATEX certification, category 2 Ex II2G In accordance with Spanish Low Voltage Regulation ITC 29 ATEX for Zone 1 and 2 rated car parks.

**Fan:**

- Galvanised sheet steel structure with thermal insulation and soundproofing.
- Turnable impellers cast aluminium.
- Duplex extraction units consisting of:
- CJTHT/ATEX category 3, 400°C/2h to smoke extraction in the event of fire, certificate No.: 0370-CPD-0312
- CJHCH/ATEX category 2 to CO extraction during normal operation
- Airflow direction from motor to impeller

**Motor:**

- Class H motors, ongoing use S1 and emergency use S2, with ball bearings and IP55 protection
- Three-phase 230/400V.-50Hz. (up to 4CV.) and 400/690V.-50Hz. (power over 4CV.)
- Max. temperature of air for transport: S1 Service -20°C+ 40°C for ongoing use, S2 Service 400°C/2h

**Finish:**

- Anticorrosive galvanized sheet steel.

**On request:**

- Built to work in a horizontal position



## Order code

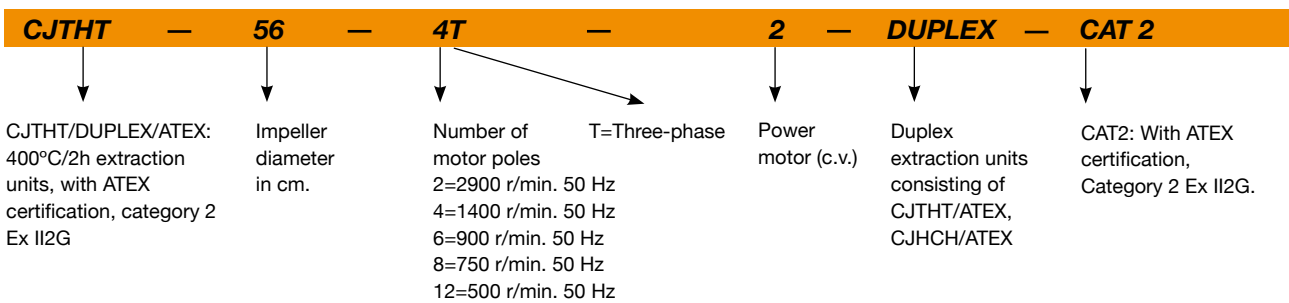

## Technical characteristics

Model	Speed (r/min)	Maximum admissible current (A)			Power installed (kW)	Airflow maximum (m³/h)	Sound pressure level dB(A)	Approx. weight (Kg)
		230V	400V	690V				
CJTHT-40-4T-0,75/DUPLEX-CAT2	1420	2,90	1,70		0,55	4850	61	82
CJTHT-40-6T-0,75/DUPLEX-CAT2	930	3,30	1,90		0,55	3150	51	92
CJTHT-45-4T-0,75/DUPLEX-CAT2	1420	2,90	1,70		0,55	7650	65	85
CJTHT-45-6T-0,75/DUPLEX-CAT2	930	3,30	1,90		0,55	5050	53	95
CJTHT-50-4T-1/DUPLEX-CAT2	1420	3,70	2,10		0,75	9750	66	95
CJTHT-50-6T-0,75/DUPLEX-CAT2	930	3,30	1,90		0,55	7900	55	97
CJTHT-56-4T-1/DUPLEX-CAT2	1420	3,70	2,10		0,75	11850	70	113
CJTHT-56-4T-1,5/DUPLEX-CAT2	1420	4,70	2,70		1,10	13550	71	117
CJTHT-56-4T-2/DUPLEX-CAT2	1425	6,60	3,80		1,50	15450	72	122
CJTHT-56-6T-0,75/DUPLEX-CAT2	930	3,30	1,90		0,55	10900	60	115

## Technical characteristics

Model	Speed (r/min)	Maximum admissible current (A)			Power installed (kW)	Airflow maximum (m³/h)	Sound pressure level dB(A)	Approx. weight (Kg)
		230V	400V	690V				
CJTHT-63-4T-1/DUPLEX-CAT2	1420	3,70	2,10		0,75	15200	70	122
CJTHT-63-4T-1,5/DUPLEX-CAT2	1420	4,70	2,70		1,10	17800	71	126
CJTHT-63-4T-2/DUPLEX-CAT2	1425	6,60	3,80		1,50	20100	72	131
CJTHT-63-4T-3/DUPLEX-CAT2	1435	9,20	5,30		2,20	22300	73	143
CJTHT-63-4T-4/DUPLEX-CAT2	1430	11,40	6,60		3,00	24350	74	150
CJTHT-63-6T-0,75/DUPLEX-CAT2	930	3,30	1,90		0,55	14100	63	124
CJTHT-63-6T-1/DUPLEX-CAT2	940	4,40	2,60		0,75	15950	64	128
CJTHT-71-4T-1,5/DUPLEX-CAT2	1420	4,70	2,70		1,10	19550	75	160
CJTHT-71-4T-2/DUPLEX-CAT2	1425	6,60	3,80		1,50	22200	76	164
CJTHT-71-4T-3/DUPLEX-CAT2	1435	9,20	5,30		2,20	25850	78	177
CJTHT-71-4T-4/DUPLEX-CAT2	1430	11,40	6,60		3,00	29600	79	184
CJTHT-71-6T-0,75/DUPLEX-CAT2	930	3,30	1,90		0,55	16100	65	158
CJTHT-71-6T-1/DUPLEX-CAT2	940	4,40	2,60		0,75	18050	66	161
CJTHT-71-6T-1,5/DUPLEX-CAT2	945	6,40	3,70		1,10	20550	67	166
CJTHT-80-4T-3/DUPLEX-CAT2	1435	9,20	5,30		2,20	25550	79	193
CJTHT-80-4T-4/DUPLEX-CAT2	1430	11,40	6,60		3,00	30400	80	200
CJTHT-80-4T-5,5/DUPLEX-CAT2	1440		8,40	4,80	4,00	32950	81	213
CJTHT-80-6T-1,5/DUPLEX-CAT2	945	6,40	3,70		1,10	21600	70	184
CJTHT-80-6T-2/DUPLEX-CAT2	945	7,40	4,30		1,50	26100	71	196
CJTHT-80-6T-3/DUPLEX-CAT2	950	10,30	5,90		2,20	30000	72	213
CJTHT-90-4T-4/DUPLEX-CAT2	1430	11,40	6,60		3,00	36150	84	248
CJTHT-90-4T-5,5/DUPLEX-CAT2	1440		8,40	4,80	4,00	41650	86	261
CJTHT-90-4T-7,5/DUPLEX-CAT2	1460		13,00	7,50	5,50	46350	88	309
CJTHT-90-4T-10/DUPLEX-CAT2	1460		17,70	10,20	7,50	50300	89	354
CJTHT-90-6T-2/DUPLEX-CAT2	945	7,40	4,30		1,50	28900	75	243
CJTHT-90-6T-3/DUPLEX-CAT2	950	10,30	5,90		2,20	34050	76	261
CJTHT-90-6T-4/DUPLEX-CAT2	970	14,60	8,40		3,00	39050	77	308
CJTHT-100-4T-7,5/DUPLEX-CAT2	1460		13,00	7,50	5,50	50950	89	326
CJTHT-100-4T-10/DUPLEX-CAT2	1460		17,70	10,20	7,50	57650	90	371
CJTHT-100-4T-15/DUPLEX-CAT2	1460		22,00	12,70	11,00	66500	91	436
CJTHT-100-4T-20/DUPLEX-CAT2	1460		29,00	16,70	15,00	76450	92	462
CJTHT-100-6T-3/DUPLEX-CAT2	950	10,30	5,90		2,20	37750	80	277
CJTHT-100-6T-4/DUPLEX-CAT2	970	14,60	8,40		3,00	43550	81	325
CJTHT-100-6T-5,5/DUPLEX-CAT2	970		11,00	6,40	4,00	47950	82	3

(\*) The information refers to a single fan.

## Acoustic features

The specified values are determined according to free field measurements of pressure and sound levels in dB(A) at an equivalent distance of twice the fan's span plus the impeller's diameter, with a minimum of 1.5 m.

Sound power Lw(A) spectrum in dB(A) via frequency band in Hz.

Model	63	125	250	500	1000	2000	4000	8000	Model	63	125	250	500	1000	2000	4000	8000
CJTHT-40-4T-0,75/DUPLEX-CAT2	33	54	61	66	69	65	58	47	CJTHT-71-6T-1/DUPLEX-CAT2	43	63	71	73	75	72	65	54
CJTHT-40-6T-0,75/DUPLEX-CAT2	23	44	51	56	59	55	48	37	CJTHT-71-6T-1,5/DUPLEX-CAT2	44	64	69	74	76	73	66	55
CJTHT-45-4T-0,75/DUPLEX-CAT2	37	58	65	70	73	69	62	51	CJTHT-80-4T-3/DUPLEX-CAT2	56	75	83	89	90	87	81	70
CJTHT-45-6T-0,75/DUPLEX-CAT2	25	46	53	58	61	57	50	39	CJTHT-80-4T-4/DUPLEX-CAT2	54	74	82	87	89	86	79	71
CJTHT-50-4T-1/DUPLEX-CAT2	41	61	69	74	76	73	66	55	CJTHT-80-4T-5,5/DUPLEX-CAT2	54	74	82	87	89	86	79	72
CJTHT-50-6T-0,75/DUPLEX-CAT2	30	50	58	63	65	62	55	44	CJTHT-80-6T-1,5/DUPLEX-CAT2	47	64	72	77	79	76	69	58
CJTHT-56-4T-1/DUPLEX-CAT2	45	65	73	78	80	77	70	59	CJTHT-80-6T-2/DUPLEX-CAT2	48	65	73	78	80	77	70	59
CJTHT-56-4T-1,5/DUPLEX-CAT2	46	66	74	79	81	78	71	60	CJTHT-80-6T-3/DUPLEX-CAT2	49	66	74	79	81	78	71	60
CJTHT-56-4T-2/DUPLEX-CAT2	47	67	75	80	82	79	72	61	CJTHT-80-6T-4/DUPLEX-CAT2	59	80	87	92	95	91	84	76
CJTHT-56-6T-0,75/DUPLEX-CAT2	35	55	63	68	70	67	60	49	CJTHT-90-4T-5,5/DUPLEX-CAT2	58	79	86	91	94	90	83	72
CJTHT-63-4T-1/DUPLEX-CAT2	47	67	75	80	82	79	72	61	CJTHT-90-4T-7,5/DUPLEX-CAT2	57	78	85	90	93	89	82	71
CJTHT-63-4T-1,5/DUPLEX-CAT2	46	66	74	79	81	78	71	62	CJTHT-90-4T-10/DUPLEX-CAT2	56	77	84	89	92	88	81	70
CJTHT-63-4T-2/DUPLEX-CAT2	49	66	74	79	81	78	71	63	CJTHT-90-6T-2/DUPLEX-CAT2	47	68	75	80	83	79	72	61
CJTHT-63-4T-3/DUPLEX-CAT2	50	68	76	81	83	80	75	64	CJTHT-90-6T-3/DUPLEX-CAT2	54	68	75	80	83	79	72	61
CJTHT-63-4T-4/DUPLEX-CAT2	51	69	77	82	84	81	76	65	CJTHT-90-6T-4/DUPLEX-CAT2	55	70	77	82	85	81	74	63
CJTHT-63-6T-0,75/DUPLEX-CAT2	40	58	66	71	73	70	63	54	CJTHT-100-4T-7,5/DUPLEX-CAT2	62	82	90	95	97	94	87	76
CJTHT-63-6T-1/DUPLEX-CAT2	41	60	68	73	75	72	65	55	CJTHT-100-4T-10/DUPLEX-CAT2	60	80	88	93	95	92	85	74
CJTHT-71-4T-1,5/DUPLEX-CAT2	52	72	80	85	87	84	77	66	CJTHT-100-4T-15/DUPLEX-CAT2	59	79	87	92	94	91	84	73
CJTHT-71-4T-2/DUPLEX-CAT2	51	71	79	84	86	83	76	67	CJTHT-100-4T-20/DUPLEX-CAT2	61	81	89	94	96	93	86	75
CJTHT-71-4T-3/DUPLEX-CAT2	55	70	78	83	85	82	75	69	CJTHT-100-6T-3/DUPLEX-CAT2	60	71	79	84	86	83	76	65
CJTHT-71-4T-4/DUPLEX-CAT2	56	71	79	84	86	83	76	70	CJTHT-100-6T-4/DUPLEX-CAT2	61	69	77	82	84	81	74	63
CJTHT-71-6T-0,75/DUPLEX-CAT2	42	62	70	73	75	72	65	54	CJTHT-100-6T-5,5/DUPLEX-CAT2	62	71	79	84	86	83	76	65

**Dimensions in mm**

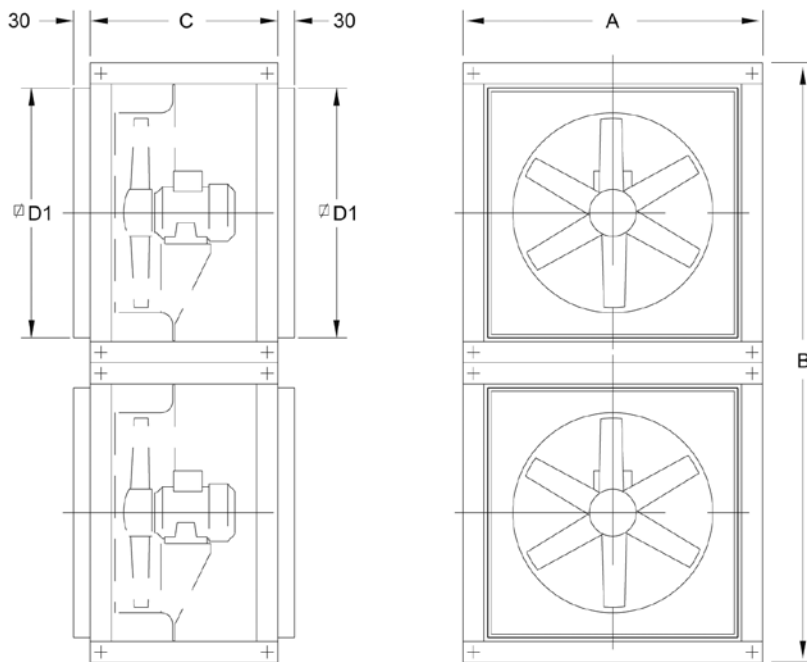

Model	ØA	B	C	ØD1
CJTHT/DUPLEX-40/45/50	700	1400	550	565
CJTHT/DUPLEX-56/63	825	1650	550	690
CJTHT/DUPLEX-71/80	1000	2000	650	850
CJTHT/DUPLEX-90/100	1200	2400	750	1050

**Characteristic Curves**

See characteristic curves on page 33.

**Accessories**

See accessories section



## EXAMPLE OF SELECTION

### Characteristic curves

THT CJTHT/PLUS CJTHT CJTHT/DUPLEX/ATEX:

Q = Airflow in m<sup>3</sup>/h, m<sup>3</sup>/s and cfm.

Pe = Static pressure in mm.w.c., Pa and inwg.

Impeller diameter (cm): 71

Number of poles: 6

Number of blades: 6

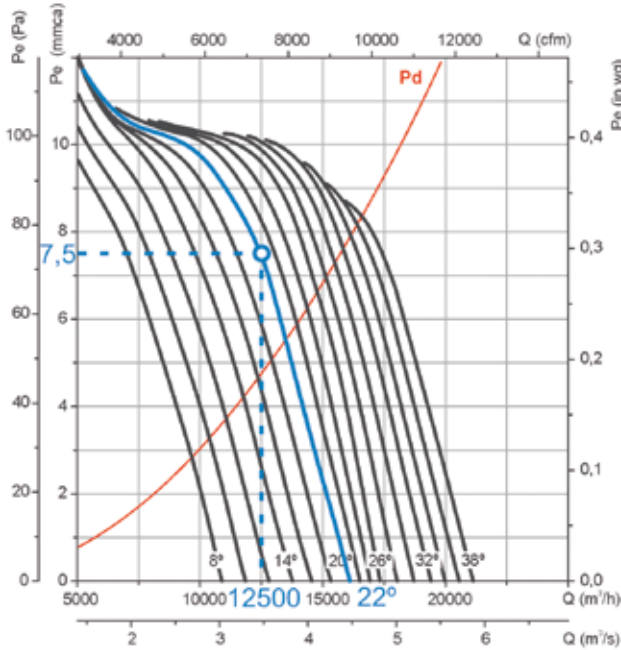

### Initial data

- Working point:
- Airflow: 12,500 m<sup>3</sup>/h
- Loss of load: 7.5 mm w.c.

### Steps for the selection of equipment

#### On the pressure graph:

1. Mark the working point, defined by the airflow (12,500 m<sup>3</sup>/h) and the loss of load (7.5 mm w.c.).
2. Select the curve of the equipment which is closest above the working point. In our case, a curve with a blade angle of 22° is obtained.

#### On the power graph:

3. Mark the working point, defined by the airflow (12,500 m<sup>3</sup>/h) and the selected blade angle (22°).
4. Read the absorbed power on the power axis on the left. Pa = 560 W at the working point.
5. Look for the straight red line which is closest to the working point above. On the right-hand side of the graph, the value of the installed motor power is obtained. In our case, this is 0.75 kW or 1 CV.

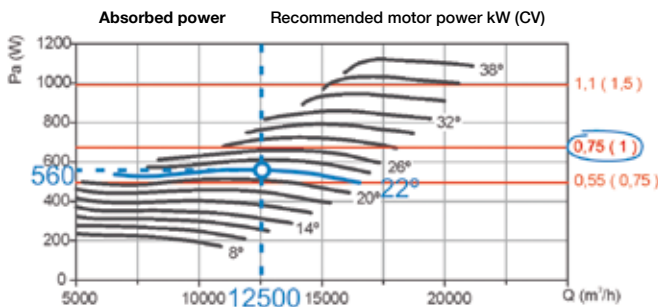

## EXAMPLE OF ORDER CODE

**THT — 71 — 6T — 1 — 6-22 — F-400**

Name of series: THT CJTHT/PLUS CJTHT CJTHT/DUPLEX/ATEX	Impeller diameter in cm. 71	Number of motor poles 2=2900 r/min. 50 Hz 4=1400 r/min. 50 Hz 6=900 r/min. 50 Hz 8=750 r/min. 50 Hz 12=500 r/min. 50 Hz 6T	T=Three-phase M=Single-phase 1	Motor power (c.v.) 1	Number of blades: 3 blades 6 blades 9 blades 6-22	Angle of inclination of the blades 22°	F-200 Officially approved 200°C/2h F-300 Officially approved 300°C/1h F-400 Officially approved 400°C/2h CAT3: With ATEX certification, Category 3 Ex II3G. F-400
--	-----------------------------------	--	--------------------------------------	----------------------------	---	--	---

**Characteristic curves**

THT CJTHT/PLUS CJTHT CJTHT/DUPLEX/ATEX

Q = Airflow in m<sup>3</sup>/h, m<sup>3</sup>/s and cfm.

Pe = Static pressure in mm.w.c., Pa and inwg.

**Impeller diameter (cm): 40    Number of poles: 2    Number of blades: 6**

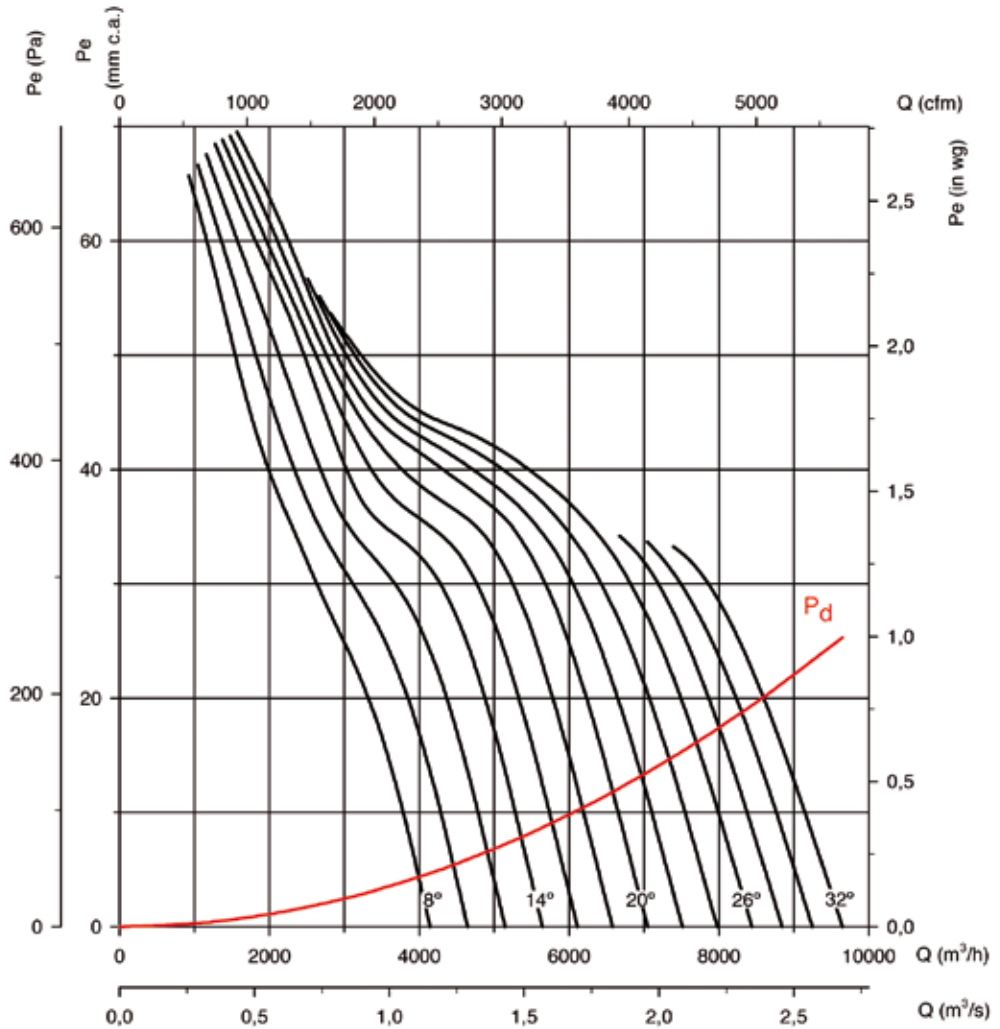

**Absorbed power    Recommended motor power kW (CV)**

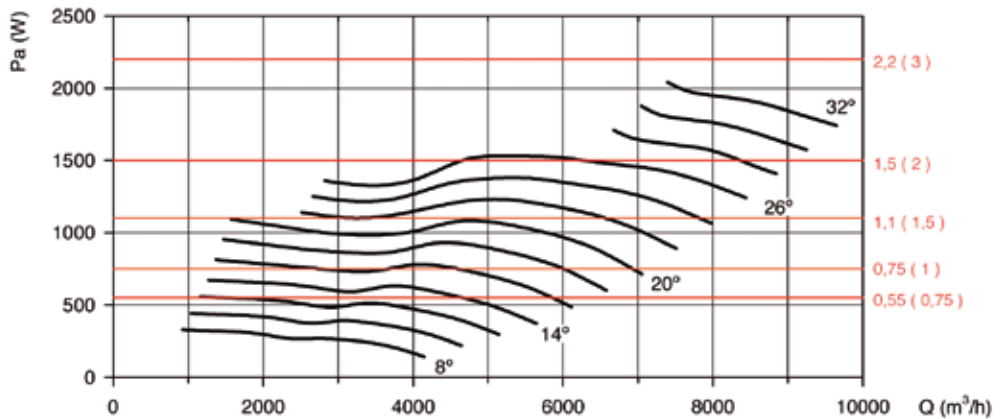

# THT CJTHT/PLUS CJTHT CJTHT/DUPLEX/ATEX

## Characteristic curves

THT CJTHT/PLUS CJTHT CJTHT/DUPLEX/ATEX:

Q = Airflow in m<sup>3</sup>/h, m<sup>3</sup>/s and cfm.

Pe = Static pressure in mm.w.c., Pa and inwg.

Impeller diameter (cm): 40

Number of poles: 4

Number of blades: 6

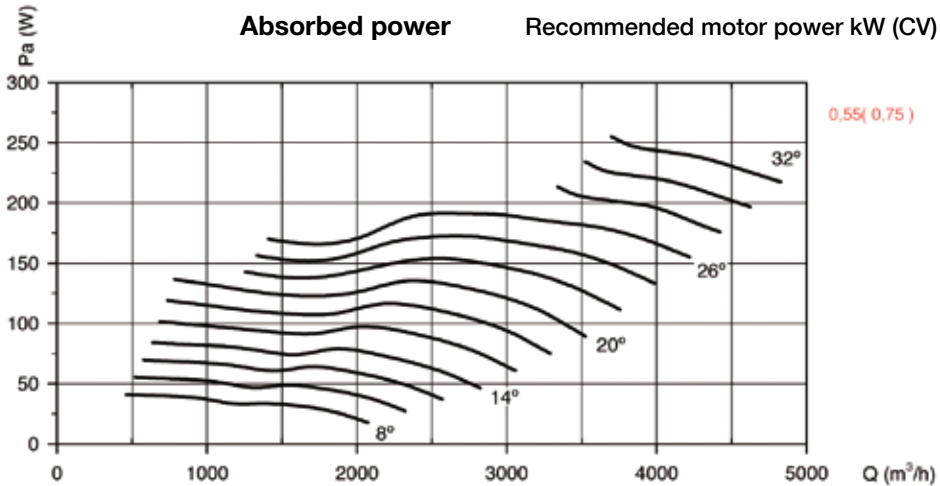
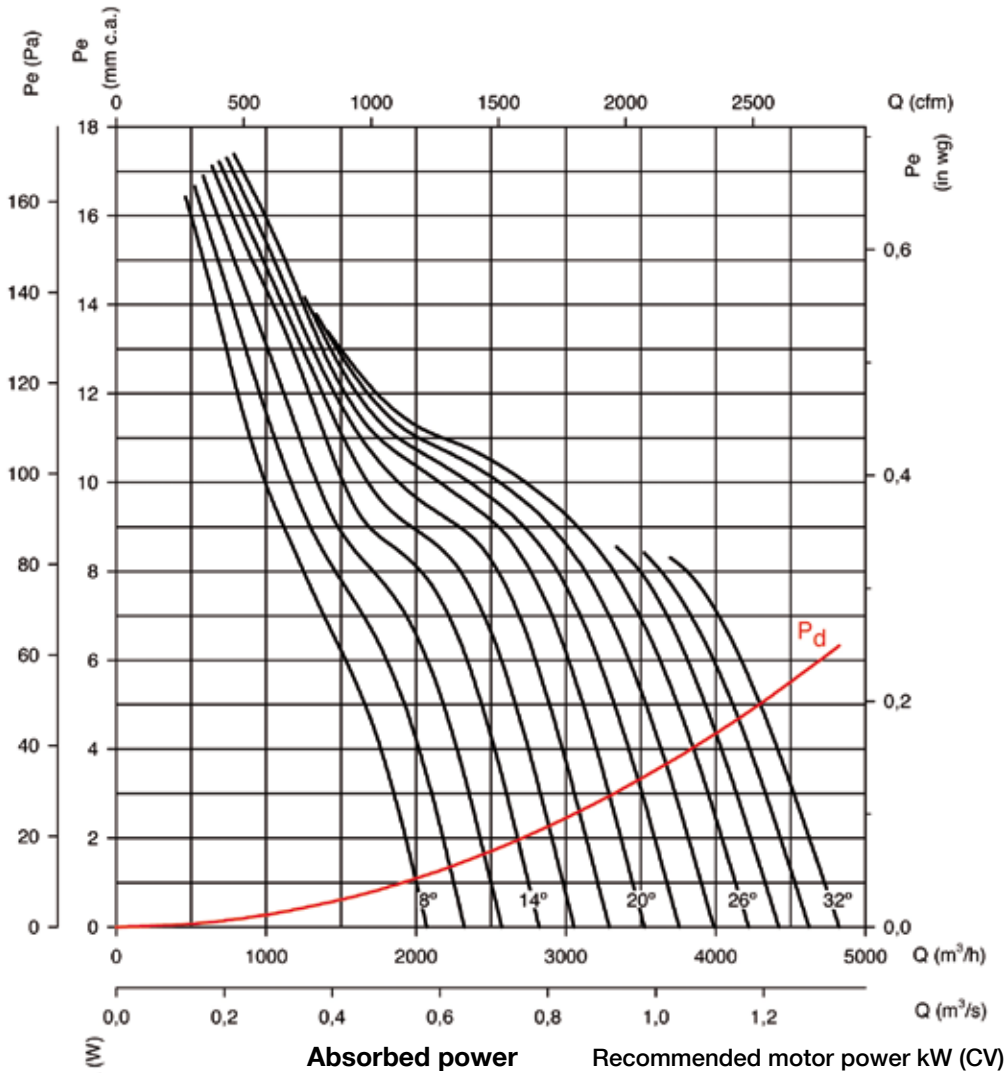

**Characteristic curves**

THT CJTHT/PLUS CJTHT CJTHT/DUPLEX/ATEX:

Q = Airflow in m<sup>3</sup>/h, m<sup>3</sup>/s and cfm.

Pe = Static pressure in mm.w.c., Pa and inwg.

**Impeller diameter (cm): 40**

**Number of poles: 6**

**Number of blades: 6**

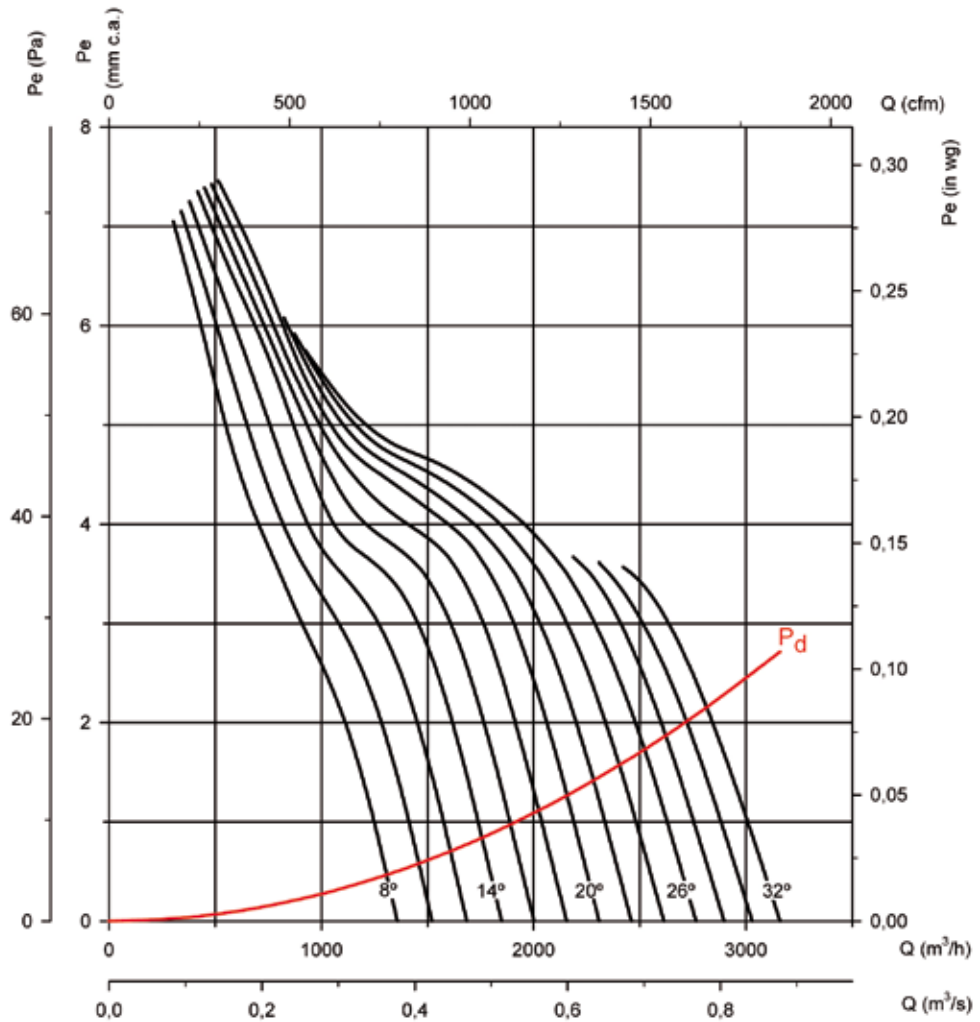

**Absorbed power**

**Recommended motor power kW (CV)**

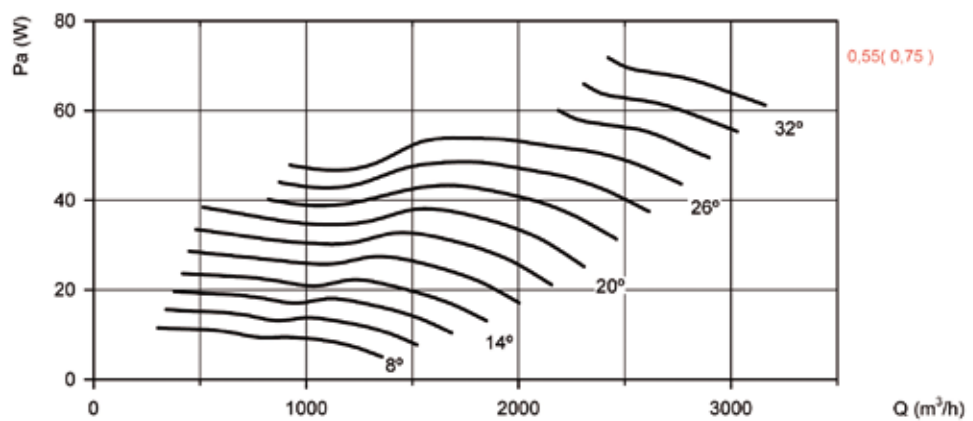

# THT CJTHT/PLUS CJTHT CJTHT/DUPLEX/ATEX

## Characteristic curves

THT CJTHT/PLUS CJTHT CJTHT/DUPLEX/ATEX

Q = Airflow in m<sup>3</sup>/h, m<sup>3</sup>/s and cfm.

Pe = Static pressure in mm.w.c., Pa and inwg.

Impeller diameter (cm): 45

Number of poles: 2

Number of blades: 6

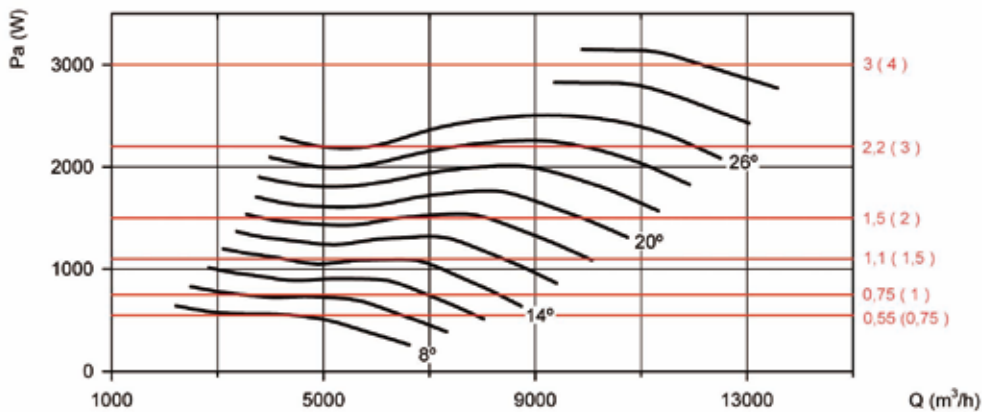
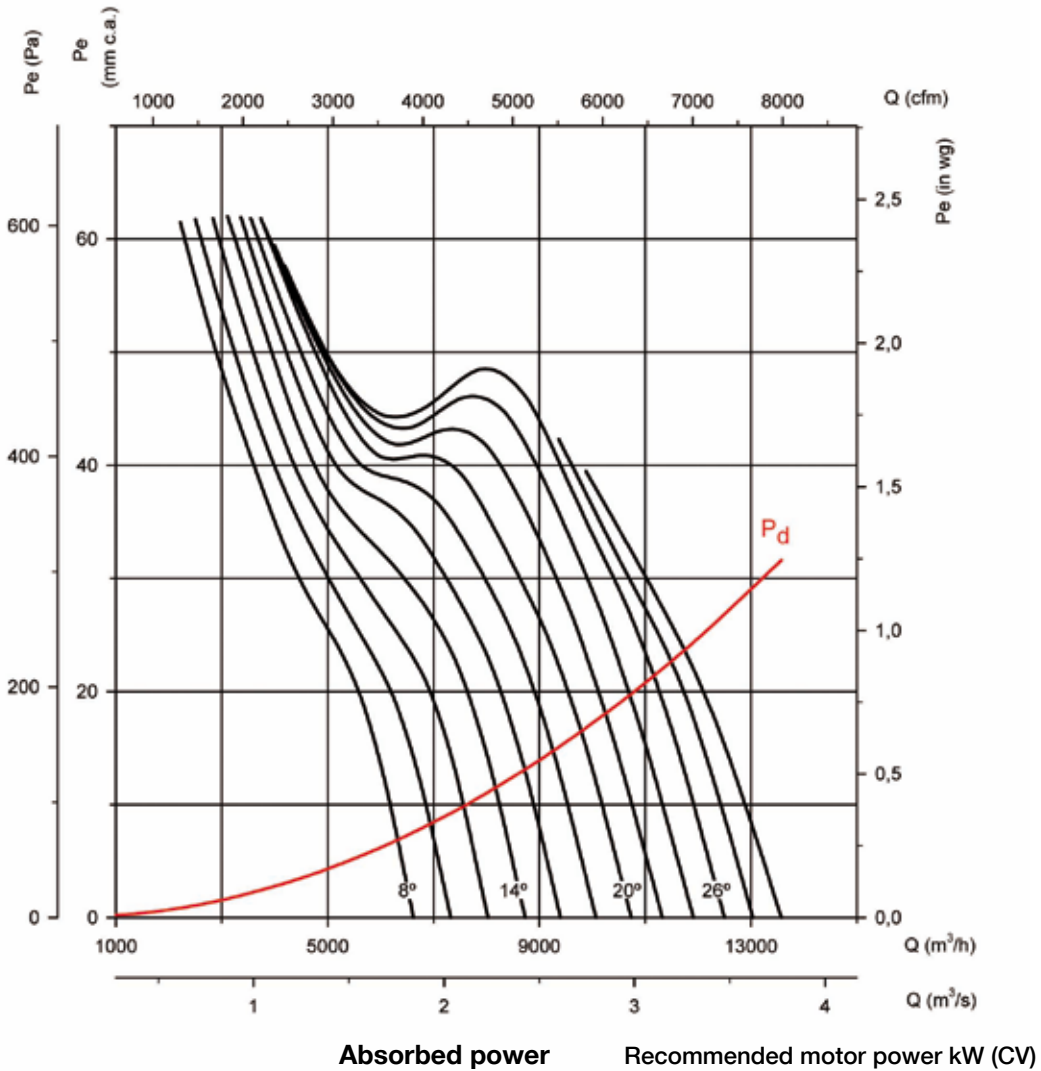

**Characteristic curves**

THT CJTHT/PLUS CJTHT CJTHT/DUPLEX/ATEX:

Q = Airflow in m<sup>3</sup>/h, m<sup>3</sup>/s and cfm.

Pe = Static pressure in mm.w.c., Pa and inwg.

**Impeller diameter (cm): 45**

**Number of poles: 4**

**Number of blades: 6**

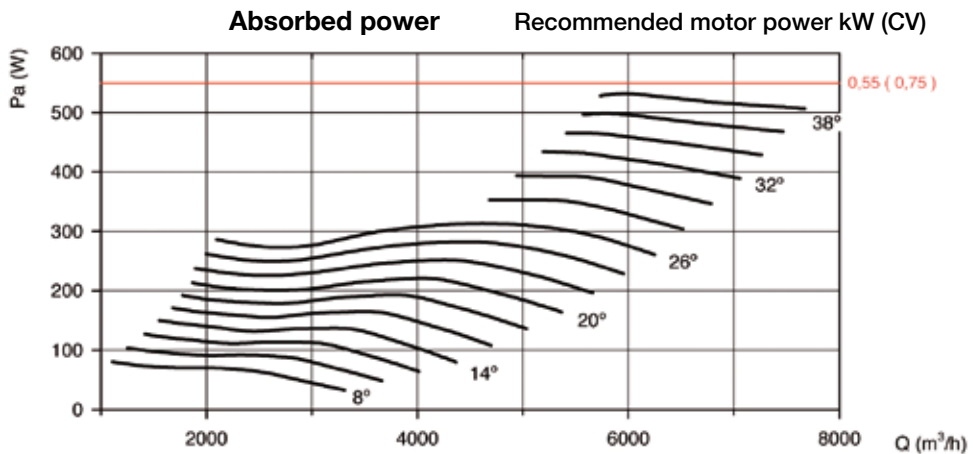
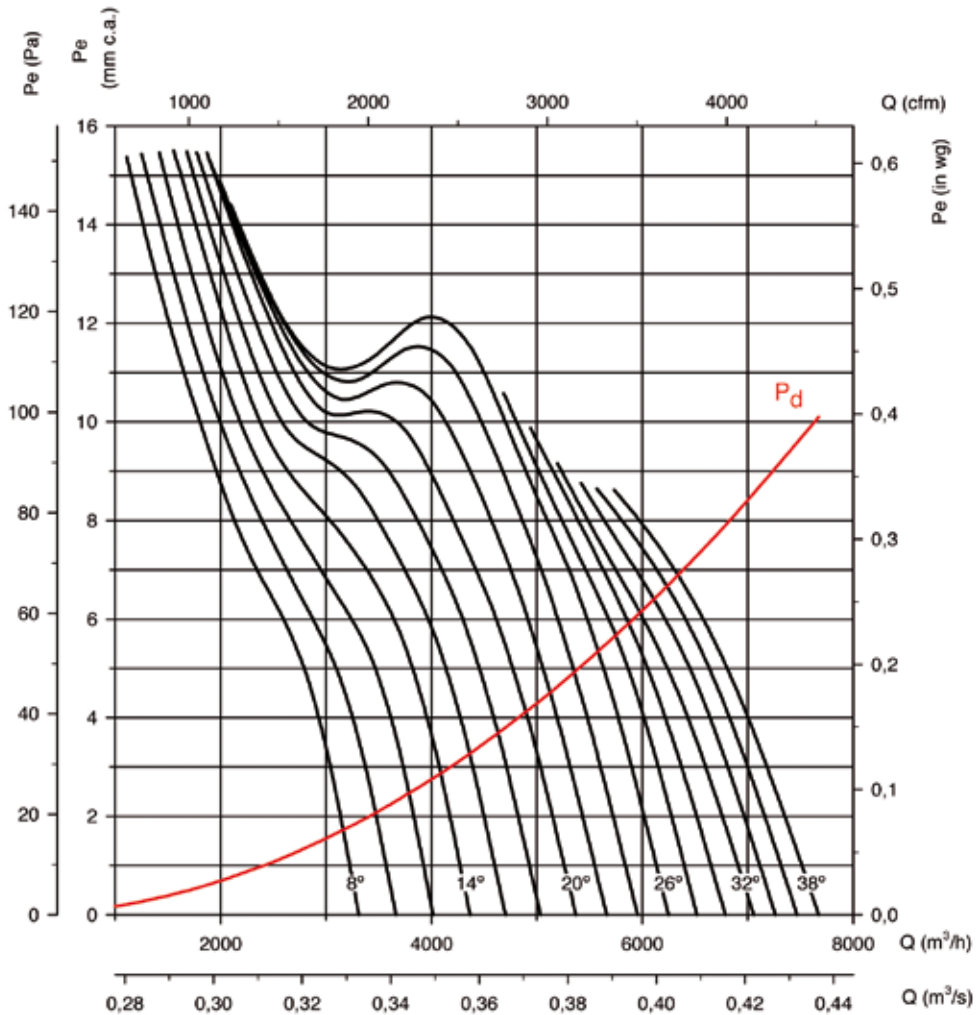

# THT CJTHT/PLUS CJTHT CJTHT/DUPLEX/ATEX

## Characteristic curves

THT CJTHT/PLUS CJTHT CJTHT/DUPLEX/ATEX:

Q = Airflow in m<sup>3</sup>/h, m<sup>3</sup>/s and cfm.

Pe = Static pressure in mm.w.c., Pa and inwg.

Impeller diameter (cm): 45

Number of poles: 6

Number of blades: 6

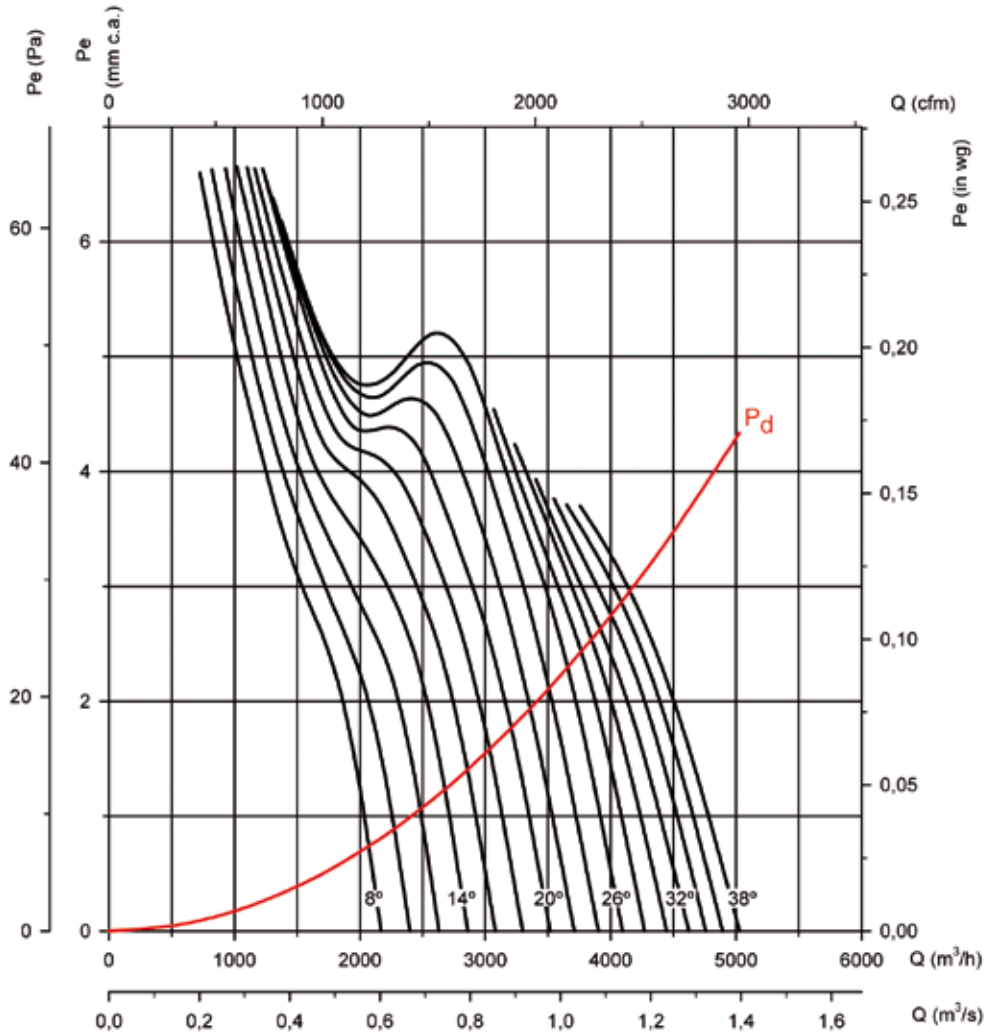

Absorbed power

Recommended motor power kW (CV)

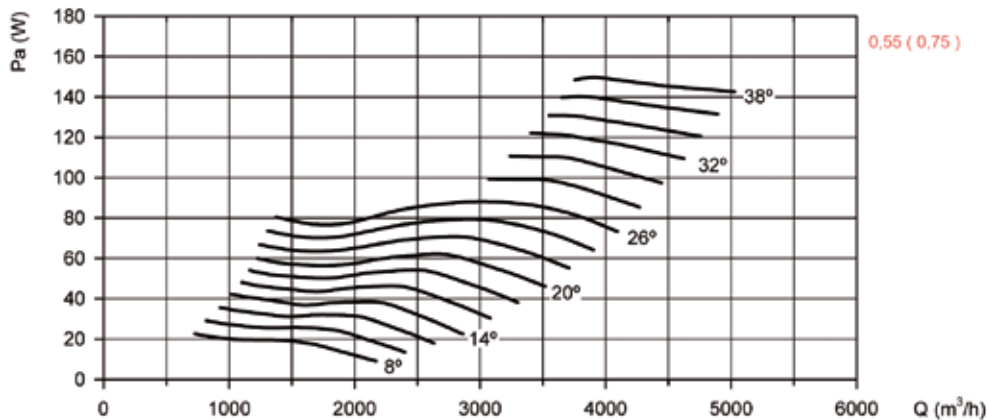

**Characteristic curves**

THT CJTHT/PLUS CJTHT CJTHT/DUPLEX/ATEX

Q = Airflow in m<sup>3</sup>/h, m<sup>3</sup>/s and cfm.

Pe = Static pressure in mm.w.c., Pa and inwg.

**Impeller diameter (cm): 50**

**Number of poles: 2**

**Number of blades: 6**

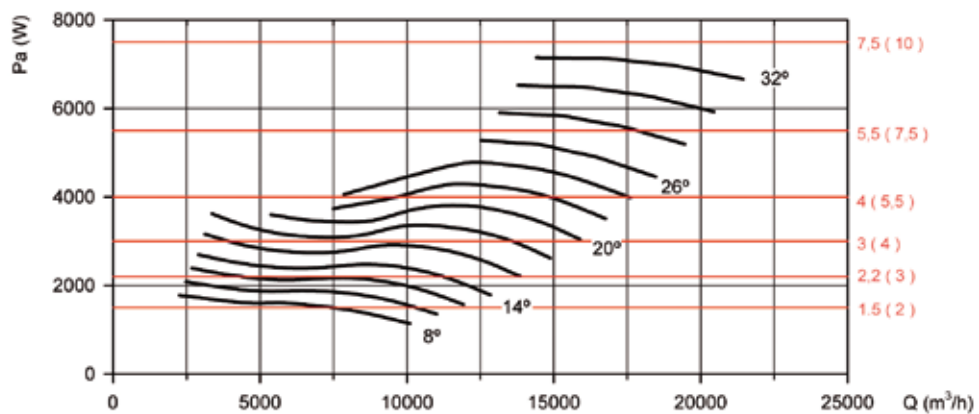
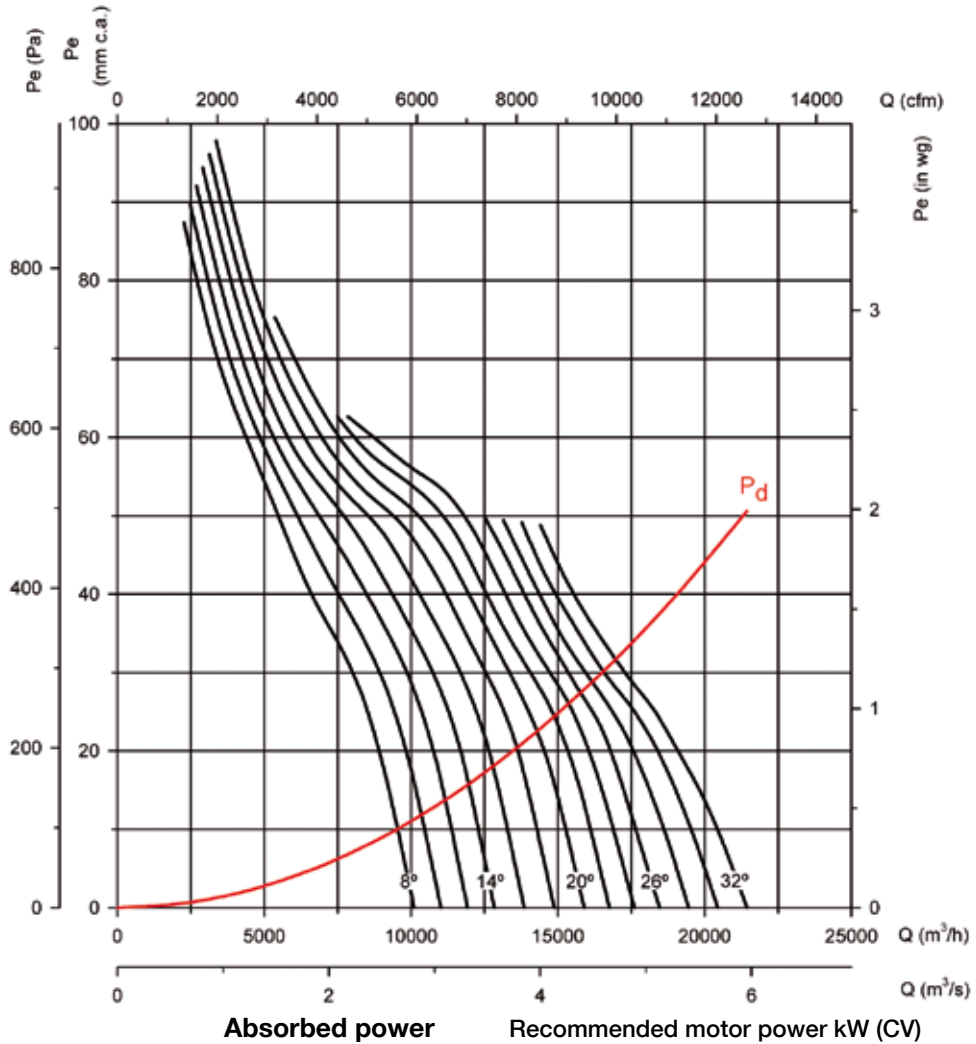

# THT CJTHT/PLUS CJTHT CJTHT/DUPLEX/ATEX

## Characteristic curves

THT CJTHT/PLUS CJTHT CJTHT/DUPLEX/ATEX

Q = Airflow in m<sup>3</sup>/h, m<sup>3</sup>/s and cfm.

Pe = Static pressure in mm.w.c., Pa and inwg.

Impeller diameter (cm): 50

Number of poles: 4

Number of blades: 6

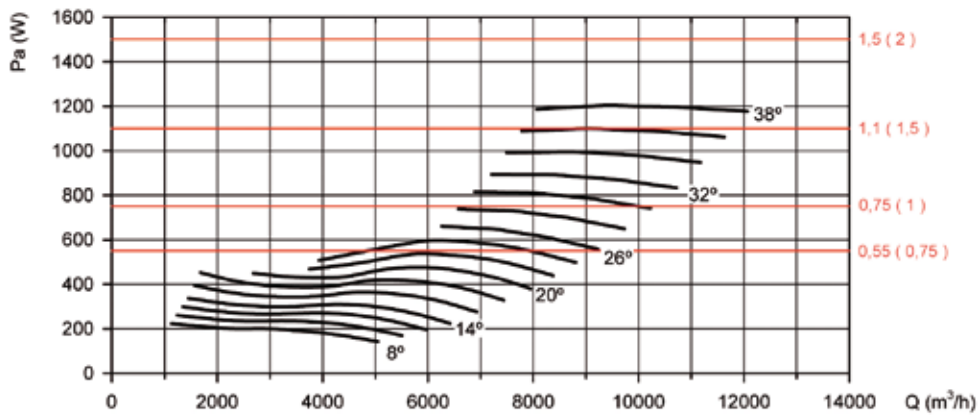
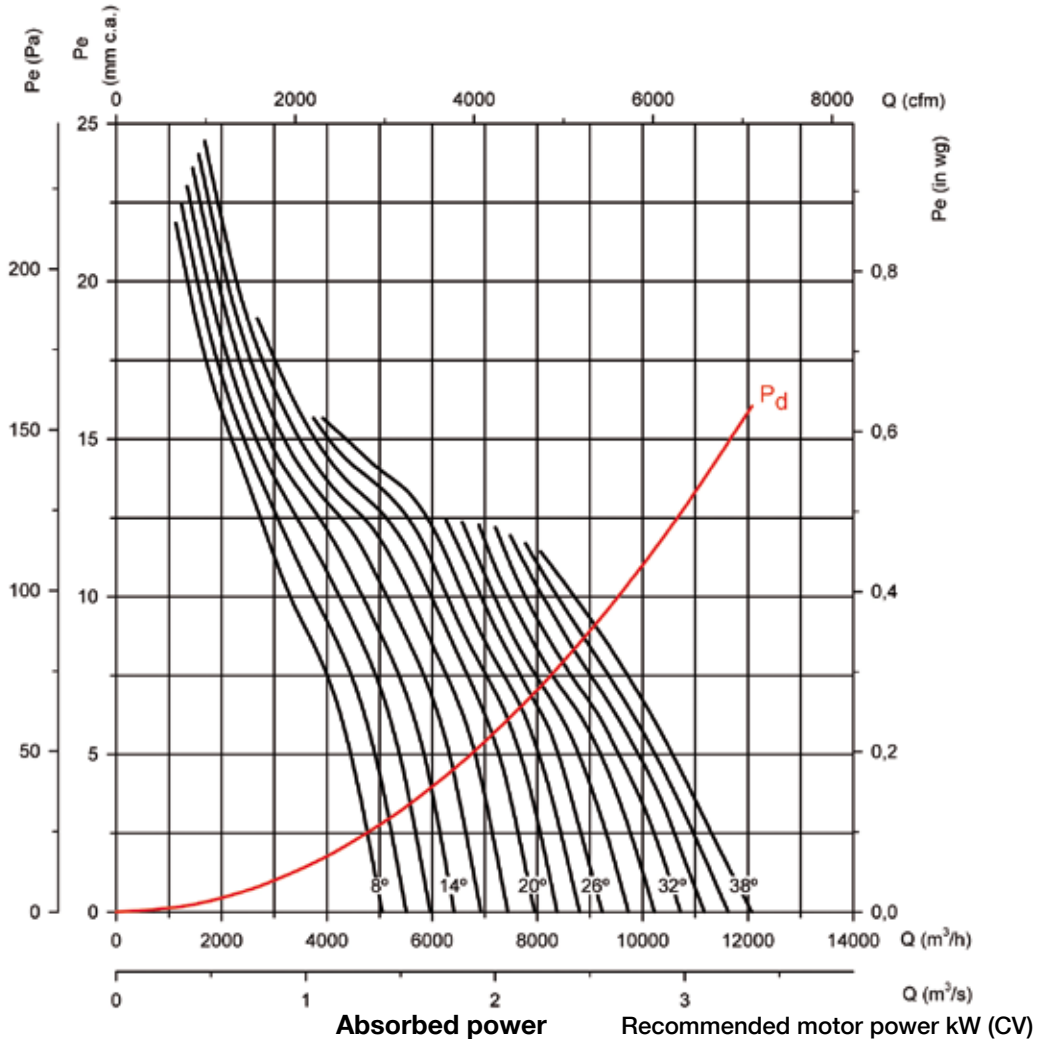

**Characteristic curves**

THT CJTHT/PLUS CJTHT CJTHT/DUPLEX/ATEX

Q = Airflow in m<sup>3</sup>/h, m<sup>3</sup>/s and cfm.

Pe = Static pressure in mm.w.c., Pa and inwg.

**Impeller diameter (cm): 50**

**Number of poles 6**

**Number of blades: 6**

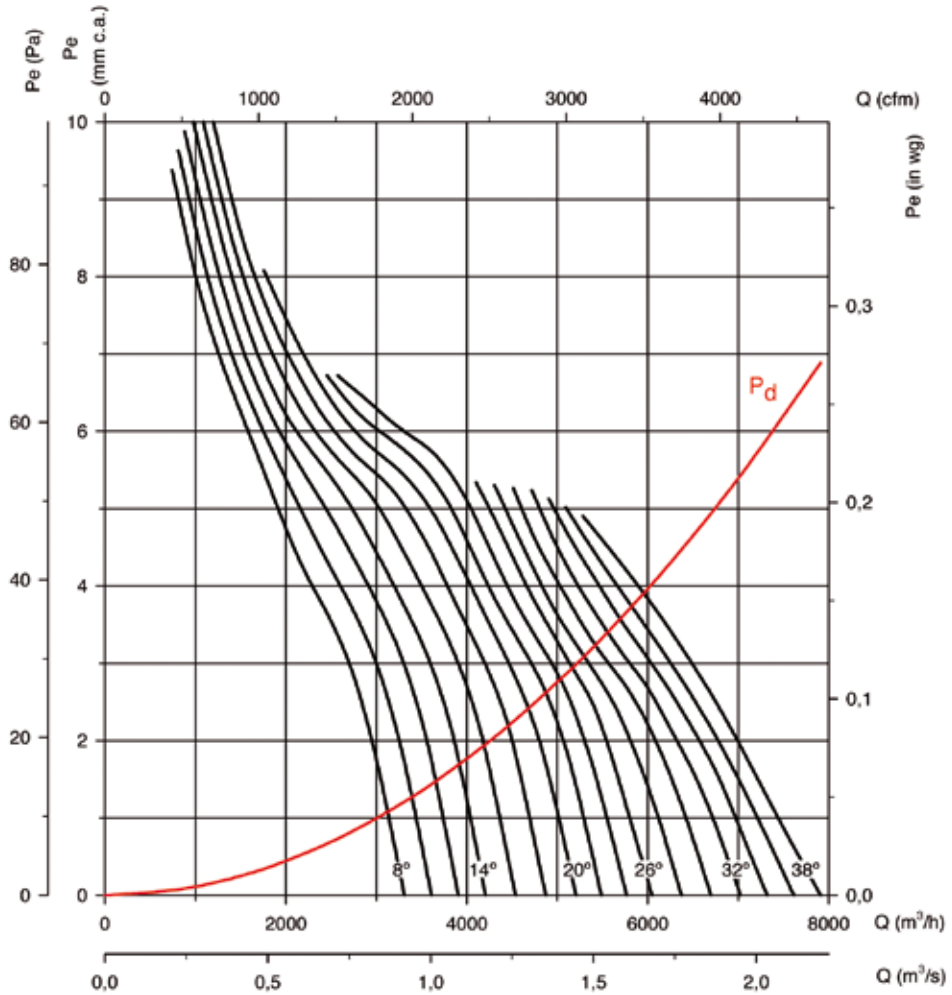

**Absorbed power**

**Recommended motor power kW (CV)**

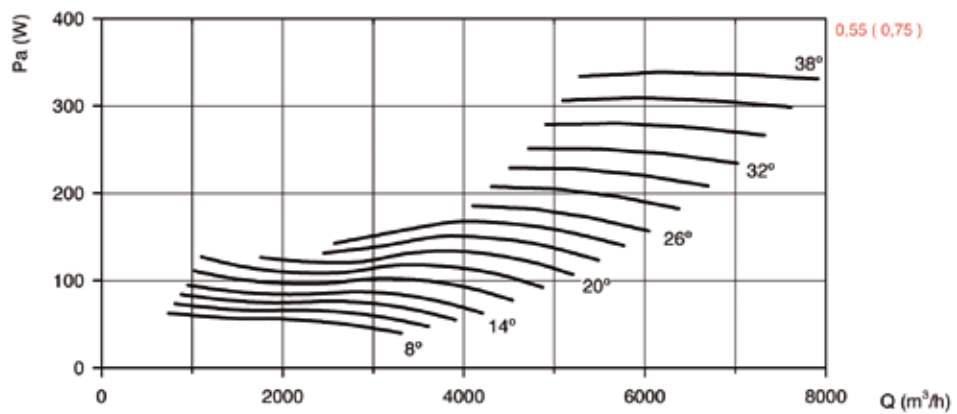

# THT CJTHT/PLUS CJTHT CJTHT/DUPLEX/ATEX

## Characteristic curves

THT CJTHT/PLUS CJTHT CJTHT/DUPLEX/ATEX

Q = Airflow in m<sup>3</sup>/h, m<sup>3</sup>/s and cfm.

Pe = Static pressure in mm.w.c., Pa and inwg.

Impeller diameter (cm): 56

Number of poles: 2

Number of blades: 6

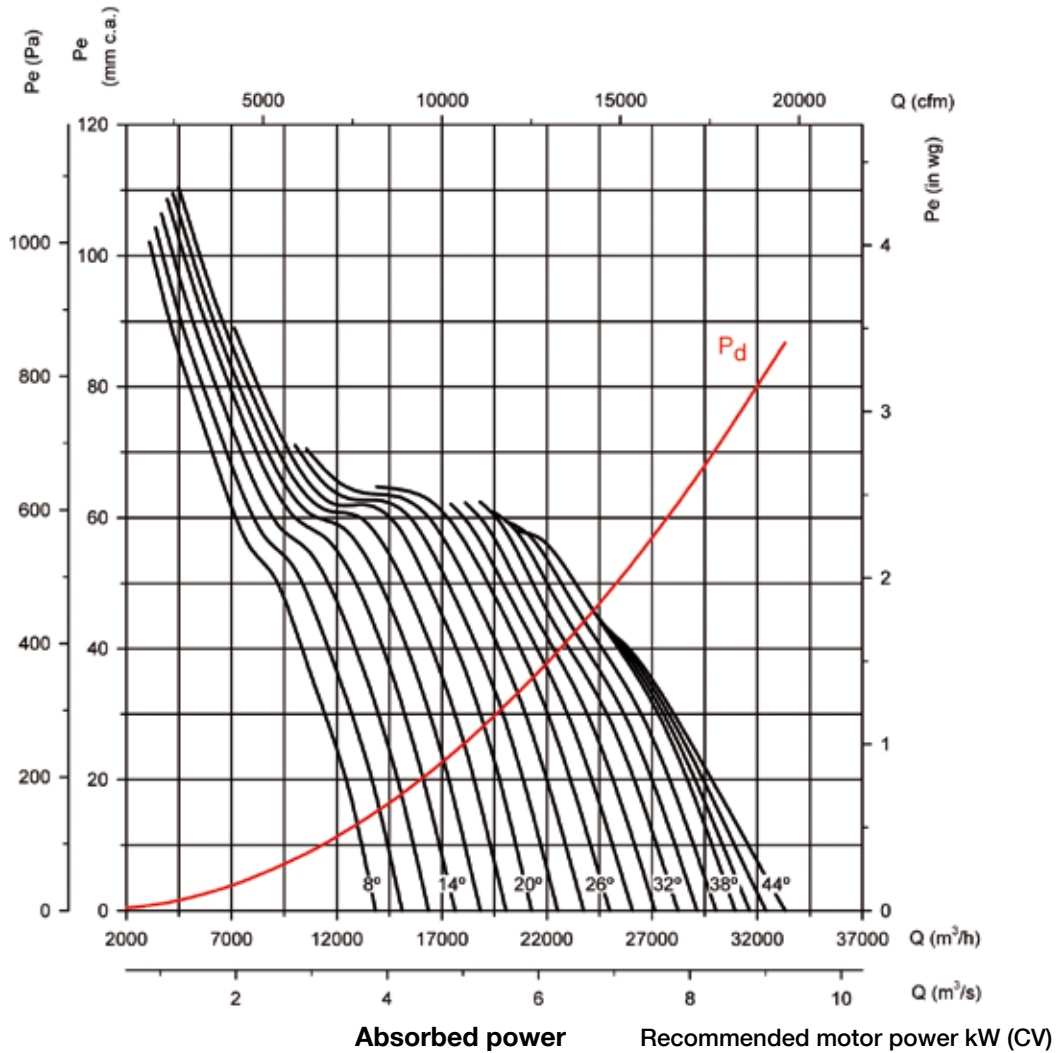

Absorbed power

Recommended motor power kW (CV)

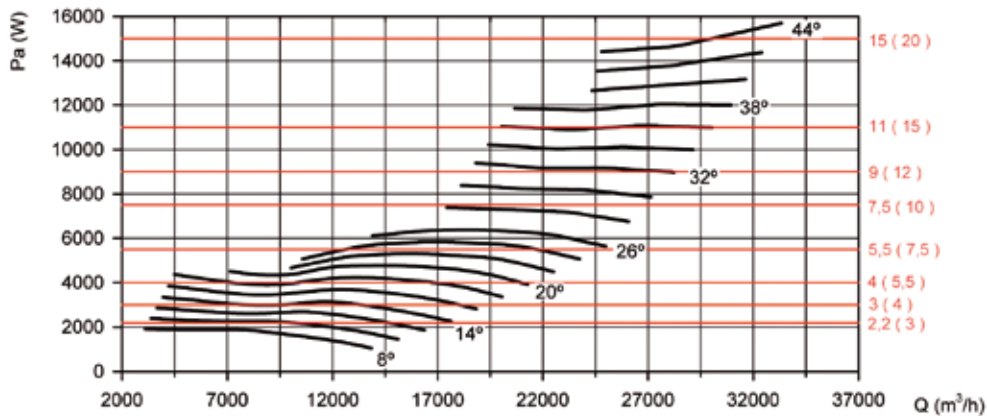

**Characteristic curves**

THT CJTHT/PLUS CJTHT CJTHT/DUPLEX/ATEX

Q = Airflow in m<sup>3</sup>/h, m<sup>3</sup>/s and cfm.

Pe = Static pressure in mm.w.c., Pa and inwg.

**Impeller diameter (cm): 56**

**Number of poles: 4**

**Number of blades: 6**

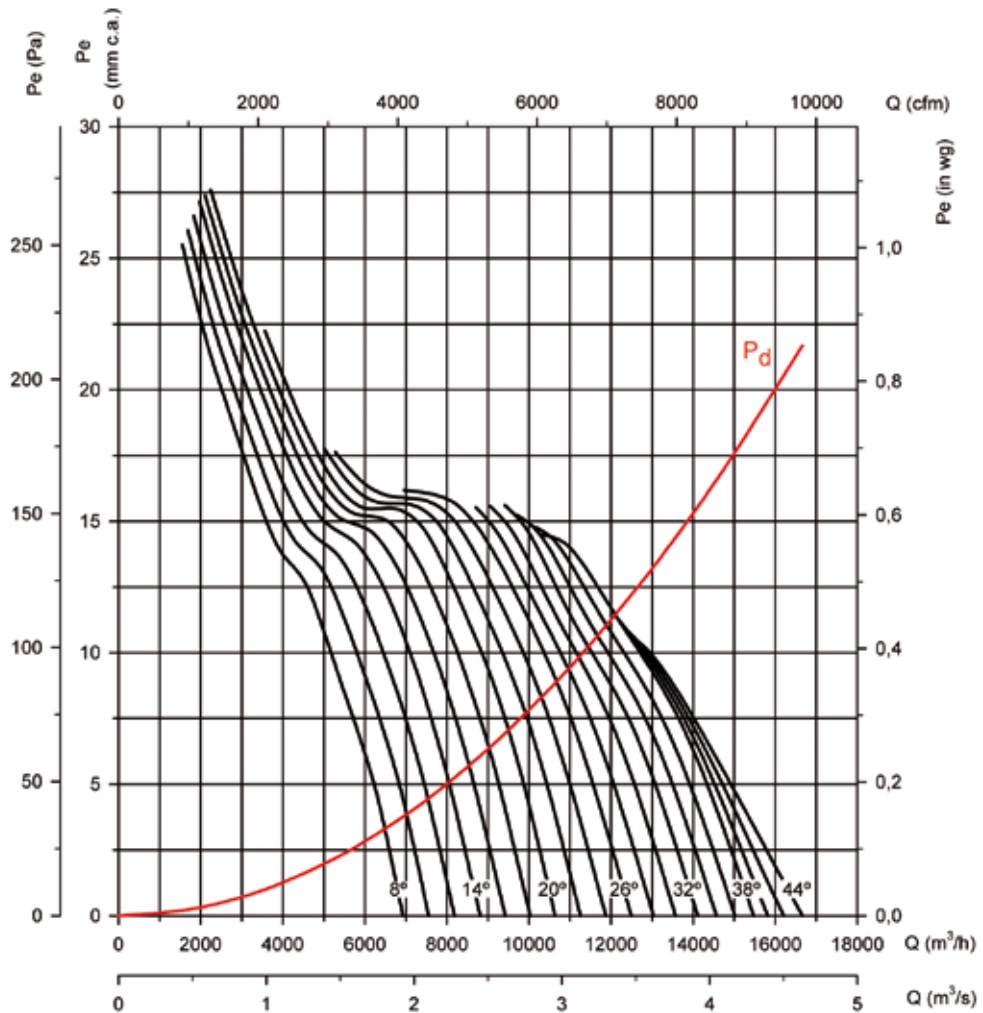

Absorbed power

Recommended motor power kW (CV)

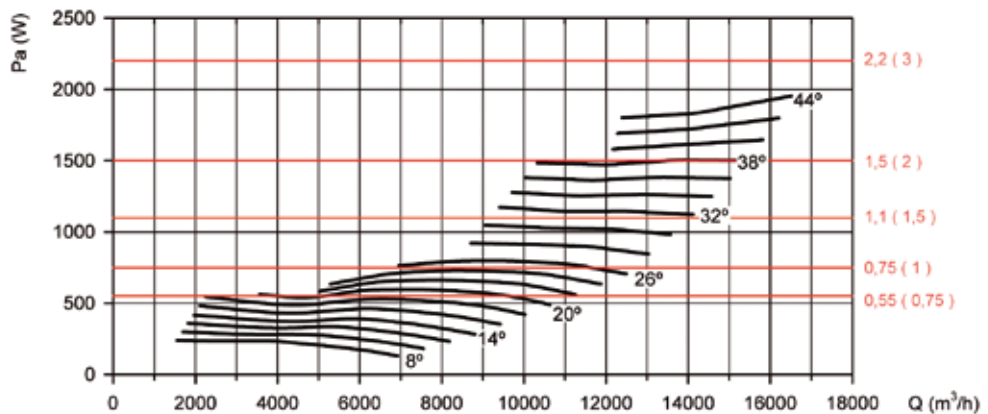

# THT CJTHT/PLUS CJTHT CJTHT/DUPLEX/ATEX

## Characteristic curves

THT CJTHT/PLUS CJTHT CJTHT/DUPLEX/ATEX

Q = Airflow in m<sup>3</sup>/h, m<sup>3</sup>/s and cfm.

Pe = Static pressure in mm.w.c., Pa and inwg.

Impeller diameter (cm): 56

Number of poles: 6

Number of blades: 6

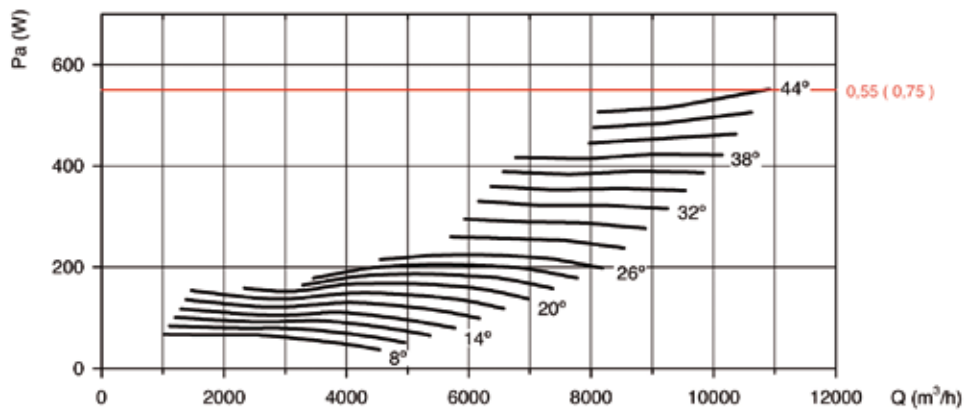
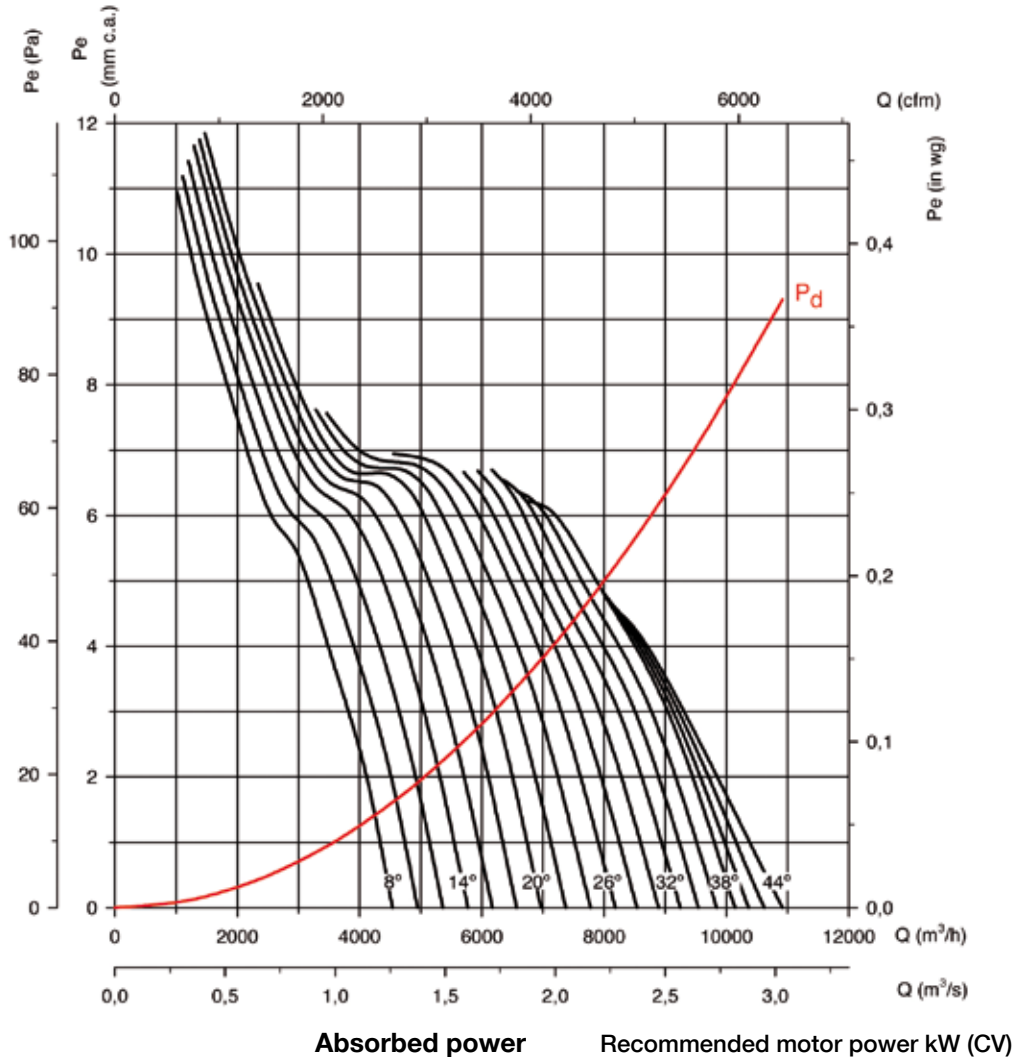

**Characteristic curves**

THT CJTHT/PLUS CJTHT CJTHT/DUPLEX/ATEX

Q = Airflow in m<sup>3</sup>/h, m<sup>3</sup>/s and cfm.

Pe = Static pressure in mm.w.c., Pa and inwg.

**Impeller diameter (cm): 63**

**Number of poles: 2**

**Number of blades: 6**

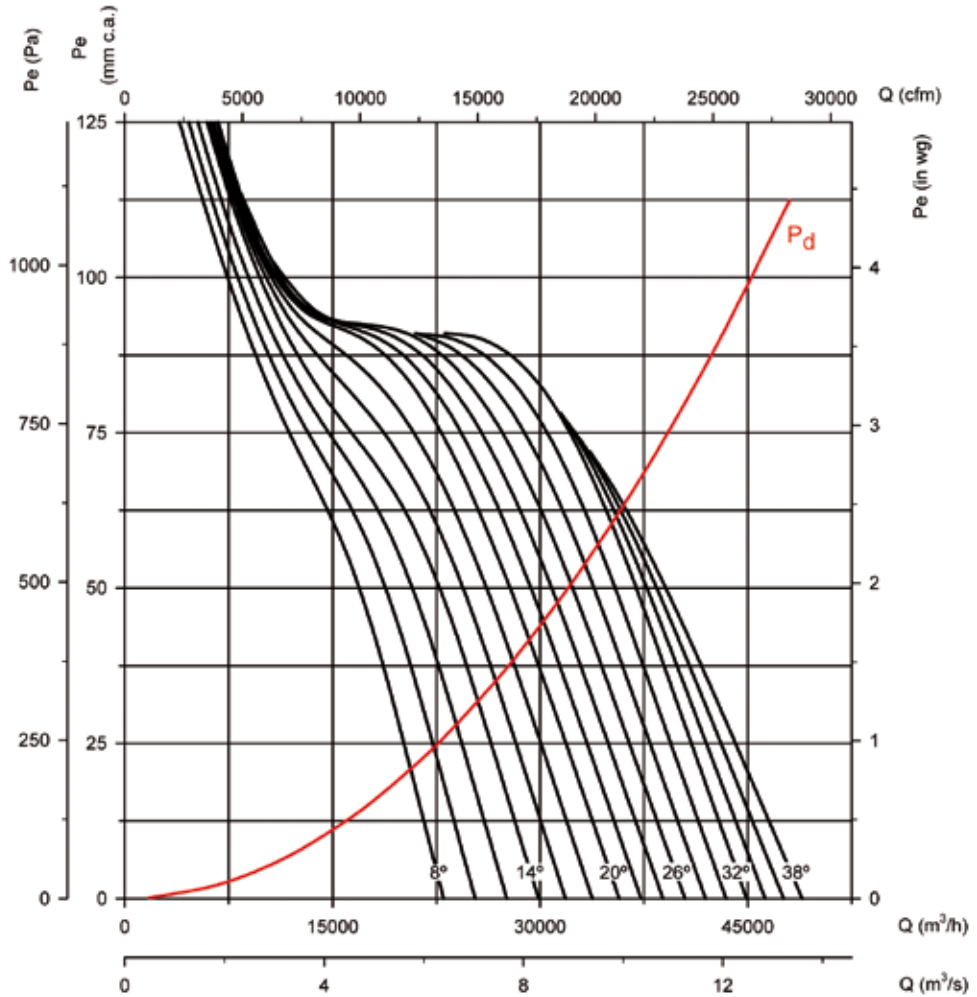

**Absorbed power**

**Recommended motor power kW (CV)**

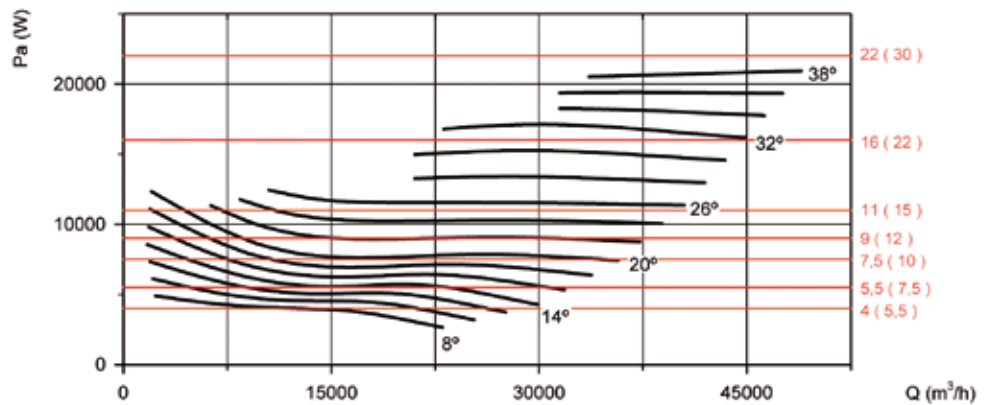

# THT CJTHT/PLUS CJTHT CJTHT/DUPLEX/ATEX

## Characteristic curves

THT

CJTHT/PLUS

CJTHT

CJTHT/DUPLEX/ATEX

Q = Airflow in m<sup>3</sup>/h, m<sup>3</sup>/s and cfm.

Pe = Static pressure in mm.w.c., Pa and inwg.

Impeller diameter (cm): 63

Number of poles: 4

Number of blades: 6

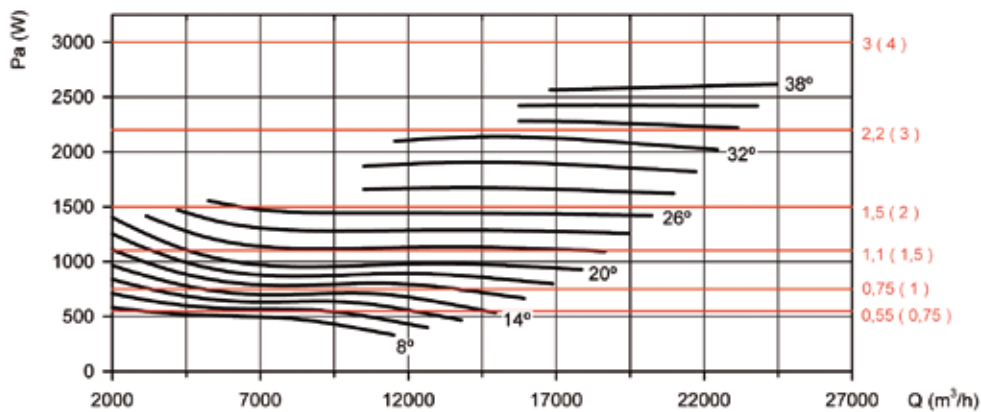
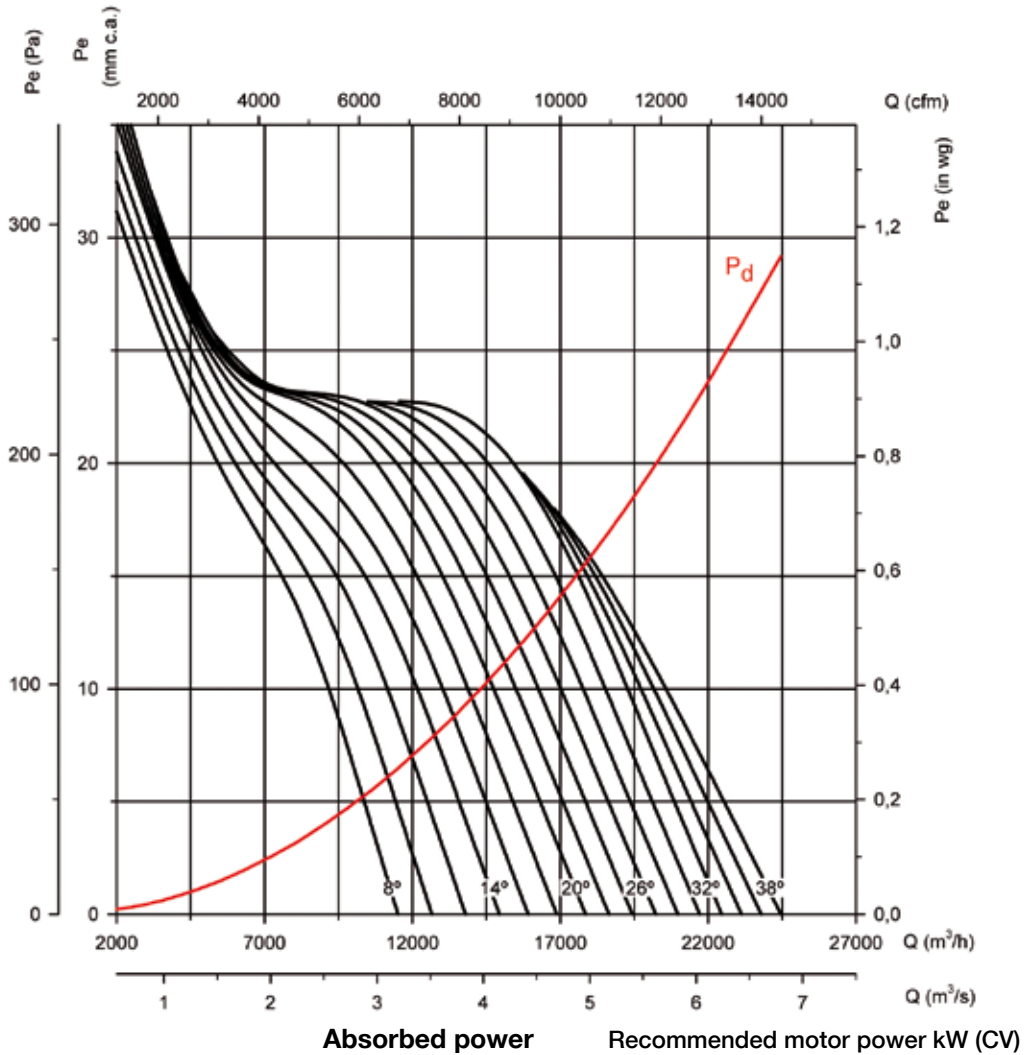

**Characteristic curves**

THT

CJTHT/PLUS

CJTHT

CJTHT/DUPLEX/ATEX

Q = Airflow in m<sup>3</sup>/h, m<sup>3</sup>/s and cfm.

Pe = Static pressure in mm.w.c., Pa and inwg.

**Impeller diameter (cm): 63**

**Number of poles: 6**

**Number of blades: 6**

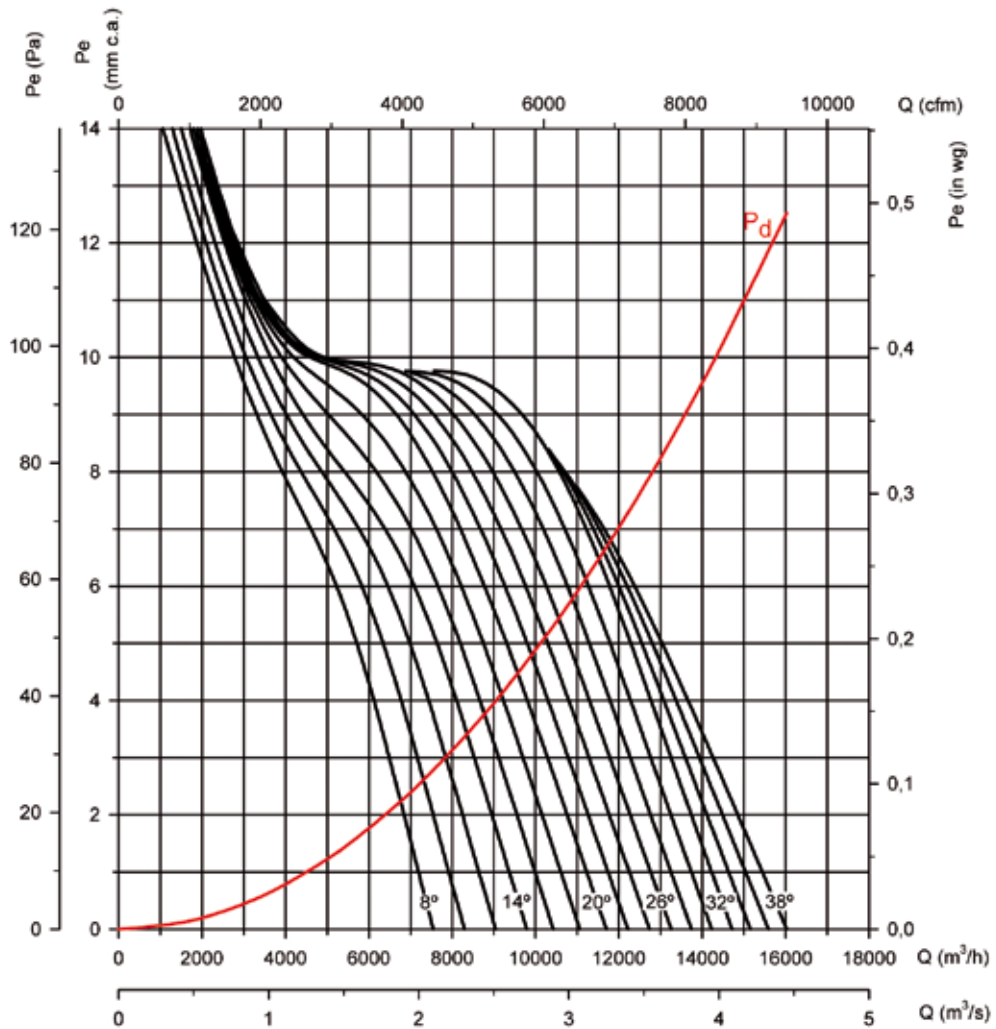

**Absorbed power**

**Recommended motor power kW (CV)**

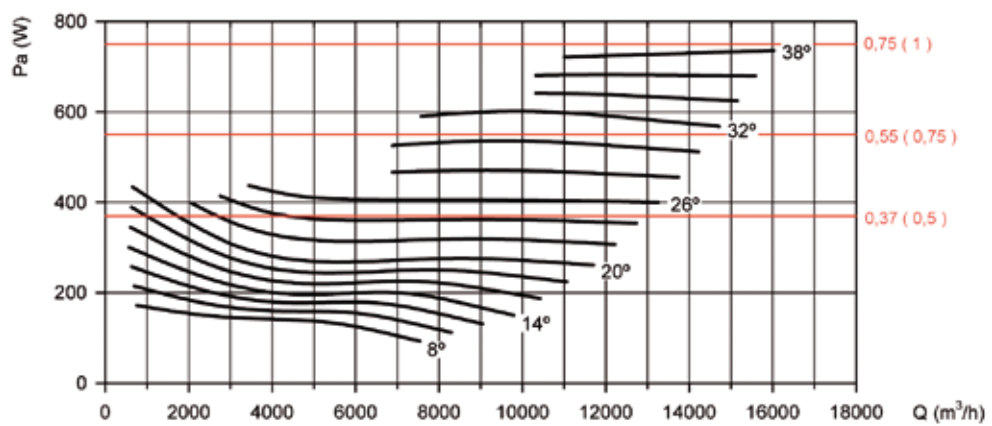

# THT CJTHT/PLUS CJTHT CJTHT/DUPLEX/ATEX

## Characteristic curves

THT CJTHT/PLUS CJTHT CJTHT/DUPLEX/ATEX

Q = Airflow in m<sup>3</sup>/h, m<sup>3</sup>/s and cfm.

Pe = Static pressure in mm.w.c., Pa and inwg.

Impeller diameter (cm): 71

Number of poles: 4

Number of blades: 6

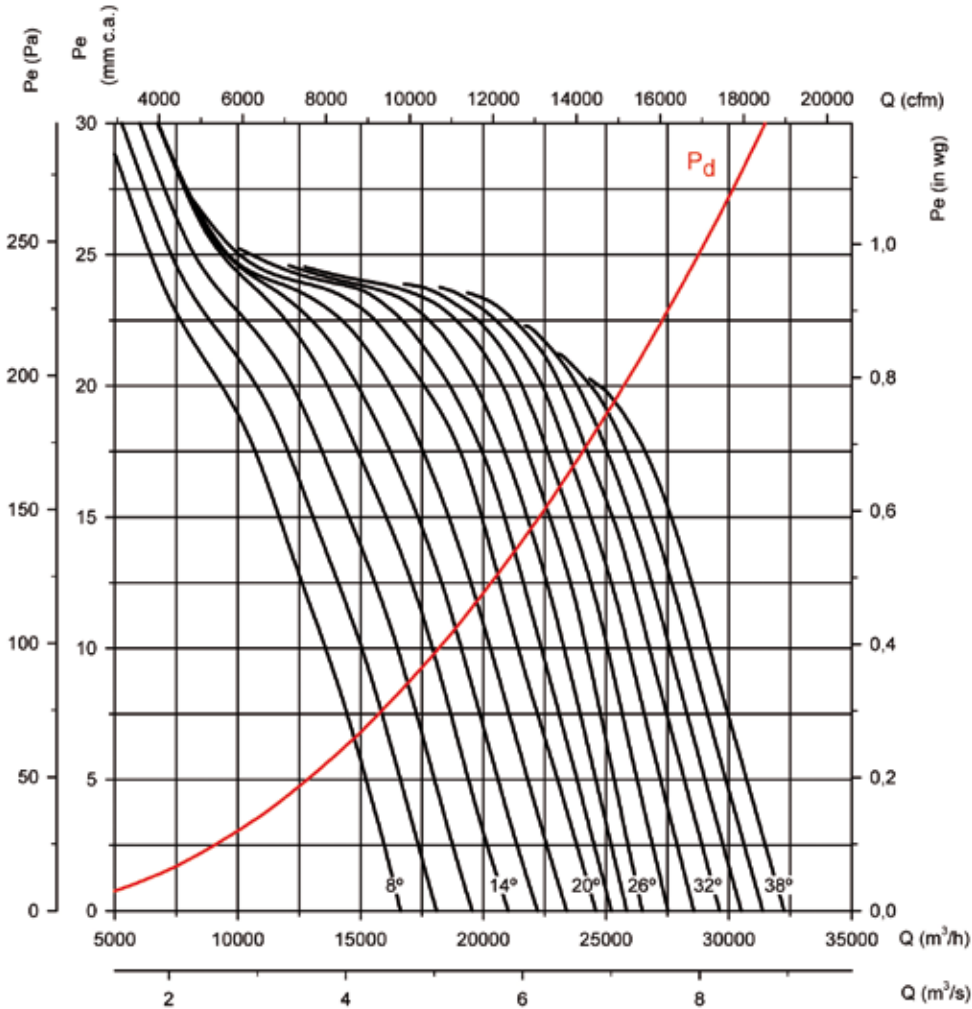

Absorbed power

Recommended motor power kW (CV)

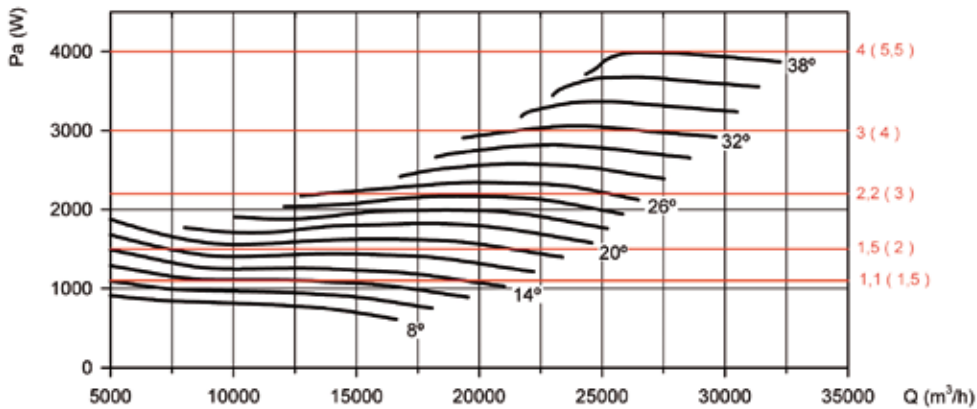

**Characteristic curves**

THT CJTHT/PLUS CJTHT CJTHT/DUPLEX/ATEX

Q = Airflow in m<sup>3</sup>/h, m<sup>3</sup>/s and cfm.

Pe = Static pressure in mm.w.c., Pa and inwg.

**Impeller diameter (cm): 71    Number of poles: 6    Number of blades: 6**

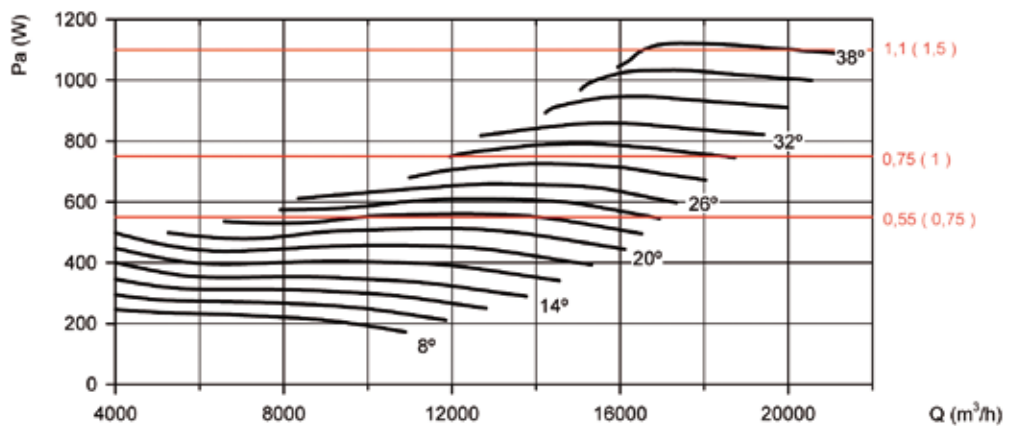
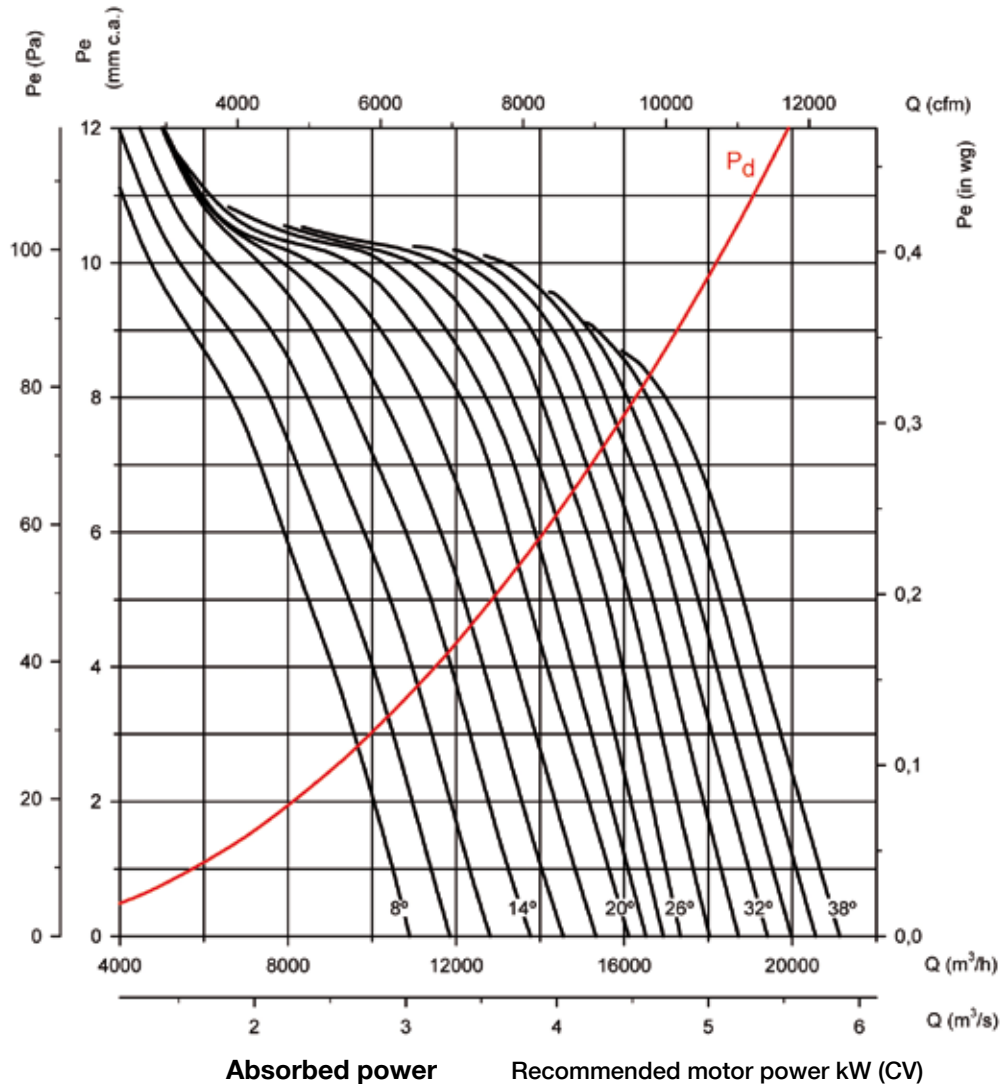

# THT CJTHT/PLUS CJTHT CJTHT/DUPLEX/ATEX

## Characteristic curves

THT CJTHT/PLUS CJTHT CJTHT/DUPLEX/ATEX

Q = Airflow in m<sup>3</sup>/h, m<sup>3</sup>/s and cfm.

Pe = Static pressure in mm.w.c., Pa and inwg.

Impeller diameter (cm): 80

Number of poles: 4

Number of blades: 6

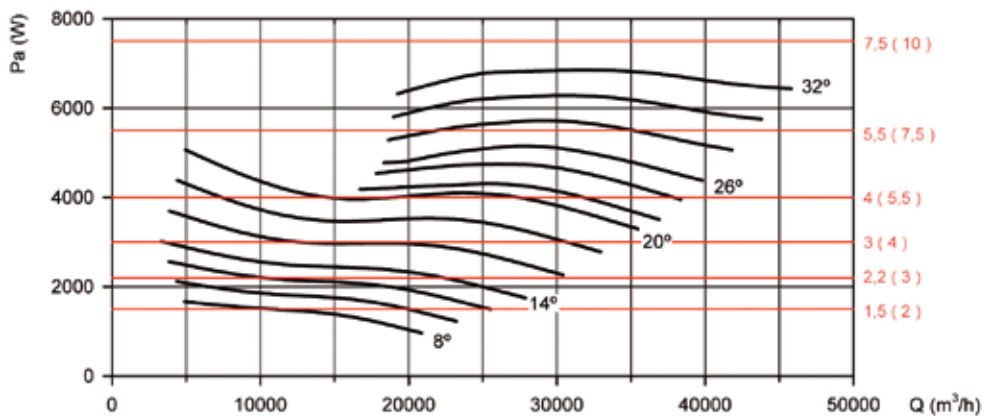
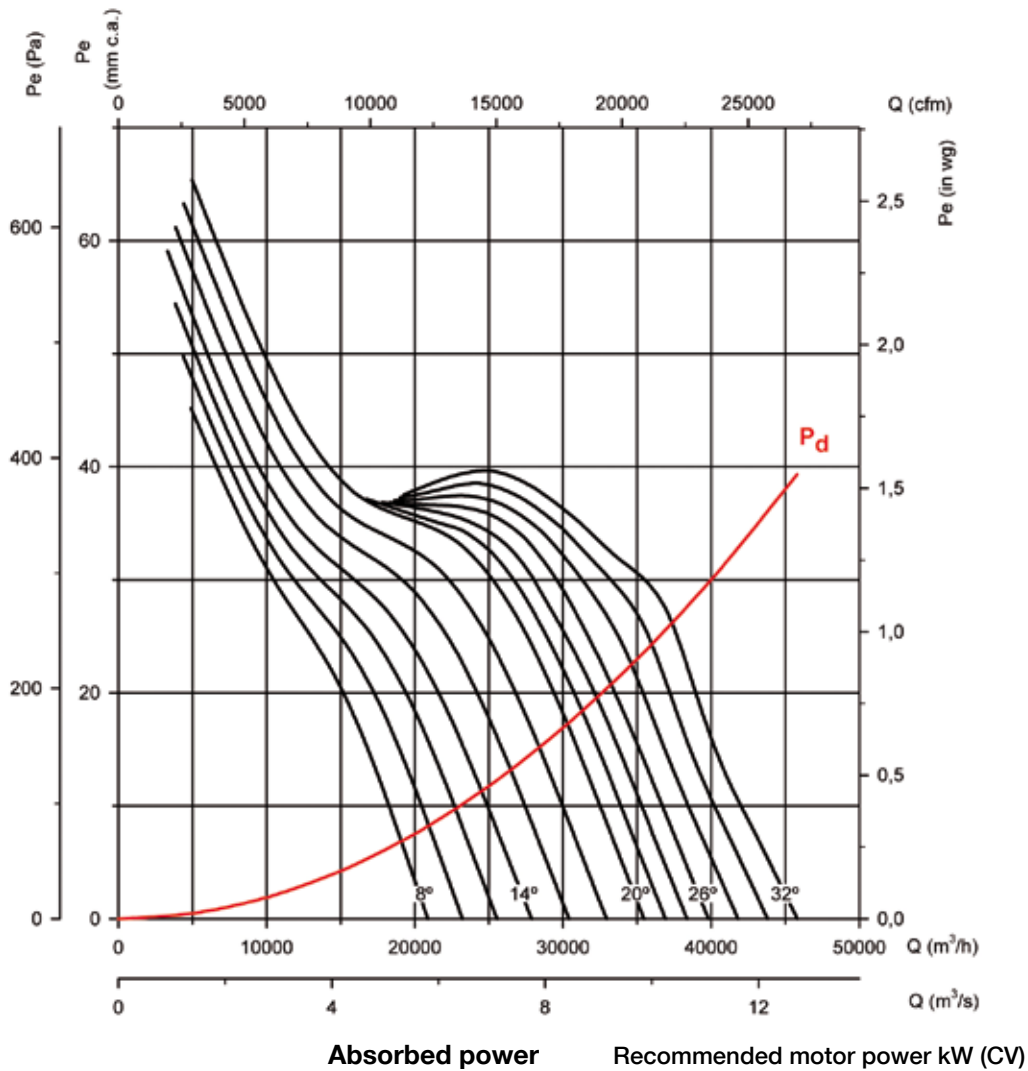

**Characteristic curves**

THT

CJTHT/PLUS

CJTHT

CJTHT/DUPLEX/ATEX

Q = Airflow in m<sup>3</sup>/h, m<sup>3</sup>/s and cfm.

Pe = Static pressure in mm.w.c., Pa and inwg.

**Impeller diameter (cm): 80**

**Number of poles: 6**

**Number of blades: 6**

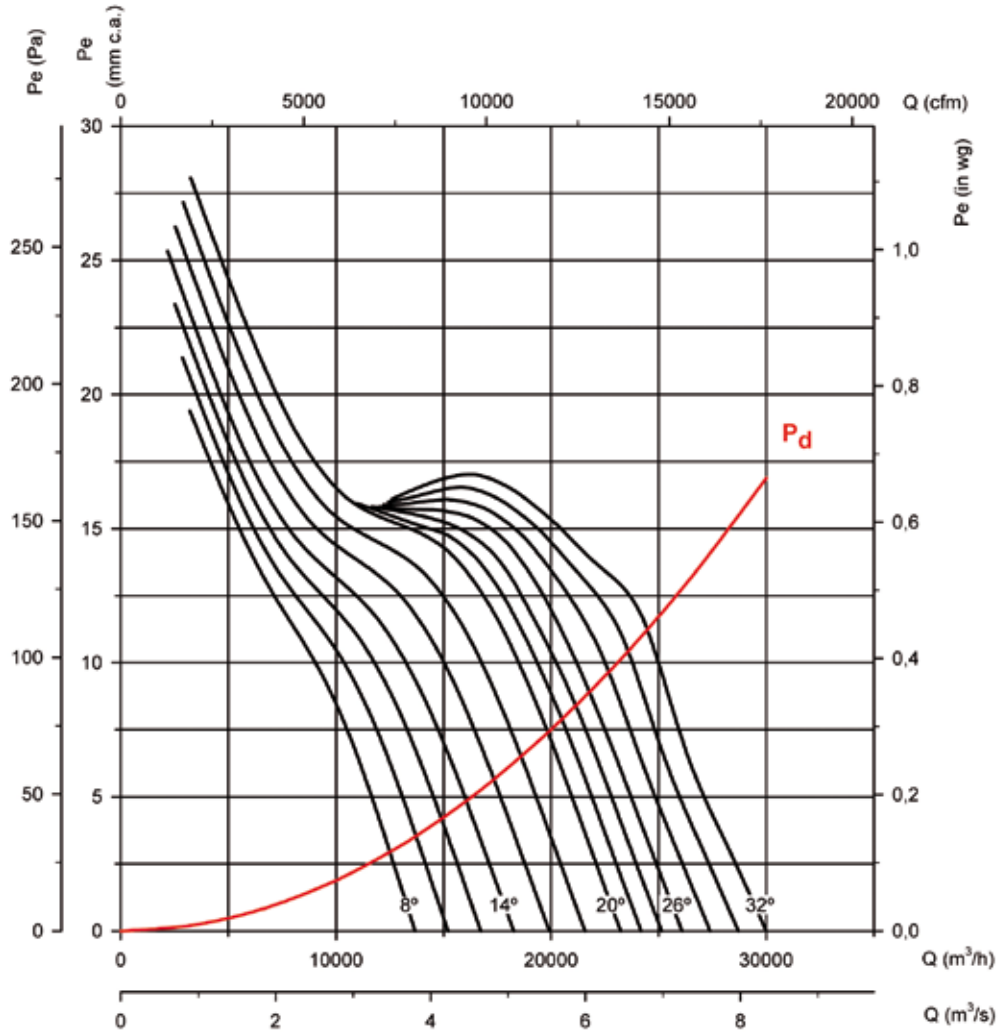

**Absorbed power**

**Recommended motor power kW (CV)**

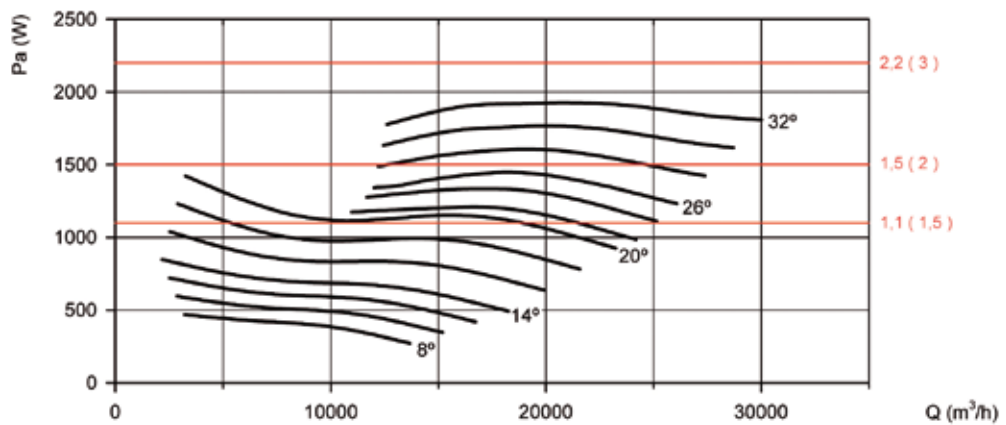

# THT CJTHT/PLUS CJTHT CJTHT/DUPLEX/ATEX

## Characteristic curves

THT CJTHT/PLUS CJTHT CJTHT/DUPLEX/ATEX

Q = Airflow in m<sup>3</sup>/h, m<sup>3</sup>/s and cfm.

Pe = Static pressure in mm.w.c., Pa and inwg.

Impeller diameter (cm): 80

Number of poles: 8

Number of blades: 6

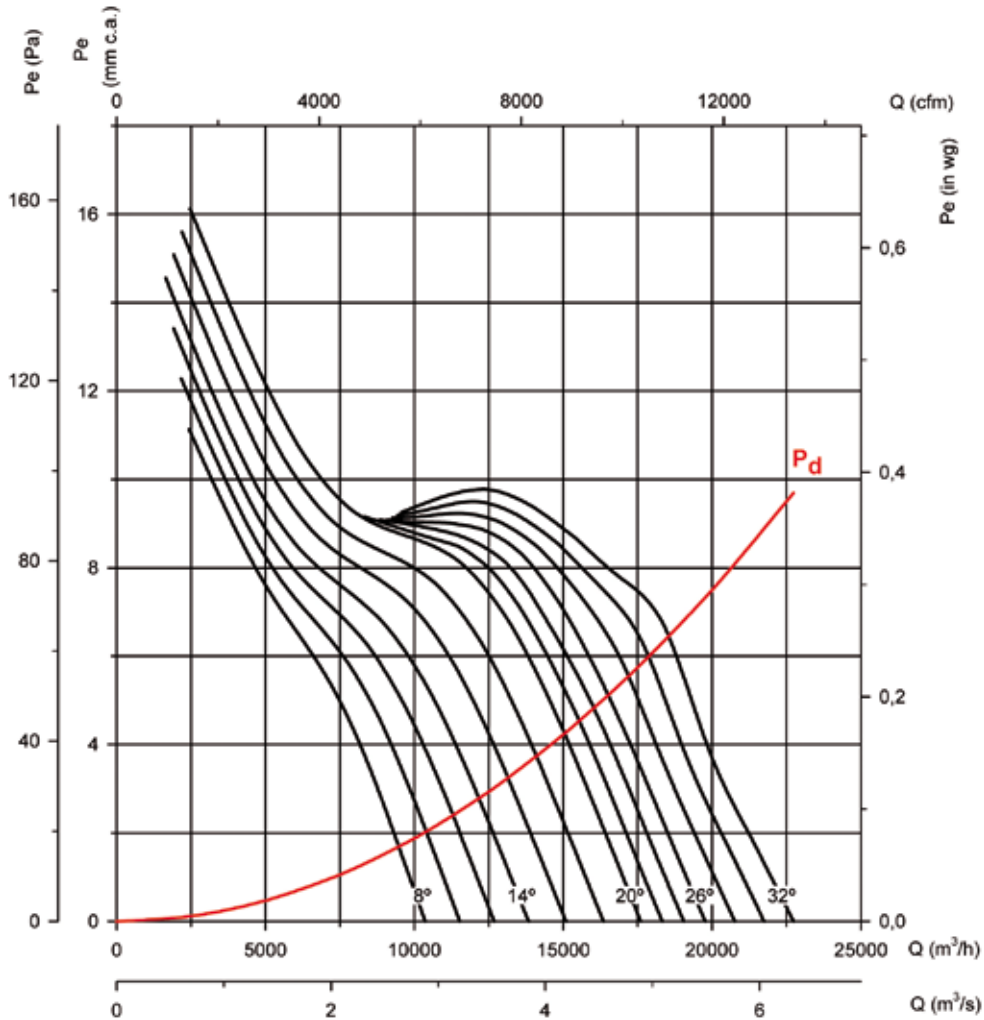

Absorbed power

Recommended motor power kW (CV)

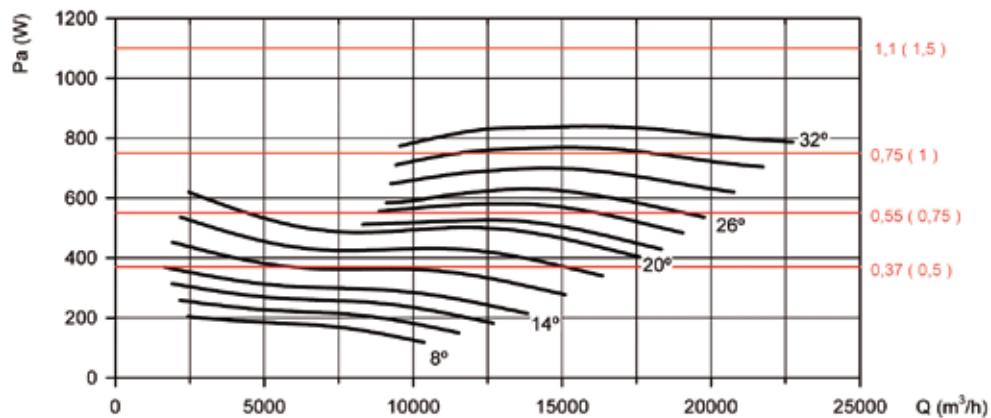

**Characteristic curves**

THT CJTHT/PLUS CJTHT CJTHT/DUPLEX/ATEX

Q = Airflow in m<sup>3</sup>/h, m<sup>3</sup>/s and cfm.

Pe = Static pressure in mm.w.c., Pa and inwg.

**Impeller diameter (cm): 90**

**Number of poles: 4**

**Number of blades: 6**

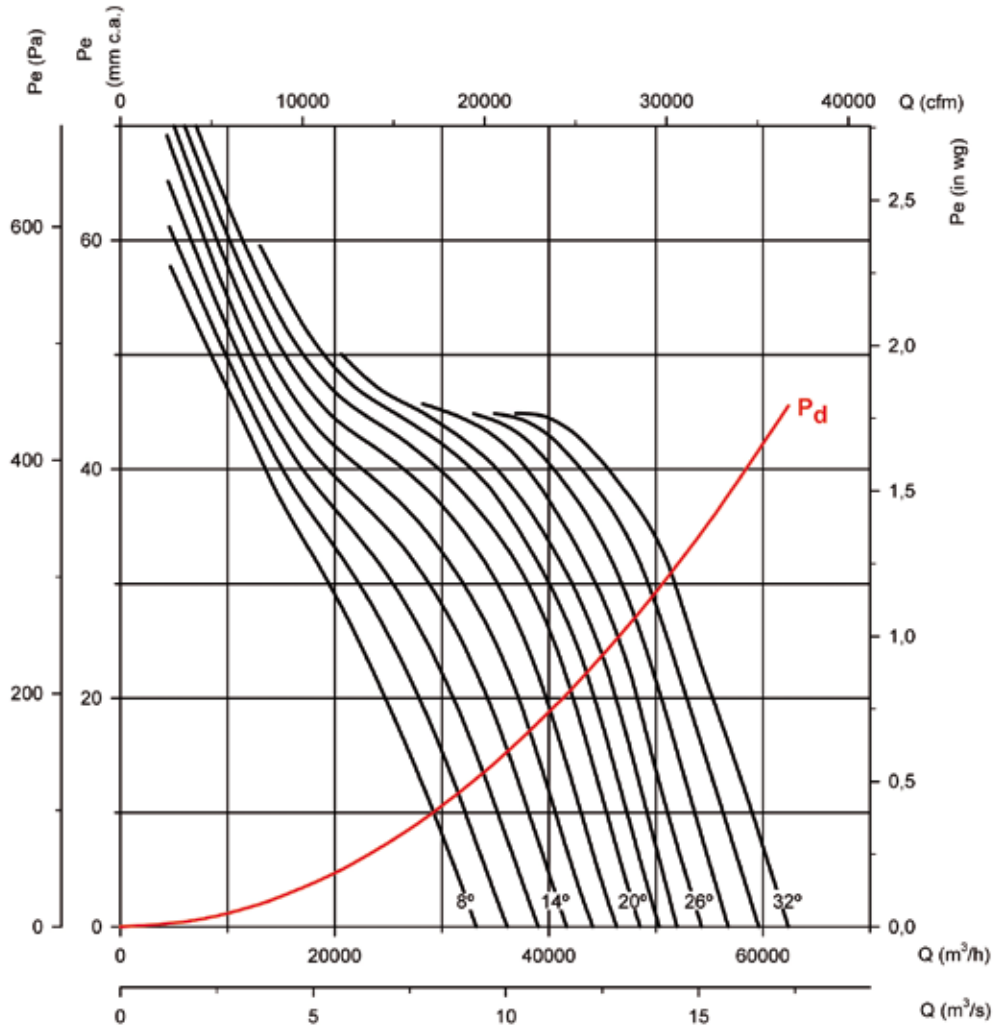

**Absorbed power**

**Recommended motor power kW (CV)**

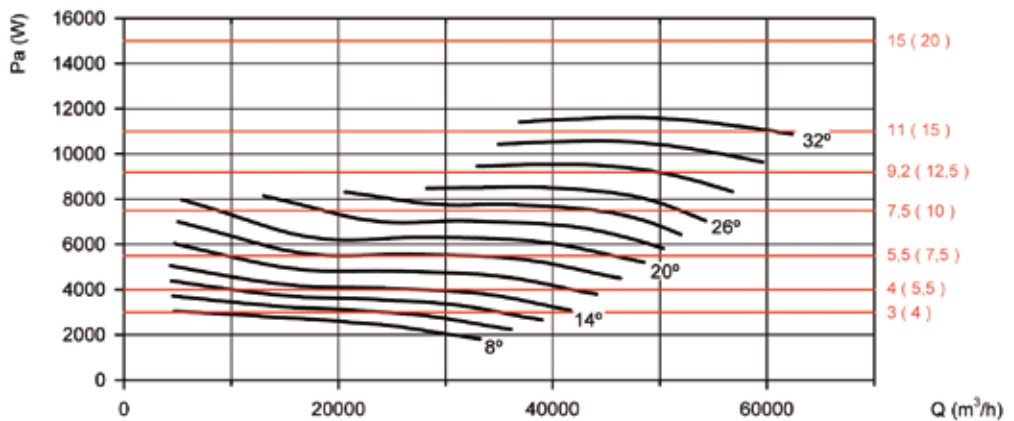

# THT CJTHT/PLUS CJTHT CJTHT/DUPLEX/ATEX

## Characteristic curves

THT CJTHT/PLUS CJTHT CJTHT/DUPLEX/ATEX

Q = Airflow in m<sup>3</sup>/h, m<sup>3</sup>/s and cfm.

Pe = Static pressure in mm.w.c., Pa and inwg.

Impeller diameter (cm): 90

Number of poles: 6

Number of blades: 6

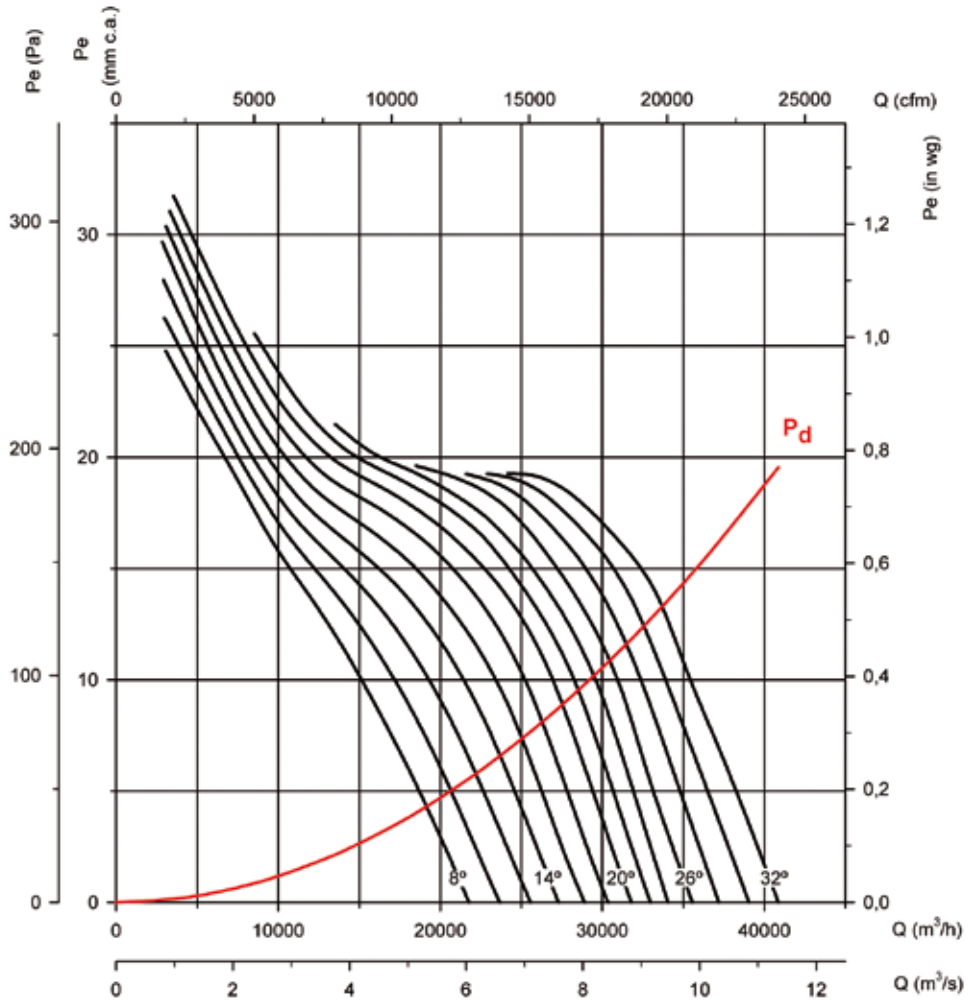

Absorbed power

Recommended motor power kW (CV)

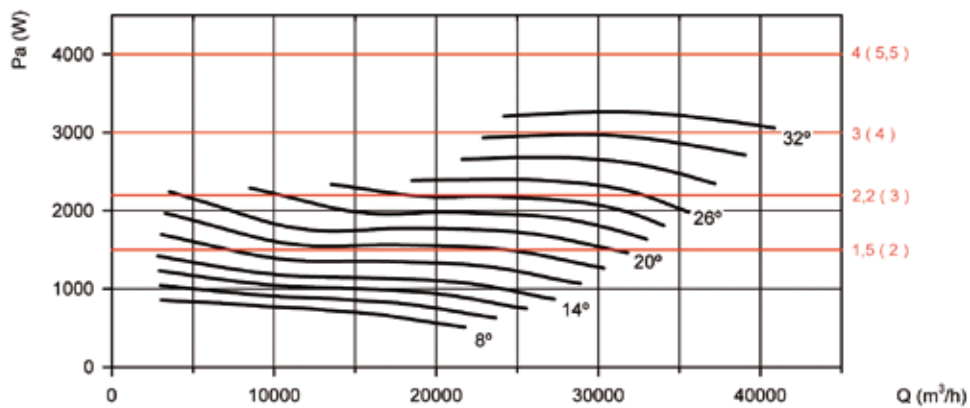

**Characteristic curves**

THT

CJTHT/PLUS

CJTHT

CJTHT/DUPLEX/ATEX

Q = Airflow in m<sup>3</sup>/h, m<sup>3</sup>/s and cfm.

Pe = Static pressure in mm.w.c., Pa and inwg.

**Impeller diameter (cm): 90**

**Number of poles: 8**

**Number of blades: 6**

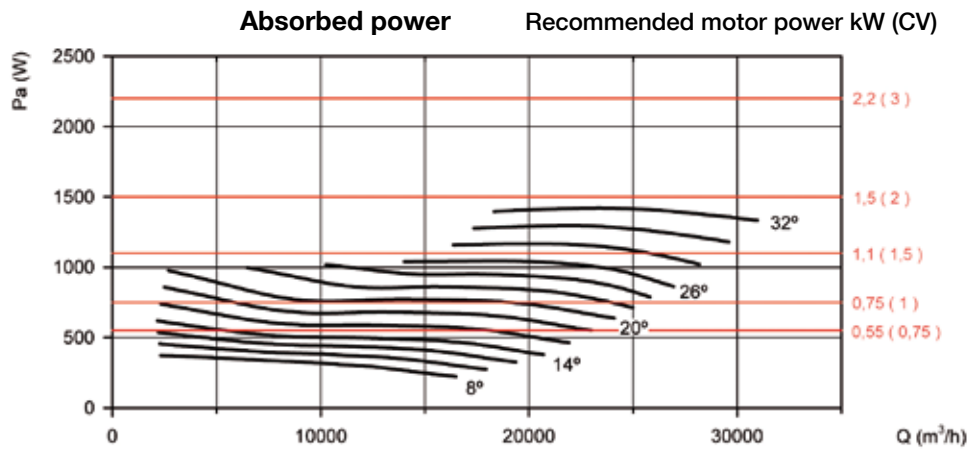
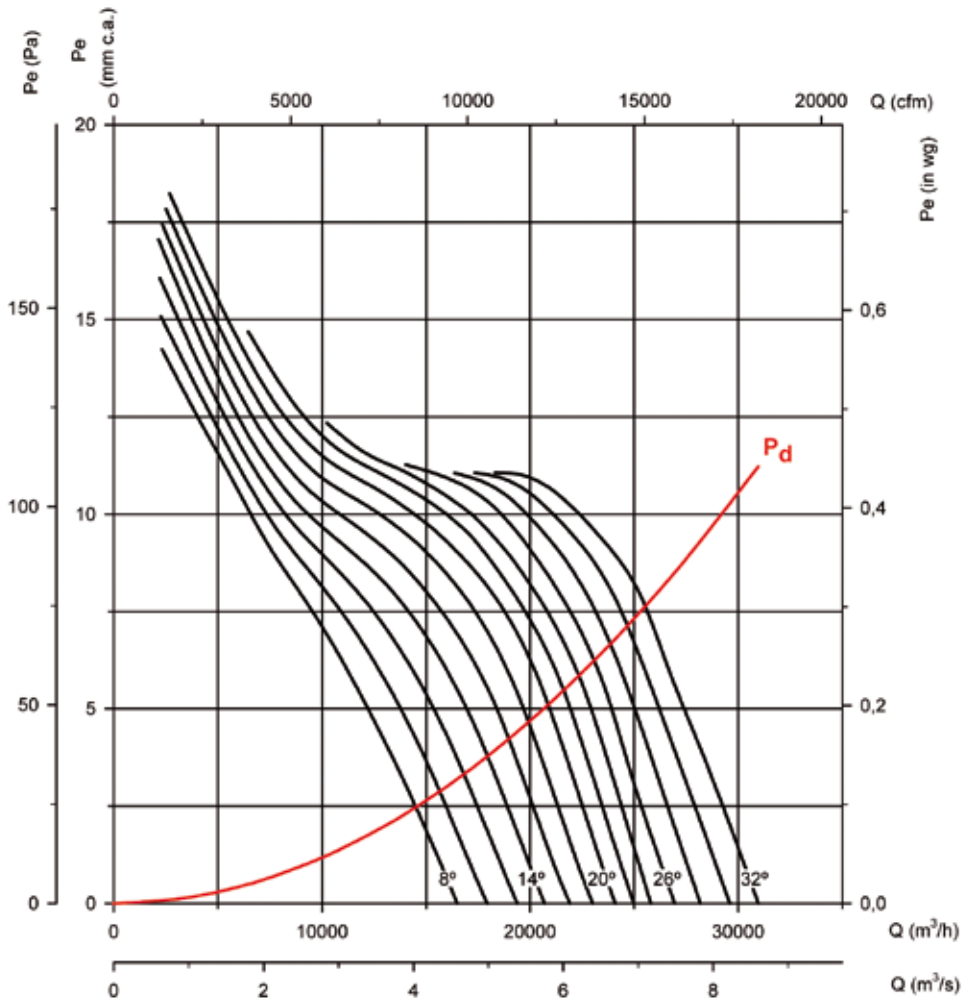

# THT CJTHT/PLUS CJTHT CJTHT/DUPLEX/ATEX

## Characteristic curves

THT CJTHT/PLUS CJTHT CJTHT/DUPLEX/ATEX

Q = Airflow in m<sup>3</sup>/h, m<sup>3</sup>/s and cfm.

Pe = Static pressure in mm.w.c., Pa and inwg.

**Impeller diameter (cm): 100    Number of poles: 4    Number of blades: 6**

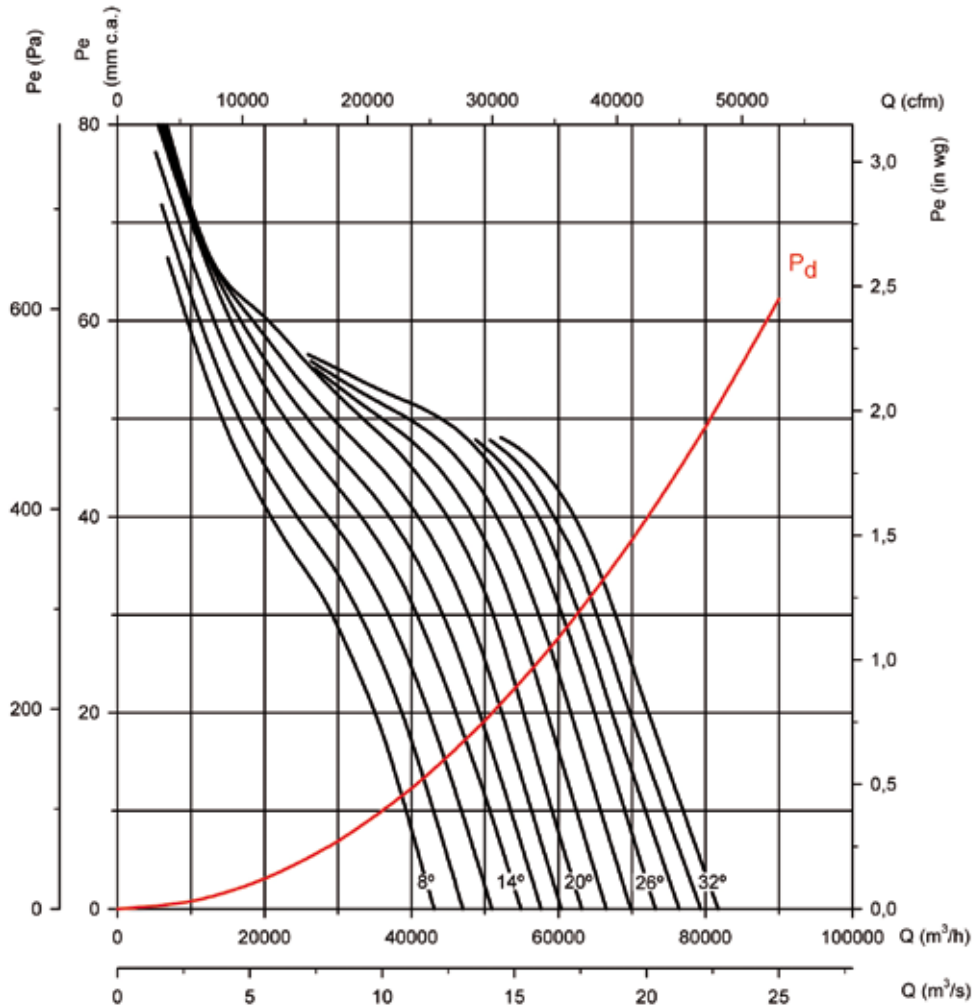

Absorbed power

Recommended motor power kW (CV)

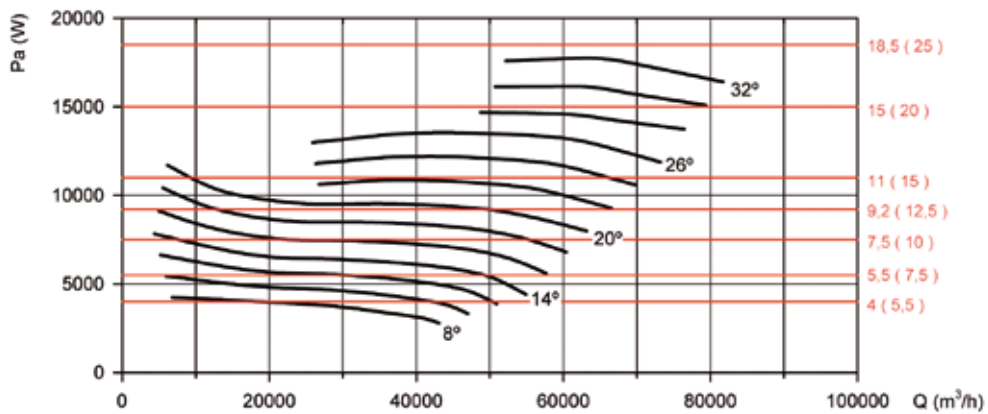

**Characteristic curves**

THT CJTHT/PLUS CJTHT CJTHT/DUPLEX/ATEX

Q = Airflow in m<sup>3</sup>/h, m<sup>3</sup>/s and cfm.

Pe = Static pressure in mm.w.c., Pa and inwg.

**Impeller diameter (cm): 100    Number of poles: 6    Number of blades: 6**

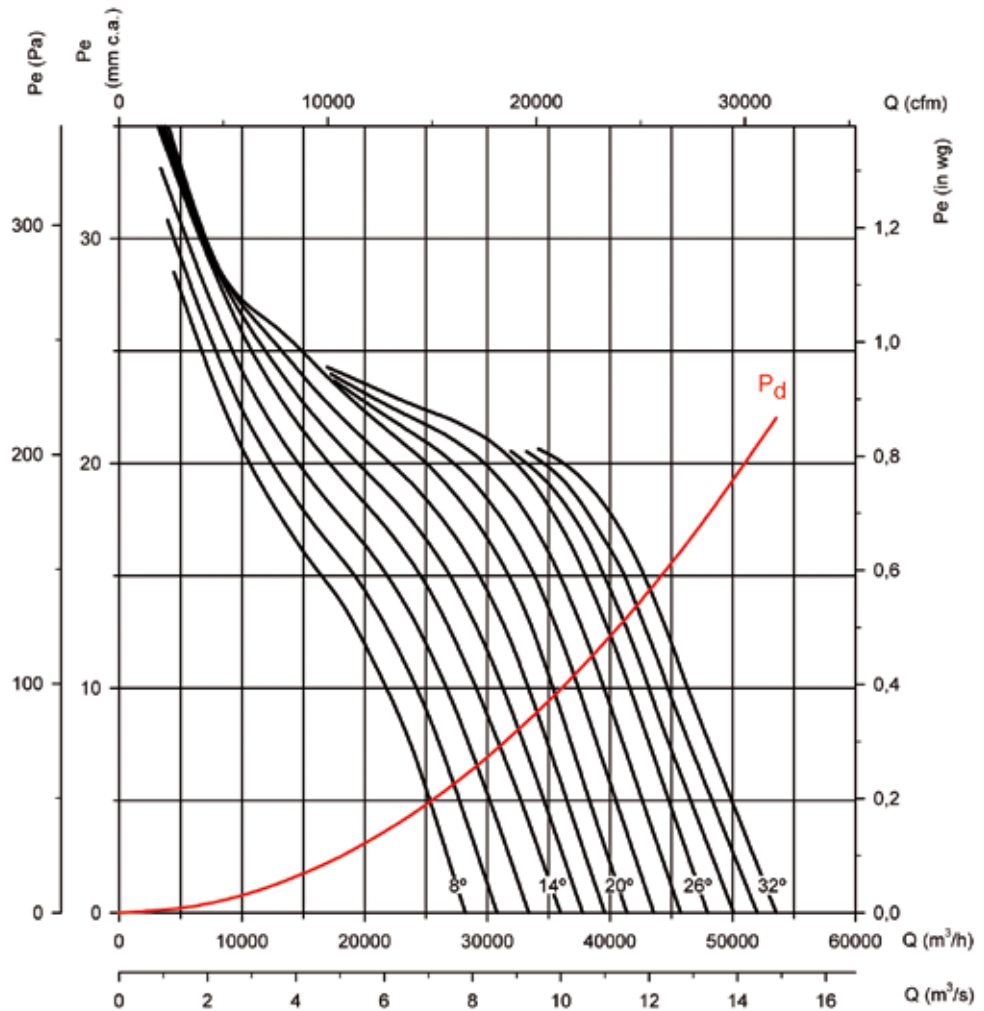

**Absorbed power      Recommended motor power kW (CV)**

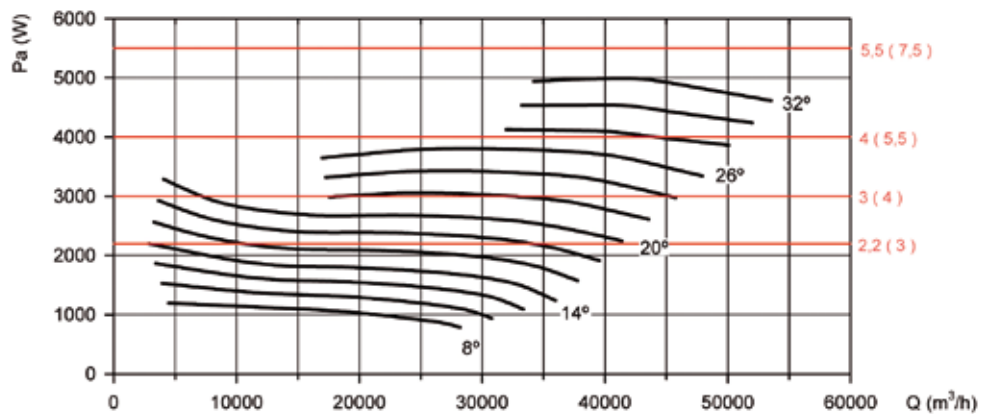

# THT CJTHT/PLUS CJTHT CJTHT/DUPLEX/ATEX

## Characteristic curves

THT CJTHT/PLUS CJTHT CJTHT/DUPLEX/ATEX

Q = Airflow in m<sup>3</sup>/h, m<sup>3</sup>/s and cfm.

Pe = Static pressure in mm.w.c., Pa and inwg.

**Impeller diameter (cm): 100    Number of poles: 8    Number of blades: 6**

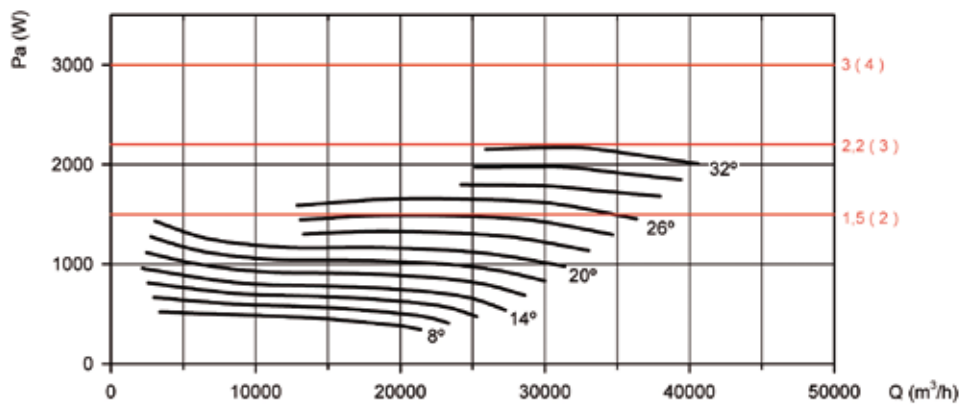
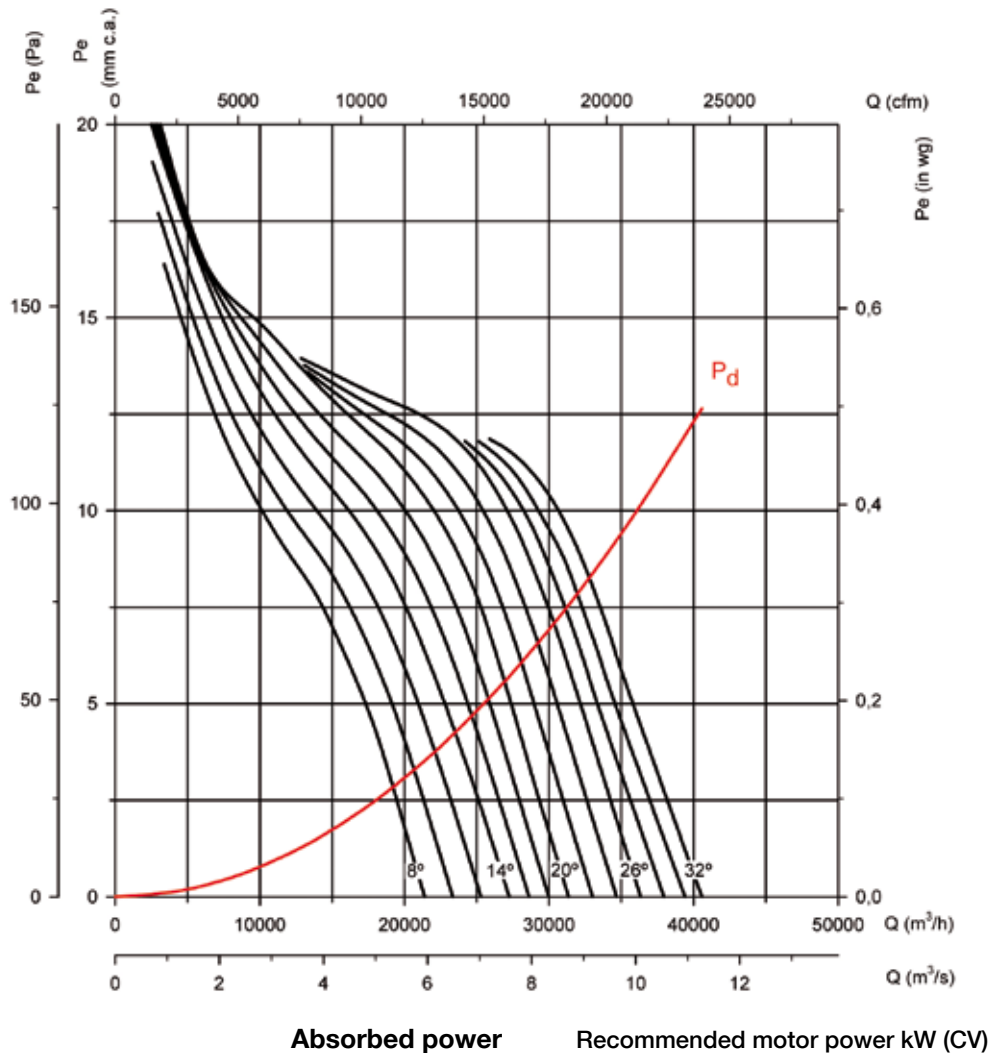

Characteristic curves

THT CJTHT/PLUS CJTHT CJTHT/DUPLEX/ATEX

Q = Airflow in m<sup>3</sup>/h, m<sup>3</sup>/s and cfm.

Pe = Static pressure in mm.w.c., Pa and inwg.

**Impeller diameter (cm): 125    Number of poles: 4    Number of blades: 3**

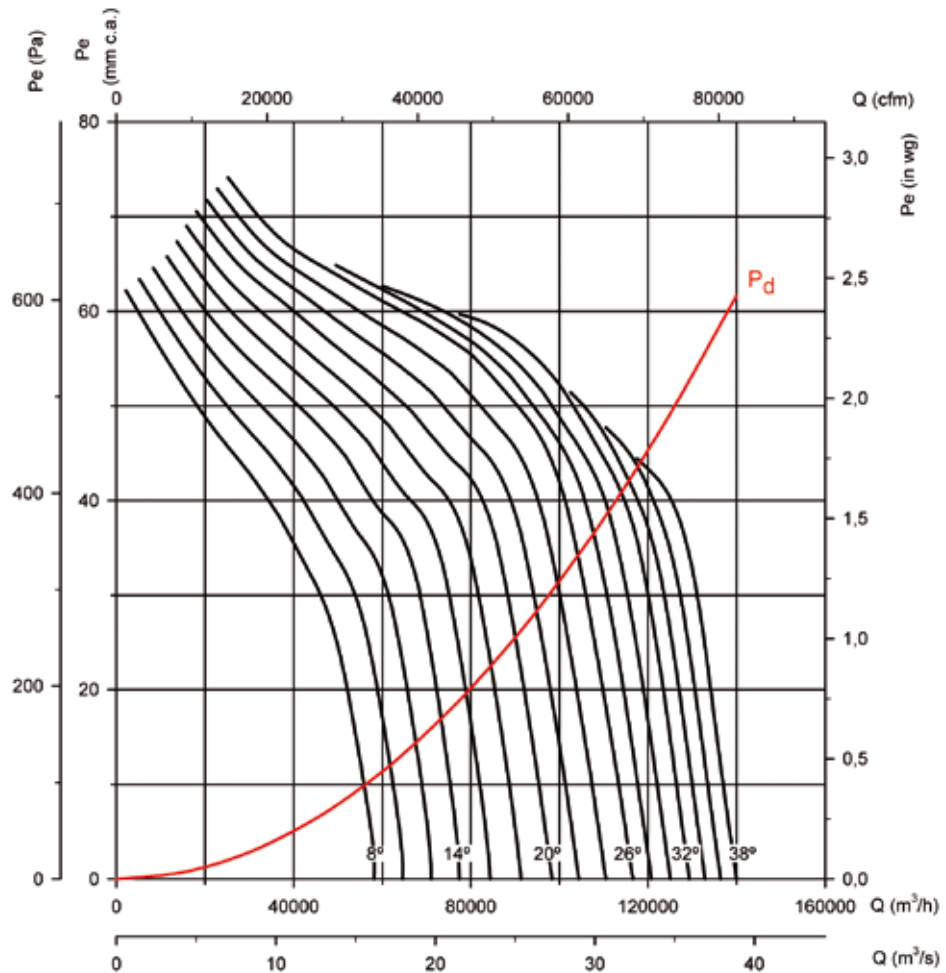

Absorbed power

Recommended motor power kW (CV)

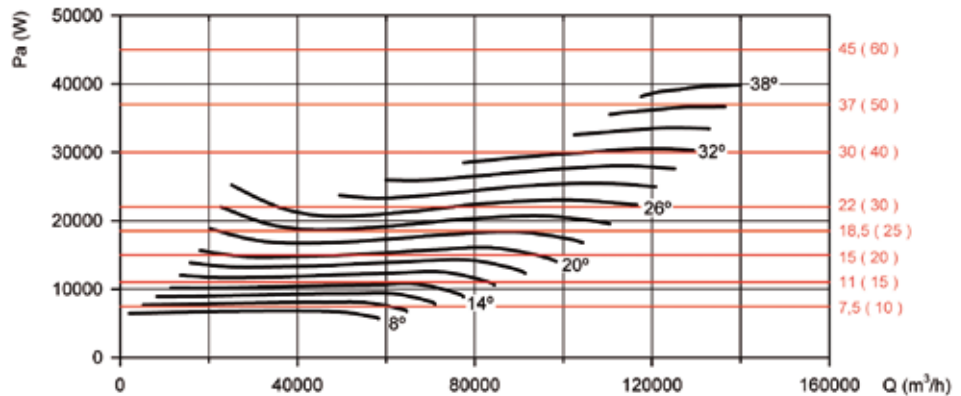

# THT CJTHT/PLUS CJTHT CJTHT/DUPLEX/ATEX

## Characteristic curves

THT CJTHT/PLUS CJTHT CJTHT/DUPLEX/ATEX

Q = Airflow in m<sup>3</sup>/h, m<sup>3</sup>/s and cfm.

Pe = Static pressure in mm.w.c., Pa and inwg.

**Impeller diameter (cm): 125    Number of poles: 4    Number of blades: 6**

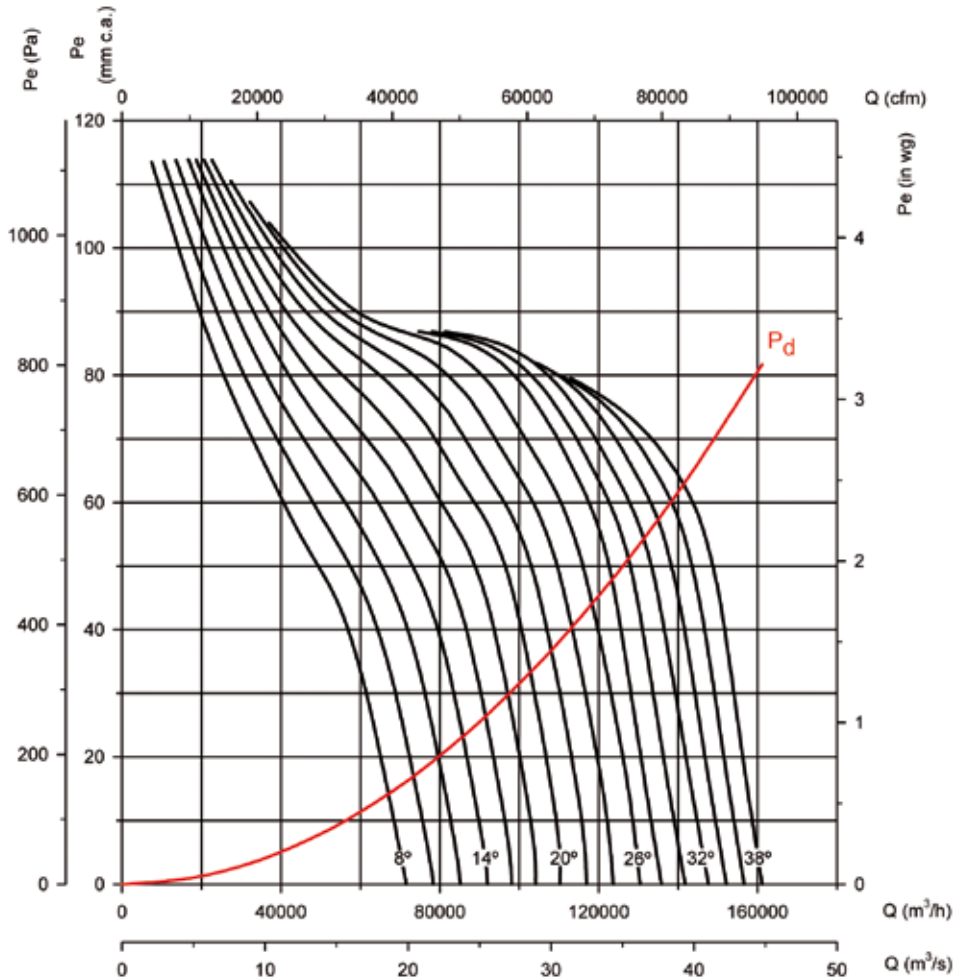

Absorbed power

Recommended motor power kW (CV)

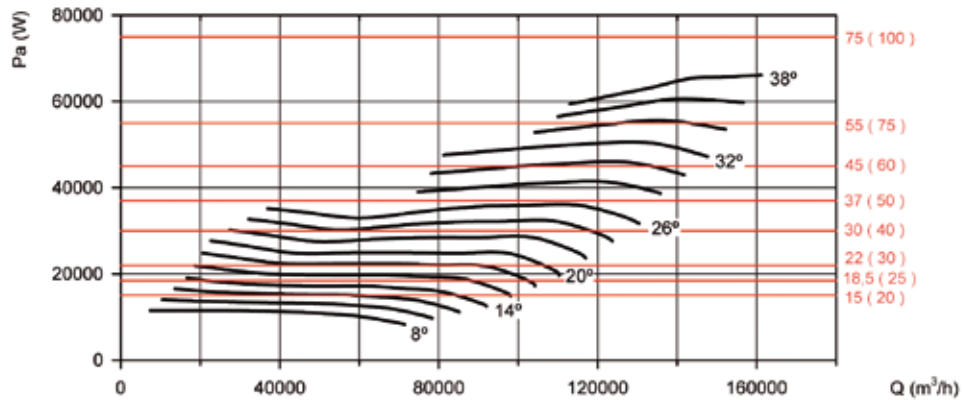

**Characteristic curves**

THT CJTHT/PLUS CJTHT CJTHT/DUPLEX/ATEX

Q = Airflow in m<sup>3</sup>/h, m<sup>3</sup>/s and cfm.

Pe = Static pressure in mm.w.c., Pa and inwg.

**Impeller diameter (cm): 125    Number of poles: 4    Number of blades: 9**

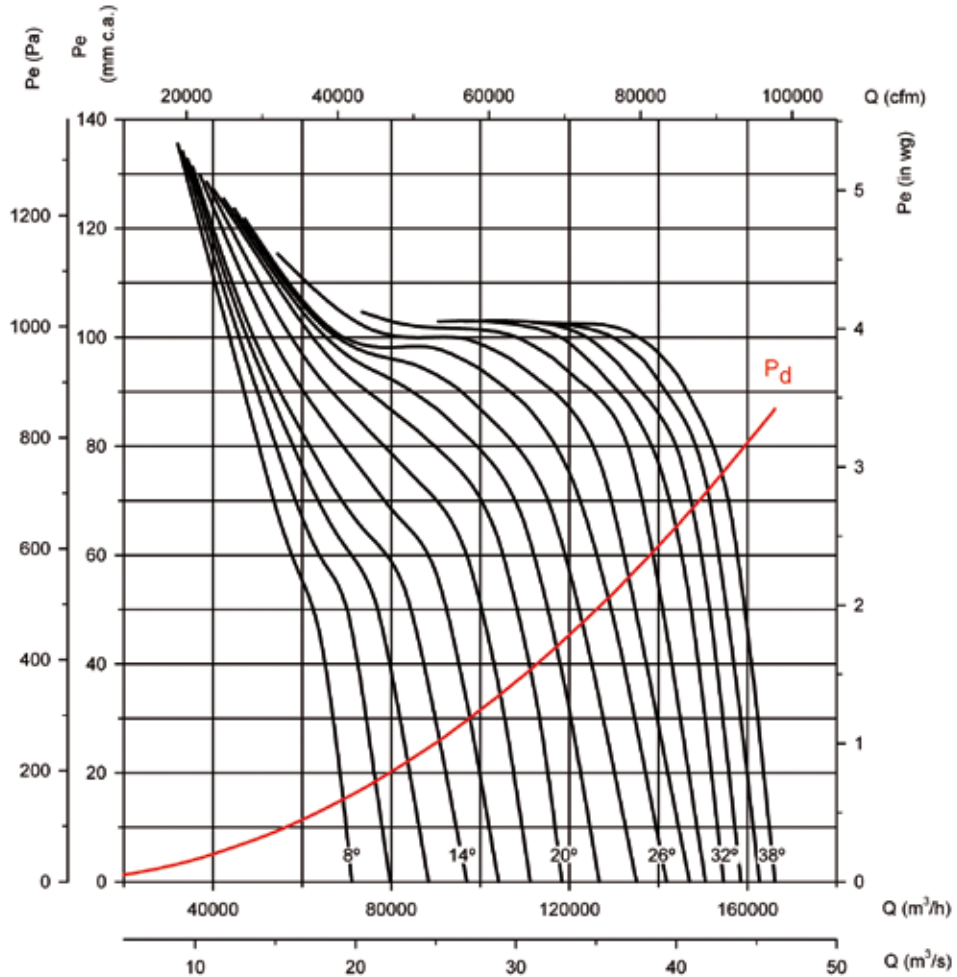

**Absorbed power**

**Recommended motor power kW (CV)**

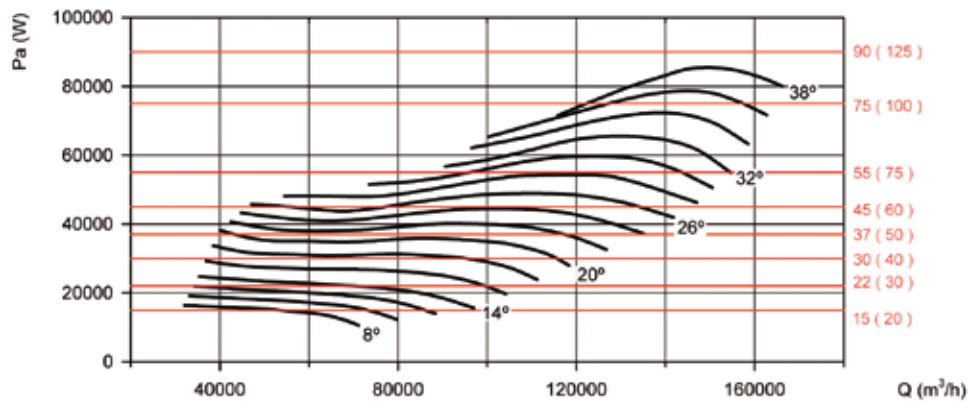

# THT CJTHT/PLUS CJTHT CJTHT/DUPLEX/ATEX

## Characteristic curves

THT CJTHT/PLUS CJTHT CJTHT/DUPLEX/ATEX

Q = Airflow in m<sup>3</sup>/h, m<sup>3</sup>/s and cfm.

Pe = Static pressure in mm.w.c., Pa and inwg.

**Impeller diameter (cm): 125    Number of poles: 6    Number of blades: 3**

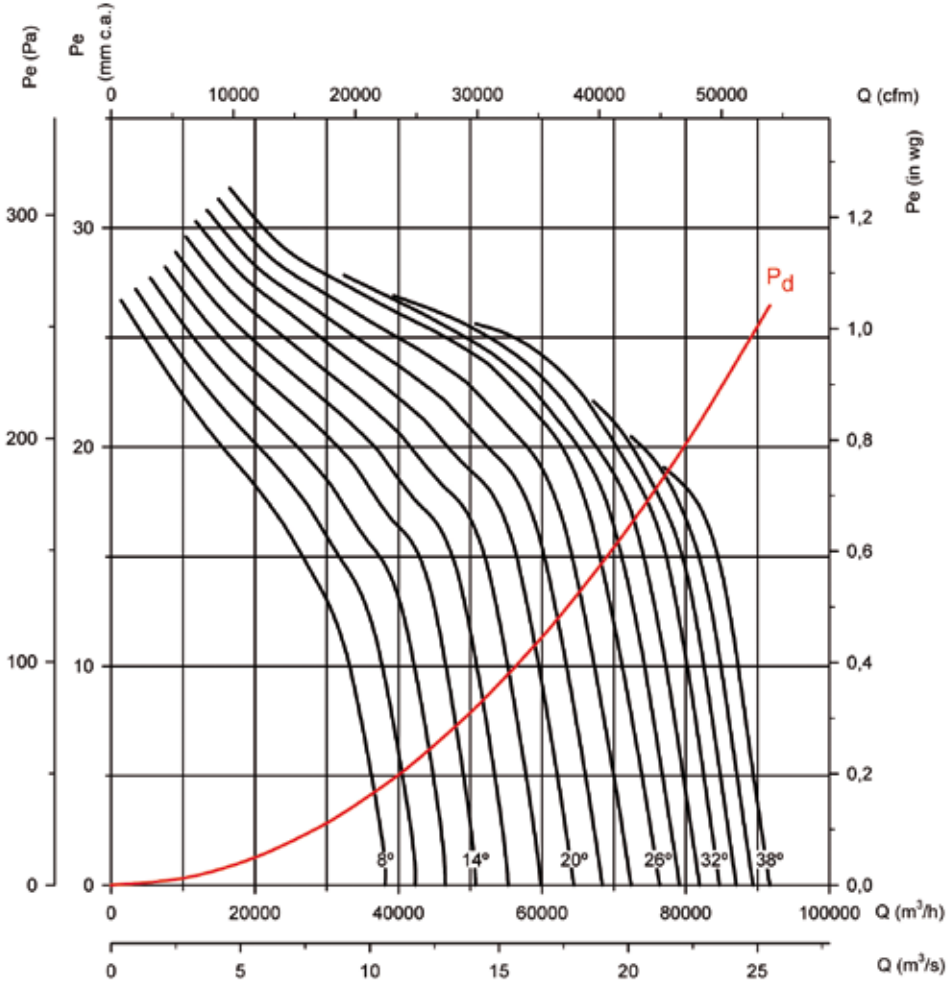

Absorbed power

Recommended motor power kW (CV)

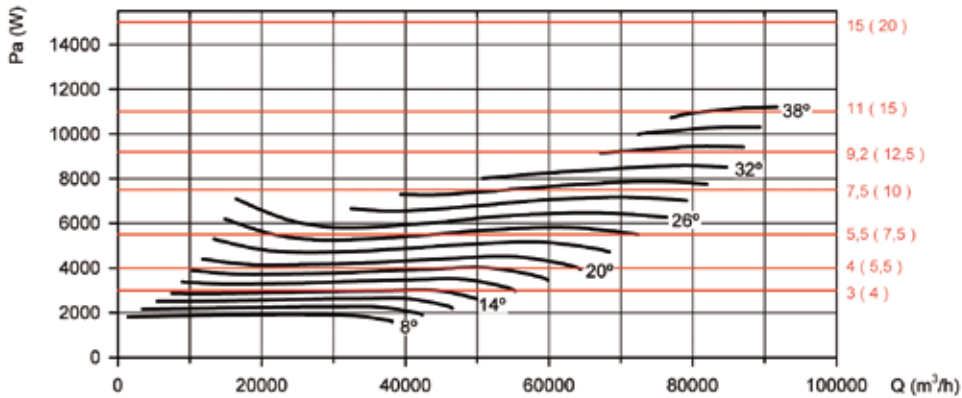

**Characteristic curves**

THT CJTHT/PLUS CJTHT CJTHT/DUPLEX/ATEX

Q = Airflow in m<sup>3</sup>/h, m<sup>3</sup>/s and cfm.

Pe = Static pressure in mm.w.c., Pa and inwg.

**Impeller diameter (cm): 125    Number of poles: 6    Number of blades: 6**

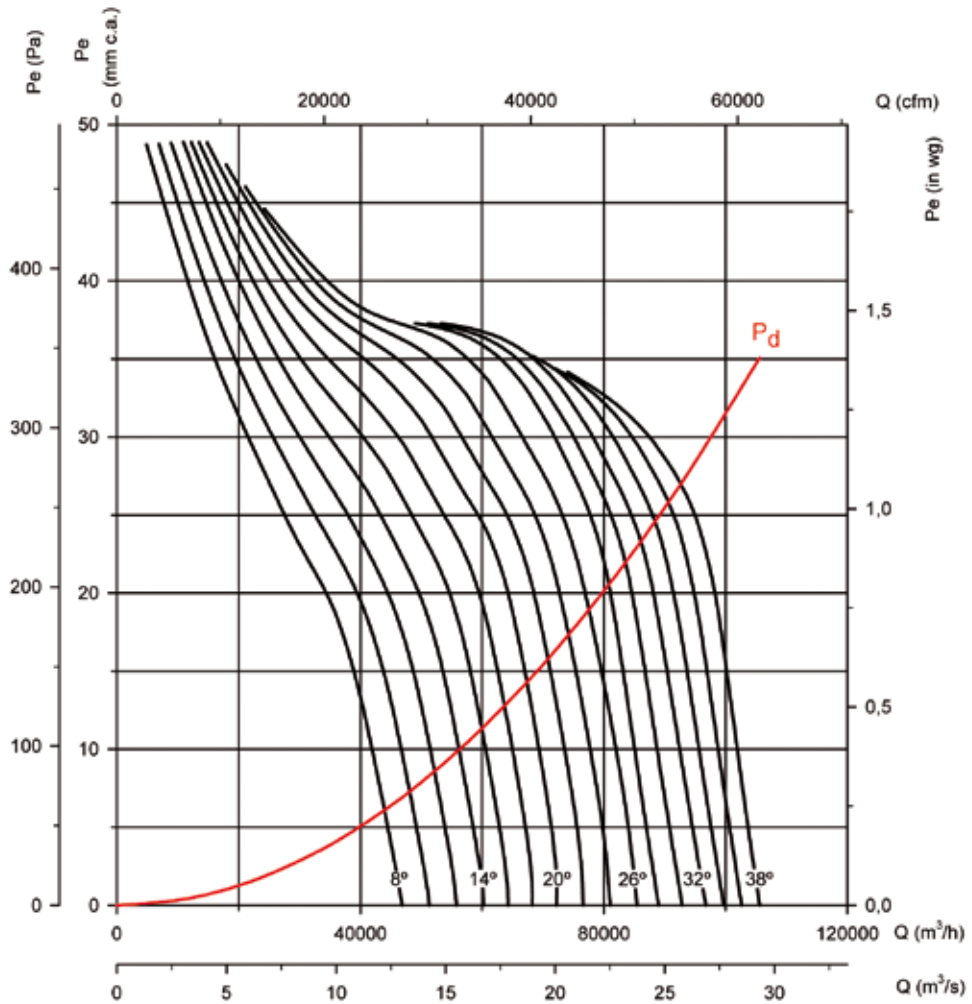

**Absorbed power**

**Recommended motor power kW (CV)**

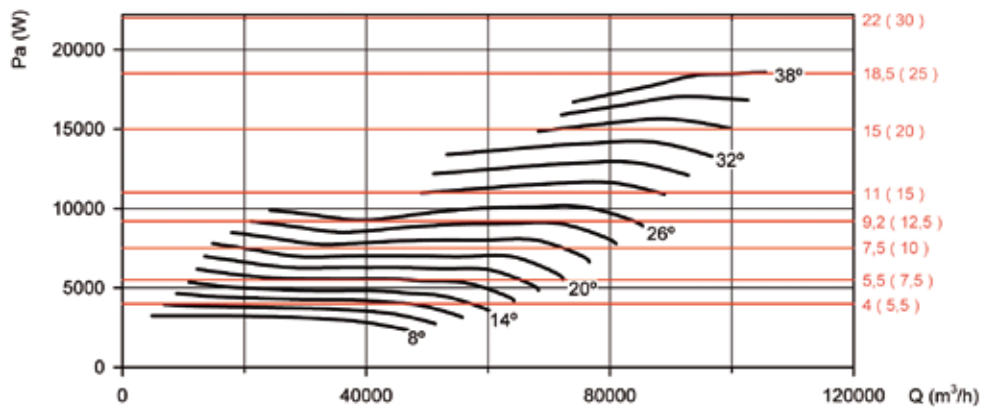

# THT CJTHT/PLUS CJTHT CJTHT/DUPLEX/ATEX

## Characteristic curves

THT CJTHT/PLUS CJTHT CJTHT/DUPLEX/ATEX

Q = Airflow in m<sup>3</sup>/h, m<sup>3</sup>/s and cfm.

Pe = Static pressure in mm.w.c., Pa and inwg.

**Impeller diameter (cm): 125    Number of poles: 6    Number of blades: 9**

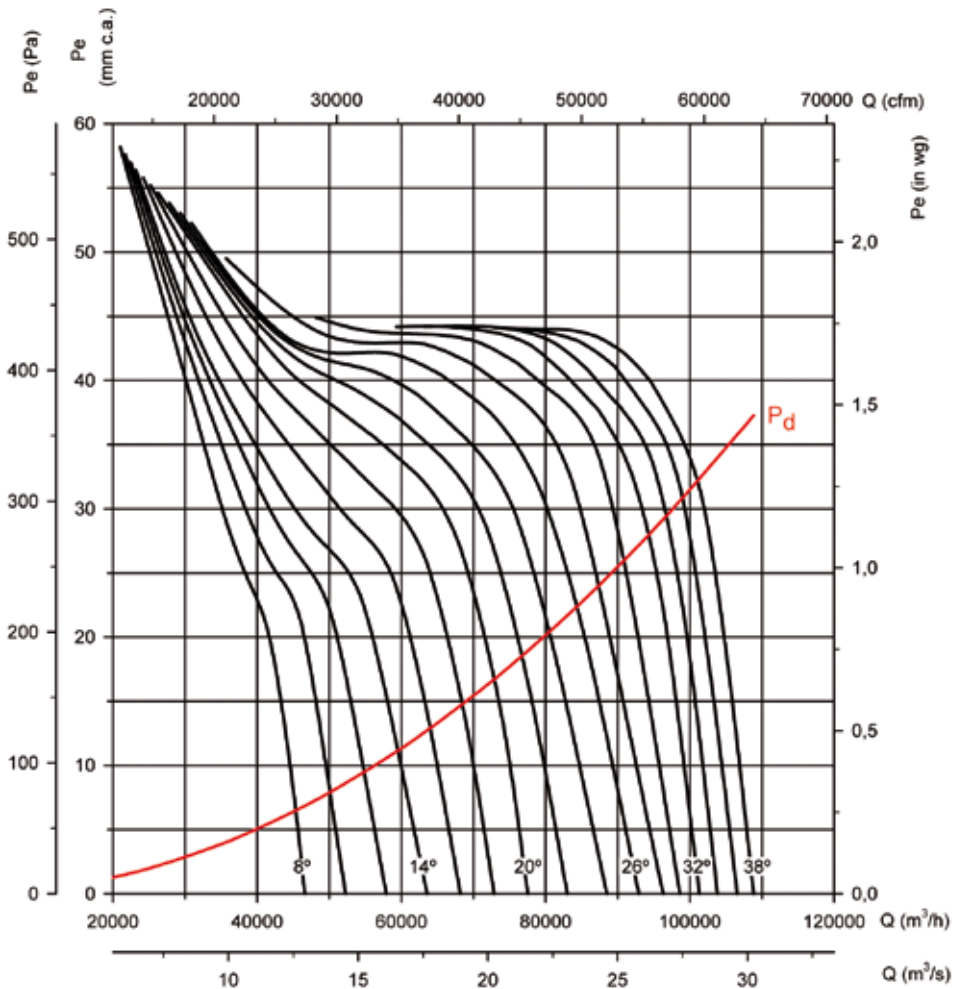

### Absorbed power

### Recommended motor power kW (CV)

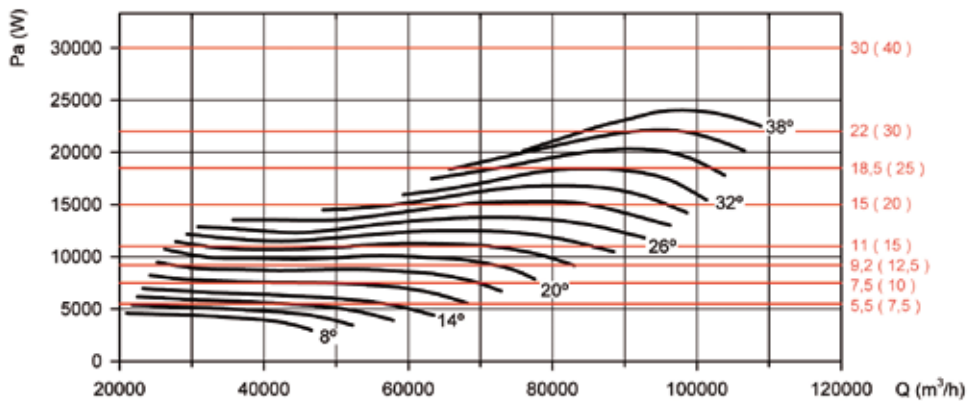

**Characteristic curves**

Q = Airflow in m<sup>3</sup>/h, m<sup>3</sup>/s and cfm.

Pe = Static pressure in mm.w.c., Pa and inwg.

**Impeller diameter (cm): 140    Number of poles: 6    Number of blades: 3**

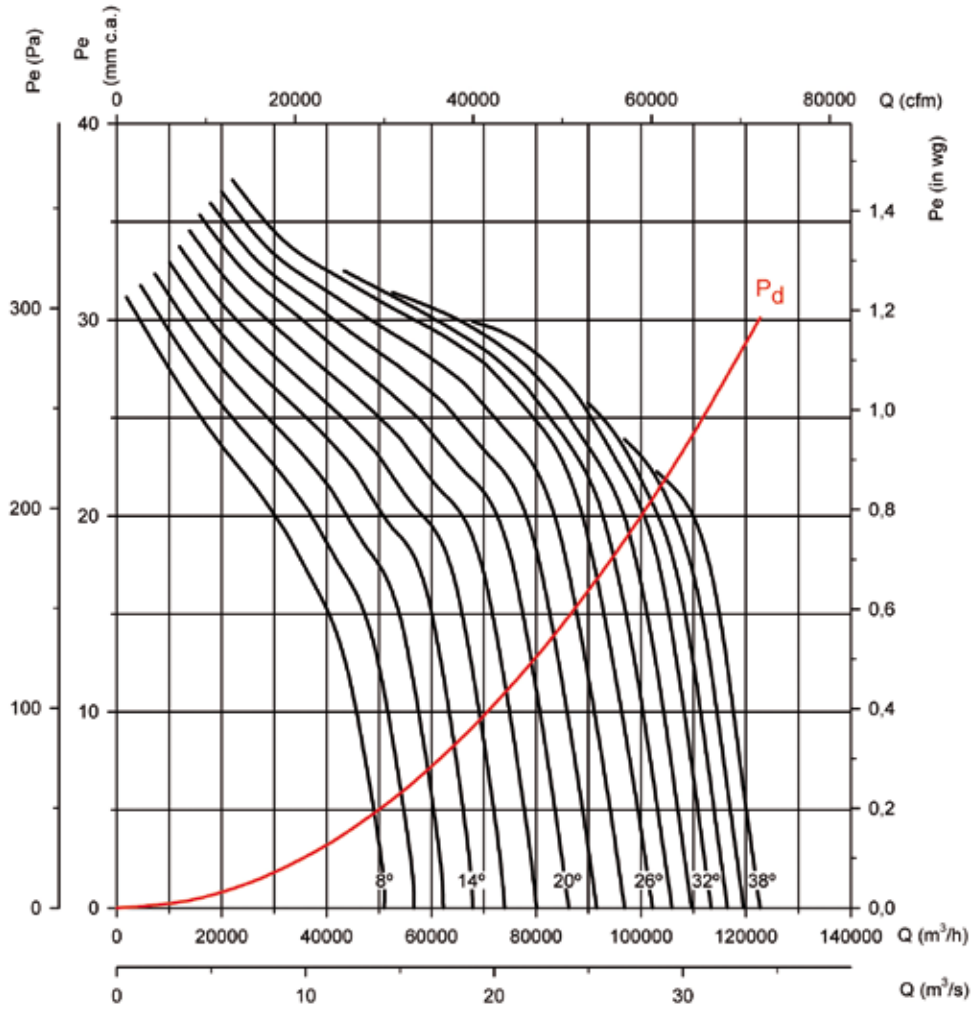

**Absorbed power**

**Recommended motor power kW (CV)**

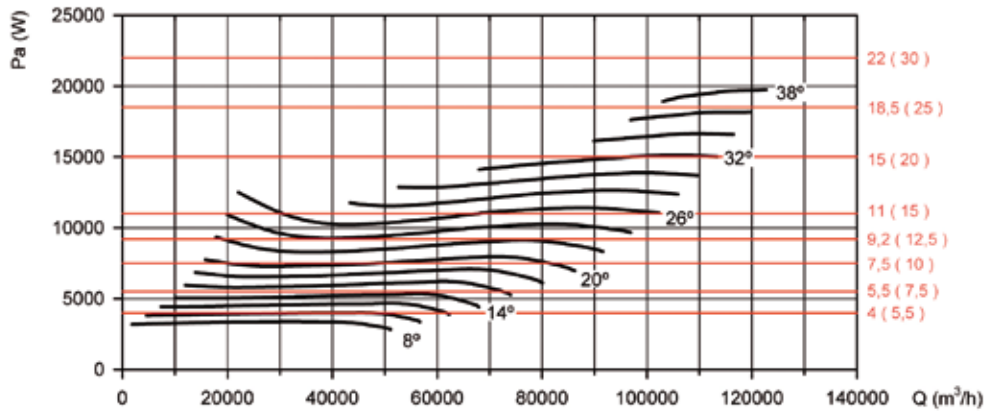

# THT CJTHT/PLUS CJTHT CJTHT/DUPLEX/ATEX

## Characteristic curves

THT CJTHT/PLUS CJTHT CJTHT/DUPLEX/ATEX

Q = Airflow in m<sup>3</sup>/h, m<sup>3</sup>/s and cfm.

Pe = Static pressure in mm.w.c., Pa and inwg.

**Impeller diameter (cm): 140    Number of poles: 6    Number of blades: 6**

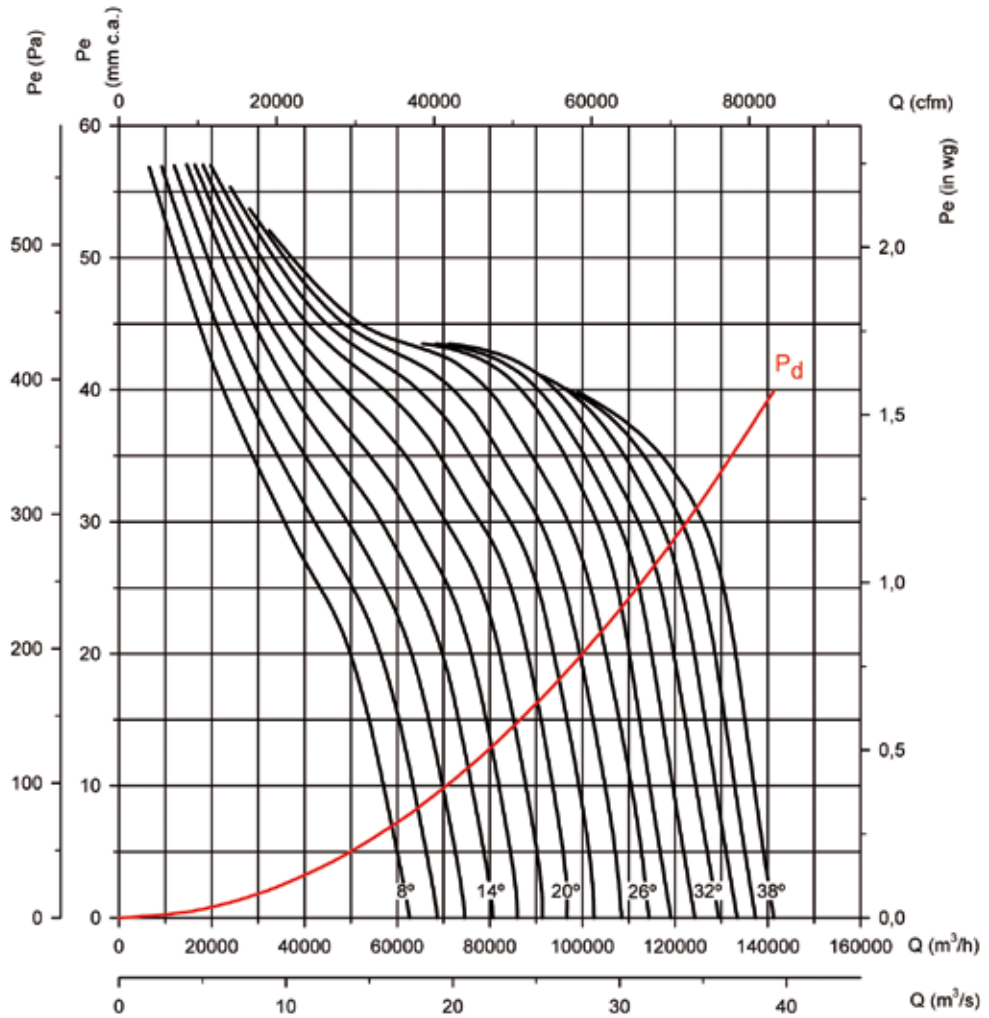

Absorbed power

Recommended motor power kW (CV)

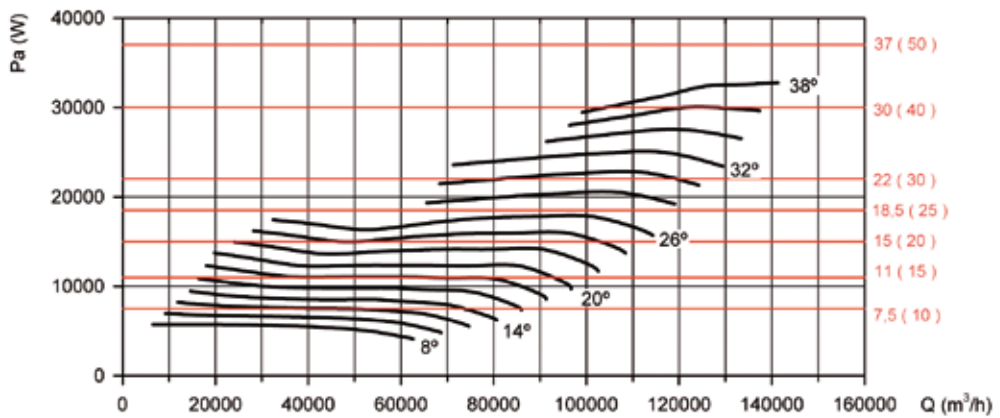

**Characteristic curves**

THT CJTHT/PLUS CJTHT CJTHT/DUPLEX/ATEX

Q = Airflow in m<sup>3</sup>/h, m<sup>3</sup>/s and cfm.

Pe = Static pressure in mm.w.c., Pa and inwg.

**Impeller diameter (cm): 140    Number of poles: 6    Number of blades: 9**

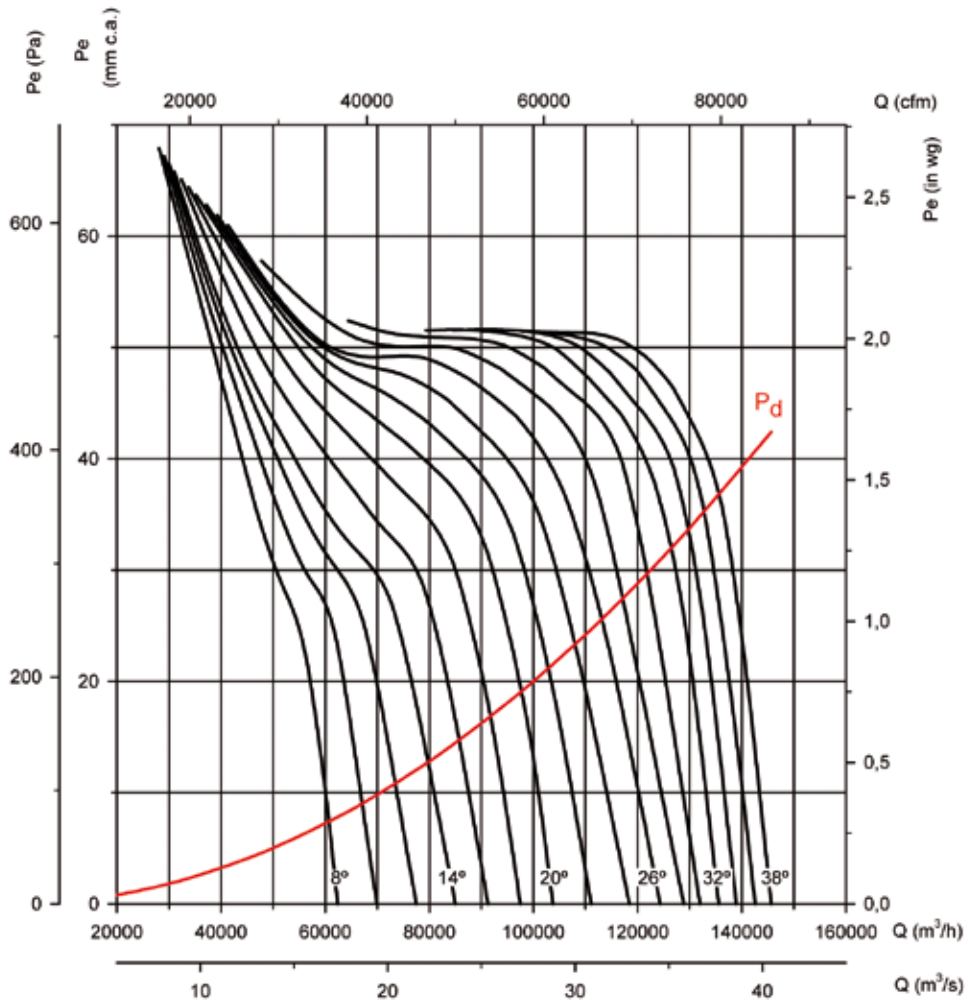

**Absorbed power**

**Recommended motor power kW (CV)**

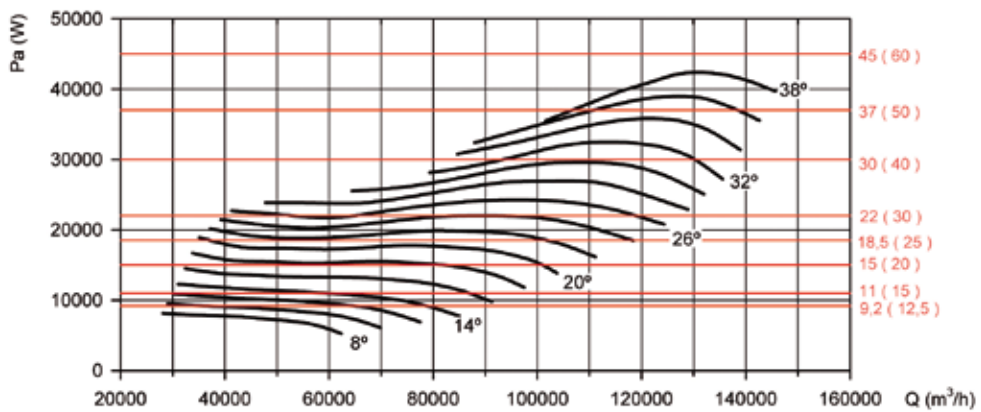

# THT CJTHT/PLUS CJTHT CJTHT/DUPLEX/ATEX

## Characteristic curves

THT CJTHT/PLUS CJTHT CJTHT/DUPLEX/ATEX

Q = Airflow in m<sup>3</sup>/h, m<sup>3</sup>/s and cfm.

Pe = Static pressure in mm.w.c., Pa and inwg.

**Impeller diameter (cm): 140    Number of poles: 8    Number of blades: 3**

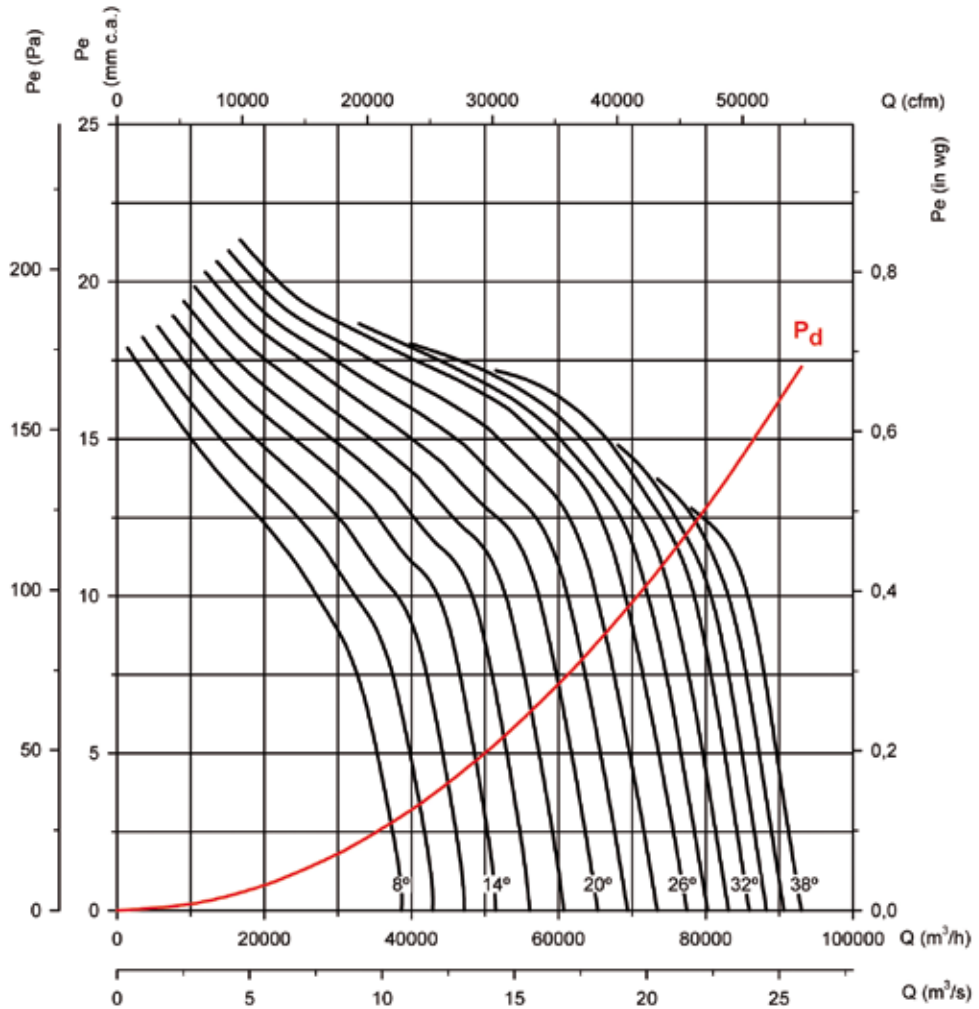

**Absorbed power    Recommended motor power kW (CV)**

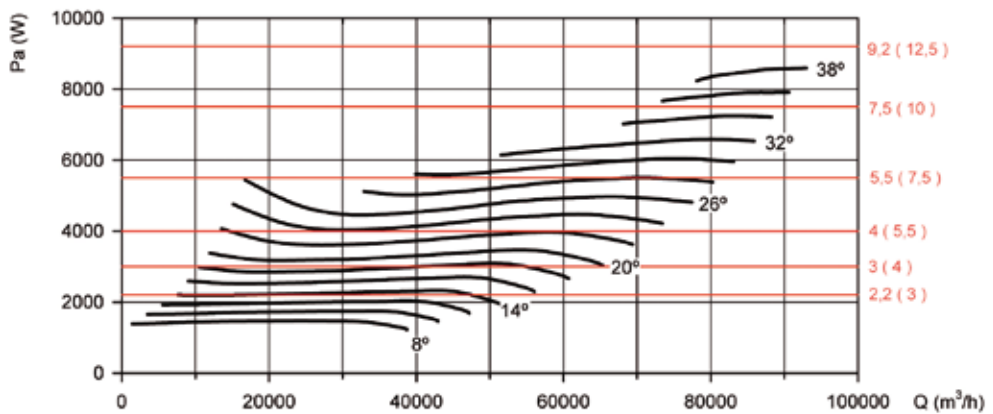

**Characteristic curves**

THT CJTHT/PLUS CJTHT CJTHT/DUPLEX/ATEX

Q = Airflow in m<sup>3</sup>/h, m<sup>3</sup>/s and cfm.

Pe = Static pressure in mm.w.c., Pa and inwg.

**Impeller diameter (cm): 140    Number of poles: 8    Number of blades: 6**

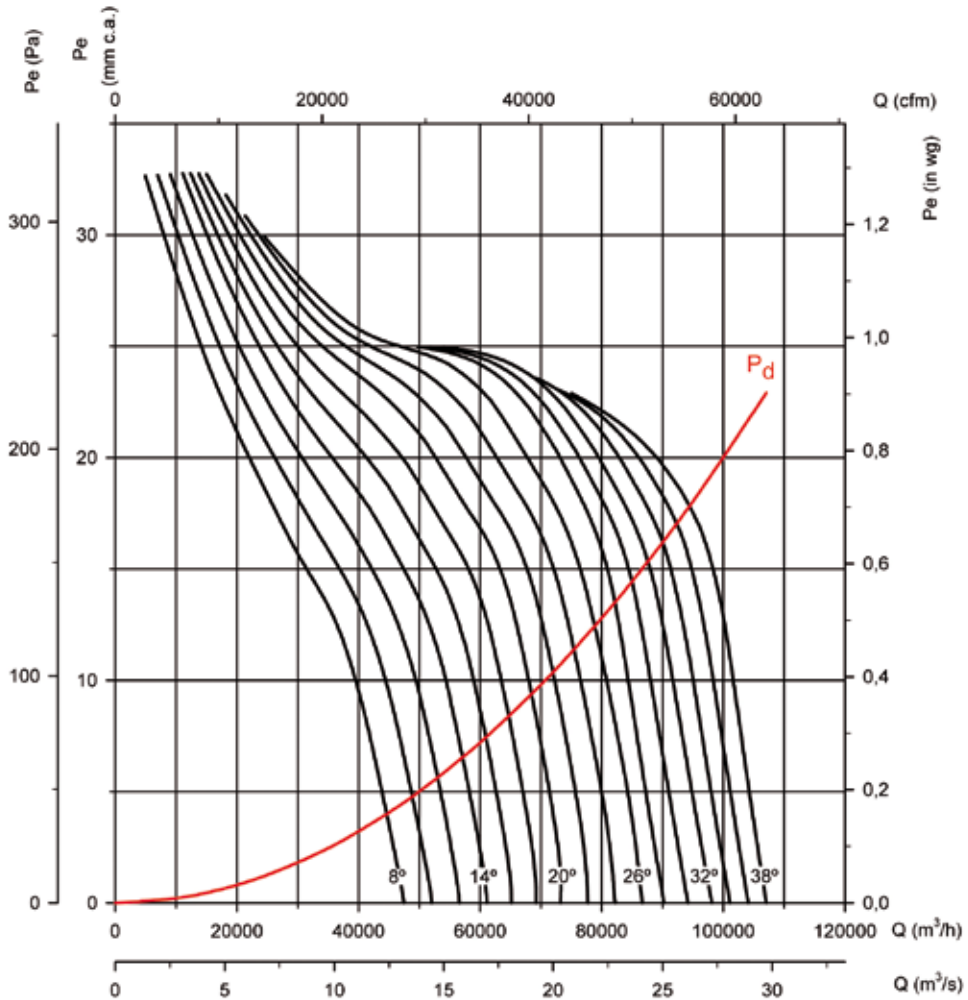

**Absorbed power**

**Recommended motor power kW (CV)**

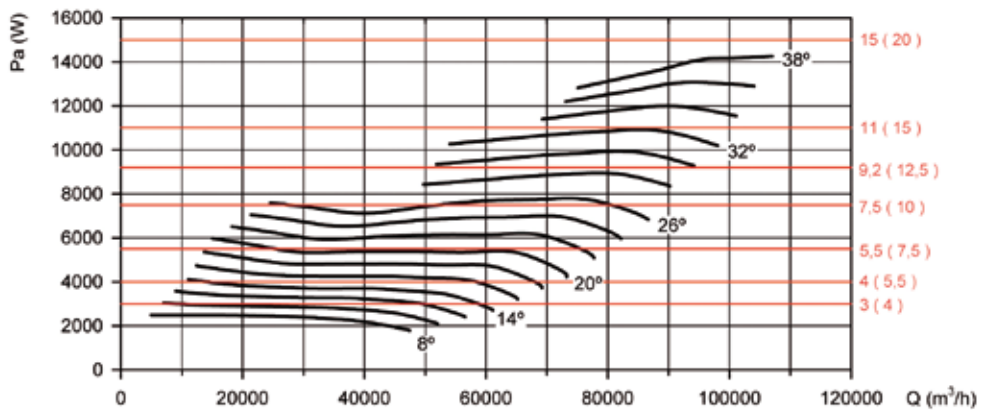

# THT CJTHT/PLUS CJTHT CJTHT/DUPLEX/ATEX

## Characteristic curves

THT CJTHT/PLUS CJTHT CJTHT/DUPLEX/ATEX

Q = Airflow in m<sup>3</sup>/h, m<sup>3</sup>/s and cfm.

Pe = Static pressure in mm.w.c., Pa and inwg.

**Impeller diameter (cm): 140    Number of poles: 8    Number of blades: 9**

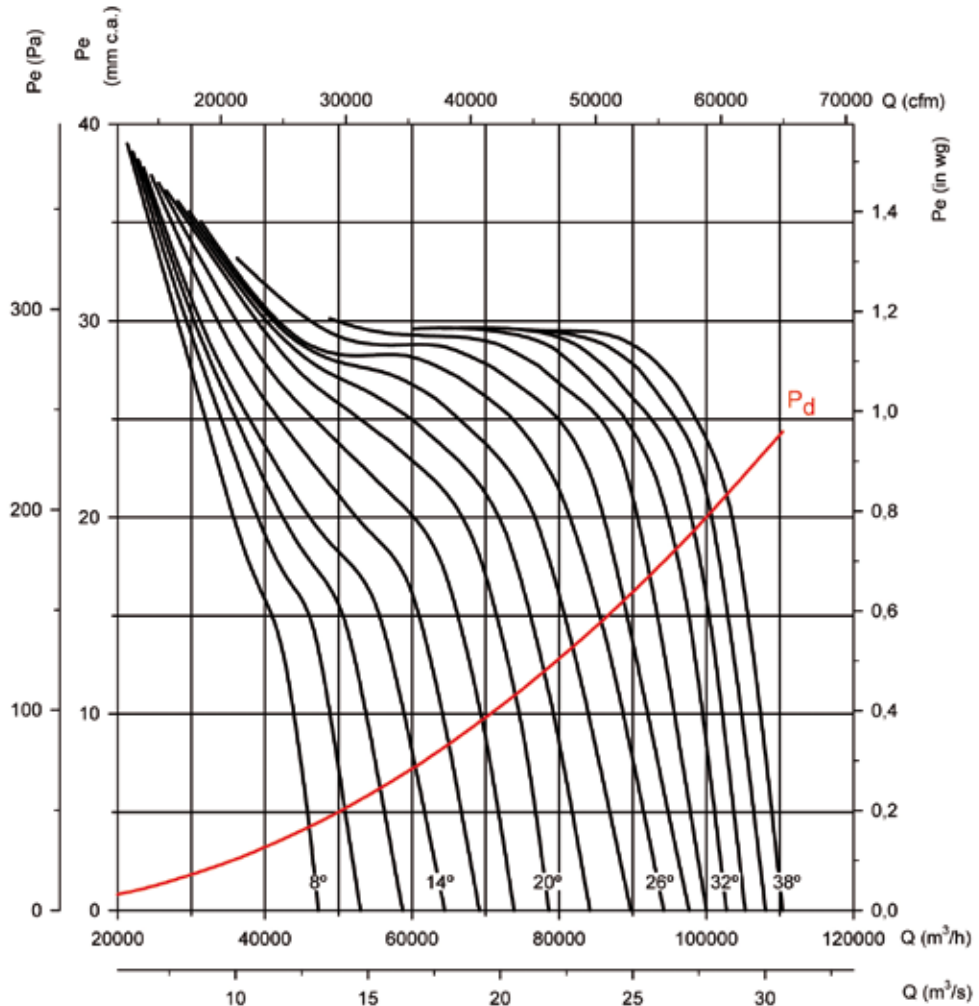

### Absorbed power

### Recommended motor power kW (CV)

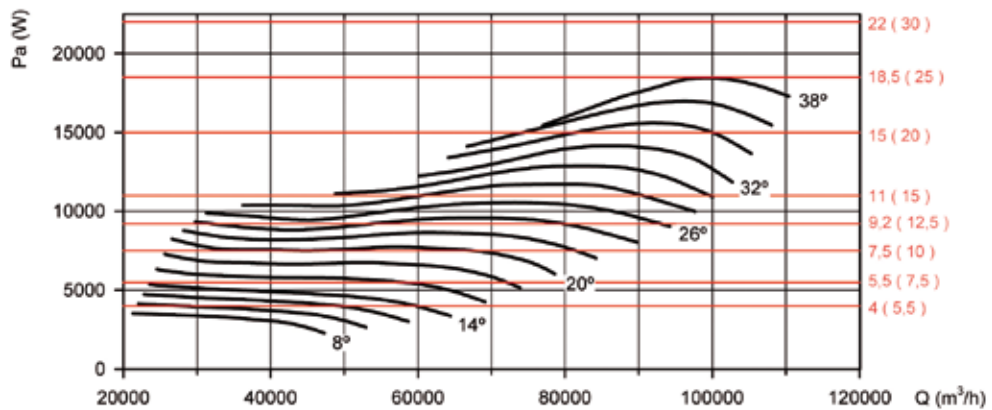

Characteristic curves

THT

CJTHT/PLUS

CJTHT

CJTHT/DUPLEX/ATEX

Q = Airflow in m<sup>3</sup>/h, m<sup>3</sup>/s and cfm.

Pe = Static pressure in mm.w.c., Pa and inwg.

Impeller diameter (cm): 160

Number of poles: 6

Number of blades: 3

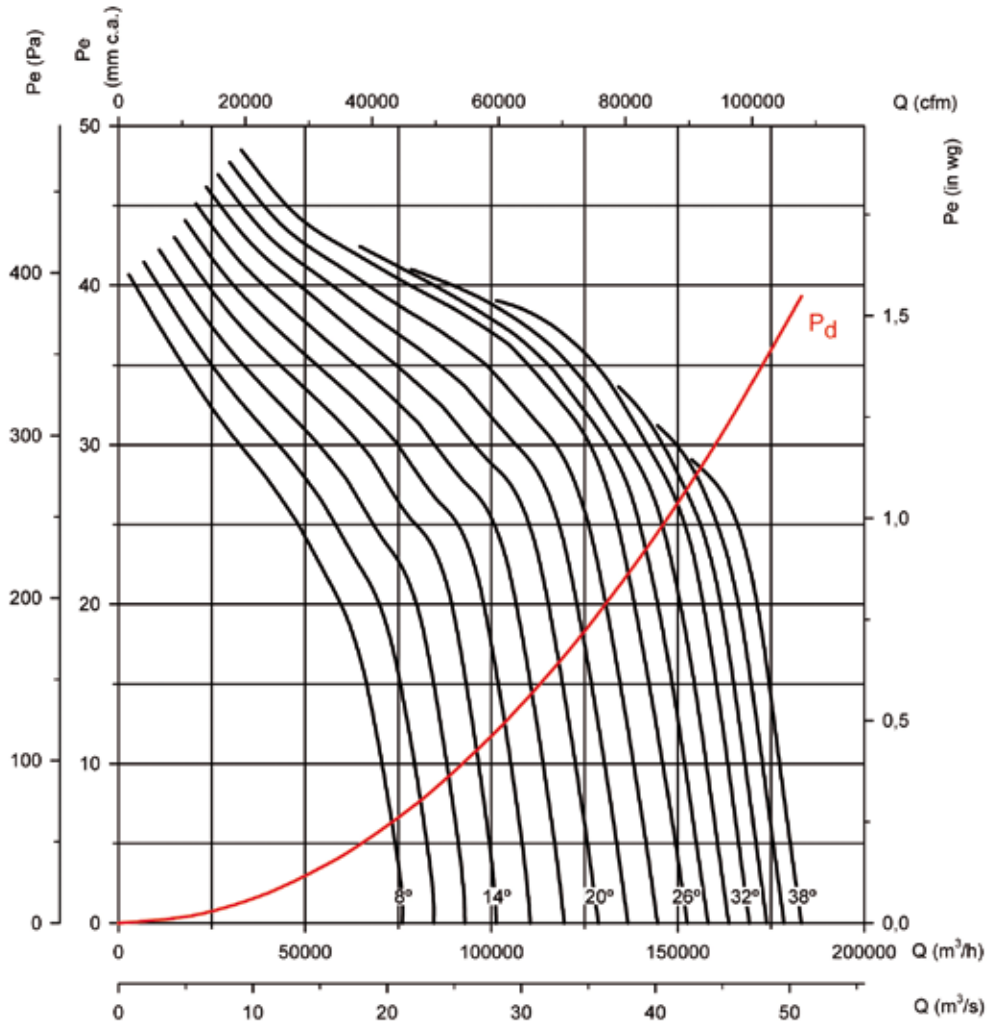

Absorbed power

Recommended motor power kW (CV)

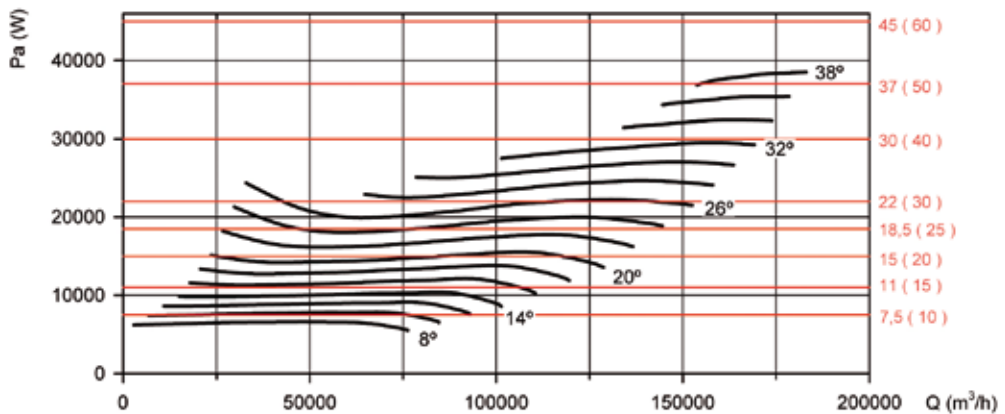

# THT CJTHT/PLUS CJTHT CJTHT/DUPLEX/ATEX

## Characteristic curves

THT CJTHT/PLUS CJTHT CJTHT/DUPLEX/ATEX

Q = Airflow in m<sup>3</sup>/h, m<sup>3</sup>/s and cfm.

Pe = Static pressure in mm.w.c., Pa and inwg.

**Impeller diameter (cm): 160    Number of poles: 6    Number of blades: 6**

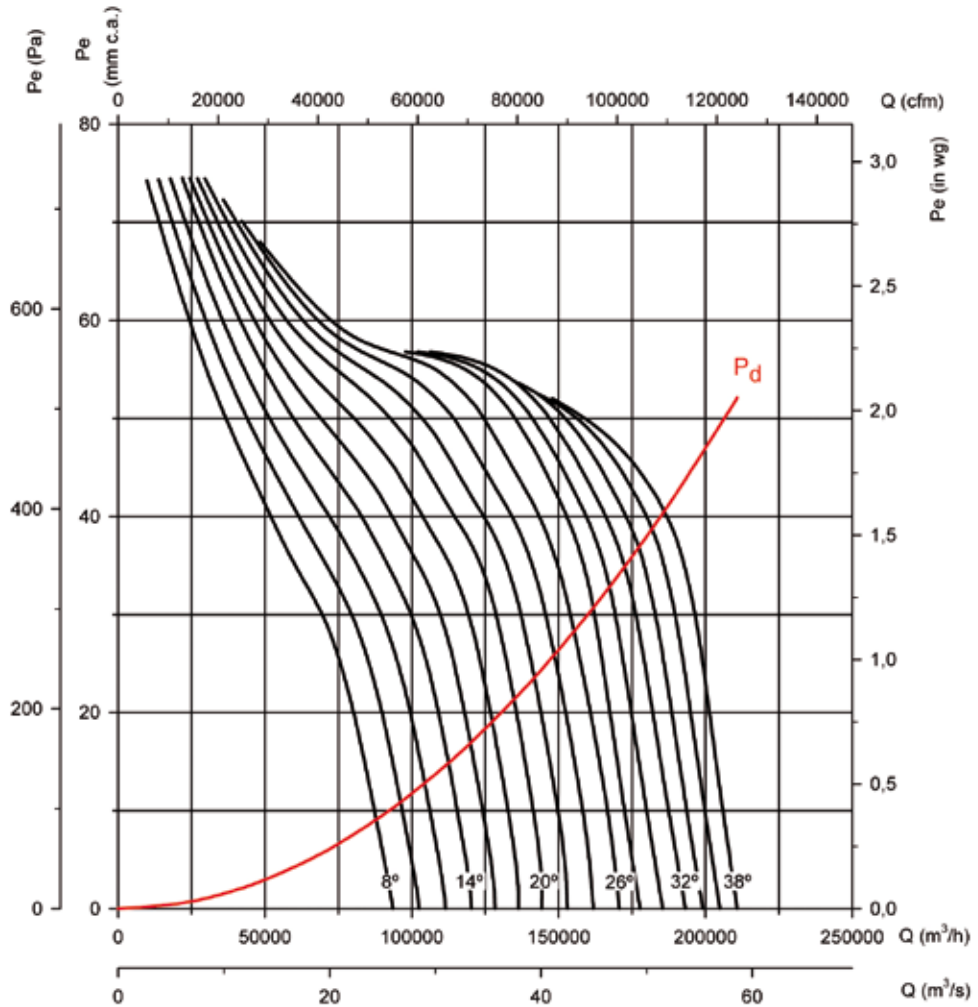

### Absorbed power

### Recommended motor power kW (CV)

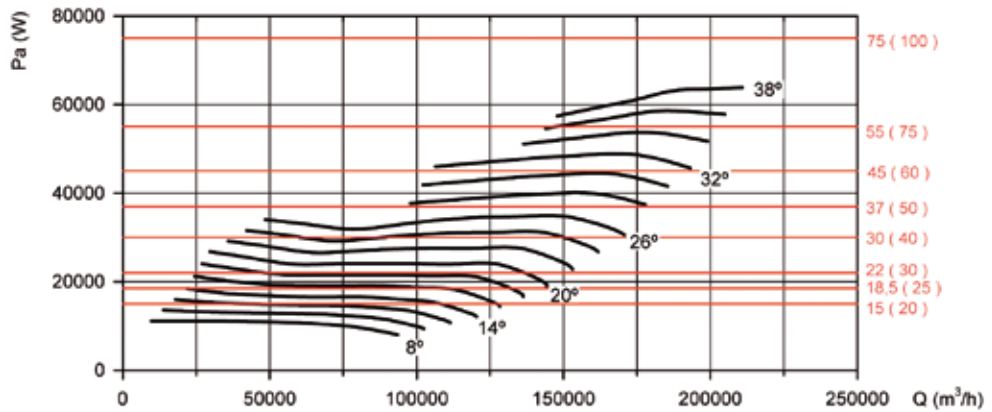

**Characteristic curves**

THT

CJTHT/PLUS

CJTHT

CJTHT/DUPLEX/ATEX

Q = Airflow in m<sup>3</sup>/h, m<sup>3</sup>/s and cfm.

Pe = Static pressure in mm.w.c., Pa and inwg.

**Impeller diameter (cm): 160**

**Number of poles: 6**

**Number of blades: 9**

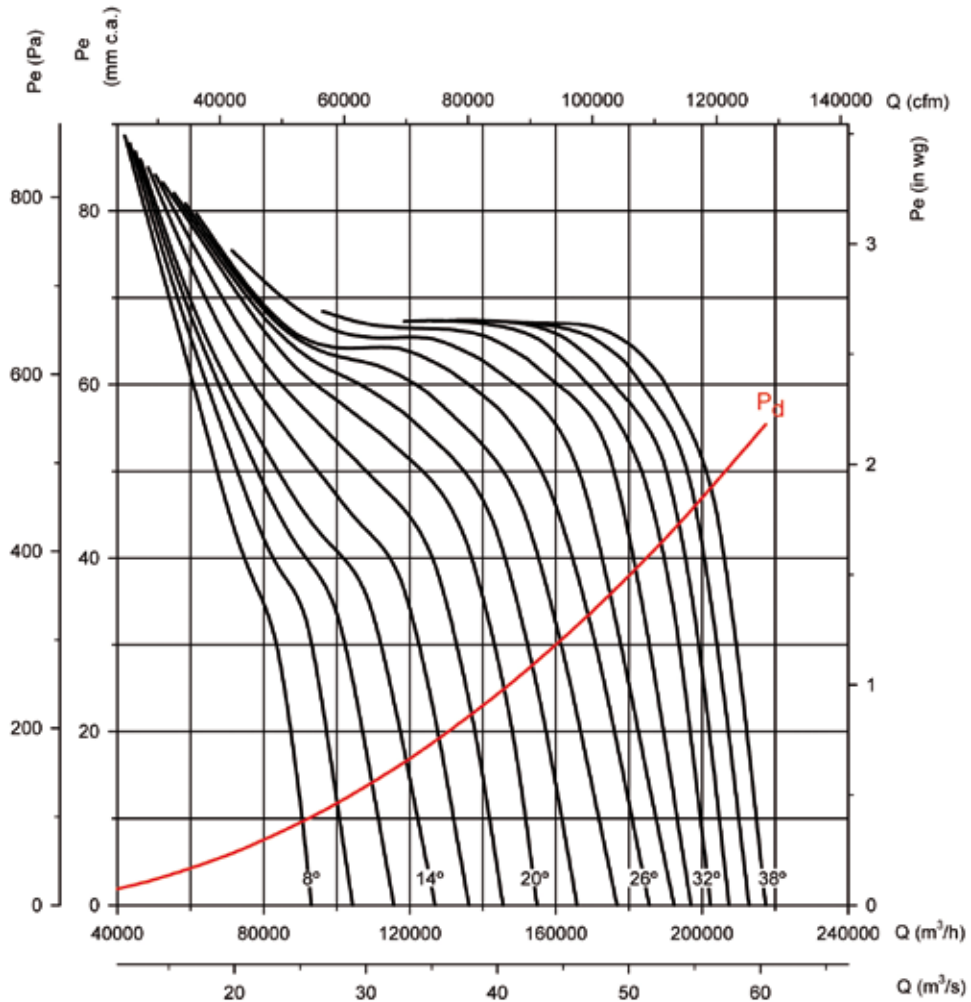

**Absorbed power**

**Recommended motor power kW (CV)**

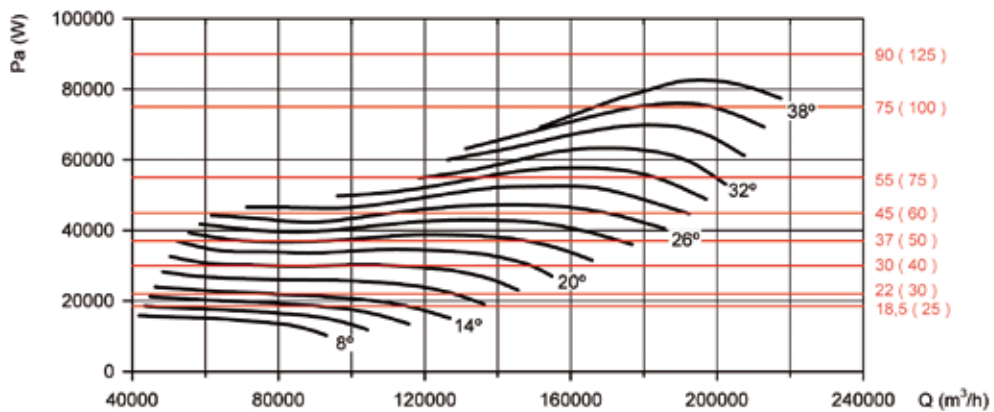

# THT CJTHT/PLUS CJTHT CJTHT/DUPLEX/ATEX

## Characteristic curves

THT

CJTHT/PLUS

CJTHT

CJTHT/DUPLEX/ATEX

Q = Airflow in m<sup>3</sup>/h, m<sup>3</sup>/s and cfm.

Pe = Static pressure in mm.w.c., Pa and inwg.

Impeller diameter (cm): 160

Number of poles: 8

Number of blades: 3

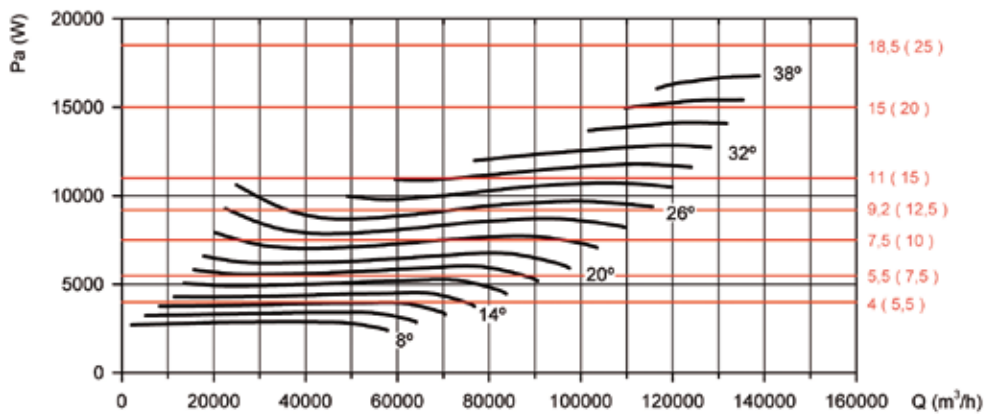
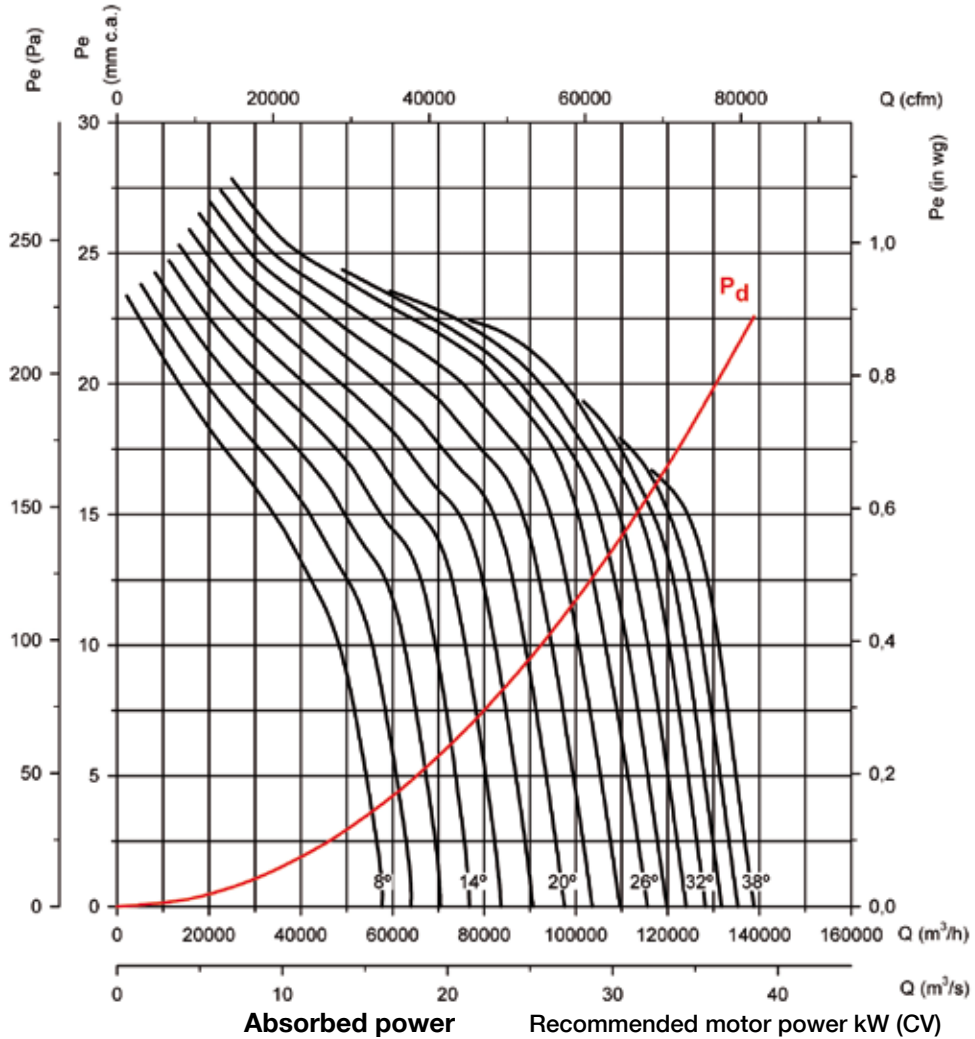

Characteristic curves

THT CJTHT/PLUS CJTHT CJTHT/DUPLEX/ATEX

Q = Airflow in m<sup>3</sup>/h, m<sup>3</sup>/s and cfm.

Pe = Static pressure in mm.w.c., Pa and inwg.

Impeller diameter (cm): 160 Number of poles: 8 Number of blades: 6

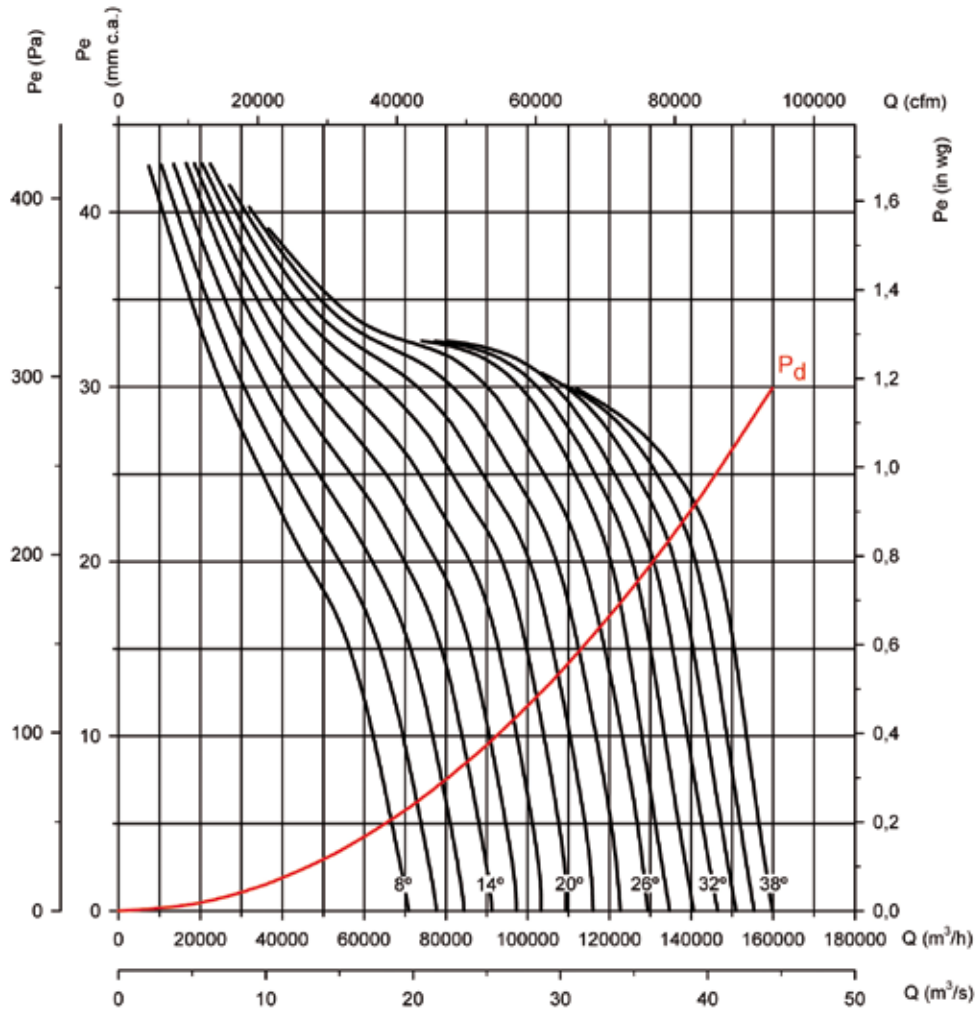

Absorbed power

Recommended motor power kW (CV)

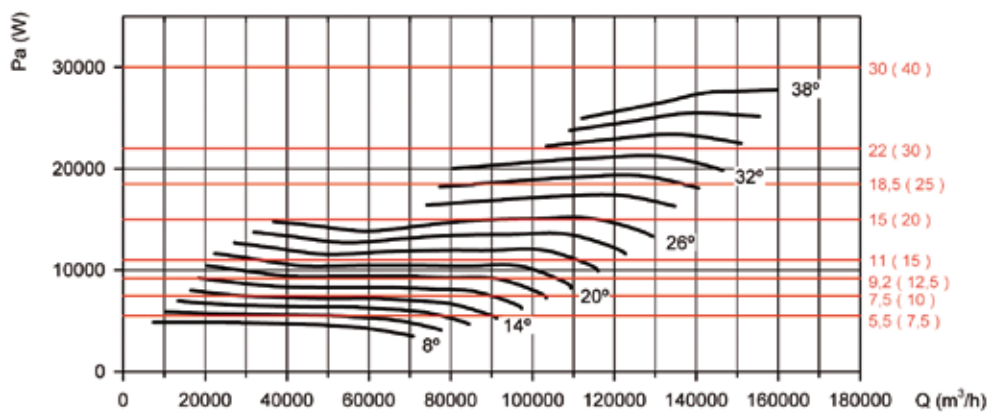

# THT CJTHT/PLUS CJTHT CJTHT/DUPLEX/ATEX

## Characteristic curves

THT CJTHT/PLUS CJTHT CJTHT/DUPLEX/ATEX

Q = Airflow in m<sup>3</sup>/h, m<sup>3</sup>/s and cfm.

Pe = Static pressure in mm.w.c., Pa and inwg.

**Impeller diameter (cm): 160    Number of poles: 8    Number of blades: 9**

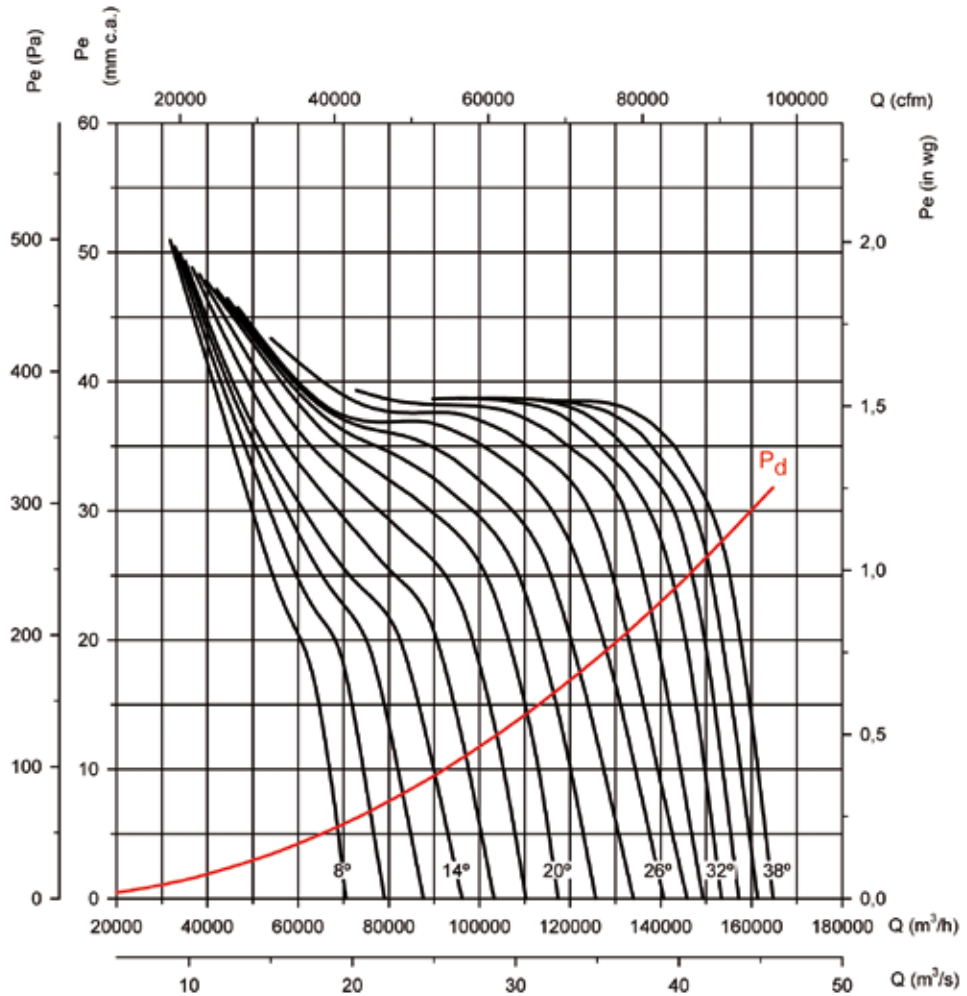

Absorbed power

Recommended motor power kW (CV)

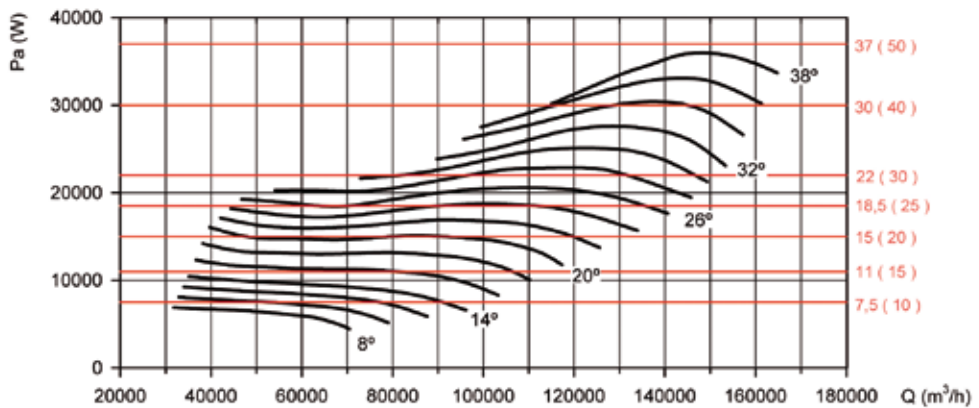

# THT/IMP

**400°C/2h, 300°C/1h and 200°C/2h single-direction or reversible long-range impulsion fans**

200°C/2h, 300°C/1h and 400°C/2h single-direction or reversible long-range impulsion fans with circular, (THT/IMP-C), octagonal (THT/IMP-L) or painted octagonal (THT/IMP-O) design



THT/IMP-C



THT/IMP-O



THT/IMP-L

**Fan:**

- Single-direction or reversible ventilation unit consisting of a fan, silencers, deflectors and brackets, certified for smoke extraction in accordance with standard EN-12101-3-2002, certification no. 0370-CPD-0394
- Turnable impellers cast aluminium designed for optimum thrust.
- Protection guard against contacts, in accordance with standard UNE 100250, in single-direction models
- Deflector to increase airflow range, on the impeller side. Reversible models are fitted with deflectors on both sides.
- Highly effective silencers with thermal and acoustic insulation
- Safety switch, IAT series, supplied built-in to the fan (THT/IMP-L and THT/IMP-O) or on request (THT/IMP-C)
- Airflow direction from motor to impeller or 100% reversible
- THT/IMP-C: Steel sheet circular casing
- THT/IMP-L: galvanized sheet steel casing
- THT/IMP-O: painted steel casing, with minimum height
- THT/IMP-LS: Casing limited



Deflector to increase range

**Motor:**

- Class H motors, ongoing use S1 and emergency use S2, with ball bearings and IP55 protection, 2-speed
- Three-phase 400V.-50Hz. DHALANDER
- Max. temperature of air for transport: S1 Service -20°C+ 40°C for ongoing use, S2 Service 200°C/2h, 300°C/2h, 400°C/2h

**Finish:**

- Anticorrosive in polyester resin, polymerised at 190°C, after alkaline degreasing and phosphate-free pre-treatment (THT/IMP-C, THT/IMP-O) or anticorrosive galvanized sheet steel (THT/IMP-L)

**On request:**

- Different thrust performance from that indicated.

**Order code**

**THT/IMP O — UNI — 38 — 2/4T — 1,5 — F-400**

THT/IMP:  
Long-distance  
impulse fans

Design  
C: Circular casing  
O: Painted casing  
L: casing  
LS: Casing  
limited

Airflow direction  
UNI: Unidirectional  
REV: Reversible

Impeller  
diameter  
in cm.

Number of  
motor poles  
2=2900 r/min. 50 Hz  
4=1400 r/min. 50 Hz  
6=900 r/min. 50 Hz  
8=750 r/min. 50 Hz  
12=500 r/min. 50 Hz

T=Three-phase  
Motor power  
(c.v.)

F-200 Officially approved  
200°C/2h  
F-300 Officially approved  
300°C/1h  
F-400 Officially approved  
400°C/2h

## Technical characteristics

Model	Speed (r/min)	Maximum current 400V (A)	Airflow (m³/h)	Thrust (N)	Speed inlet (m/s)	Power installed (kW)	LpA sound pressure at 10m dB(A)	Approx. weight (Kg)
<b>Single-direction</b>								
THT/IMP-C-UNI-31-2/4T	2860/ 1430	1.50/ 0.55	4260 / 2130	21/ 5	15.6/ 7.8	0.55 / 0.15	51/ 36	65
THT/IMP-C-UNI-35-2/4T	2875/ 1430	2.10/ 0.80	6360 / 3180	36/ 9	17.8 / 8.9	0.85 / 0.20	52/ 37	70
THT/IMP-C-UNI-38-2/4T-1,5	2900/ 1450	2.90/ 1.10	8450 / 4225	57/ 15	20.7 / 10.3	1.10 / 0.25	47/ 32	89
THT/IMP-C-UNI-40-2/4T-1,5	2900/ 1450	2.90/ 1.10	9250 / 4625	60/ 15	20.4 / 10.2	1.10 / 0.25	53/ 38	98
THT/IMP-C-UNI-45-2/4T-2	2940/ 1460	4.40/ 1.40	10800 / 5400	62/ 15	18.1 / 9.0	1.50 / 0.37	57/ 42	132
THT/IMP-C-UNI-45-2/4T-3	2930/ 1450	5.70/ 1.80	13200 / 6600	92/ 23	22.1 / 11.0	2.20 / 0.60	58/ 43	133
THT/IMP-C-UNI-50-2/4T-6	2930/ 1450	10.00/ 3.20	19700 / 9850	165/ 41	26.4 / 13.2	4.50 / 1.30	60/ 45	220
THT/IMP-O-UNI-29-2/4T	2860/ 1430	1.50/ 0.55	4000 / 2000	21/ 5	16.8 / 8.4	0.55 / 0.15	37/ 22	69
THT/IMP-O-UNI-35-2/4T	2875/ 1430	2.10/ 0.80	6360 / 3180	36/ 9	17.8 / 8.9	0.85 / 0.20	52/ 37	70
THT/IMP-L-UNI-29-2/4T	2860/ 1430	1.50/ 0.55	4000 / 2000	21/ 5	16.8 / 8.4	0.55 / 0.15	37/ 22	69
THT/IMP-LS-UNI-29-2/4T	2860/ 1430	1.50/ 0.55	4000 / 2000	21/ 5	16.8 / 8.4	0.55 / 0.15	39/ 24	55
THT/IMP-L-UNI-35-2/4T	2875/ 1430	2.10/ 0.80	6360 / 3180	36/ 9	17.8 / 8.9	0.85 / 0.20	52/ 37	70
THT/IMP-LS-UNI-35-2/4T	2875/ 1430	2.10/ 0.80	6360 / 3180	36/ 9	17.8 / 8.9	0.85 / 0.20	54/ 39	56

## Reversible

THT/IMP-C-REV-31-2/4T	2860/ 1430	1.50/ 0.55	3840 / 1920	17/ 4	14.1 / 7.0	0.55 / 0.15	50/ 35	63
THT/IMP-C-REV-35-2/4T	2875/ 1430	2.10/ 0.80	5940 / 2970	31/ 8	16.7 / 8.3	0.85 / 0.20	51/ 36	70
THT/IMP-C-REV-38-2/4T-2	2940/ 1460	4.40/ 1.40	8200 / 4100	54/ 14	20.1 / 10.0	1.50 / 0.37	49/ 34	91
THT/IMP-C-REV-40-2/4T-2	2940/ 1460	4.40/ 1.40	9250 / 4625	60/ 15	20.4 / 10.2	1.50 / 0.37	52/ 37	100
THT/IMP-C-REV-45-2/4T-2	2940/ 1460	4.40/ 1.40	10300 / 5150	56/ 14	17.2 / 8.6	1.50 / 0.37	56/ 41	131
THT/IMP-C-REV-45-2/4T-3	2930/ 1450	5.70/ 1.80	12800 / 6400	87/ 22	21.4 / 10.7	2.20 / 0.60	57/ 42	133
THT/IMP-C-REV-50-2/4T-6	2930/ 1450	10.00/ 3.20	19000 / 9500	153/ 38	25.4 / 12.7	4.50 / 1.30	60/ 45	267
THT/IMP-O-REV-29-2/4T	2860/ 1430	1.50/ 0.55	3400 / 1700	15/ 4	14.3 / 7.1	0.55 / 0.15	38/ 23	67
THT/IMP-O-REV-35-2/4T	2875/ 1430	2.10/ 0.80	5940 / 2970	31/ 8	16.7 / 8.3	0.85 / 0.20	51/ 36	70
THT/IMP-L-REV-29-2/4T	2860/ 1430	1.50/ 0.55	3400 / 1700	15/ 4	14.3 / 7.1	0.55 / 0.15	38/ 23	67
THT/IMP-LS-REV-29-2/4T	2860/ 1430	1.50/ 0.55	3400 / 1700	15/ 4	14.3 / 7.1	0.55 / 0.15	40/ 25	55
THT/IMP-L-REV-35-2/4T	2875/ 1430	2.10/ 0.80	5940 / 2970	31/ 8	16.7 / 8.3	0.85 / 0.20	51/ 36	70
THT/IMP-LS-REV-35-2/4T	2875/ 1430	2.10/ 0.80	5940 / 2970	31/ 8	16.7 / 8.3	0.85 / 0.20	53/ 38	56



Dimensions in mm

C: Circular casing

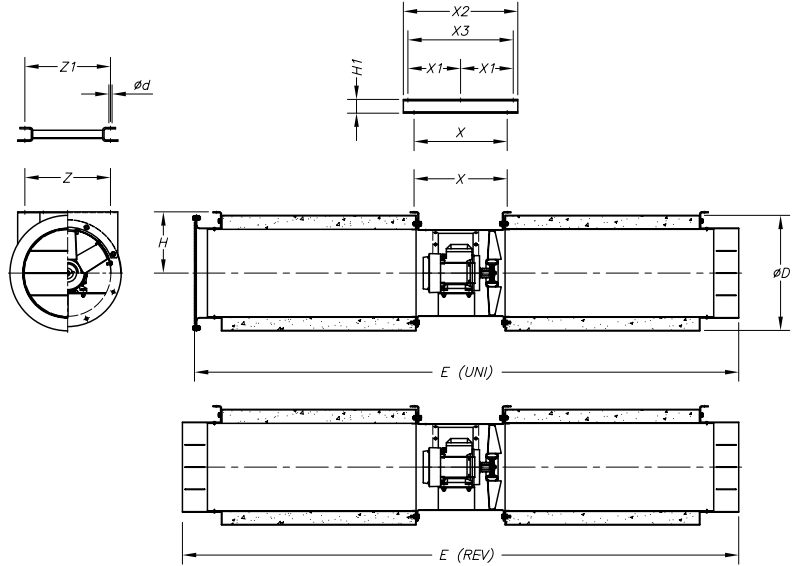

Model	ØD	Ød1	E (UNI)	E (REV)	H	H1	X	X1	X2	X3	Z	Z1
THT/IMP-C-31	415	10	1956	2000	220	-	345	-	-	-	275	-
THT/IMP-C-35	460	12	1960	2005	250	-	346	-	-	-	300	-
THT/IMP-C-38	415	12	2570	2620	225	-	-	-	600	530	-	517
THT/IMP-C-40	510	12	2485	2540	280	-	376	-	-	-	400	-
THT/IMP-C-45	630	12	2500	2554	355	-	396	-	-	-	440	-
THT/IMP-C-50	710	12	2895	2950	410	80	514	320	700	-	380	370

O: painted enclosure  
L: Surround  
LS: Surround small

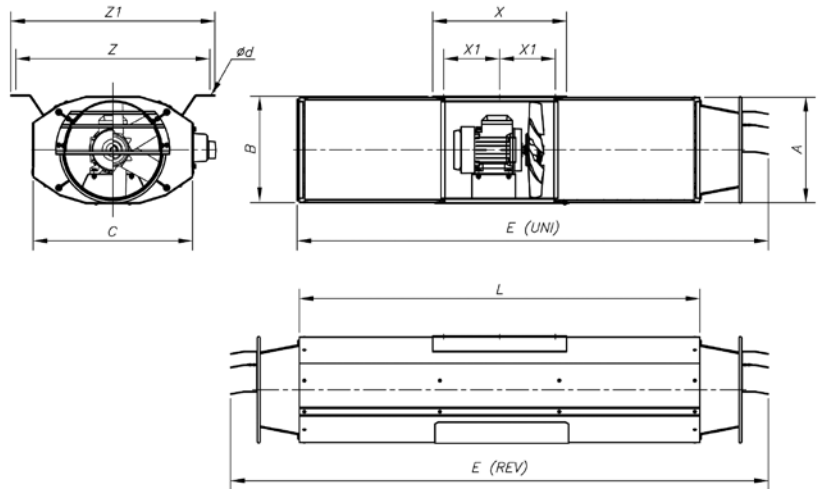

	A	B	C	Ød	E (UNI)	E (REV)	L	X	X1	Z	Z1
THT/IMP-LS-29	319,5	324	479	12x26	1410	1610	1200	400	167	580	610
THT/IMP-L-29	319,5	324	479	12x26	2210	2410	2000	400	167	580	610
THT/IMP-O-29	319,5	324	479	12x26	2210	2410	2000	400	167	580	610
THT/IMP-LS-35	383	386	523	12x26	1410	1610	1200	400	167	614	644
THT/IMP-L-35	383	386	523	12x26	2210	2410	2000	400	167	614	644
THT/IMP-O-35	383	386	523	12x26	2210	2410	2000	400	167	614	644

**Application in garages**



Installation of fan inside fire danger zone

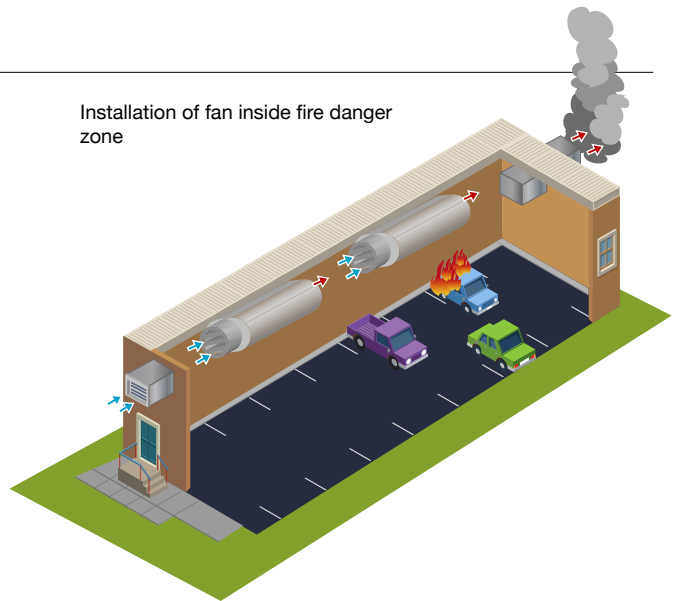

**Accessories**

See accessories section



# TUNNEL JET FAN



**Jet fans especially designed for tunnel ventilation. 400°C/2h, 300°C/1h and 200°C/2h Certificates according to model**

Powerful jet fans especially designed for tunnels ventilation for the smoke extraction in case of fire 400°C/2h, 300°C/1h and 200°C/2h according to model.

**THT/IMP:** Single-direction jet fan of great strength and cast-aluminium impeller construction for medium thrust. 400°C/2h, 300°C/1h and 200°C/2h Certificates

**VST:** 95% reversible jet fan in both direction of turn, of great strength and stainless steel impeller construction for high-performance thrust. Certified 400°C/2h



**Fan:**

- Sheet steel thick long casing
- Motor base welded to the casing
- Aerodynamic inlet and discharge cone.
- Optimum surface protection by means of high-quality steel.
- Model VST: 95% reversible impeller in the inverse direction, of high aerodynamic performance, built with hollow-profile stainless-steel blades.
- Model THT/IMP: Single-direction, cast aluminium impeller.
- THT/IMP-C: Base plate especially designed to support the entire unit. From diameter 560 mm upwards supplied with anti-vibration damper springs
- Tubular silencer connected to both ends which provides a high degree of thermal and acoustic insulation.
- Electrical connection in outside connecting box.
- E90-type cable with metallic protection.
- Stand based or bed based according to model, included in the set
- Shock absorbers
- Safety anchorage included
- Model VST: Approval according to Standard: EN-12101-3, with certification no. 1511-CPD-128.
- Model THT/IMP: Approval according to Standard: EN-12101-3, with certification no. 0370-CPD-0305.

**Motor:**

- Class H motors, ongoing use S1 and emergency use S2, with ball bearings and IP55 protection
- Three-phase 400/690V.-50Hz
- Max. temperature of air for transport:
- S1 Service -20°C + 70°C for ongoing use
- S2 Service 400°C/2h for VST
- S2 service 400°C/2h, 300°C/1h and 200°C/2h for THT/IMP

**Finish:**

- High-protection, anti-corrosion steel, specially primed and high-quality paint for corrosive environments.

**On request:**

- Standardised IP-55 motors, ATEX motors and two speeds
- Made entirely from stainless steel.
- Hot-rolled galvanised steel construction



High performance impeller



Guidelines for pressure gain



## Order code

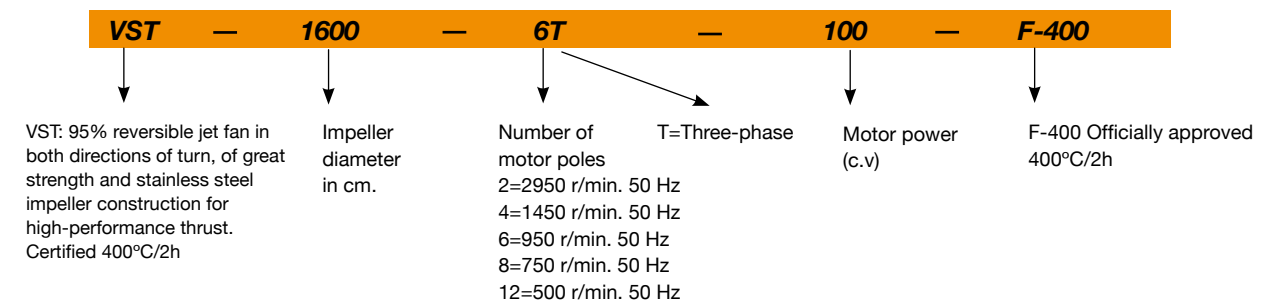
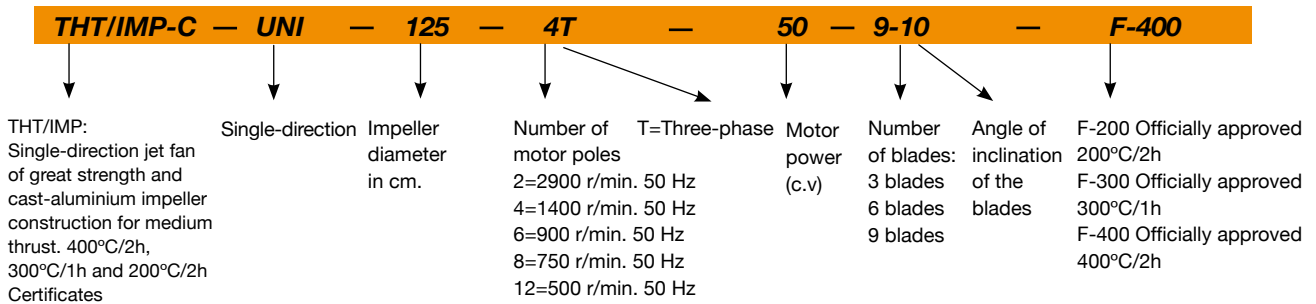

## Technical characteristics

Model	Speed (r/min)	Maximum admissible current 400V (A)	Airflow (m³/h)	Thrust (N)	Speed Impulsion (m/s)	Power installed (kW)	LpA sound pressure at 10m dB(A)	Approx. weight (Kg)
THT/IMP-C-UNI-56-2T-12	2950	19.20	29500	312	37.60	9	64	273
THT/IMP-C-UNI-56-4T-2	1450	3.60	14550	76	16.40	1.5	50	197
THT/IMP-C-UNI-63-2T-22	2960	32.30	40050	455	37.10	16	68	323
THT/IMP-C-UNI-63-4T-3	1450	5.20	21550	132	19.20	2.2	53	241
THT/IMP-C-UNI-71-4T-4	1450	6.60	28550	182	20.00	3	65	279
THT/IMP-C-UNI-80-4T-5,5	1450	8.40	36900	239	20.40	4	63	414
THT/IMP-C-UNI-90-4T-10	1450	17.70	52000	375	22.70	7.5	65	495
THT/IMP-C-UNI-100-4T-15	1450	22.00	66500	497	23.50	11	63	667
THT/IMP-C-UNI-125-4T-30	1450	42.00	98100	692	22.20	22	59	980
THT/IMP-C-UNI-125-4T-50	1450	73.00	123700	1101	28.00	37	62	1110

Model	Speed (r/min)	Airflow maximum (m³/h)	Thrust (N)	Speed Impulsion (m/s)	Discharge area (m²)	Max. Power installed (kW)	Approx. weight (Kg)
VST-560-2T	2950	27669	289	31	0.25	18.5	350
VST-630-2T	2950	39314	461	35	0.31	18.5	355
VST-710-2T	2950	48876	561	34	0.40	18.5	380
VST-800-2T	2950	72489	972	40	0.50	37	520
VST-800-4T	1450	38205	270	21	0.50	30	425
VST-900-2T	2950	86754	1100	38	0.64	37	770
VST-900-4T	1450	56466	466	25	0.64	30	650
VST-1000-2T	2950	115013	1566	41	0.79	55	835
VST-1000-4T	1450	81586	788	29	0.79	55	710
VST-1120-4T	1450	112949	1204	32	0.99	45	940
VST-1250-4T	1450	157857	1888	36	1.23	90	1030
VST-1400-4T	1450	201032	2441	36	1.54	90	1385
VST-1600-4T	1450	318874	4644	44	2.01	200	1890

\* Models 1800 and 2000 to consult

## Dimensions in mm

### THT/IMP-C

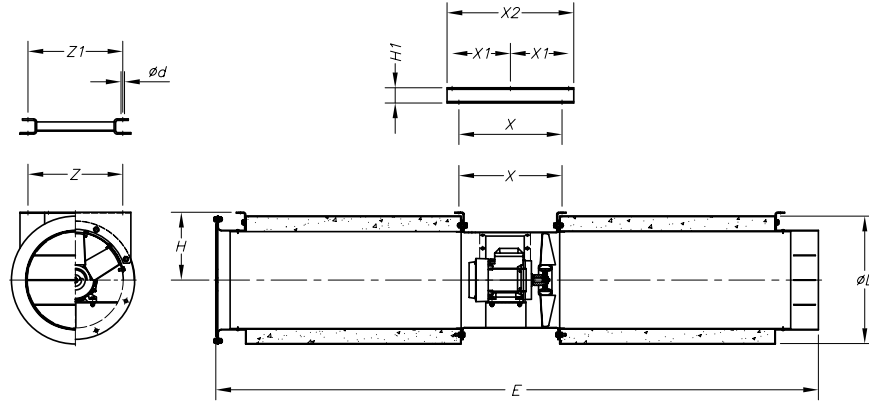

MODEL	øD	ød	E	H	H1	X	X1	X2	Z	Z1
THT/IMP-C-56	750	12	3145	415	80	558	345	750	475	465
THT/IMP-C-63	800	14	3295	435	80	706	418	900	550	540
THT/IMP-C-71	900	14	3145	510	80	558	345	750	475	465
THT/IMP-C-80	1000	14	3850	565	80	656	395	855	730	730
THT/IMP-C-90	1100	14	3850	585	80	677	405.5	876	825	825
THT/IMP-C-100	1200	14	4950	640	80	767	450	965	884	884
THT/IMP-C-125	1555	17	3620	840	100	717	575	1250	1150	1150

### VST

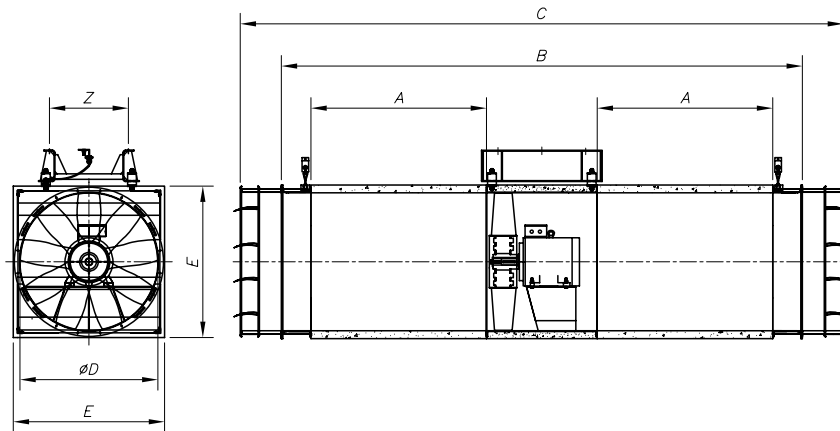

Model	A	B	C	øD	E	Z
VST-560	1950	4380	4780	562	762	380
VST-630	1950	4600	5000	632	832	462
VST-710	1950	4630	5030	713	913	546
VST-800*	1450/1950	3900/4900	4300/5300	804	1004	610
VST-900*	1450/1950	4000/5000	4400/5400	904	1104	660
VST-1000*	1450/1950	4025/5025	4425/5425	1005	1205	730
VST-1120	1700	4750	5150	1128	1328	760
VST-1250	1700	4750	5150	1258	1458	786
VST-1400	1950	5610	6010	1410	1610	768
VST-1600	1950	5900	6300	1610	1810	868

\* Length of the silencer for a four-pole / two-pole motor

## Characteristic curves

Q = Airflow in m<sup>3</sup>/h, m<sup>3</sup>/s and cfm.

Pe = Static pressure in mm.w.c., Pa and inwg.

— Pressure - - - Thrust (N)

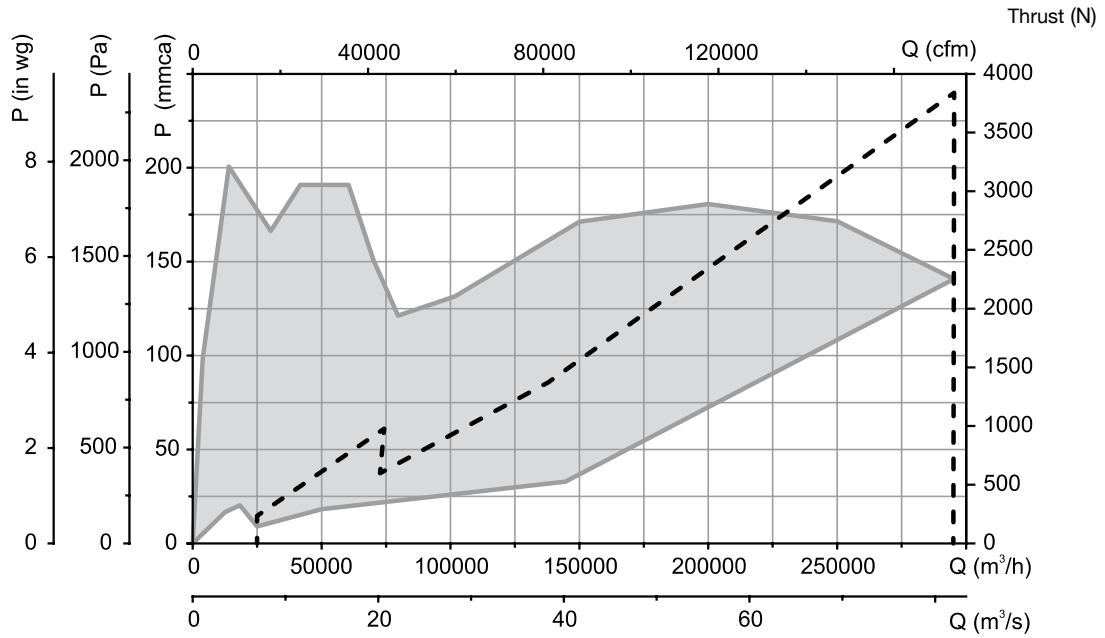

## Examples of use

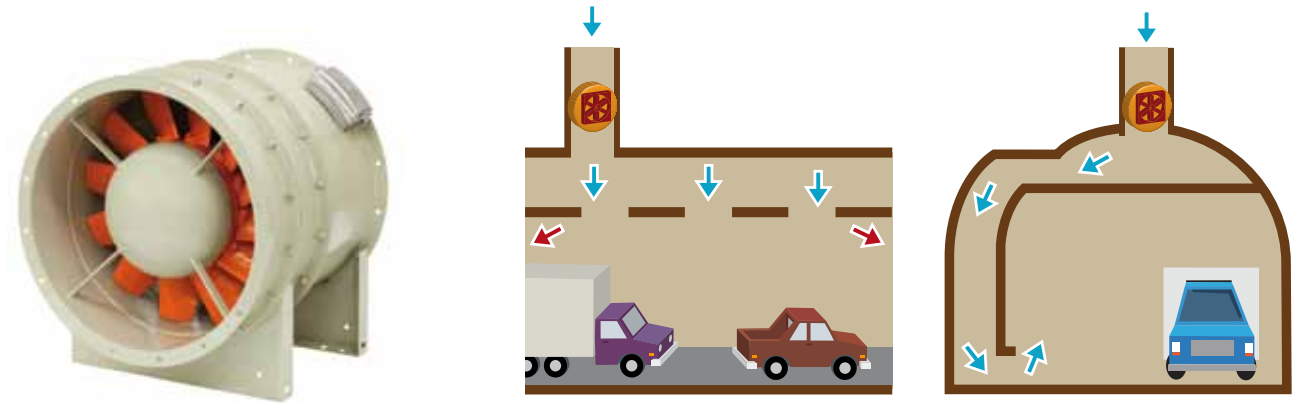

## Accessories

See accessories section



# VMSF

## Cased high-pressure axial fans, certified 400°C/2h



Cased axial high-pressure fans of great strength, especially designed for installations for smoke extraction with large losses of load, certified 400°C/2h.



### Fan:

- Sheet steel thick long casing
- Motor base welded to the casing
- Guidelines for high aerodynamic performance for pressure gain
- Optimum surface protection by means of high-quality steel.
- High-performance, cast aluminium impeller.
- Airflow direction from impeller to motor
- Electrical connection in outside terminal board.
- E90-type cable with metallic protection.
- Stand based or bed based according to model, included in the set
- Shock absorbers
- Approval according to Standard: EN-12101-3, with certification no. 1511-CPD-104.

### Motor:

- Class H motors, ongoing use S1 and emergency use S2, with ball bearings and IP55 protection
- Three-phase 400/690V.-50Hz
- Max. temperature of air for transport:
- S1 Service -20°C + 70°C for ongoing use
- S2 Service 400°C/2h

### Finish:

- High-protection, anti-corrosion steel, specially primed and high-quality paint for corrosive environments.

### On request:

- Standardised IP-55 motors, ATEX motors and two speeds
- Stainless steel or iron impellers
- Made entirely from stainless steel.
- Hot-rolled galvanised steel construction



High pressure impeller

## Order code

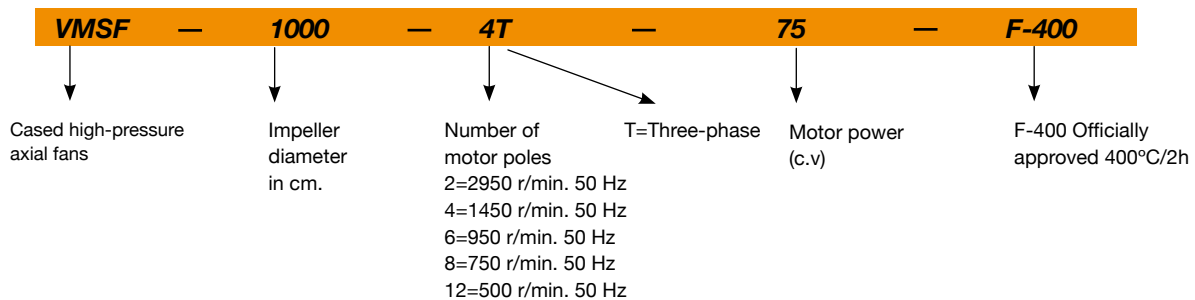

## Technical characteristics

Model	Speed	Max. Power installed and recommended (kW)	Airflow (m³/h)	Approx. weight (Kg)	
	(r/min)			min.	max.
VMSF-500-2T	2950	4	19000	93	102
VMSF-500-4T	1450	2.2	10259	93	102
VMSF-560-2T	2950	5.5	23530	103	133
VMSF-560-4T	1450	2.2	14356	103	133
VMSF-630-2T	2950	22	41410	120	252
VMSF-630-4T	1450	3	20397	120	252
VMSF-710-4T	1450	5.5	29363	137	238
VMSF-800-4T	1450	11	42079	173	238
VMSF-900-4T	1450	15	59999	214	290
VMSF-1000-4T	1450	30	82256	235	428
VMSF-1000-6T	950	7.5	53963	235	428
VMSF-1120-4T	1450	45	115506	504	910
VMSF-1120-6T	950	15	75850	504	910
VMSF-1250-4T	1450	75	159321	619	1180
VMSF-1250-6T	950	22	104031	619	1180

\* Models 1400 and 1600 to consult

## Dimensions in mm

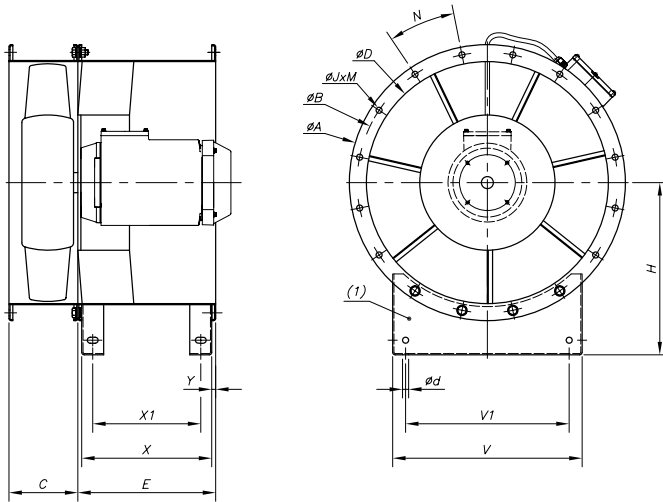

Model	ØA	ØB	C	ØD	Ød	E	H
VMSF-500	570	541	126	502	14	252	357
VMSF-560	641	605	160	562	14	320	400
VMSF-630	725	674	185	632	14	370	435
VMSF-710	805	755	185	713	14	370	500
VMSF-800	905	841	195	804	14	390	560
VMSF-900	1005	945	225	905	14	450	639
VMSF-1000	1105	1045	225	1005	14	450	690
VMSF-1120	1126	1175	270	1128	14	540	750
VMSF-1250	1370	1311	270	1258	14	540	790
VMSF-1400	1530	1469	330	1410	18	670	900
VMSF-1600	1742	1665	400	1610	18	800	1000

Model	ØJxM	N	V	V1	X	X1	Y
VMSF-500	Ø11.5x12	30°	438	360	235	185	8.5
VMSF-560	Ø14x16	22°30'	440	380	320	252	9
VMSF-630	Ø14x16	22°30'	530	462	352	302	9
VMSF-710	Ø14x16	22°30'	688	546	352	287	9
VMSF-800	Ø14x16	22°30'	760	610	370	305	10
VMSF-900	Ø14x16	22°30'	840	660	430	365	10
VMSF-1000	Ø14x16	22°30'	930	730	430	365	10
VMSF-1120	Ø14x20	18°	885	760	518	478	11
VMSF-1250	Ø14x20	18°	986	786	518	438	11
VMSF-1400	Ø14x24	15°	1007	767	644	564	13
VMSF-1600	Ø14x24	15°	1067	867	772	672	13

(1) Accessory

## Characteristic curves

Q = Airflow in m<sup>3</sup>/h, m<sup>3</sup>/s and cfm.

Pe = Static pressure in mm.w.c., Pa and inwg.

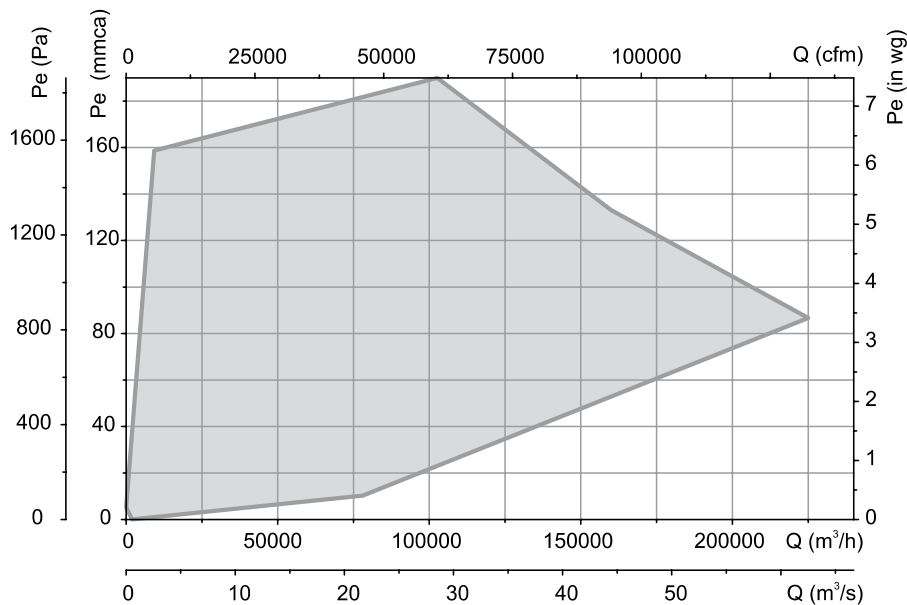

## Accessories

See accessories section



# CI

## Centrifugal long-range induction and impulsion fans 300°C/1h, for working within the fire danger zones, with low profile



Centrifugal long-range induction and impulsion fans 300°C/1h, for working within the fire danger zones, with low profile

### Fan:

- Steel sheet casing
- Impeller with backward-curved blades made from robust sheet steel
- Outside connecting box.
- Fixing stand included



Outside connecting box. Fixing stand

### Motor:

- Class H motors, ongoing use S1 and emergency use S2, with ball bearings, IP55 protection, and one- or two- speed depending on the model
- Three-phase 230/400V.50Hz. (up to 4CV.) and 400/690V.-50Hz. (power over 4CV.)

- Max. temperature of air for transport: S1 Service -20°C+ 40°C for ongoing use, S2 Service 300°C/2h

### Finish:

- Anticorrosive finish in polyester resin, polymerised at 190°C, after alkaline degreasing and phosphate-free pre-treatment.

## Order code

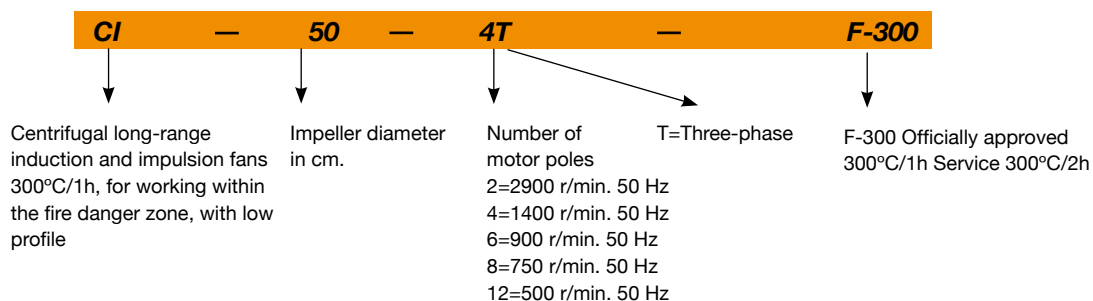

## Technical characteristics

Model	Speed (r/min)	Maximum admissible current (A)			Airflow (m³/h)	Thrust (N)	Impulsion speed (m/s)	Power installed (kW)	LpA sound pressure at 1m dB(A)	Approx. weight (Kg)
		230V	400V	690V						
CI-50-4T/A	1405	4,79	2,77		6860	50	21,9	1,20	78	80
CI-50-4/8T/A	1430 / 705		3,07 / 1,36		6860 / 3430	50 / 13	21,9 / 10,9	1,20 / 0,30	78 / 63	79
CI-75-4T	1420	7,98	4,61		9350	75	24,1	2,20	85	120
CI-75-4/8T	1430 / 700		4,84 / 2,00		9350 / 4675	75 / 19	24,1 / 12,1	2,20 / 0,55	85 / 70	120
CI-100-4T	1430		7,62	4,40	11950	100	25,0	4,00	89	221
CI-100-4/8T	1430 / 710		8,80 / 2,75		11950 / 5975	100 / 25	25,0 / 12,5	4,00 / 1,00	89 / 74	217

**Dimensions in mm**

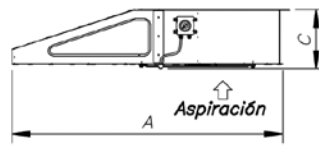
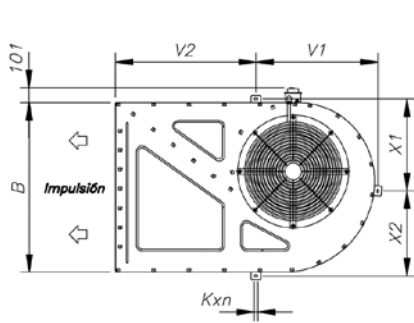

Model	A	B	C	V2	V1	X1	X2	Kxn
CI-50/A	1275,5	956	282,5	575	727	504	504	12x26
CI-75	1377	1065,5	351	620,5	783	557,5	559,5	12x26
CI-100	1800	1161	389	975	846	627,5	581	12x26

**Accessories**

See accessories section



# HTMF

## Multifunctional 400°C/2h and 300°C/1h roof fans

Multifunctional 400°C/2h ceiling fans to work inside fire danger zones, designed to smoke extraction in industrial or similar buildings.

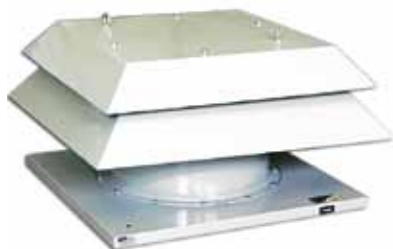

### Fan:

- Sheet steel base plate.
- Turnable impellers cast aluminium.
- Protection guard, meets UNE 100250 standard
- Sheet steel hood with natural outlet air. Approval according to Standard EN-12101-3-2002, certificate no.:0370-CPD-0544

### Motor:

- Class H motors, ongoing use S1 and emergency use S2, with ball bearings, IP55 protection, and one- or two- speed depending on the model.
- Three-phase 230/400V.-50Hz. (up to 4CV) and 400/690V.-50Hz. (power over 4CV)
- Max. temperature of air for transport: S1 Service -20°C+ 40°C for ongoing use, S2 Service 300°C/2h, 400°C/2h

### Finish:

- Anticorrosive finish in polyester resin, polymerised at 190°C, after alkaline degreasing and phosphate-free pre-treatment.

### On request:

- Fans with 200°C/2h one- or two-speed motor



Hood with natural outlet air due to differential pressure

## Order code

**HTMF — 56 — 4T — 2 — F-400**

HTMF: Multifunctional 400°C/2h and 300°C/1h roof fans

Impeller diameter in cm.

Number of motor poles  
 2=2900 r/min. 50 Hz  
 4=1400 r/min. 50 Hz  
 6=900 r/min. 50 Hz  
 8=750 r/min. 50 Hz  
 12=500 r/min. 50 Hz

T=Three-phase

Power motor (c.v.)

F-300 Officially approved 300°C/1h  
 F-400 Officially approved 400°C/2h

## Technical characteristics

Model	Speed (r/min)	Maximum admissible current (A)			Power installed (kW)	Airflow maximum (m³/h)	Sound pressure (1) level dB(A)		Approx. weight (Kg)
		230V	400V	690V			Inlet	Outlet	
HTMF-56-4T-1	1430	3.50	2.00		0.75	10545	62	59	79.0
HTMF-56-4T-1,5	1430	4.80	2.80		1.10	11400	63	60	79.0
HTMF-56-4/8T-1,5	1440 / 710		2.90 / 1.40		1.10 / 0.25	11400 / 5700	63 / 48	60 / 45	79.0
HTMF-56-6T-0,75	960	4.10	2.40		0.55	8170	51	49	80.0
HTMF-63-4T-1,5	1430	4.80	2.80		1.10	13870	65	62	94.0
HTMF-63-4/8T-1,5	1440 / 710		2.90 / 1.40		1.10 / 0.25	13870 / 6935	65 / 50	62 / 47	94.0
HTMF-63-4T-2	1420	6.20	3.60		1.50	15485	66	63	96.0
HTMF-63-4/8T-2	1415 / 715		3.60 / 1.50		1.50 / 0.30	15485 / 7742.5	66 / 51	63 / 48	106.0
HTMF-63-4T-3	1430	9.00	5.20		2.20	17955	67	64	108.0
HTMF-63-4/8T-3	1415 / 715		5.20 / 1.90		2.20 / 0.45	17955 / 8977.5	67 / 52	64 / 49	112.0
HTMF-63-6T-0,75	960	4.10	2.40		0.55	10260	56	54	95.0
HTMF-63-6T-1	950	4.70	2.70		0.75	11305	57	55	95.0
HTMF-71-4T-2	1420	6.20	3.60		1.50	16150	69	66	109.0
HTMF-71-4/8T-2	1415 / 715		3.60 / 1.50		1.50 / 0.30	16150 / 8075	69 / 54	66 / 51	119.0
HTMF-71-4T-3	1430	9.00	5.20		2.20	18430	71	68	122.0
HTMF-71-4/8T-3	1415 / 715		5.20 / 1.90		2.20 / 0.45	18430 / 9215	71 / 56	68 / 53	125.0
HTMF-71-4T-4	1430	11.80	6.80		3.00	22610	72	69	133.0
HTMF-71-4/8T-4	1425 / 710		6.80 / 2.20		3.00 / 0.60	22610 / 11305	72 / 57	69 / 54	135.0
HTMF-71-6T-1	950	4.70	2.70		0.75	13205	58	56	109.0

## Technical characteristics

Model	Speed (r/min)	Maximum admissible current (A)			Power installed (kW)	Airflow maximum (m³/h)	Sound pressure (1) level dB(A)		Approx. weight (Kg)
		230V	400V	690V			Inlet	Outlet	
HTMF-71-6T-1,5	955	5.90	3.40		1.10	16245	59	57	116.0
HTMF-80-4T-4	1430	11.80	6.80		3.00	27600	73	70	163.0
HTMF-80-4/8T-4	1425 / 710		6.80 / 2.20		3.00 / 0.60	27600 / 13800	73 / 58	70 / 55	165.0
HTMF-80-4T-5,5	1435		8.40	4.80	4.00	30176	74	71	163.0
HTMF-80-4/8T-5,5	1455 / 725		9.30 / 3.40		4.00 / 0.80	30176 / 15088	74 / 59	71 / 56	195.0
HTMF-80-6T-1,5	955	5.90	3.40		1.10	19412	62	60	145.0
HTMF-80-6T-2	950	6.70	3.90		1.50	22172	63	61	148.0
HTMF-80-6T-3	935	9.50	5.50		2.20	24932	64	62	160.0
HTMF-80-8T-1	710	4.80	2.80		0.75	16376	61	60	151.0
HTMF-90-4T-5,5	1435		8.40	4.80	4.00	35052	79	76	208.0
HTMF-90-4/8T-5,5	1455 / 725		9.30 / 3.40		4.00 / 0.80	35052 / 17526	79 / 64	76 / 61	238.0
HTMF-90-4T-7,5	1460		12.60	7.30	5.50	38456	81	78	240.0
HTMF-90-4/8T-7,5	1455 / 725		12.80 / 4.60		5.50 / 1.10	38456 / 19228	81 / 66	78 / 63	243.0
HTMF-90-4T-10	1460		17.70	10.20	7.50	41308	82	79	244.0
HTMF-90-4/8T-9	1455 / 725		15.60 / 6.30		6.70 / 1.50	41308 / 20654	82 / 67	79 / 64	243.0
HTMF-90-6T-3	935	9.50	5.50		2.20	29256	68	66	205.0
HTMF-90-6/12T-3	975 / 450		6.30 / 2.20		2.20 / 0.37	29256 / 14628	68 / 53	66 / 51	245.0
HTMF-90-6T-4	970	13.50	7.80		3.00	32016	69	67	235.0
HTMF-90-6/12T-4	975 / 450		8.40 / 2.50		3.00 / 0.40	32016 / 16008	69 / 54	67 / 52	245.0
HTMF-90-8T-1	710	4.80	2.80		0.75	17020	61	60	196.0
HTMF-90-8T-2	705	8.00	4.60		1.50	19596	63	62	208.0
HTMF-100-4T-7,5	1460		12.60	7.30	5.50	40756	84	81	265.0
HTMF-100-4/8T-7,5	1455 / 725		12.80 / 4.60		5.50 / 1.10	40756 / 20378	84 / 69	81 / 66	269.0
HTMF-100-4T-10	1460		17.70	10.20	7.50	47564	85	82	269.0
HTMF-100-4/8T-9	1455 / 725		15.60 / 6.30		6.70 / 1.50	44528 / 22264	84 / 69	81 / 66	269.0
HTMF-100-4T-15	1460		22.00	12.70	11.00	51336	86	83	332.0
HTMF-100-4/8T-14	1455 / 730		20.00 / 7.00		10.00 / 2.00	48300 / 24150	85 / 70	82 / 67	301.0
HTMF-100-6T-3	935	9.50	5.50		2.20	32476	74	72	231.0
HTMF-100-6/12T-3	975 / 450		6.30 / 2.20		2.20 / 0.37	32476 / 16238	74 / 59	72 / 57	271.0
HTMF-100-6T-4	970	13.50	7.80		3.00	35420	75	73	260.0
HTMF-100-6/12T-4	975 / 450		8.40 / 2.50		3.00 / 0.40	35420 / 17710	75 / 60	73 / 58	271.0
HTMF-100-6T-5,5	970		11.00	6.40	4.00	40020	76	74	277.0
HTMF-100-6/12T-5,5	975 / 450		10.50 / 5.00		4.00 / 0.80	40020 / 20010	76 / 61	74 / 59	289.0
HTMF-100-8T-3	705	10.40	6.00		2.20	26404	69	68	260.0
HTMF-100-8T-4	705	14.00	8.10		3.00	28704	70	69	270.0

(1) The sound level values are free field measurements of pressure in dB(A) at a distance of 6 m.

## Acoustic features

Values taken at inlet with maximum airflow.  Values taken at outlet with maximum airflow.

Sound power Lw(A) spectrum in dB(A) via frequency band in Hz.

Model	63	125	250	500	1000	2000	4000	8000	Model	63	125	250	500	1000	2000	4000	8000
56-4-1	46	67	74	79	82	78	71	60	71-4-2	50	71	78	83	86	82	75	64
56-4-1	43	64	71	76	79	75	68	57	71-4-3	55	76	83	88	91	87	80	69
56-4-1,5	47	68	75	80	83	79	72	61	71-4-3	52	73	80	85	88	84	77	66
56-4-1,5	44	65	72	77	80	76	69	58	71-4-4	56	77	84	89	92	88	81	70
56-6	35	56	63	68	71	67	60	49	71-4-4	53	74	81	86	89	85	78	67
56-6	33	54	61	66	69	65	58	47	71-6-1	42	63	70	75	78	74	67	56
56-8	32	53	60	65	68	64	57	46	71-6-1	40	61	68	73	76	72	65	54
56-8	29	50	57	62	65	61	54	43	71-6-1,5	43	64	71	76	79	75	68	57
63-4-1,5	49	70	77	82	85	81	74	63	71-6-1,5	41	62	69	74	77	73	66	55
63-4-1,5	46	67	74	79	82	78	71	60	71-8-2	38	59	66	71	74	70	63	52
63-4-2	50	71	78	83	86	82	75	64	71-8-2	35	56	63	68	71	67	60	49
63-4-2	47	68	75	80	83	79	72	61	71-8-3	40	61	68	73	76	72	65	54
63-4-3	51	72	79	84	87	83	76	65	71-8-3	37	58	65	70	73	69	62	51
63-4-3	48	69	76	81	84	80	73	62	71-8-4	41	62	69	74	77	73	66	55
63-6-0,75	40	61	68	73	76	72	65	54	71-8-4	38	59	66	71	74	70	63	52
63-6-0,75	38	59	66	71	74	70	63	52	80-4-4	57	78	85	90	93	89	82	71
63-6-1	41	62	69	74	77	73	66	55	80-4-4	54	75	82	87	90	86	79	68
63-6-1	39	60	67	72	75	71	64	53	80-4-5,5	58	79	86	91	94	90	83	72
63-8-1,5	34	55	62	67	70	66	59	48	80-4-5,5	55	76	83	88	91	87	80	69
63-8-1,5	31	52	59	64	67	63	56	45	80-6-1,5	46	67	74	79	82	78	71	60
63-8-2	35	56	63	68	71	67	60	49	80-6-1,5	44	65	72	77	80	76	69	58
63-8-2	32	53	60	65	68	64	57	46	80-6-2	47	68	75	80	83	79	72	61
63-8-3	36	57	64	69	72	68	61	50	80-6-2	45	66	73	78	81	77	70	59
63-8-3	33	54	61	66	69	65	58	47	80-6-3	48	69	76	81	84	80	73	62
71-4-2	53	74	81	86	89	85	78	67	80-6-3	46	67	74	79	82	78	71	60

## Acoustic features

☐ Values taken at inlet with maximum airflow. ☐ Values taken at outlet with maximum airflow.

Sound power Lw(A) spectrum in dB(A) via frequency band in Hz.

Model	63	125	250	500	1000	2000	4000	8000	Model	63	125	250	500	1000	2000	4000	8000
80-8-1	45	66	73	78	81	77	70	59	100-4-7,5	68	89	96	101	104	100	93	82
80-8-1	44	65	72	77	80	76	69	58	100-4-7,5	65	86	93	98	101	97	90	79
80-8-4	42	63	70	75	78	74	67	56	100-4-9	68	89	96	101	104	100	93	82
80-8-4	39	60	67	72	75	71	64	53	100-4-9	65	86	93	98	101	97	90	79
80-8-5,5	43	64	71	76	79	75	68	57	100-4-10	69	90	97	102	105	101	94	83
80-8-5,5	40	61	68	73	76	72	65	54	100-4-10	66	87	94	99	102	98	91	80
90-4-5,5	63	84	91	96	99	95	88	77	100-4-14	69	90	97	102	105	101	94	83
90-4-5,5	60	81	88	93	96	92	85	74	100-4-14	66	87	94	99	102	98	91	80
90-4-7,5	65	86	93	98	101	97	90	79	100-4-15	70	91	98	103	106	102	95	84
90-4-7,5	62	83	90	95	98	94	87	76	100-4-15	67	88	95	100	103	99	92	81
90-4-9	66	87	94	99	102	98	91	80	100-6-3	58	79	86	91	94	90	83	72
90-4-9	63	84	91	96	99	95	88	77	100-6-3	56	77	84	89	92	88	81	70
90-4-10	66	87	94	99	102	98	91	80	100-6-4	59	80	87	92	95	91	84	73
90-4-10	63	84	91	96	99	95	88	77	100-6-4	57	78	85	90	93	89	82	71
90-6-3	52	73	80	85	88	84	77	66	100-6-5,5	60	81	88	93	96	92	85	74
90-6-3	50	71	78	83	86	82	75	64	100-6-5,5	58	79	86	91	94	90	83	72
90-6-4	53	74	81	86	89	85	78	67	100-8-3	53	74	81	86	89	85	78	67
90-6-4	51	72	79	84	87	83	76	65	100-8-3	52	73	80	85	88	84	77	66
90-8-1	45	66	73	78	81	77	70	59	100-8-4	54	75	82	87	90	86	79	68
90-8-1	44	65	72	77	80	76	69	58	100-8-4	53	74	81	86	89	85	78	67
90-8-2	47	68	75	80	83	79	72	61	100-8-7,5	53	74	81	86	89	85	78	67
90-8-2	46	67	74	79	82	78	71	60	100-8-7,5	50	71	78	83	86	82	75	64
90-8-5,5	48	69	76	81	84	80	73	62	100-8-9	53	74	81	86	89	85	78	67
90-8-5,5	45	66	73	78	81	77	70	59	100-8-9	50	71	78	83	86	82	75	64
90-8-7,5	50	71	78	83	86	82	75	64	100-8-14	54	75	82	87	90	86	79	68
90-8-7,5	47	68	75	80	83	79	72	61	100-8-14	51	72	79	84	87	83	76	65
90-8-9	51	72	79	84	87	83	76	65	100-12-3	43	64	71	76	79	75	68	57
90-8-9	48	69	76	81	84	80	73	62	100-12-3	41	62	69	74	77	73	66	55
90-12-3	37	58	65	70	73	69	62	51	100-12-4	44	65	72	77	80	76	69	58
90-12-3	35	56	63	68	71	67	60	49	100-12-4	42	63	70	75	78	74	67	56
90-12-4	38	59	66	71	74	70	63	52	100-12-5,5	45	66	73	78	81	77	70	59
90-12-4	36	57	64	69	72	68	61	50	100-12-5,5	43	64	71	76	79	75	68	57

## Dimensions in mm

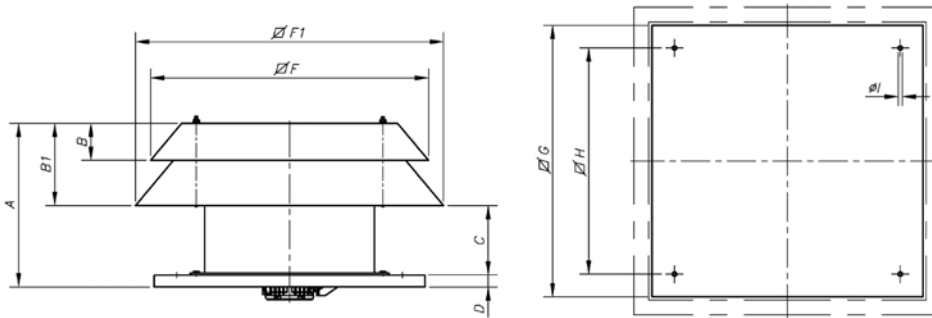

Model	A	B	B1	C	D	F	F1	G	H	ØI
HTMF-56	532	132	266	225	40	925	936	900	750	14
HTMF-63	577	141.5	311.5	225	40	1026	1058	1000	850	14
HTMF-71	661	156.5	351.5	270	40	1138	1180	1000	850	14
HTMF-80	721	176.5	401.5	270	50	1262	1313	1150	1000	14
HTMF-90	817	202	452	315	50	1425	1482	1150	1000	14
HTMF-100	957	212	492	415	50	1580	1642	1250	1100	14

## Characteristic curves

Q = Airflow in m<sup>3</sup>/h, m<sup>3</sup>/s and cfm.

Pe = Static pressure in mm.w.c., Pa and inwg.

### HTMF-56

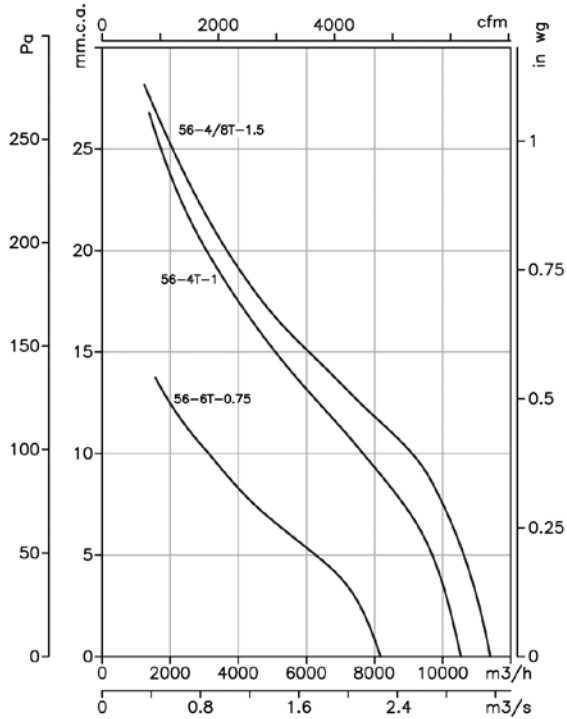

### HTMF-63

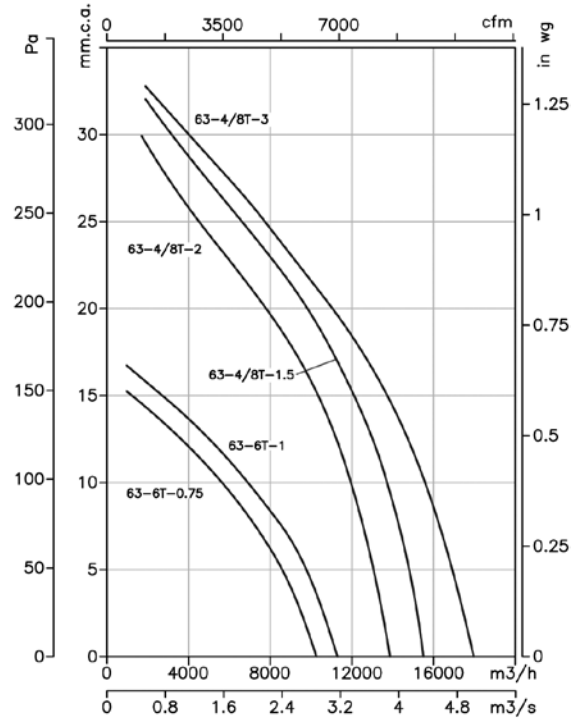

### HTMF-71

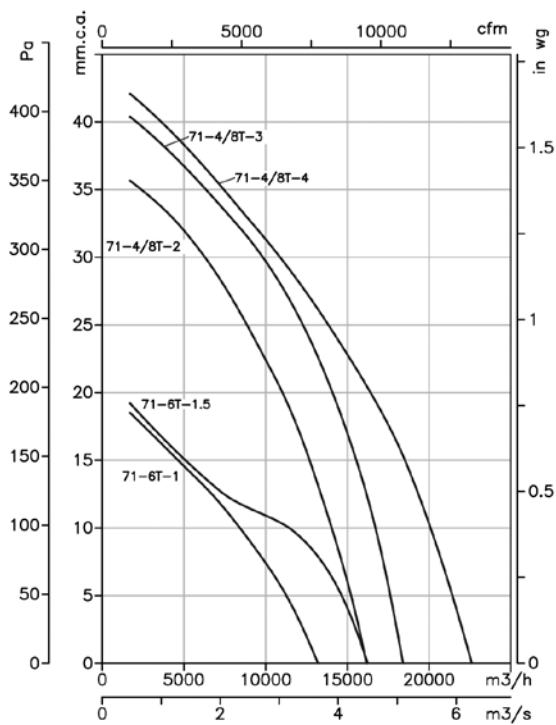

### HTMF-80

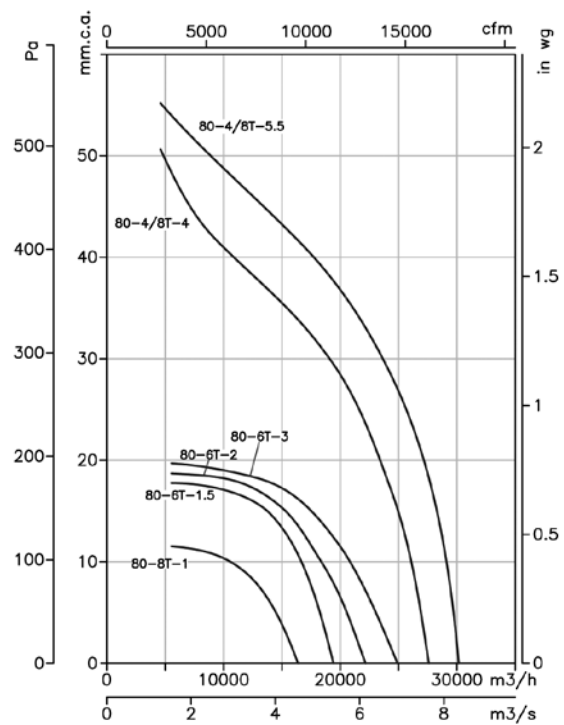

## Characteristic curves

Q = Airflow in m<sup>3</sup>/h, m<sup>3</sup>/s and cfm.

Pe= Static pressure in mm.w.c., Pa and inwg.

### HTMF-90

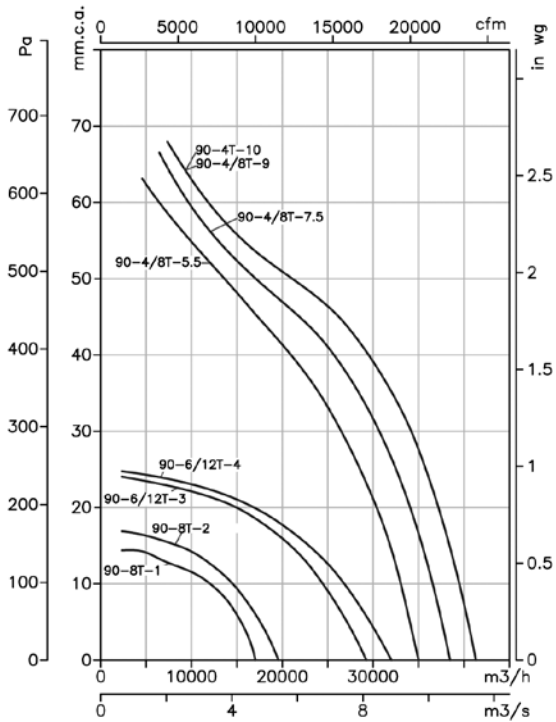

### HTMF-100

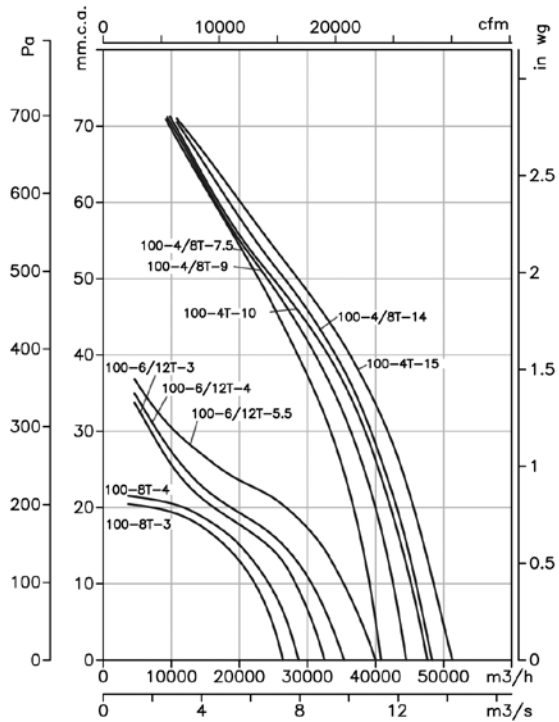

## Validation of the sound pressure according to distance

The sound level may vary depending on the structure of the roof.

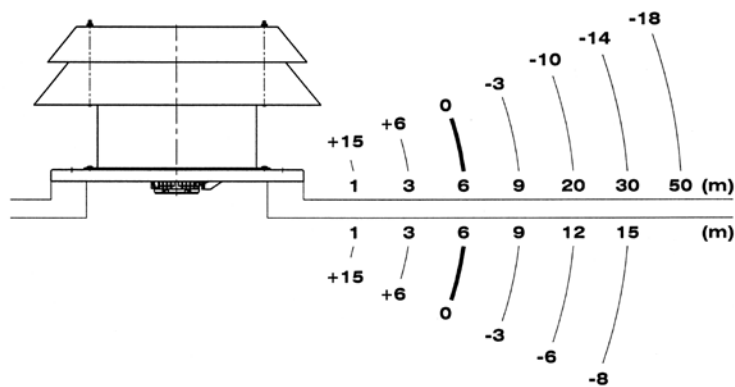

## Accessories

See accessories section



INT

IAT

CABLE BOX

C2V

AET

AR

CENTRAL CO

RFT

P-400

RT

# CJBDT/CBDT

**Double inlet and direct motor extraction units and centrifugal fans for working inside fire danger zones 400°C/2h and 300°C/1h, with possibility of single-phase motor**



Double inlet and direct motor extraction units and centrifugal fans for working inside fire danger zones 400°C/2h, with possibility of single-phase motor

**Fan:**

- Galvanized sheet steel casing
- Impeller with forward-facing blades made from galvanised sheet steel
- Outside connecting box.
- Anti-vibration dampers (CJBDT)
- Approval according to Standard EN12101-3:2002, certificate no.: 370-CPD-0580



**Motor:**

- Class H motors, ongoing use S1 and emergency use S2, with ball bearings, IP55 protection, and one- or two- speed depending on the model.
- Single-phase 230V 50 Hz. and Three-phase 230/400V.50Hz. (up to 4CV) and 400/690V.-50Hz. (power over 4CV)
- Max. temperature of air for transport: S1 Service -20°C + 60°C for ongoing use, S2 Service 300°C/2h, 400°C/2h

**Finish:**

- Anticorrosive galvanized sheet steel.

**On request:**

- Fans with circular inlet
- Fans with vertical outlet



Outside connecting box and base stands



Single-phase motors, 400°C/2h

**Order code**

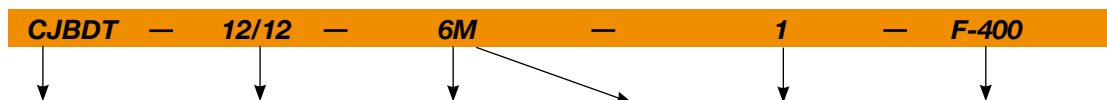

CJBDT: Double inlet and direct motor extraction units for working inside fire danger zones 400°C/2h and 300°C/1h, with possibility of single-phase motor

Turbine size

Number of motor poles  
 2=2900 r/min. 50 Hz  
 4=1400 r/min. 50 Hz  
 6=900 r/min. 50 Hz  
 8=750 r/min. 50 Hz  
 12=500 r/min. 50 Hz

M= Single-phase  
 T=Three-phase

Power motor (c.v.)

F-300 Officially approved 300°C/1h  
 F-400 Officially approved 400°C/2h

CBDT: Centrifugal double inlet and direct motor fans for working inside fire danger zones 400°C/2h and 300°C/1h, with possibility of single-phase motor

## Technical characteristics

Model		Speed (r/min)	Maximum admissible current (A)			Power installed (kW)	Airflow maximum (m³/h)	Sound pressure level dB(A)		Approx. weight (Kg)	
			230V	400V	690V			CJBDT	CBDT	CJBDT	CBDT
CJBDT-9/9-4T	CBDT-9/9-4T	1420	2.90	1.70		0.55	3000	64	66	44	24
CJBDT-9/9-4/8T	CBDT-9/9-4/8T	1440 / 710		1.76 / 0.76		0.55 / 0.15	3000 / 1750	64 / 51	66 / 53	45	25
CJBDT-9/9-4M	CBDT-9/9-4M	1410	4.10			0.55	3000	64	66	44	23
CJBDT-9/9-6T	CBDT-9/9-6T	920	1.50	0.90		0.25	2100	60	61	42	22
CJBDT-9/9-6M	CBDT-9/9-6M	900	2.20			0.25	2100	60	61	42	21
CJBDT-10/10-4T	CBDT-10/10-4T	1420	2.90	1.70		0.55	3450	67	68	49	26
CJBDT-10/10-4/8T	CBDT-10/10-4/8T	1440 / 710		1.76 / 0.76		0.55 / 0.15	3450 / 1750	67 / 54	68 / 55	50	27
CJBDT-10/10-4M	CBDT-10/10-4M	1410	4.10			0.55	3450	67	68	49	25
CJBDT-10/10-6T	CBDT-10/10-6T	920	1.50	0.90		0.25	2250	63	64	47	24
CJBDT-10/10-6M	CBDT-10/10-6M	900	2.20			0.25	2250	63	64	47	23
CJBDT-12/12-6T-1	CBDT-12/12-6T-1	940	4.40	2.60		0.75	4800	64	65	69	37
CJBDT-12/12-6/12T-1	CBDT-12/12-6/12T-1	935 / 430		2.50 / 1.03		0.75 / 0.15	4800 / 2600	64 / 52	65 / 53	72	41
CJBDT-12/12-6M-1	CBDT-12/12-6M-1	920	5.80			0.75	4800	64	65	69	37
CJBDT-12/12-6T-1.5	CBDT-12/12-6T-1.5	945	6.40	3.70		1.10	6200	65	67	71	39
CJBDT-12/12-6/12T-1,5	CBDT-12/12-6/12T-1,5	940 / 450		3.30 / 1.20		1.10 / 0.18	6200 / 3250	65 / 53	67 / 55	75	44
CJBDT-12/12-6M-1,5	CBDT-12/12-6M-1,5	920	8.40			1.10	6200	65	67	71	39
CJBDT-15/15-6T	CBDT-15/15-6T	950	10.30	5.90		2.20	8250	67	68	110	68
CJBDT-15/15-6/12T	CBDT-15/15-6/12T	940 / 470		5.60 / 2.20		2.20 / 0.37	8250 / 4600	67 / 54	68 / 55	116	74
CJBDT-18/18-6T	CBDT-18/18-6T	970		11.00	6.35	4.00	11800	67	69	175	109
CJBDT-18/18-6/12T	CBDT-18/18-6/12T	970 / 480		11.30 / 4.20		4.00 / 0.65	11800 / 6600	67 / 54	69 / 56	183	117
CJBDT-20/20-6T	CBDT-20/20-6T	970		14.00		5.50	14300	68	70	247	151
CJBDT-20/20-6/12T	CBDT-20/20-6/12T	970 / 480		13.70 / 5.60		5.50 / 1.00	14300 / 9700	68 / 55	70 / 57	255	159
CJBDT-22/22-6T	CBDT-22/22-6T	960		18.40	10.60	7.50	18050	69	71	309	190
CJBDT-22/22-6/12T	CBDT-22/22-6/12T	970 / 480		19.00 / 8.00		7.50 / 1.40	18050 / 11800	69 / 56	71 / 58	319	200

## Acoustic features

The specified values are determined according to free field measurements of pressure and sound levels in dB(A) at an equivalent distance of twice the fan's span plus the impeller's diameter, with a minimum of 1.5 m.

Sound power Lw(A) spectrum in dB(A) via frequency band in Hz.

CBDT Model	63	125	250	500	1000	2000	4000	8000	CJBDT Model	63	125	250	500	1000	2000	4000	8000
9/9-4	46	56	64	68	73	72	69	61	9/9-4	51	66	70	69	68	65	65	55
9/9-6	43	54	59	66	67	67	62	56	9/9-6	47	62	66	65	64	61	61	51
9/9-8	34	45	51	57	60	59	55	48	9/9-8	44	51	57	57	54	50	53	48
10/10-4	48	58	66	70	75	74	71	63	10/10-4	54	69	73	72	71	68	68	58
10/10-6	46	57	62	69	70	70	65	59	10/10-6	50	65	69	68	67	64	64	54
10/10-8	36	47	53	59	62	61	57	50	10/10-8	47	54	60	60	57	53	56	51
12/12-6-1	47	58	63	70	71	71	66	60	12/12-6-1	51	66	70	69	68	65	65	55
12/12-6-1,5	49	60	65	72	73	73	68	62	12/12-6-1,5	52	67	71	70	69	66	66	56
12/12-12-1	34	45	51	57	60	59	55	48	12/12-12-1	45	52	58	58	55	51	54	49
12/12-12-1,5	46	53	59	59	56	52	55	50	12/12-12-1,5	46	53	59	59	56	52	55	50
15/15-6	63	72	74	76	71	70	64	55	15/15-6	63	72	74	76	71	70	64	55
15/15-12	51	54	63	60	58	60	60	48	15/15-12	51	54	63	60	58	60	60	48
18/18-6	64	74	76	78	73	72	66	57	18/18-6	64	74	76	78	73	72	66	57
18/18-12	53	56	65	62	60	62	62	50	18/18-12	53	56	65	62	60	62	62	50
20/20-6	67	77	79	80	76	74	69	60	20/20-6	67	77	79	80	76	74	69	60
20/20-12	55	59	68	65	63	65	64	53	20/20-12	55	59	68	65	63	65	64	53
22/22-6	69	79	81	83	78	77	71	62	22/22-6	69	79	81	83	78	77	71	62
22/22-12	58	61	70	67	65	67	67	55	22/22-12	58	61	70	67	65	67	67	55

## Dimensions in mm

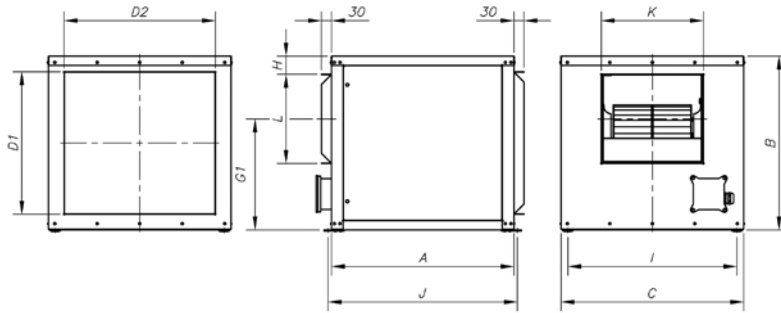

	A	B	C	D1	D2	G1	H	I	J	K	L
CJBDT-9/9	550	522	550	428	456	333,5	54,5	509	570	308	268
CJBDT-10/10	600	575	600	480	505	361,5	65,5	559	620	334	296
CJBDT-12/12	650	650	700	555	605	418	57,5	659	670	395	349
CJBDT-15/15	755	755	800	660	705	485	64	759	775	478	412
CJBDT-18/18	1000	900	1000	804	904	585	69,5	934	1041	550	491
CJBDT-20/20	1200	1175	1100	1070	1000	701	167,5	1040	1247	610	613
CJBDT-22/22	1280	1250	1250	1154	1154	739,5	158,8	1190	1327	664	704

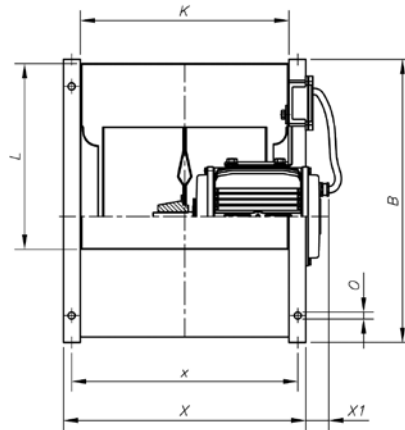
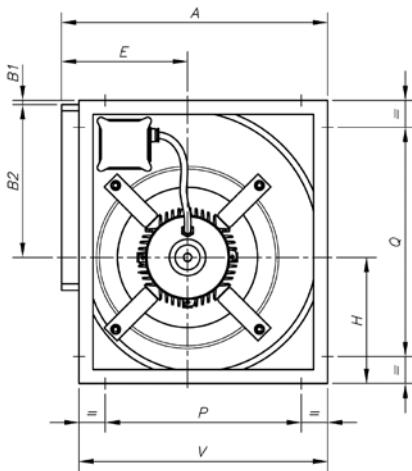

Situación caja de bornes:

CBDT-9/9  
10/10  
12/12  
15/15

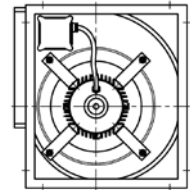

CBDT-18/18  
20/20  
22/22

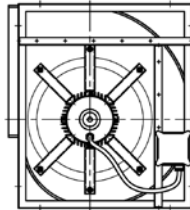

	A	B	B1	B2	E	H	K	L	P	Q	V	X	X1	x	O
CBDT-9/9	390	402	1,5	218	183	181	300	263	280	280	358	360	49	332	9x17
CBDT-10/10	430	448	2	246	202	204	326	292	326	326	398	388	33	360	9x17
CBDT-12/12	501	534	4	290	230	239,5	387	342	384	384	470	448	57	420	9x17
CBDT-15/15	584	630	-	348	265	280	473	405	460	460	550	535	58	507	9x17
CBDT-18/18	694	756	4	415	323	336	540	482	553	608	665	600	85	570	9x17
CBDT-20/20	839	935	6	523	372	406	602	604	595	735	795	682	58	642	12
CBDT-22/22	907	1019	6	571	399	442	655	695	663	819	863	735	105	695	12

Characteristic curves

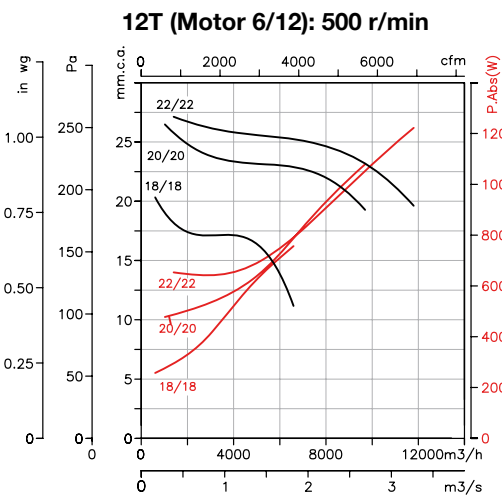
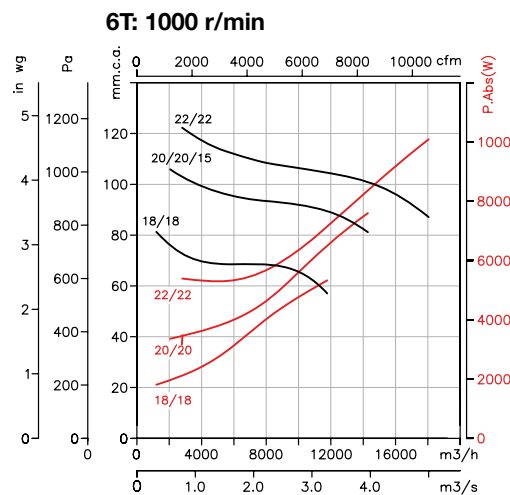
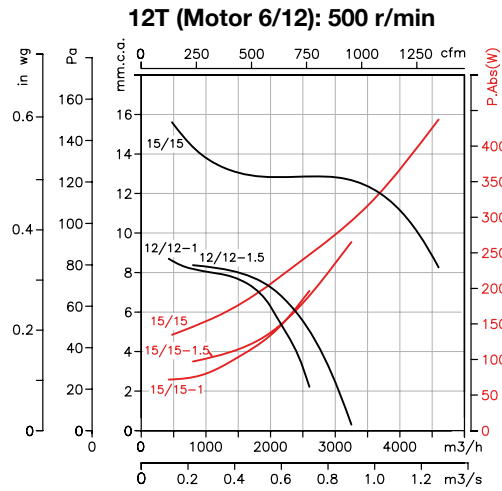
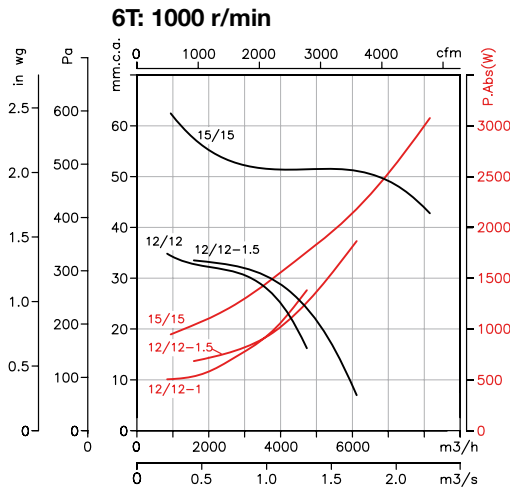
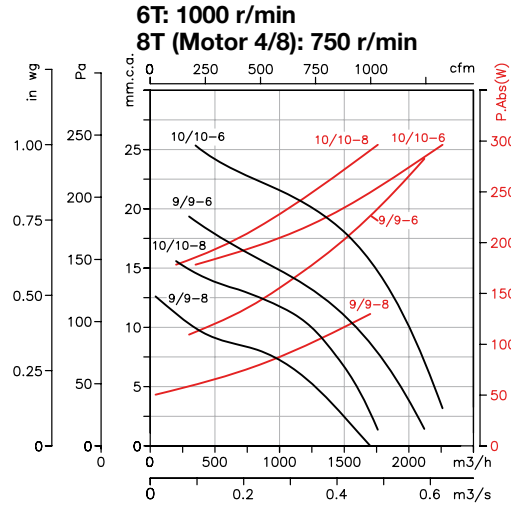
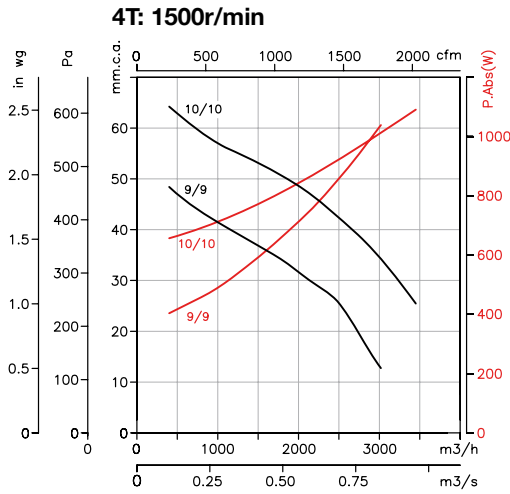

Accessories

See accessories section



# TCR

## 400°C/2h and 300°C/1h centrifugal fans with backward-curved impeller.



High-performance and robust backward-curved impeller.

Robust centrifugal medium-pressure single-inlet fans to work inside fire danger zones at 400°C/2h, fitted with impellers backward-curved blades.

### Fan:

- Steel sheet casing
- Impeller with backward-curved blades made from robust sheet steel and heat-resistant paint
- Approval according to Standard EN-12101-3-2002, certificate no.: 0370-CPD-0384

### Motor:

- Class H motors, ongoing use S1 and emergency use S2, with ball bearings and IP55 protection
- Three-phase 230/400V.-50Hz. (up to 4CV.) and 400/690V.-50Hz. (power over 4CV.)
- Max. temperature of air for transport: S1 Service -20°C+ 120°C for ongoing use, S2 Service 300°C/2h, 400°C/2h

### Finish:

- Anticorrosive finish in polyester resin, polymerised at 190°C, after alkaline degreasing and phosphate-free pre-treatment.

### On request:

- Fans with 200°C/2h one- or two-speed motor



## Order code

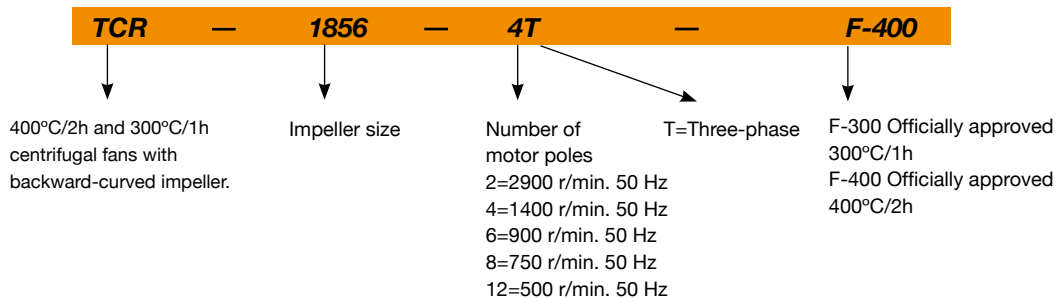

## Positions

LG 270 standard supply



## Technical characteristics

Model	Speed (r/min)	Maximum admissible current (A)			Power installed (kW)	Airflow maximum (m³/h)	Sound pressure level dB(A)	Approx. weight (Kg)
		230V	400V	690V				
TCR-1240-4T	1420	3.70	2.10		0.75	5800	71	76
TCR-1445-4T	1420	4.70	2.70		1.10	8030	72	98
TCR-1650-4T	1425	6.60	3.80		1.50	10500	74	118
TCR-1650-6T	940	4.40	2.60		0.75	7410	64	118
TCR-1856-4T	1430	11.40	6.60		3.00	15150	79	158
TCR-1856-6T	945	6.40	3.70		1.10	10050	70	150
TCR-2063-4T	1460		13.00	7.50	5.50	24450	80	257
TCR-2063-6T	945	7.40	4.30		1.50	16100	71	212
TCR-2271-4T	1460		22.00	12.70	11.00	34610	85	380
TCR-2271-6T	970	14.60	8.40		3.00	22750	76	313

**Acoustic features**

The specified values are determined according to free field measurements of pressure and sound levels in dB(A) at an equivalent distance of twice the fan's span plus the turbine's diameter, with a minimum of 1.5 m.

Sound power Lw(A) spectrum in dB(A) via frequency band in Hz.

Model	63	125	250	500	1000	2000	4000	8000	Model	63	125	250	500	1000	2000	4000	8000
1240	56	70	76	79	79	80	70	59	1856-6	61	69	81	83	80	81	71	60
1445	59	72	78	83	80	83	78	64	2063-4	80	85	91	93	91	88	81	73
1650-4	64	74	82	84	83	85	76	66	2063-6	69	70	82	82	81	83	73	63
1650-6	53	65	72	77	73	69	62	54	2271-4	83	84	93	96	98	99	95	82
1856-4	69	78	91	87	90	91	85	71	2271-6	73	73	87	86	90	90	79	68

**Dimensions in mm**

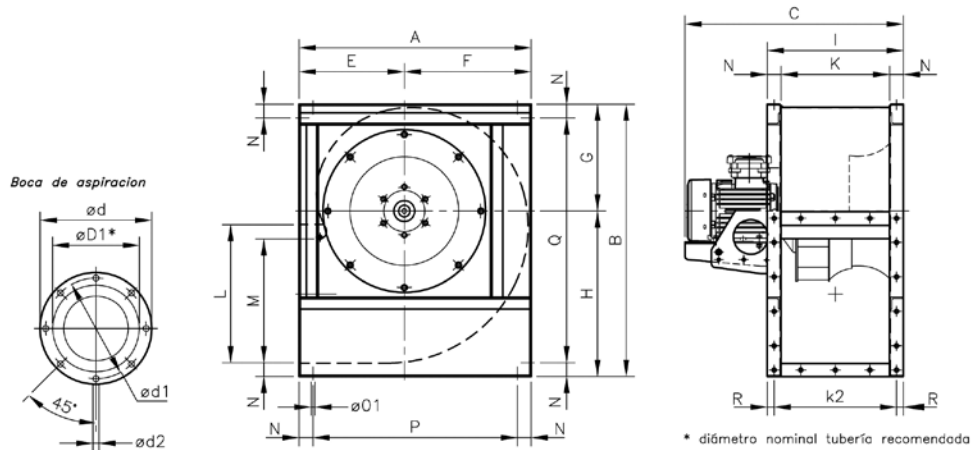

Model	A	B	C	ØD1*	Ød	Ød1	Ød2	E	F	G	H	M	N	Ø01	P	Q	R
1240-4T	673	790	634	400	472	444	M.8	305	368	310	480	358.5	40	11	593	710	20
1445-4T	765	880	727	450	522	494	M.8	350	415	339	541	407	45	11	675	790	20
1650-4T	832	970	770.5	500	582	555	M.10	375	457	378	592	445	45	13	742	880	20
1650-6T	832	970	770.5	500	582	555	M.10	375	457	378	592	445	45	13	742	880	20
1856-4T	925	1084	857.5	560	645	615	M.10	415	510	424	660	493	50	13	825	984	25
1856-6T	925	1084	828	560	645	615	M.10	415	510	424	660	493	50	13	825	984	25
2063-4T	1037	1218	955	630	720	688	M.10	465	572	477	741	530	60	13	917	1098	30
2063-6T	1037	1218	932	630	720	688	M.10	465	572	477	741	530	60	13	917	1098	30
2271-4T	1173	1375	1149	710	800	768	M.12	525	648	538	837	603.5	65	13	1043	1245	32.5
2271-6T	1173	1375	1112	710	800	768	M.12	525	648	538	837	603.5	65	13	1043	1245	32.5

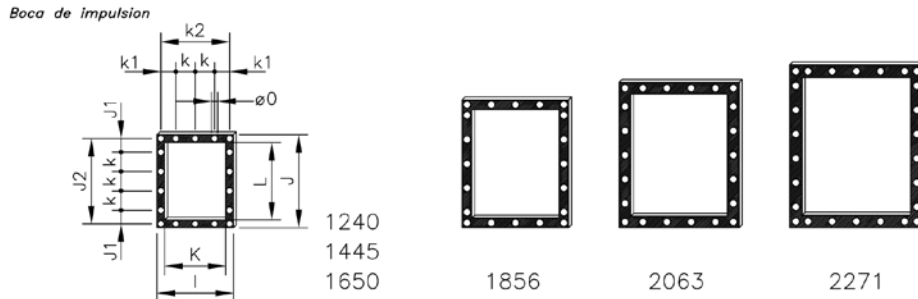

Model	I	J	J1	J2	K	k	k1	k2	L	Ø0
1240	395	480	70	440	315	100	77.5	355	400	11
1445	445	540	99	498	355	100	102.5	405	450	11
1650	490	590	87.5	550	400	125	100	450	500	13
1856	550	660	55	610	450	125	125	500	560	13
2063	620	750	95	690	500	125	92.5	560	630	13
2271	690	840	75	775	560	125	62.5	625	710	13

**Characteristic curves**

Q = Airflow in m<sup>3</sup>/h, m<sup>3</sup>/s and cfm.

Pe= Static pressure in mm.w.c., Pa and inwg.

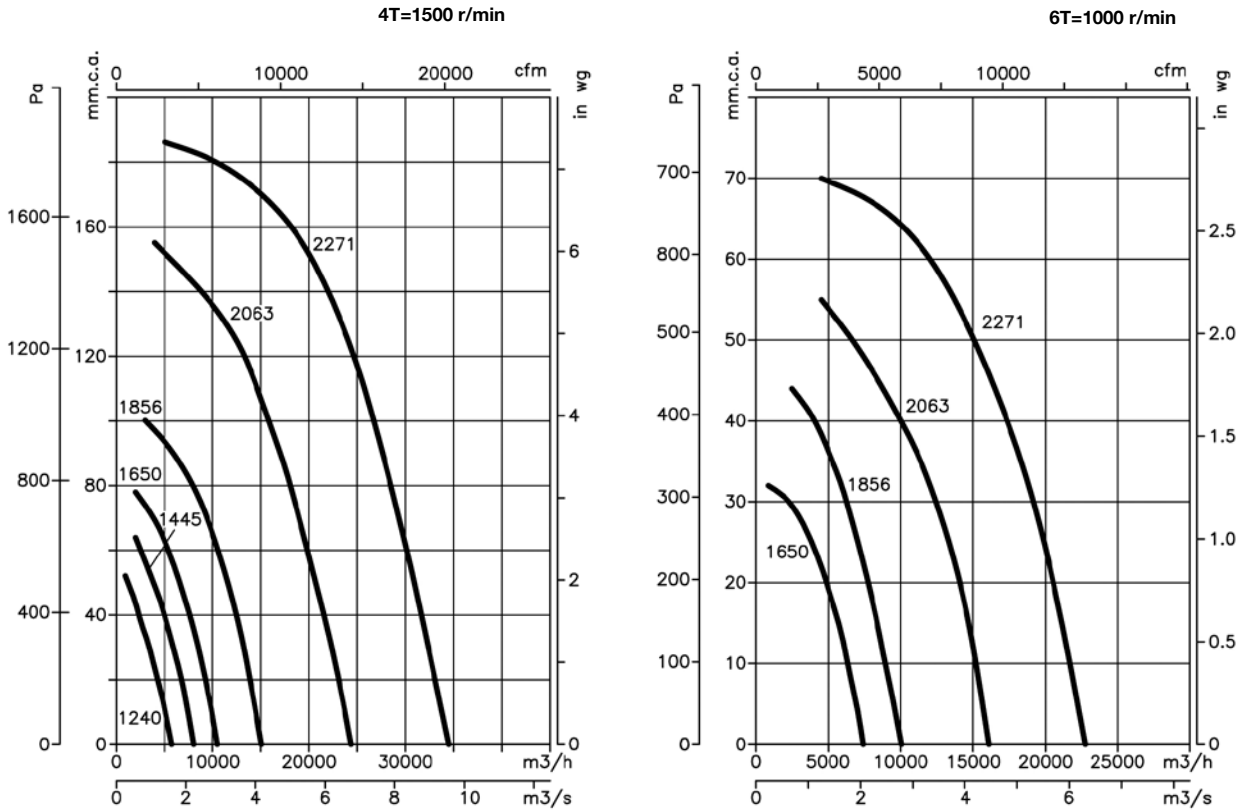

**Accessories**

See accessories section



# CTMP



High-performance multi-blade impeller and robust centres

## 400°C/2h and 300°C/1h centrifugal fans with multi-blade impeller

Centrifugal medium-pressure single-inlet fans to work inside fire danger zones at 400°C/2h, fitted with sheet steel casing and impeller.

### Fan:

- Steel sheet casing
- Impeller with forward-facing blades made from galvanised sheet steel
- Approval according to Standard EN-12101-3-2002, certificate no.: 0370-CPD-0397

### Motor:

- Class H motors, ongoing use S1 and emergency use S2, with ball bearings and IP55 protection
- Three-phase 230/400V.-50Hz. (up to 4CV.) and 400/690V.-50Hz. (power over 4CV.)
- Max. temperature of air for transport: S1 Service -20°C+ 120°C for ongoing use, S2 Service 300°C/2h, 400°C/2h

### Finish:

- Anticorrosive finish in polyester resin, polymerised at 190°C, after alkaline degreasing and phosphate-free pre-treatment.

### On request:

- Fans with two-speed motor.



## Order Code

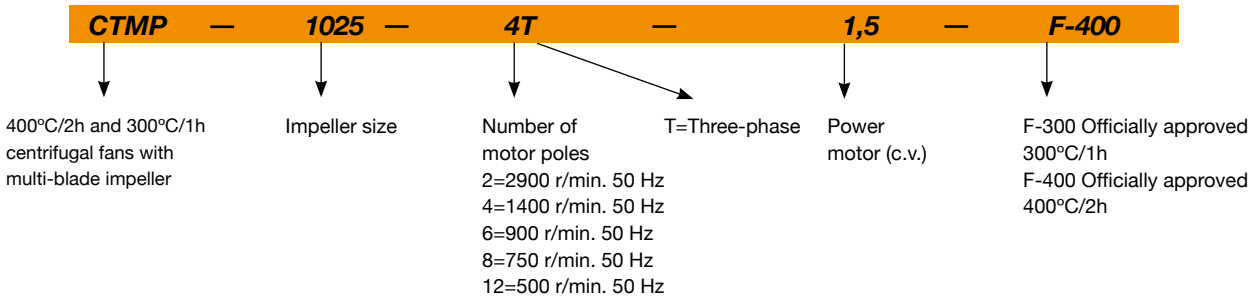

## Positions

LG 270 standard supply  
LG 180 and RD 180 positions on request and with special fixing measures.

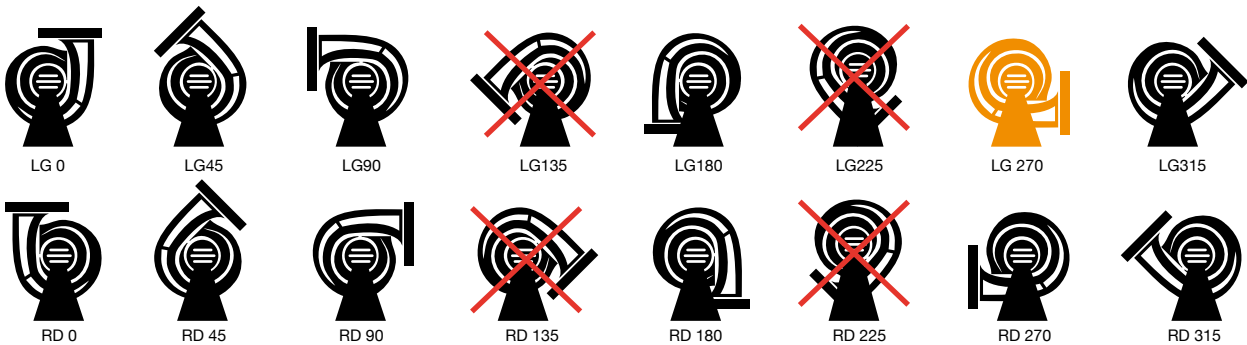

**Technical characteristics**

Model	Speed (r/min)	Maximum admissible current (A)			Power installed (kW)	Airflow maximum (m³/h)	Sound pressure level dB(A)	Approx. weight (Kg)
		230V	400V	690V				
CTMP-922-4T	1420	3.70	2.10		0.75	2750	66	30
CTMP-1025-4T-1,5	1420	4.70	2.70		1.10	3400	70	36
CTMP-1025-4T-2	1425	6.60	3.80		1.50	3900	72	38
CTMP-1128-4T-3	1435	9.20	5.30		2.20	5000	74	47
CTMP-1128-4T-4	1430	11.40	6.60		3.00	5500	75	51
CTMP-1128-6T	940	4.40	2.60		0.75	3600	60	41
CTMP-1231-4T-3	1435	9.20	5.30		2.20	4900	73	54
CTMP-1231-4T-4	1430	11.40	6.60		3.00	5750	75	59
CTMP-1231-4T-5,5	1440		8.40	4.80	4.00	6800	77	69
CTMP-1231-6T	945	7.40	4.30		1.50	4500	64	55
CTMP-1435-6T	950	10.30	5.90		2.20	7000	68	70
CTMP-1640-6T	950	10.30	5.90		2.20	7000	71	89
CTMP-1845-6T	950	10.30	5.90		2.20	9000	77	98
CTMP-2050-6T	970		11.00	6.40	4.00	11000	79	152

**Acoustic features**

The specified values are determined according to free field measurements of pressure and sound levels in dB(A) at an equivalent distance of twice the fan's span plus the turbine's diameter, with a minimum of 1.5 m.

Sound power Lw(A) spectrum in dB(A) via frequency band in Hz.

Model	63	125	250	500	1000	2000	4000	8000	Model	63	125	250	500	1000	2000	4000	8000
922	41	51	62	69	73	70	68	61	1231-4-4	53	62	73	80	84	82	80	73
1025-4-1,5	45	55	66	73	77	74	72	65	1231-4-5,5	55	64	75	82	86	84	82	75
1025-4-2	47	57	68	75	79	76	74	67	1231-6	42	51	62	69	73	71	69	62
1128-4-3	49	59	70	77	81	78	76	69	1435	46	55	66	73	77	75	73	66
1128-4-4	50	60	71	78	82	79	77	70	1640	49	58	69	76	80	78	76	69
1128-6	35	45	56	63	67	64	62	55	1845	56	66	77	84	88	86	84	76
1231-4-3	51	60	71	78	82	80	78	71	2050	58	68	79	86	90	88	86	78

**Dimensions in mm**

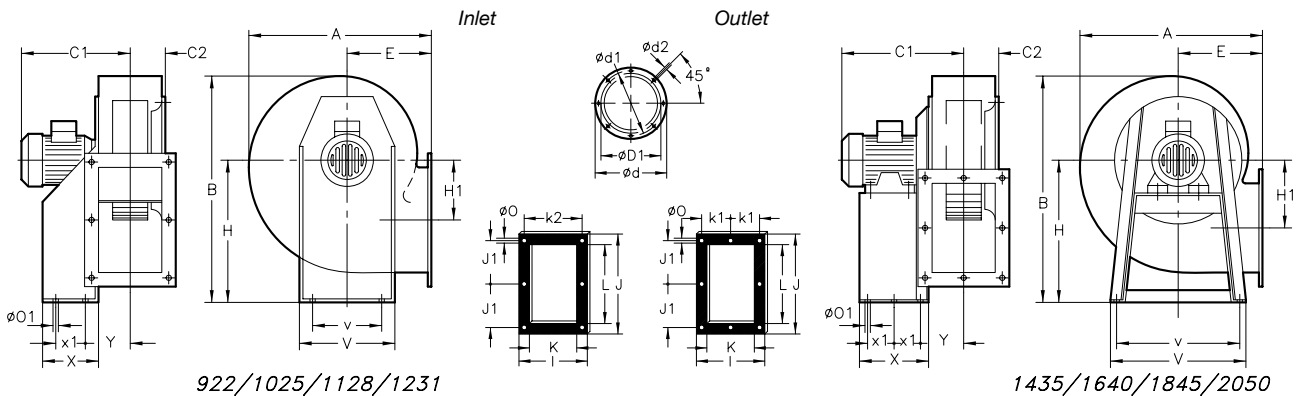

Model	A	B	C1	C2	ØD1*	Ød	Ød1	Ød2	E	H	H1	I	J	J1	L	k1	k2	L	Ø0	Ø01	V	v	X	x1	Y
922	388,5	455	344	73,5	224	278	256	M.8	180	280	134	204	282,5	128	140	-	180	215	9,5	10,5	290	220	114	50	105
1025	427	503	356,5	86	250	305	282	M.8	197	310	144	229	312,5	145	165	-	205	250	9,5	12,5	315	228	134	74	115,5
1128-4T	472	553	439	93,5	280	348	320	M.8	216	340	152	244	364	170	180	-	220	296,5	9,5	12,5	348	245	144	95	122,5
1128-6T	472	553	364	93,5	280	348	320	M.8	216	340	152	244	364	170	180	-	220	296,5	9,5	12,5	348	245	144	95	122,5
1231-3	526	630	449	103,5	315	382	354	M.8	238	390	179,5	264	382,5	180	200	-	240	320	11,5	13	382	322	183	140	126
1231-4	526	630	449	103,5	315	382	354	M.8	238	390	179,5	264	382,5	180	200	-	240	320	11,5	13	382	322	183	140	126
1231-5,5	526	630	449	103,5	315	382	354	M.8	238	390	179,5	264	382,5	180	200	-	240	320	11,5	13	382	322	183	140	126
1231-6T	526	630	449	103,5	315	382	354	M.8	238	390	179,5	264	382,5	180	200	-	240	320	11,5	13	382	322	183	140	126
1435-6T	573,5	715	463	118	355	422	394	M.8	250	445	242,5	292	342,5	159	228	133	-	280	11,5	13	456	420	333	136,5	150
1640-6T	634	799	475	130	400	464	438	M.8	270	495	271	336	404	185	250	150	-	321	11,5	13	500	460	327	133,5	162,5
1845-6T	711	901	492	147	450	515	485	M.8	302	560	305	370	444	202	284	164	-	361	11,5	13	538	502	340	140	179,5
2050-6T	797	987	574,5	162,5	500	565	535	M.10	345	610	313	411	544	250	315	182,5	-	451	11,5	13	635	615	435	188	196

\* Recommended nominal diameter for duct.

**Characteristic curves**

Q = Airflow in m<sup>3</sup>/h, m<sup>3</sup>/s and cfm.

Pe= Static pressure in mm.w.c., Pa and inwg.

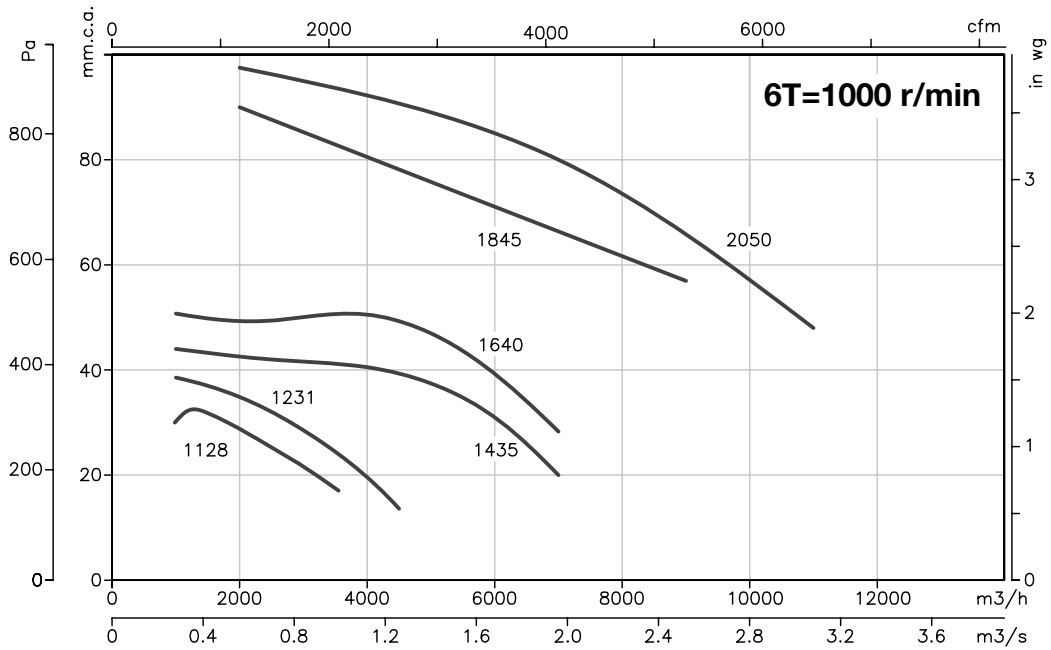
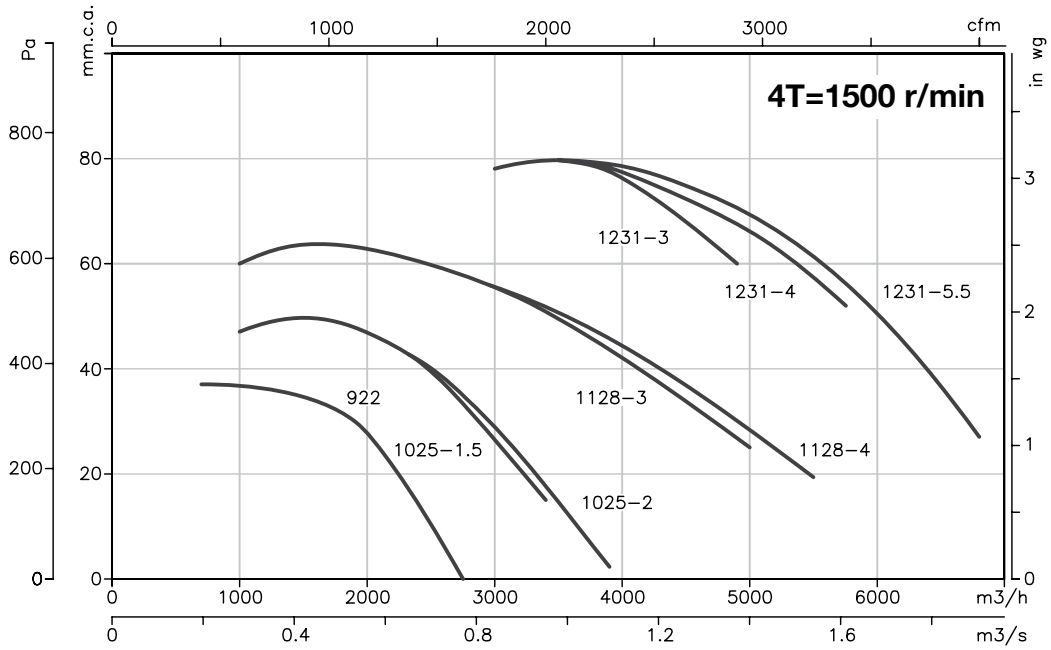

**Accessories**

See accessories section



# CJS

## 400°C/2h and 300°C/1h extraction units with exchangeable hatches



Built with sandwich panels to reduce noise irradiation

Extraction units, with sandwich panel, to work inside fire danger zones at 400°C/2h, with soundproofed box.

### Fan:

- Galvanised sheet steel structure with thermal insulation and soundproofing.
- Impeller with backward-curved blades made from sheet steel
- Exchangeable hatches for outlet on either side.
- Standard models supplied with rectangular outlet, with the TAC accessory, which can be changed for a circular outlet.
- Approval according to Standard EN-12101-3-2002, certificate no.: 0370-CPD-0398
- Linear air circulation



### Motor:

- Class H motors, ongoing use S1 and emergency use S2, with ball bearings, IP55 protection, and one- or two- speed depending on the model.
- Three-phase 230/400V.-50Hz. (up to 4CV.) and 400/690V.-50Hz. (power over 4CV.)
- Max. temperature of air for transport: S1 Service -20°C+ 40°C for ongoing use, S2 Service 300°C/2h, 400°C/2h

### Finish:

- Anticorrosive galvanized sheet steel.

### On request:

- Fans with two-speed motor.
- Special version to work in a vertical position

## Order Code

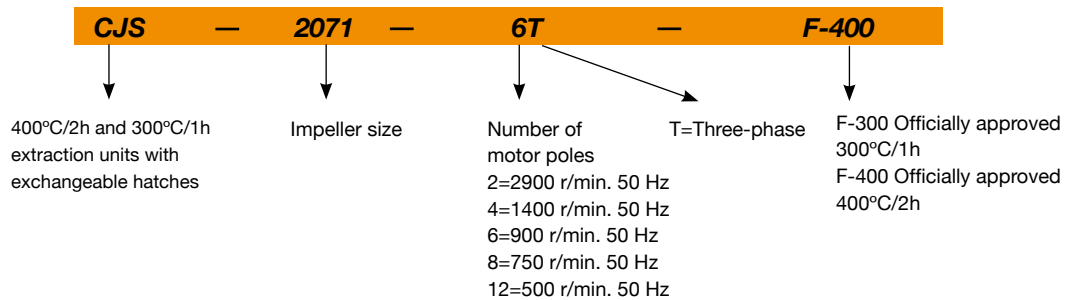

## Technical characteristics

Model	Speed (r/min)	Maximum admissible current (A)			Power installed (kW)	Airflow maximum (m³/h)	Sound pressure level dB(A)	Approx. weight (Kg)
		230V	400V	690V				
CJS-1240-6T	930	3,30	1,90		0,55	2740	59	87
CJS-1850-4T	1425	6,60	3,80		1,50	6450	70	87
CJS-1850-4/8T	1415 / 715		3,60 / 1,50		1,50 / 0,30	6450 / 3225	70 / 55	92
CJS-1850-6T	930	3,30	1,90		0,55	4020	60	85
CJS-2056-4T	1435	9,20	5,30		2,20	9960	72	133
CJS-2056-4/8T	1415 / 715		5,20 / 1,90		2,20 / 0,45	9960 / 4750	72 / 57	146
CJS-2056-6T	940	4,40	2,60		0,75	6500	62	128
CJS-2263-4T	1460		13,00	7,50	5,50	16600	74	196
CJS-2263-4/8T	1455 / 725		12,80 / 4,60		5,50 / 1,10	16600 / 8300	74 / 59	215
CJS-2263-6T	945	6,40	3,70		1,10	8395	64	139

**Technical characteristics**

Model	Speed (r/min)	Maximum admissible current (A)			Power installed (kW)	Airflow maximum (m³/h)	Sound pressure level dB(A)	Approx. weight (Kg)
		230V	400V	690V				
CJS-2071-4T	1460		22,00	12,70	11,00	23800	83	285
CJS-2071-4/8T	1470 / 725		23,20 / 8,70		11,00 / 2,80	23800 / 11900	83 / 68	285
CJS-2071-6T-3	950	10,30	5,90		2,20	11575	68	156
CJS-2071-6T-5,5	970		11,00	6,40	4,00	16800	70	251
CJS-2880-6T	970		11,00	6,40	4,00	17080	71	249

**Acoustic features**

The specified values are determined according to free field measurements of pressure and sound levels in dB(A) at an equivalent distance of twice the fan's span plus the turbine's diameter, with a minimum of 1.5 m.

Sound power Lw(A) spectrum in dB(A) via frequency band in Hz.

Model	63	125	250	500	1000	2000	4000	8000	Model	63	125	250	500	1000	2000	4000	8000
1240	44	58	64	67	67	68	58	47	2263-6	61	67	72	73	77	76	69	62
1850-4	66	72	77	78	81	80	73	68	2263-8	59	64	70	72	70	67	60	52
1850-6	56	62	67	68	71	70	63	58	2271-4	80	81	89	92	95	96	92	78
1850-8	51	57	62	63	66	65	58	53	2271-6-3	65	71	76	77	81	80	73	66
2056-4	67	73	79	79	83	83	75	68	2271-6-5,5	66	65	80	79	83	83	72	61
2056-6	57	63	69	69	73	73	65	58	2271-8	65	66	74	77	80	81	77	63
2056-8	52	58	64	64	68	68	60	53	2880	68	74	79	80	84	83	76	69
2263-4	74	79	85	87	85	82	75	67									

**Dimensions in mm**

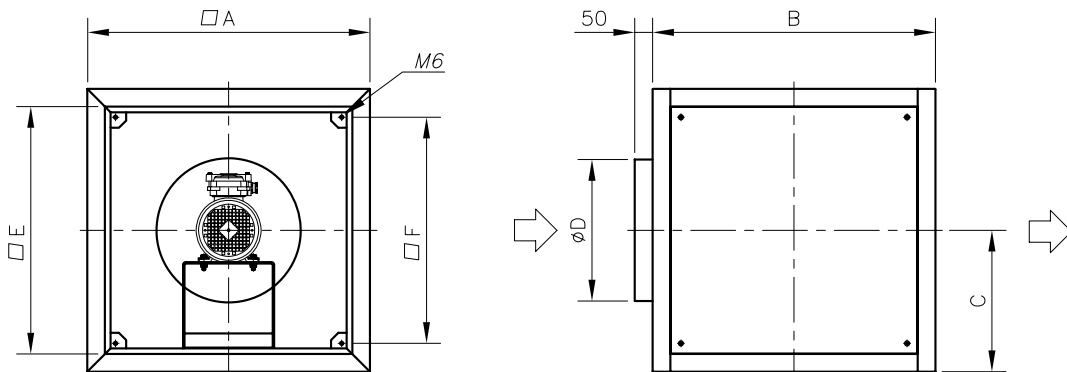

Model	A	B	C	D	E	F
CJS-1240-6T	800	800	400	400	700	640
CJS-1850-4T	800	800	400	400	700	640
CJS-1850-6T	800	800	400	400	700	640
CJS-2056-4T	925	925	462.5	450	825	765
CJS-2056-6T	925	925	462.5	450	825	765
CJS-2263-4T	1000	1000	500	630	900	840
CJS-2263-6T	925	925	462.5	560	825	765
CJS-2071-4T	1060	1060	530	710	960	900
CJS-2071-6T-3	1000	1000	500	630	900	840
CJS-2071-6T-5.5	1060	1060	530	710	960	900
CJS-2880-6T	1060	1060	530	710	960	900

**Characteristic curves**

Q = Airflow in m<sup>3</sup>/h, m<sup>3</sup>/s and cfm.

Pe= Static pressure in mm.w.c., Pa and inwg.

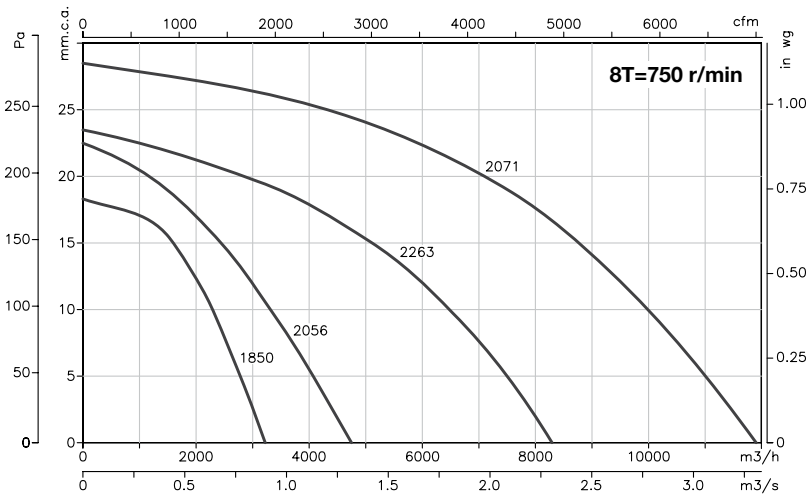
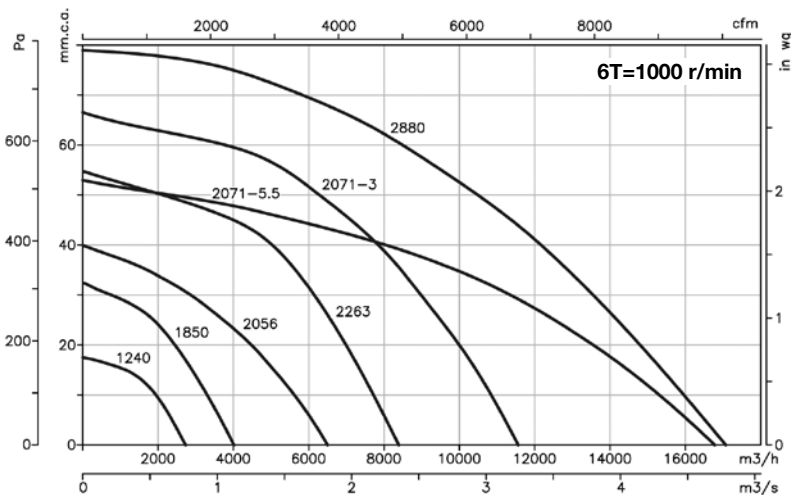
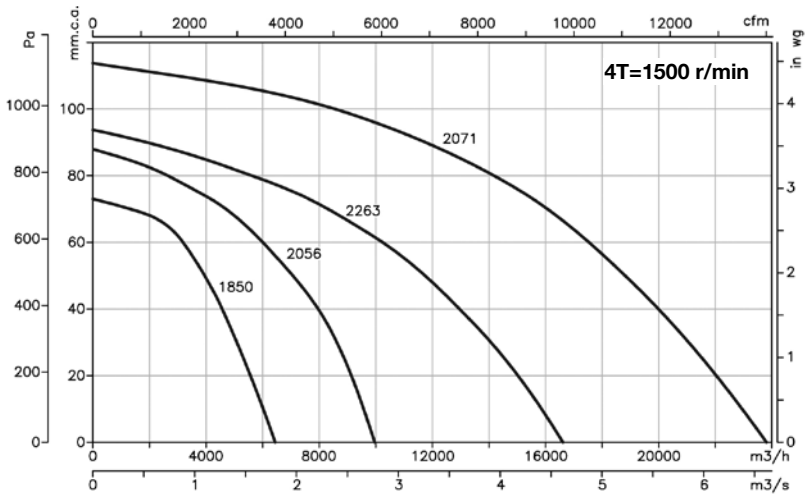

**Accessories**

See accessories section

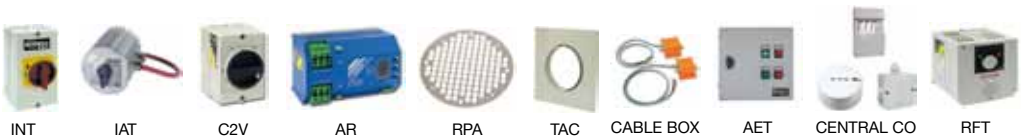

INT

IAT

C2V

AR

RPA

TAC

CABLE BOX

AET

CENTRAL CO

RFT

# CJMD

## 400°C/2h and 300°C/1h extraction units with linear inlet and outlet



The sides on large models are built with pleats to ensure robustness

Extraction units to work inside fire danger zones at 400°C/2h, with soundproofed box.

### Fan:

- Galvanised sheet steel structure with thermal insulation and soundproofing.
- Impeller with backward-curved blades and multi-blade impeller made from sheet steel
- Approval according to Standard EN-12101-3-2002, certificate no.: 0370-CPD-0399
- Linear air circulation

### Motor:

- Class H motors, ongoing use S1 and emergency use S2, with ball bearings and IP55 protection
- Three-phase 230/400V.-50Hz. (up to 4CV) and 400/690V.-50Hz. (power over 4CV)
- Max. temperature of air for transport: S1 Service -20°C+ 40°C for ongoing use, S2 Service 300°C/2h and 400°C/2h

### Finish:

- Anticorrosive galvanized sheet steel.

### On request:

- Fans with two-speed motor.



## Order code

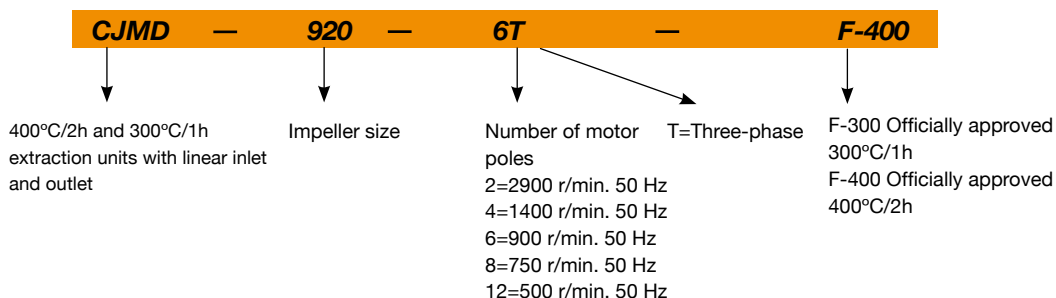

## Technical characteristics

Model	Speed (r/min)	Maximum admissible current (A)			Power installed (kW)	Airflow maximum (m³/h)	Sound pressure level dB(A)	Approx. weight (Kg)
		230V	400V	690V				
CJMD- 600-4T	1420	3.70	2.10		0.75	2750	58	68
CJMD- 665-4T	1420	4.70	2.70		1.10	3400	62	80
CJMD- 730-4T	1435	9.20	5.30		2.20	5000	66	100
CJMD- 730-6T	940	4.40	2.60		0.75	3600	52	95
CJMD- 800-4T	1440		8.40	4.80	4.00	6800	69	132
CJMD- 800-6T	945	7.40	4.30		1.50	4500	56	116
CJMD- 825-6T	940	10.30	5.90		2.20	7000	60	146
CJMD- 885-6T	940	10.30	5.90		2.20	7000	63	164
CJMD- 905-4T	1420	3.70	2.10		0.75	5800	63	133
CJMD- 920-6T	940	10.30	5.90		2.20	9000	69	184
CJMD- 960-4T	1420	4.70	2.70		1.10	8030	64	185
CJMD-1020-4T	1425	6.60	3.80		1.50	10500	66	198
CJMD-1020-6T	940	4.40	2.60		0.75	7410	56	197
CJMD-1160-6T	970		11.00	6.40	4.00	11000	71	263
CJMD-1225-4T	1430	11.40	6.60		3.00	15150	71	279
CJMD-1225-6T	945	6.40	3.70		1.10	10050	62	274
CJMD-1330-4T	1460		13.00	7.50	5.50	24450	72	409
CJMD-1330-6T	945	7.40	4.30		1.50	16100	63	370
CJMD-1550-4T	1460		22.00	12.70	11.00	34610	77	553
CJMD-1550-6T	970	14.60	8.40		3.00	22750	68	501

**Acoustic features**

The specified values are determined according to free field measurements of pressure and sound levels in dB(A) at an equivalent distance of twice the fan's span plus the turbine's diameter, with a minimum of 1.5 m.

Sound power Lw(A) spectrum in dB(A) via frequency band in Hz.

Model	63	125	250	500	1000	2000	4000	8000	Model	63	125	250	500	1000	2000	4000	8000
600-4	33	43	54	61	65	62	60	53	960-4	51	64	70	75	72	75	70	56
665-4	37	47	58	65	69	66	64	57	1020-4	56	66	74	76	75	77	68	58
730-4	41	51	62	69	73	70	68	61	1020-6	45	57	64	69	65	61	54	46
730-6	27	37	48	55	59	56	54	47	1160-6	50	60	71	78	82	80	78	70
800-4	47	56	67	74	78	76	74	67	1225-4	61	70	83	79	82	83	77	63
800-6	34	43	54	61	65	63	61	54	1225-6	53	61	73	75	72	73	63	52
825-6	38	47	58	65	69	67	65	58	1330-4	72	77	83	85	83	80	73	65
885-6	41	50	61	68	72	70	68	61	1330-6	61	62	74	74	73	75	65	55
905-4	48	62	68	71	71	72	62	51	1550-4	75	76	85	88	90	91	87	74
920-6	48	58	69	76	80	78	76	68	1550-6	65	65	79	78	82	82	71	60

**Dimensions in mm**

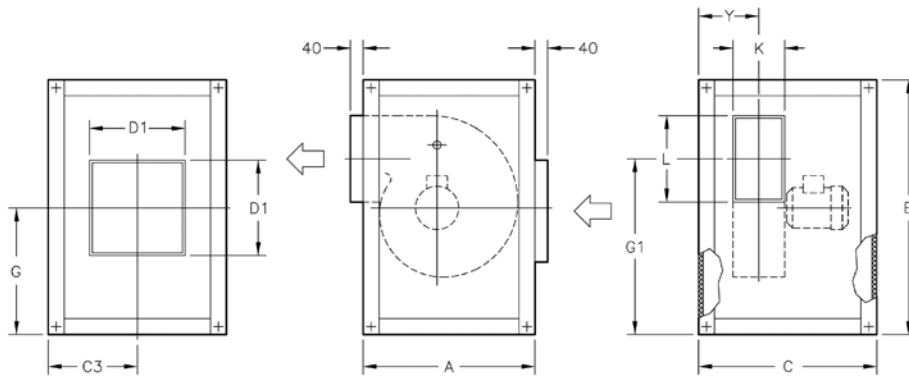

Model	A	B	C	C3	D1	G	G1	K	L	Y
CJMD-600-4T	735	755	604	302	400	378	500	140	215	190
CJMD-665-4T	790	810	678	339	400	405	540	165	250	215
CJMD-730-4T	855	874	748	374	400	437	577	180	295	237
CJMD-730-6T	855	874	748	374	400	437	577	180	295	237
CJMD-800-4T	941	961	798	399	500	481	653	200	320	264
CJMD-800-6T	941	961	798	399	500	481	653	200	320	264
CJMD-825-6T	1039	1059	892	446	500	530	770	230	280	296
CJMD-885-6T	1148	1168	938	469	500	585	849	250	320	330
CJMD-905-4T	970	990	896	448	500	495	636	315	400	398
CJMD-920-6T	1268	1287	954	477	600	644	945	284	360	372
CJMD-960-4T	1060	1080	966	483	60	540	694	355	450	443
CJMD-1020-4T	1150	1170	1038	519	800	585	756	400	500	490
CJMD-1020-6T	1150	1170	1038	519	800	585	756	400	500	490
CJMD-1160-6T	1375	1395	1098	549	800	698	999	315	450	414
CJMD-1225-4T	1204	1284	1258	629	800	642	836	450	560	545
CJMD-1225-6T	1204	1284	1258	629	800	642	836	450	560	545
CJMD-1330-4T	1338	1418	1474	737	800	709	921	500	630	620
CJMD-1330-6T	1338	1418	1474	737	800	709	921	500	630	620
CJMD-1550-4T	1495	1575	1648	824	1000	788	1032	560	710	675
CJMD-550-6T	1495	1575	1648	824	1000	788	1032	560	710	675

**Characteristic curves**

Q = Airflow in m<sup>3</sup>/h, m<sup>3</sup>/s and cfm.

Pe= Static pressure in mm.w.c., Pa and inwg.

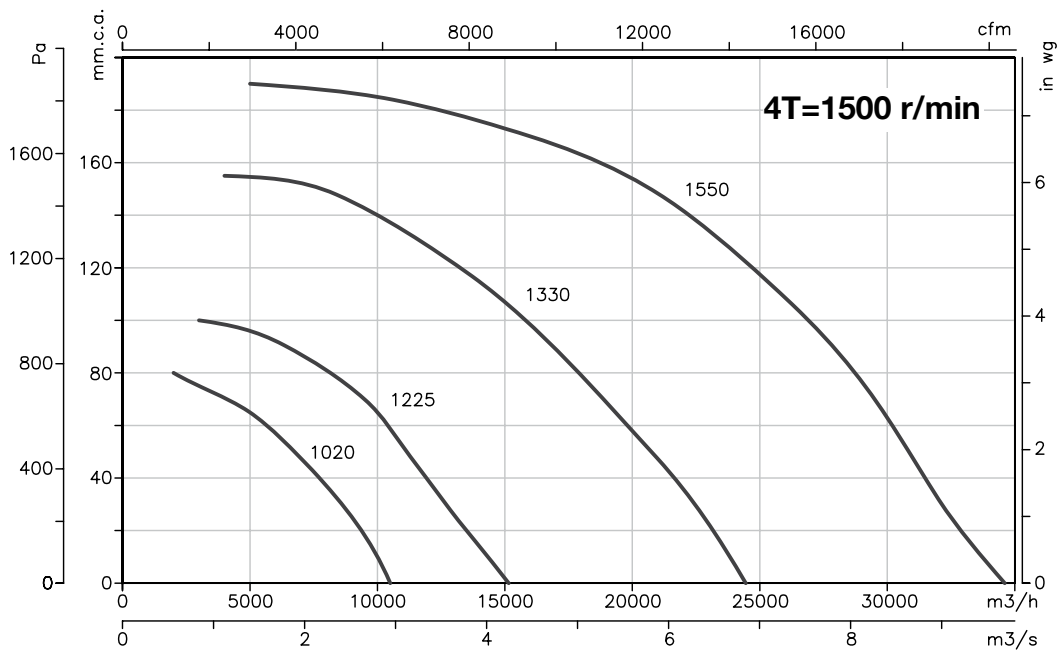
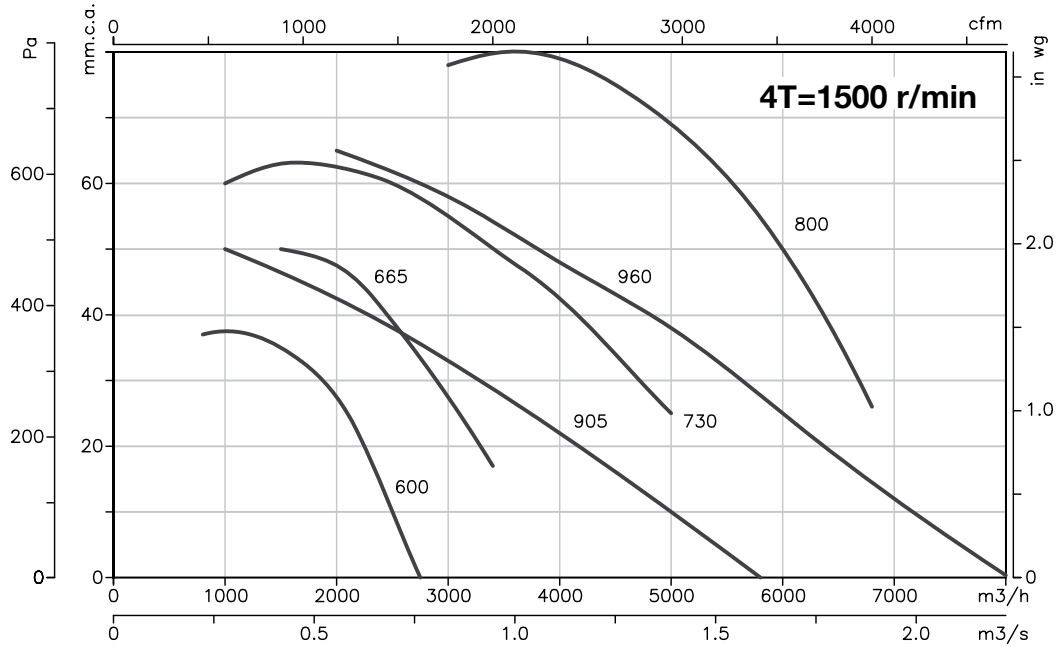

**Characteristic curves**

Q = Airflow in m<sup>3</sup>/h, m<sup>3</sup>/s and cfm.

Pe= Static pressure in mm.w.c., Pa and inwg.

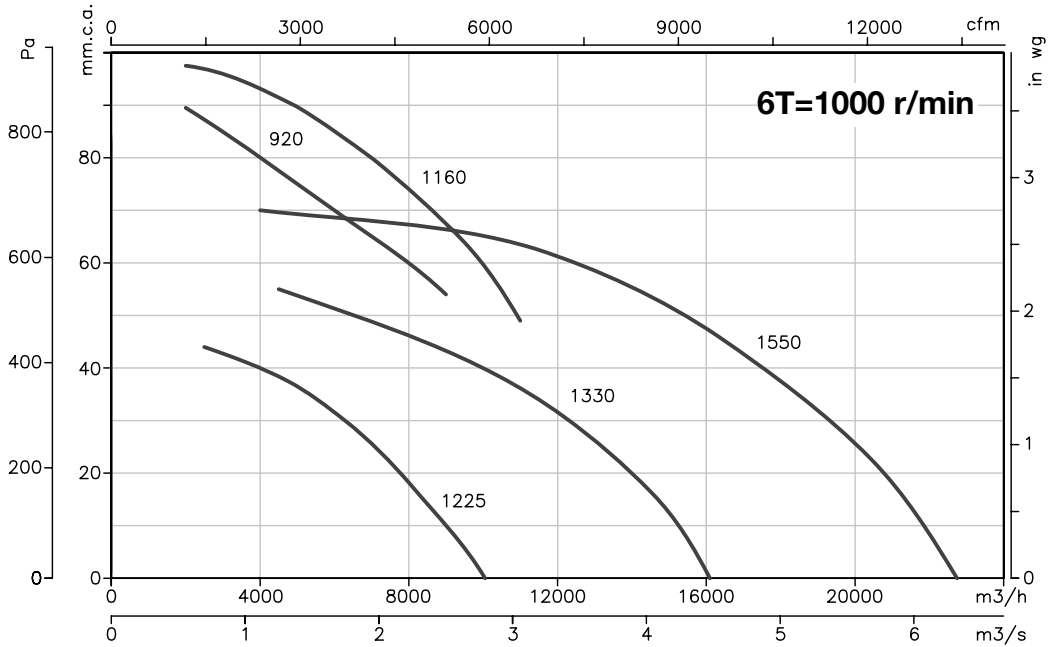
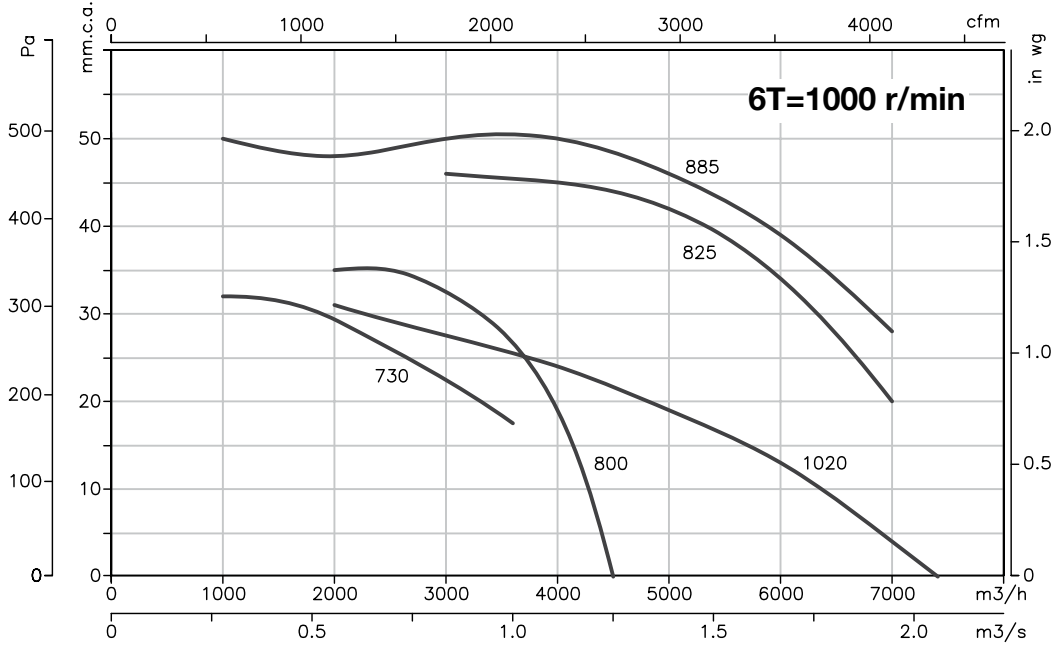

**Accessories**

See accessories section



# TCR/R CJTCR/R

## 400°C/2h centrifugal fans and extraction units with backward-curved impeller

TCR/R: Robust centrifugal single-inlet fans to work outside fire danger zones at 400°C/2h, fitted with impeller with backward-curved blades.

CJTCR/R: Robust single-inlet fans with soundproofed plate to work outside fire danger zones at 400°C/2h.



TCR/R



CJTCR/R

### Fan:

- Steel sheet casing
- Impeller with backward-curved blades made from robust sheet steel and heat-resistant paint
- Approval according to Standard EN-12101-3-2002, certificate no.: 0370-CPD-0400 (TCR/R), and No.: 0370-CPD-0401 (CJTCR/R)

### Motor:

- Class F motors with ball bearings, IP55 protection
- Three-phase 230/400V.-50Hz. (up to 5.5CV.) and 400/690V.-50Hz. (power over 5.5CV.)
- Max. temperature of air for transport: S1 Service -20°C+ 250°C for ongoing use, S2 Service 200°C/2h, 300°C/2h and 400°C/2h

### Finish:

- Anticorrosive finish in polyester resin, polymerised at 190°C, after alkaline degreasing and phosphate-free pre-treatment.
- CJTCR/R: Anticorrosive galvanized sheet steel.

### On request:

- Fans with two-speed motor.
- Belt-driven fans



High-performance and robust backward-curved impeller.

## Order code

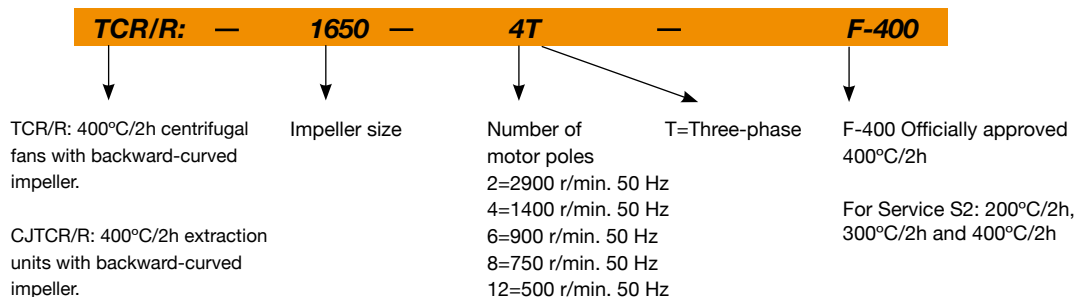

## Technical characteristics

Model	Speed (r/min)	Maximum admissible current (A)			Power installed (kW)	Airflow maximum (m³/h)	Sound pressure level dB(A)		Approx. weight (Kg)	
		230V	400V	690V			TCR/R	CJCR/R	TCR/R	CJTCR/R
TCR/R CJTCR/R 1240-2T	2895	13.16	7.60		4.00	11100	86	81	93	147
TCR/R CJTCR/R 1240-4T	1410	3.29	1.90		0.75	5800	71	66	71	125
TCR/R CJTCR/R 1445-2T	2860		13.90	8.00	7.50	16500	87	82	126	210
TCR/R CJTCR/R 1445-4T	1410	4.49	2.59		1.10	8030	72	67	93	177
TCR/R CJTCR/R 1650-4T	1420	5.98	3.45		1.50	10500	74	68	114	189
TCR/R CJTCR/R 1650-2T	930	4.09	2.36		0.75	7410	64	59	111	186
TCR/R CJTCR/R 1856-4T	1430	11.22	6.48		3.00	15150	79	74	152	273
TCR/R CJTCR/R 1856-6T	930	5.63	3.25		1.10	10050	70	65	145	266
TCR/R CJTCR/R 2063-4T	1450		11.10	6.40	5.50	24450	80	75	225	380
TCR/R CJTCR/R 2063-6T	950	6.79	3.92		1.50	16100	71	66	209	364
TCR/R CJTCR/R 2271-4T	1460		22.00	12.70	11.00	34610	85	79	315	508
TCR/R CJTCR/R 2271-6T	960	11.95	6.90		3.00	22750	76	71	280	473

## Acoustic features

The specified values are determined according to free field measurements of pressure and sound levels in dB(A) at an equivalent distance of twice the fan's span plus the iturbine's diameter, with a minimum of 1.5 m.

Sound power Lw(A) spectrum in dB(A) via frequency band in Hz.

TCR/R Model	63	125	250	500	1000	2000	4000	8000	CJTCR/R Model	63	125	250	500	1000	2000	4000	8000
1240-2	68	83	81	93	90	94	96	83	1240-2	63	78	76	88	85	89	91	78
1240-4	56	40	76	79	79	80	70	59	1240-4	51	65	71	74	74	75	65	54
1445-2	73	85	83	95	93	97	99	89	1445-2	68	80	78	90	88	92	94	84
1445-4	59	72	78	83	80	83	78	64	1445-4	54	67	73	78	75	78	73	59
1650-4	64	74	82	84	83	85	76	66	1650-4	58	68	76	78	77	79	70	60
1650-6	53	65	72	77	73	69	62	54	1650-6	48	60	67	72	68	64	57	49
1856-4	69	78	91	87	90	91	85	71	1856-4	64	73	86	82	85	86	80	66
1856-6	61	69	81	83	80	81	71	60	1856-6	56	64	76	78	75	76	66	55
2063-4	80	85	91	93	91	88	81	73	2063-4	75	80	86	88	86	83	76	68
2063-6	69	70	82	82	81	83	73	63	2063-6	64	65	77	77	76	78	68	58
2271-4	83	84	93	96	98	99	95	82	2271-4	77	78	87	90	92	93	89	76
2271-6	73	73	87	86	90	90	79	68	2271-6	68	68	82	81	85	85	74	63

## Positions

LG 270 standard supply



LG 0



LG 90



LG 180



LG 270



RD 0



RD 90



RD 180



RD 270

Dimensions in mm

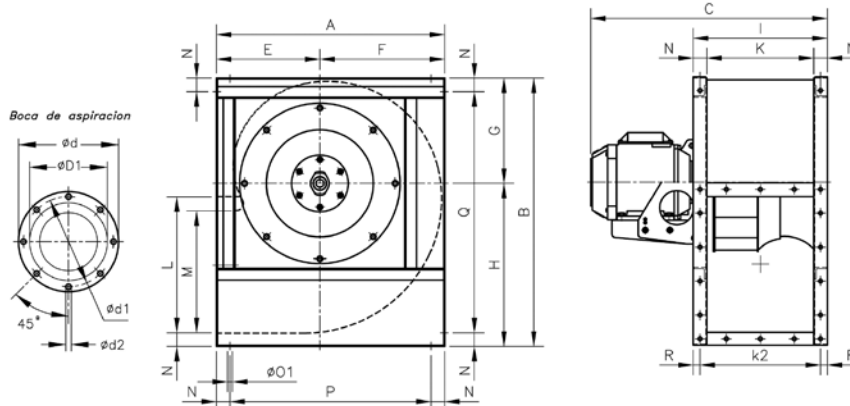

Model	A	B	C	ØD1*	Ød	Ød1	Ød2	E	F	G	H	I	M	N	Ø01	P	Q	R
TCR/R 1240-2T	673	790	734	400	472	444	M.8	305	368	310	480	395	358.5	40	11	593	710	20
TCR/R 1240-4T	673	790	634	400	472	444	M.8	305	368	310	480	395	358.5	40	11	593	710	20
TCR/R 1445-2T	765	880	815	450	522	494	M.8	350	415	339	541	445	407	45	11	675	790	20
TCR/R 1445-4T	765	880	727	450	522	494	M.8	350	415	339	541	445	407	45	11	675	790	20
TCR/R 1650-4T	832	970	770.5	500	582	555	M.10	375	457	378	592	490	445	45	13	742	880	20
TCR/R 1650-6T	832	970	770.5	500	582	555	M.10	375	457	378	592	490	445	45	13	742	880	20
TCR/R 1856-4T	925	1084	857.5	560	645	615	M.10	415	510	424	660	550	493	50	13	825	984	25
TCR/R 1856-6T	925	1084	828	560	645	615	M.10	415	510	424	660	550	493	50	13	825	984	25
TCR/R 2063-4T	1037	1218	955	630	720	688	M.10	465	572	477	741	620	530	60	13	917	1098	30
TCR/R 2063-6T	1037	1218	932	630	720	688	M.10	465	572	477	741	620	530	60	13	917	1098	30
TCR/R 2271-4T	1173	1375	1149	710	800	768	M.12	525	648	538	837	690	603.5	65	13	1043	1245	32.5
TCR/R 2271-6T	1173	1375	1112	710	800	768	M.12	525	648	538	837	690	603.5	65	13	1043	1245	32.5

Outlet

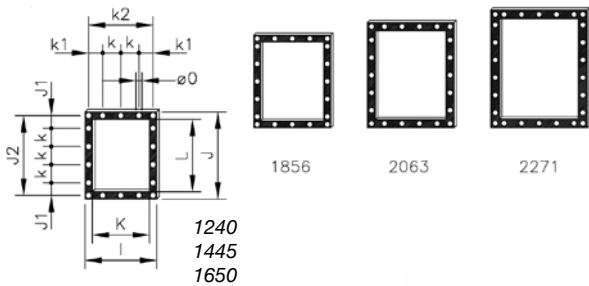

Model	I	J	J1	J2	K	k	k1	k2	L	Ø0
TCR/R-1240	395	480	70	440	315	100	77.5	355	400	11
TCR/R-1445	445	540	99	498	355	100	102.5	405	450	11
TCR/R-1650	490	590	87.5	550	400	125	100	450	500	13
TCR/R-1856	550	660	55	610	450	125	125	500	560	13
TCR/R-2063	620	750	95	690	500	125	92.5	560	630	13
TCR/R-2271	690	840	75	775	560	125	62.5	625	710	13

Standard supply: LG-270

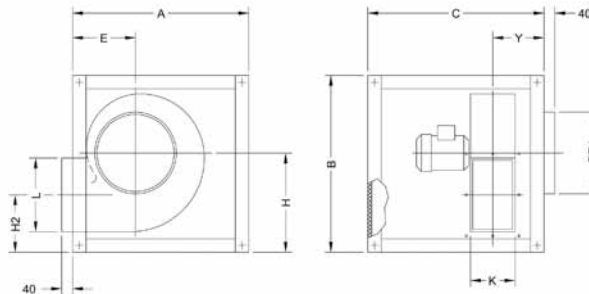

Model	A	B	C	ØD1	E	H	H2	K	L	Y
CJTCR/R-1240	970	970	970	400	312	549	308	315	400	307.5
CJTCR/R-1445	1070	1070	1070	450	357	610	339	355	450	333.5
CJTCR/R-1650	1160	1160	1160	500	382	660	365	400	500	355
CJTCR/R-1856	1260	1260	1050	560	422	727	399	450	560	360
CJTCR/R-2063	1400	1400	1200	630	472	810	444	500	630	395
CJTCR/R-2271	1555	1555	1355	710	532	906	560	560	715	430

## Dimensions in mm

Supplied on request: LG-0

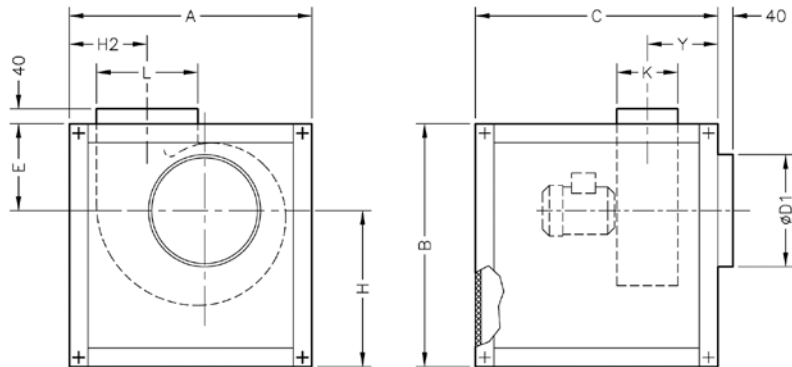

Model	A	B	C	ØD1	E	H	H2	K	L	Y
CJTTCR/R-1240	970	970	970	400	533	437	322	315	400	307.5
CJTTCR/R-1445	1070	1070	1070	450	586	484	367	355	450	333.5
CJTTCR/R-1650	1160	1160	1160	500	634.5	525.5	391.5	400	500	355
CJTTCR/R-1856	1260	1260	1050	560	681.5	578.5	442.5	450	560	360
CJTTCR/R-2063	1400	1400	1200	630	759	641	482	500	630	395
CJTTCR/R-2271	1555	1555	1355	710	838	717	518.5	560	715	430

Supplied on request: LG-90

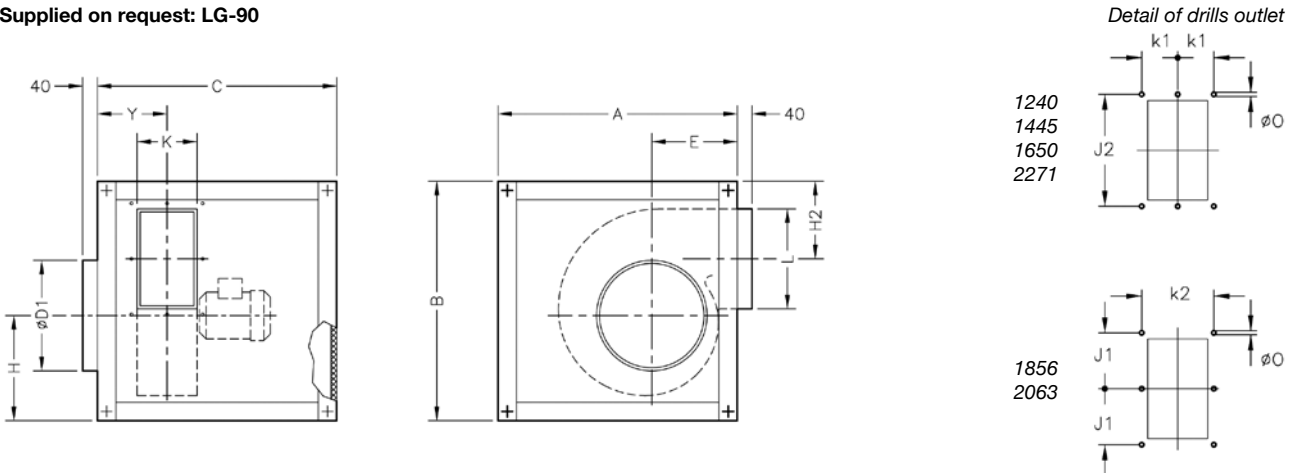

Model	A	B	C	ØD1	E	H	H2	K	L	Y
CJTTCR/R-1240	970	970	970	400	312	379	350	315	400	307.5
CJTTCR/R-1445	1070	1070	1070	450	357	408	391	355	450	333.5
CJTTCR/R-1650	1160	1160	1160	500	382	447	419	400	500	355
CJTTCR/R-1856	1260	1260	1050	560	422	495	438	450	560	360
CJTTCR/R-2063	1400	1400	1200	630	472	546	488	500	630	395
CJTTCR/R-2271	1555	1555	1355	710	532	607	532	560	715	430

Model	k1	k2	J1	J2	Ø0
CJTTCR/R-1240	177.5	-	-	440	11
CJTTCR/R-1445	202.5	-	-	498	11
CJTTCR/R-1650	225	-	-	550	13
CJTTCR/R-1856	-	500	305	-	13
CJTTCR/R-2063	-	560	345	-	13
CJTTCR/R-2271	312.5	-	-	775	13

## Characteristic curves

Q = Airflow in m<sup>3</sup>/h, m<sup>3</sup>/s and cfm.

Pe = Static pressure in mm.w.c., Pa and inwg.

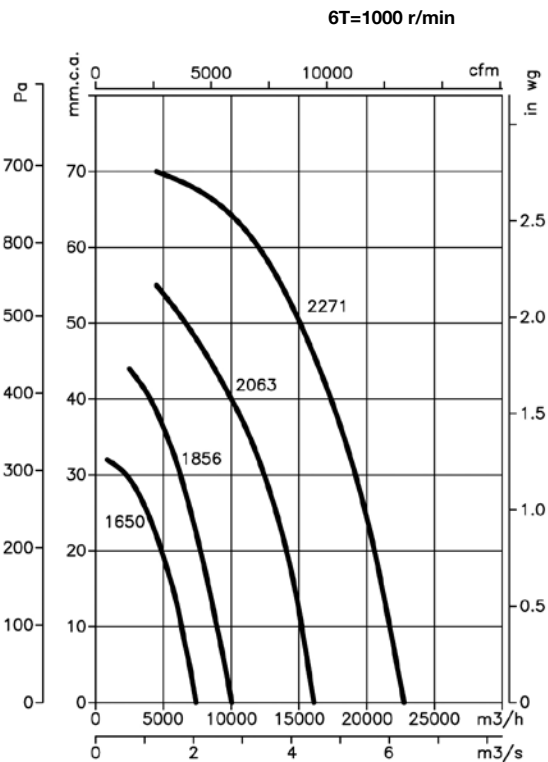
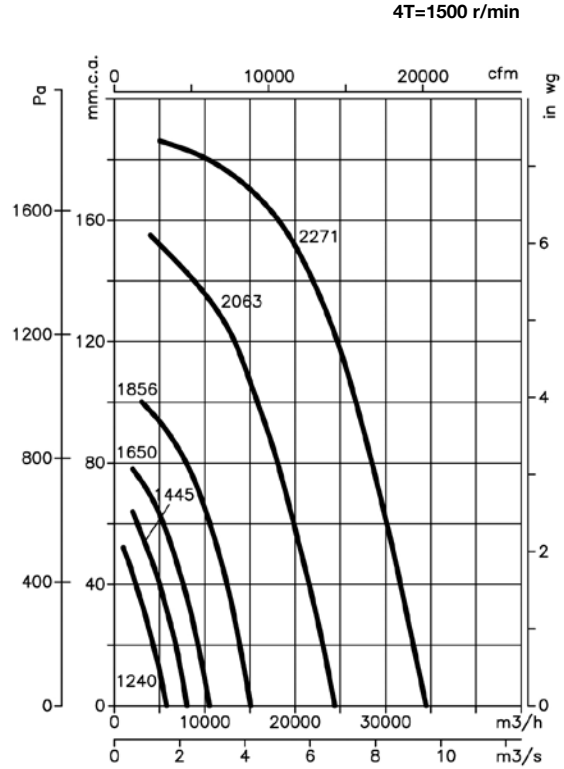
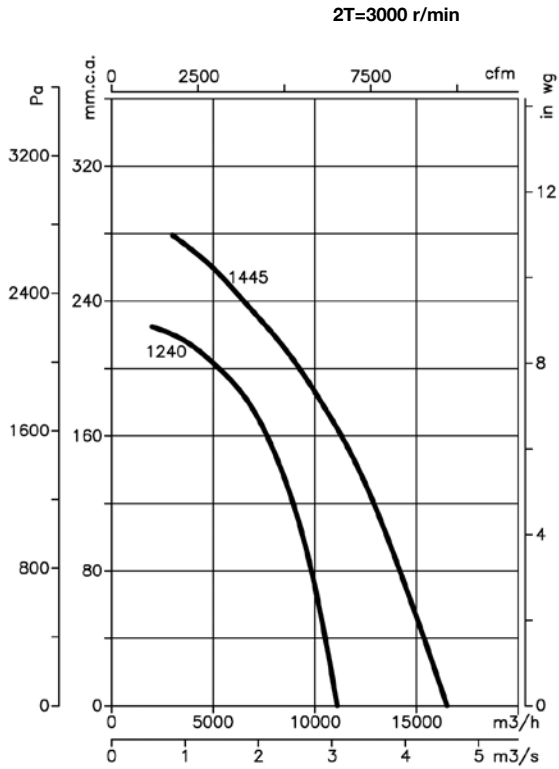

## Accessories

See accessories section



# TCMP CJMP



TCMP



CJMP

## 400°C/2h centrifugal fans and extraction units with multi-blade impeller

TCMP: 400°C/2h centrifugal single-inlet fans to work outside fire danger zones.

CJMP: Extraction single-inlet units with soundproofed plate to work outside fire danger zones at 400°C/2h.

### Fan:

- Steel sheet casing
- Impeller with forward-facing blades made from galvanised sheet steel
- Approval according to Standard EN-12101-3-2002, certificate no.: 0370-CPD-0313 (TCMP), No.: 0370-CPD-0402 (CJMP)

### Motor:

- Class F motors with ball bearings, IP55 protection
- Three-phase 230/400V.-50Hz. (up to 5.5CV.) and 400/690V.-50Hz. (power over 5.5CV.)
- Max. temperature of air for transport: S1 Service -20°C+ 300°C for ongoing use, S2 Service 200°C/2h, 300°C/2h and 400°C/2h

### Finish:

- Anticorrosive finish in polyester resin, polymerised at 190°C, after alkaline degreasing and phosphate-free pre-treatment.
- CJMP: Anticorrosive galvanized sheet steel.

### On request:

- Fans with two-speed motor.
- Belt-driven fans



## Order code

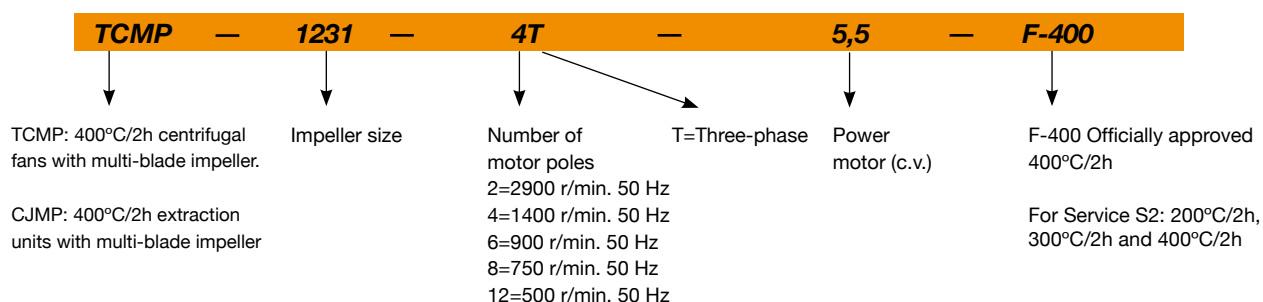

**Technical characteristics**

Model	Speed (r/min)	Maximum admissible current (A)			Power installed (kW)	Airflow maximum (m³/h)	Sound pressure level dB(A)		Approx. weight (Kg)	
		230V	400V	690V			TCMP	CJMP	TCMP	CJMP
TCMP CJMP 820-4T	1350	1,33	0,77		0,25	1670	65	59	11	25
TCMP CJMP 922-4T	1395	2,49	1,44		0,55	2450	66	60	20	55
TCMP CJMP 1025-4T-1,5	1410	4,42	2,55		1,10	3400	70	64	28	69
TCMP CJMP 1025-4T-2	1420	5,89	3,40		1,50	3650	72	66	31	72
TCMP CJMP 1128-4T-3	1420	8,14	4,70		2,20	5000	74	68	38	87
TCMP CJMP 1128-4T-4	1420	11,09	6,40		3,00	5450	75	69	41	90
TCMP CJMP 1128-6T	915	3,55	2,05		0,75	3300	60	55	30	79
TCMP CJMP 1231-4T-3	1420	8,14	4,70		2,20	4750	73	67	45	103
TCMP CJMP 1231-4T-4	1420	11,09	6,40		3,00	5900	75	69	48	106
TCMP CJMP 1231-4T-5,5	1440	14,20	8,20		4,00	6850	77	71	55	113
TCMP CJMP 1231-6T	925	6,75	3,90		1,50	5100	64	59	45	103
TCMP CJMP 1435-4T-4	1420	11,09	6,40		3,00	5550	76	70	55	126
TCMP CJMP 1435-4T-5,5	1440	14,20	8,20		4,00	6250	78	72	62	133
TCMP CJMP 1435-4T-7,5	1455		11,40	6,60	5,50	7200	80	74	72	143
TCMP CJMP 1435-4T-10	1455		15,20	8,80	7,50	9700	82	76	80	151
TCMP CJMP 1435-6T	940	9,01	5,20		2,20	6400	68	63	57	128
TCMP CJMP 1640-4T-5,5	1440	14,20	8,20		4,00	7500	77	71	81	151
TCMP CJMP 1640-4T-7,5	1455		11,40	6,60	5,50	8050	80	74	91	161
TCMP CJMP 1640-4T-10	1455		15,20	8,80	7,50	9700	82	76	99	169
TCMP CJMP 1640-6T	940	9,01	5,20		2,20	8100	71	66	76	146
TCMP CJMP 1845-4T-7,5	1455		11,40	6,60	5,50	8950	82	76	100	181
TCMP CJMP 1845-4T-10	1455		15,20	8,80	7,50	10350	85	79	108	189
TCMP CJMP 1845-6T	940	9,01	5,20		2,20	8350	77	72	85	166
TCMP CJMP 2050-4T-10	1455		15,20	8,80	7,50	9000	83	77	130	233
TCMP CJMP 2050-4T-15	1460		21,50	12,40	11,00	12500	87	81	154	257
TCMP CJMP 2050-4T-20	1460		28,50	16,50	15,00	19000	89	83	166	269
TCMP CJMP 2050-6T	950	16,28	9,40		4,00	11000	79	74	125	228

**Acoustic features:**

The specified values are determined according to free field measurements of pressure and sound levels in dB(A) at an equivalent distance of twice the fan's span plus the turbine's diameter, with a minimum of 1.5 m.

Sound power Lw(A) spectrum in dB(A) via frequency band in Hz.

TCMP Model	63	125	250	500	1000	2000	4000	8000	CJMP Model	63	125	250	500	1000	2000	4000	8000
820	40	50	61	68	72	69	67	60	820	34	44	55	62	66	63	61	54
922	41	51	62	69	73	70	68	61	922	35	45	56	63	67	64	62	55
1025-4-1,5	45	55	66	73	77	74	72	65	1025-4-1,5	39	49	60	67	71	68	66	59
1025-4-2	47	57	68	75	79	76	74	67	1025-4-2	41	51	62	69	73	70	68	61
1128-4-3	49	59	70	77	81	78	76	69	1128-4-3	43	53	64	71	75	72	70	63
1128-4-4	50	60	71	78	82	79	77	70	1128-4-4	44	54	65	72	76	73	71	64
1128-6	35	45	56	63	67	64	62	55	1128-6	30	40	51	58	62	59	57	50
1231-4-3	51	60	71	78	82	80	78	71	1231-4-3	45	54	65	72	76	74	72	65
1231-4-4	53	62	73	80	84	82	80	73	1231-4-4	47	56	67	74	78	76	74	67
1231-4-5,5	55	64	75	82	86	84	82	75	1231-4-5,5	49	58	69	76	80	78	76	69
1231-6	42	51	62	69	73	71	69	62	1231-6	37	46	57	64	68	66	64	57
1435-4-4	54	63	74	81	85	83	81	74	1435-4-4	48	57	68	75	79	77	75	68
1435-4-5,5	56	65	76	83	87	85	83	76	1435-4-5,5	50	59	70	77	81	79	77	70
1435-4-7,5	58	67	78	85	89	87	85	78	1435-4-7,5	52	61	72	79	83	81	79	72
1435-4-10	60	69	80	87	91	89	87	80	1435-4-10	54	63	74	81	85	83	81	74
1435-6	46	55	66	73	77	75	73	66	1435-6	41	50	61	68	72	70	68	61
1640-4-5,5	55	64	75	82	86	84	82	75	1640-4-5,5	49	58	69	76	80	78	76	69
1640-4-7,5	58	67	78	85	89	87	85	78	1640-4-7,5	52	61	72	79	83	81	79	72
1640-4-10	60	69	80	87	91	89	87	80	1640-4-10	54	63	74	81	85	83	81	74
1640-6	49	58	69	76	80	78	76	69	1640-6	44	53	64	71	75	73	71	64
1845-4-7,5	61	71	82	89	93	91	89	81	1845-4-7,5	55	65	76	83	87	85	83	75
1845-4-10	64	74	85	92	96	94	92	84	1845-4-10	58	68	79	86	90	88	86	78
1845-6	56	66	77	84	88	86	84	76	1845-6	51	61	72	79	83	81	79	71
2050-4-10	62	72	83	90	94	92	90	82	2050-4-10	56	66	77	84	88	86	84	76
2050-4-15	66	76	87	94	98	96	94	86	2050-4-15	60	70	81	88	92	90	88	80
2050-4-20	68	78	89	96	100	98	96	88	2050-4-20	62	72	83	90	94	92	90	82
2050-6	58	68	79	86	90	88	86	78	2050-6	53	63	74	81	85	83	81	73

## Dimensions in mm

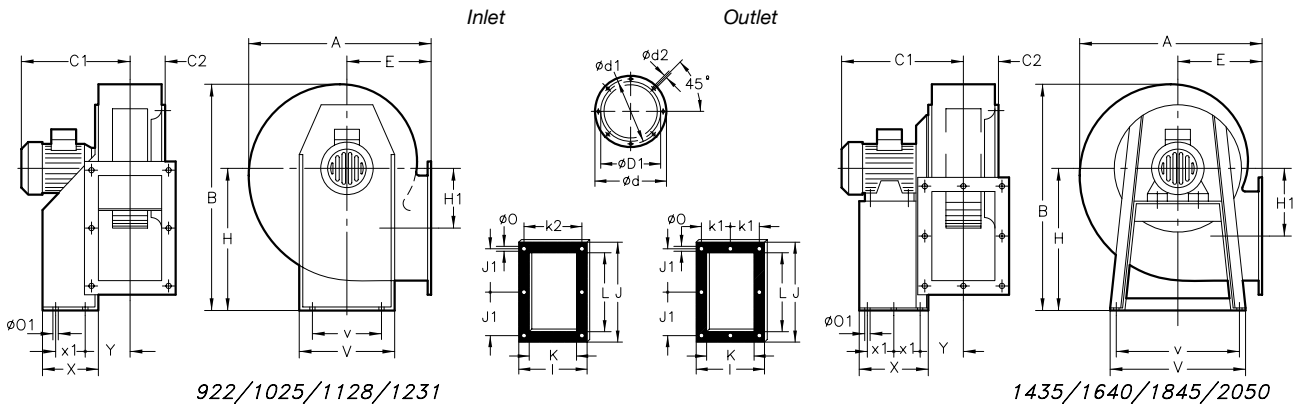

Model	A	B	C1	C2	ØD1*	Ød	Ød1	Ød2	E	H	H1	I	J	J1	K	k1	k2	L	Ø0	Ø01	V	v	X	x1	Y
922	388.5	455	332	73.5	224	278	256	M.8	180	280	134	204	282.5	128	140	-	180	215	9.5	10.5	290	220	114	50	105
1025	427	503	393	86	250	305	282	M.8	197	310	144	229	312.5	145	165	-	205	250	9.5	12.5	315	228	134	74	115.5
1128-4T	472	553	430	93.5	280	348	320	M.8	216	340	152	244	364	170	180	-	220	296.5	9.5	12.5	348	245	144	95	122.5
1128-6T	472	553	400	93.5	280	348	320	M.8	216	340	152	244	364	170	180	-	220	296.5	9.5	12.5	348	245	144	95	122.5
1231-3	526	630	440	103.5	315	382	354	M.8	238	390	179.5	264	382.5	180	200	-	240	320	11.5	13	382	322	183	140	126
1231-4	526	630	440	103.5	315	382	354	M.8	238	390	179.5	264	382.5	180	200	-	240	320	11.5	13	382	322	183	140	126
1231-5.5	526	630	463	103.5	315	382	354	M.8	238	390	179.5	264	382.5	180	200	-	240	320	11.5	13	382	322	183	140	126
1231-6T	526	630	440	103.5	315	382	354	M.8	238	390	179.5	264	382.5	180	200	-	240	320	11.5	13	382	322	183	140	126
1435-4	573.5	715	464	118	355	422	394	M.8	250	445	242.5	292	342.5	159	228	133	-	280	11.5	13	456	420	333	136.5	150
1435-5.5	573.5	715	477	118	355	422	394	M.8	250	445	242.5	292	342.5	159	228	133	-	280	11.5	13	456	420	333	136.5	150
1435-7.5	573.5	715	525	118	355	422	394	M.8	250	445	242.5	292	342.5	159	228	133	-	280	11.5	13	456	420	333	136.5	150
1435-10	573.5	715	525	118	355	422	394	M.8	250	445	242.5	292	342.5	159	228	133	-	280	11.5	13	456	420	333	136.5	150
1435-6T	573.5	715	487	118	355	422	394	M.8	250	445	242.5	292	342.5	159	228	133	-	280	11.5	13	456	420	333	136.5	150
1640-5.5	634	799	499	130	400	464	438	M.8	270	495	271	336	404	185	250	150	-	321	11.5	13	500	460	327	133.5	162.5
1640-7.5	634	799	537	130	400	464	438	M.8	270	495	271	336	404	185	250	150	-	321	11.5	13	500	460	327	133.5	162.5
1640-10	634	799	537	130	400	464	438	M.8	270	495	271	336	404	185	250	150	-	321	11.5	13	500	460	327	133.5	162.5
1640-6T	634	799	499	130	400	464	438	M.8	270	495	271	336	404	185	250	150	-	321	11.5	13	500	460	327	133.5	162.5
1845-4T	711	901	554	147	450	515	485	M.8	302	560	305	370	444	202	284	164	-	361	11.5	13	538	502	340	140	179.5
1845-6T	711	901	516	147	450	515	485	M.8	302	560	305	370	444	202	284	164	-	361	11.5	13	538	502	340	140	179.5
2050-10	797	987	572	162.5	500	565	535	M.10	345	610	313	411	544	250	315	182.5	-	451	11.5	13	635	615	435	188	196
2050-12.5	797	987	624	162.5	500	565	535	M.10	345	610	313	411	544	250	315	182.5	-	451	11.5	13	635	615	435	188	196
2050-15	797	987	677	162.5	500	565	535	M.10	345	610	313	411	544	250	315	182.5	-	451	11.5	13	635	615	435	188	196
2050-20	797	987	677	162.5	500	565	535	M.10	345	610	313	411	544	250	315	182.5	-	451	11.5	13	635	615	435	188	196
2050-6T	797	987	572	162.5	500	565	535	M.10	345	610	313	411	544	250	315	182.5	-	451	11.5	13	635	615	435	188	196

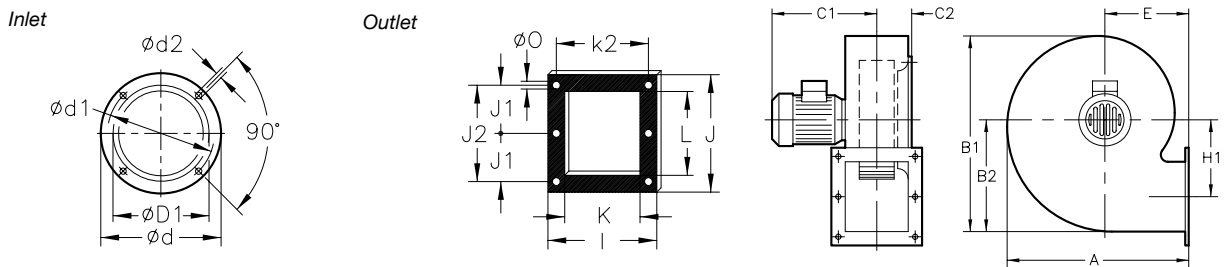

Model	A	B1	B2	C1	C2	ØD1*	Ød	Ød1	Ød2	E	H1	I	J	J1	J2	K	k2	L	Ø0
820-4T	322	377	223	272	68.5	200	247	230	M.6	137.5	137	184	213	94.5	189	130	160	156	9

Dimensions in mm

Standard supply outlet: LG-270

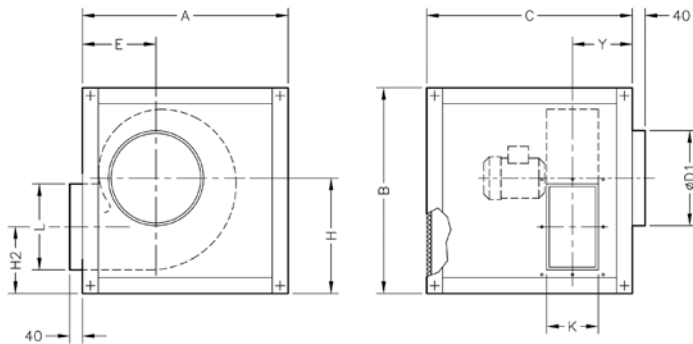

Detail of drills outlet

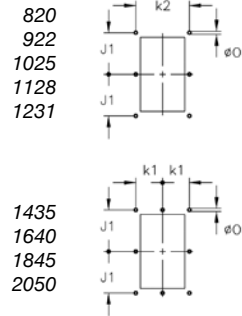

Model	A	B	C	ØD1	E	H	H2	K	L	Y
CJMP-820	400	450	450	200	142	263	126	130	156	112
CJMP-922	610	610	610	224	187	349	215	140	215	176
CJMP-1025	660	660	660	250	204	379	235	165	250	178.5
CJMP-1128	720	720	720	280	223	409	257	180	295	191
CJMP-1231	800	800	800	315	245	459	279.5	200	320	205
CJMP-1435	880	880	880	355	257	514	271.5	230	280	291
CJMP-1640	970	970	970	400	277	564	293	250	320	324
CJMP-1845	1070	1070	1070	450	309	629	324	284	360	357
CJMP-2050	1160	1160	1160	500	352	679	366	315	450	385.5

Model	k1	k2	J1	Ø0
CJMP-820	-	160	94.5	9
CJMP-922	-	180	128	9.5
CJMP-1025	-	205	145	9.5
CJMP-1128	-	220	170	9.5
CJMP-1231	-	240	180	11.5
CJMP-1435	133	-	159	11.5
CJMP-1640	150	-	185	11.5
CJMP-1845	164	-	202	11.5
CJMP-2050	182.5	-	250	11.5

Supplied on request: LG-0

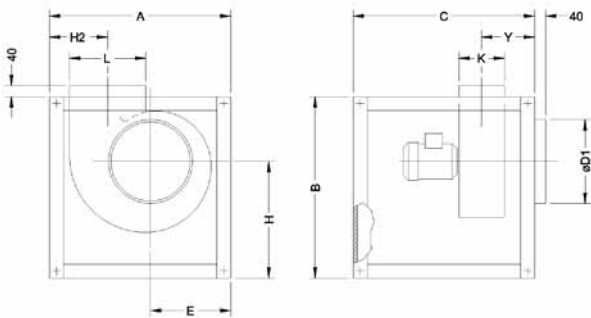

Model	A	B	C	ØD1	E	H	H2	K	L	Y
CJMP-922	610	610	610	224	279	349	197	140	215	176
CJMP-1025	660	660	660	250	302	379	214	165	250	178.5
CJMP-1128	720	720	720	280	335	409	233	180	295	191
CJMP-1231	800	800	800	315	366	459	255	200	320	205
CJMP-1435	880	880	880	355	385	514	253	230	280	291
CJMP-1640	970	970	970	400	412	564	287	250	320	324
CJMP-1845	1070	1070	1070	450	446	629	319	284	360	357
CJMP-2050	1160	1160	1160	500	485	679	362	315	450	383.5

Supplied on request: LG-90

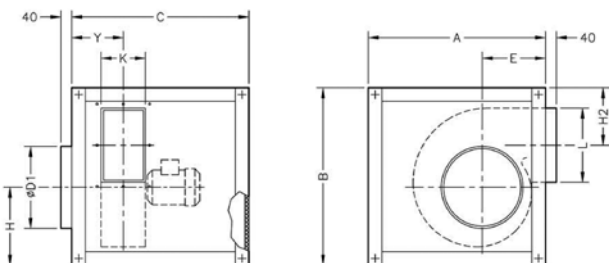

Model	A	B	C	ØD1	E	H	H2	K	L	Y
CJMP-922	720	720	720	224	187	349	237	140	215	176
CJMP-1025	800	800	800	250	204	379	277	165	250	178
CJMP-1128	880	880	880	280	223	409	319	180	295	191
CJMP-1231	970	970	970	315	245	459	332	200	320	205
CJMP-1435	1070	1070	1070	355	257	514	314	230	280	291
CJMP-1640	1160	1160	1160	400	277	564	325	250	320	325
CJMP-1845	865	1260	1050	450	309	629	326	284	360	357
CJMP-2050	965	1400	1200	500	352	679	408	315	450	383.5

## Characteristic curves

Q = Airflow in m<sup>3</sup>/h, m<sup>3</sup>/s and cfm.

Pe = Static pressure in mm.w.c., Pa and inwg.

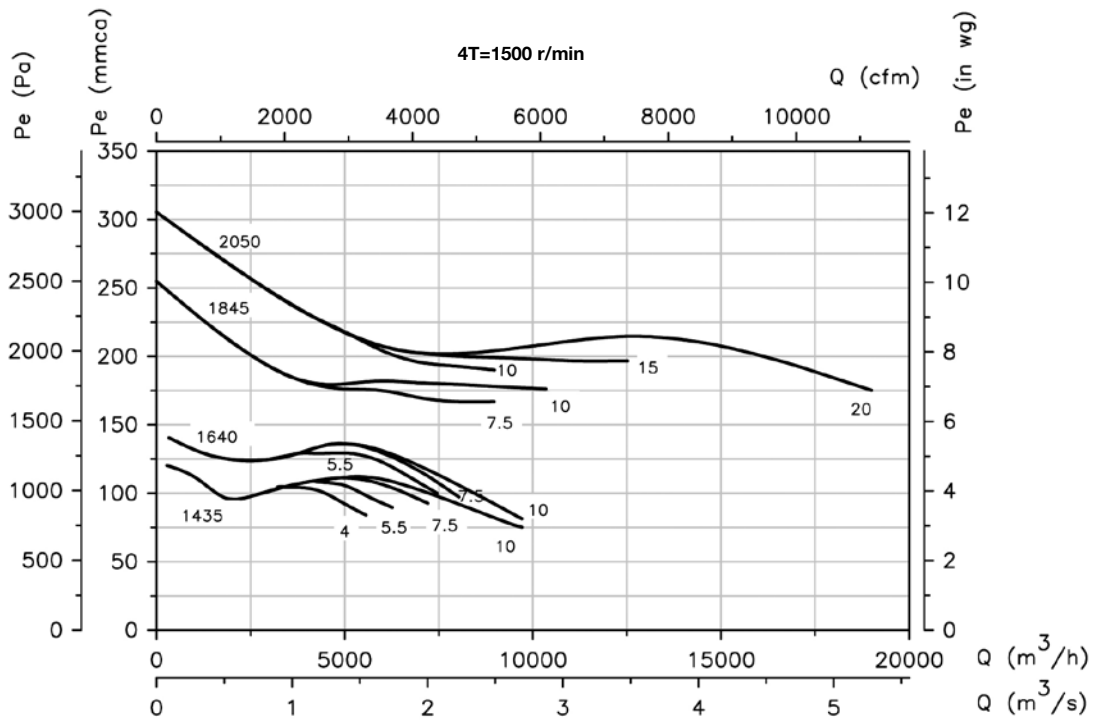
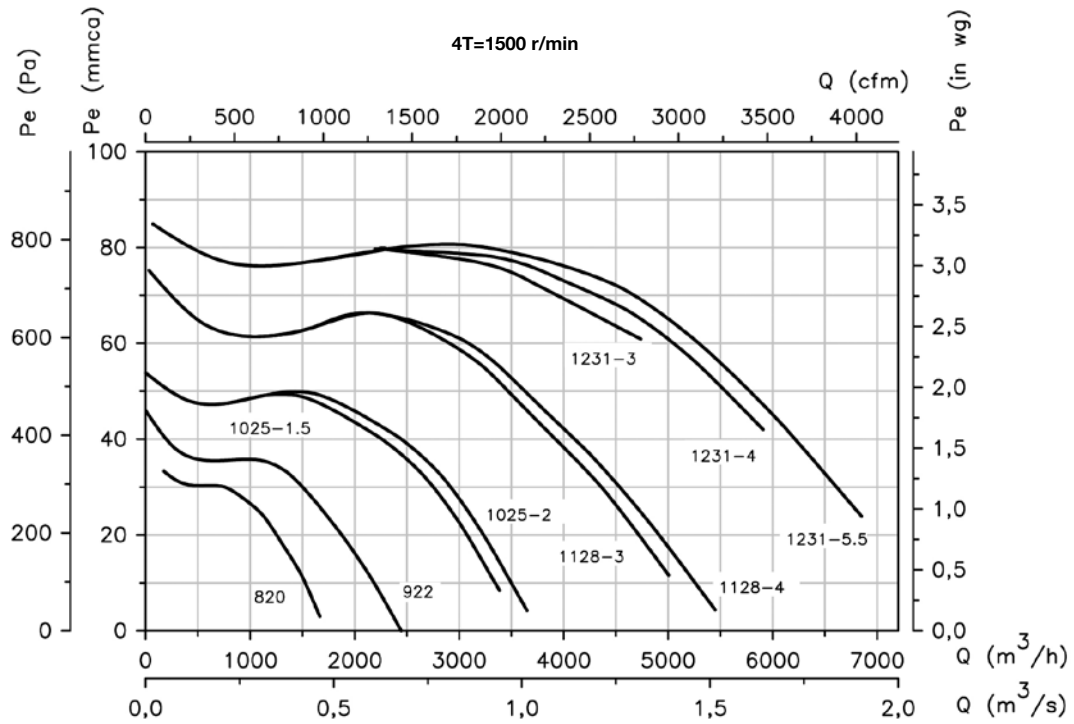

**Characteristic curves**

Q = Airflow in m<sup>3</sup>/h, m<sup>3</sup>/s and cfm.

Pe= Static pressure in mm.w.c., Pa and inwg.

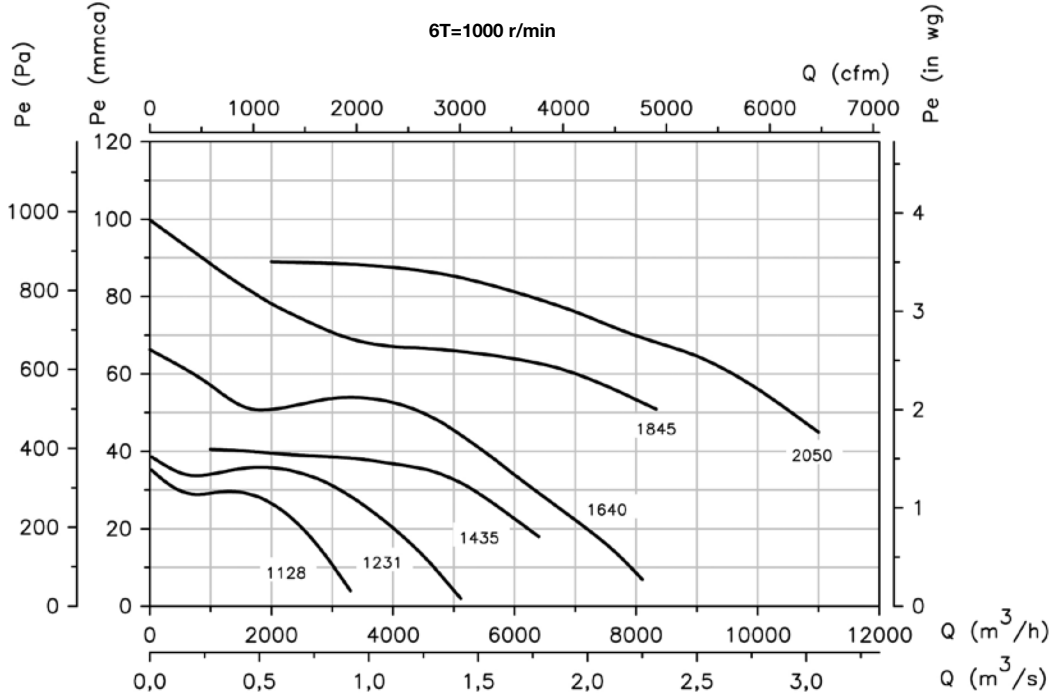

**Positions**

LG 270 standard supply

LG 180 and RD 180 positions on request and with special fixing measures.

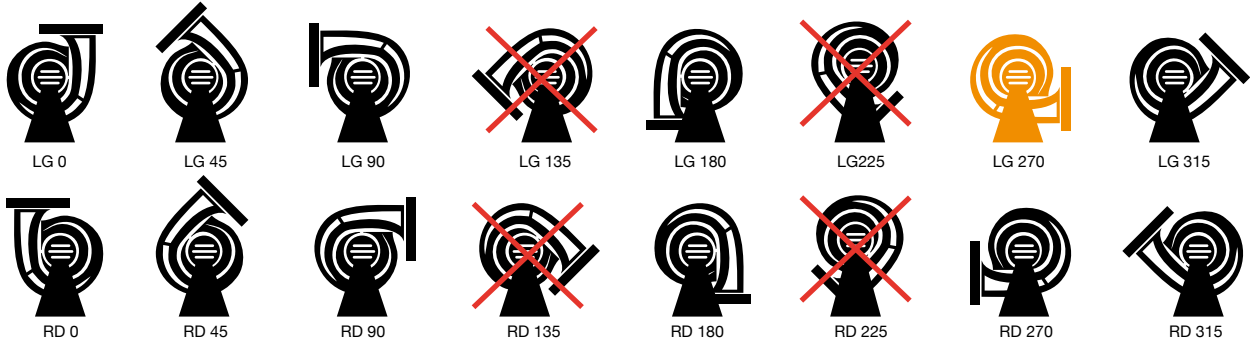

**Accessories**

See accessories section



# CJTX-C



## 400°C/2h belt-driven extraction units with double-inlet fan

400°C/2h extraction units with motor and belt-driven inside the plate to work outside fire danger zones.

### Fan:

- Galvanized sheet steel structure.
- Impeller with forward-facing blades made from galvanised sheet steel
- Approval according to Standard EN-12101-3-2002, certificate no.: 0370-CPD-0468
- Linear air circulation

### Motor:

- Class F motors with ball bearings, IP55 protection, one- or two-speed depending on the model
- Three-phase 230/400V.-50Hz. (up to 5.5CV) and 400/690V.-50Hz. (power over 5.5CV)
- Max. temperature of air for transport: S1 Service -20°C+ 120°C for ongoing use,

S2 Service 200°C/2h, 300°C/2h and 400°C/2h

### Finish:

- Anticorrosive galvanized sheet steel.

### On request:

- Fans with vertical outlet



## Order code

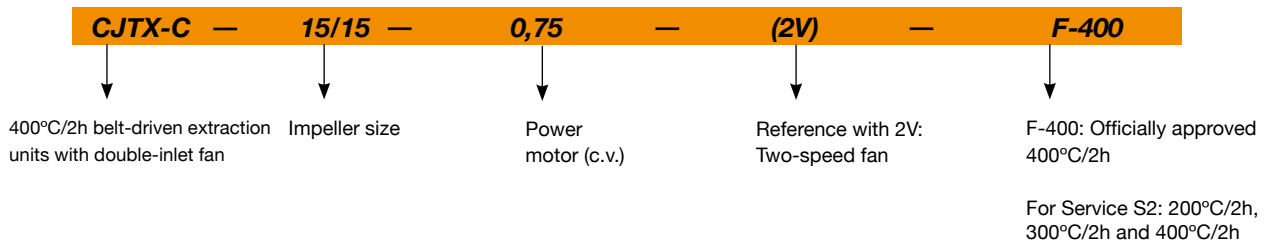

## Technical characteristics

Model	Speed (r/min)	Maximum admissible current (A)			Power installed (kW)	Airflow maximum (m³/h)	Sound pressure level dB(A)	Approx. weight (Kg)
		230V	400V (A)	690V				
CJTX-C-7/7-0,25	1000	1.03	0.59		0.18	1600	58	53
CJTX-C-7/7-0,33	1200	1.30	0.75		0.25	1825	60	54
CJTX-C-7/7-0,33 2V	1200 / 600		0.70 / 0.30		0.25/ 0.10	1825 / 915	60 / 45	54
CJTX-C-7/7-0,5	1400	1.85	1.06		0.37	2100	64	54
CJTX-C-7/7-0,5 2V	1400 / 700		1.05 / 0.50		0.37 / 0.11	2100 / 1050	64 / 49	57
CJTX-C-7/7-0,75	1600	2.59	1.49		0.55	2350	67	58
CJTX-C-7/7-0,75 2V	1600 / 800		1.70 / 0.80		0.55/ 0.19	2350 / 1175	67 / 52	58
CJTX-C-7/7-1	1800	2.96	1.71		0.75	2600	69	62
CJTX-C-7/7-1 2V	1800 / 900		2.00 / 0.90		0.75/ 0.20	2600 / 1300	69 / 54	61
CJTX-C-9/9-0,33	850	1.30	0.75		0.25	2300	58	65
CJTX-C-9/9-0,33 2V	850 / 425		0.70 / 0.30		0.25/ 0.10	2300 / 1150	58 / 43	65
CJTX-C-9/9-0,5	960	1.85	1.06		0.37	2800	61	66
CJTX-C-9/9-0,5 2V	960 / 480		1.05 / 0.50		0.37 / 0.11	2800 / 1400	61 / 46	67
CJTX-C-9/9-0,75	1060	2.59	1.49		0.55	3200	65	69
CJTX-C-9/9-0,75 2V	1060 / 530		1.70 / 0.80		0.55/ 0.19	3200 / 1600	65 / 50	69
CJTX-C-9/9-1	1200	2.96	1.71		0.75	3500	67	73
CJTX-C-9/9-1 2V	1200 / 600		2.00 / 0.90		0.75/ 0.20	3500 / 1750	67 / 52	72
CJTX-C-9/9-1,5	1340	4.38	2.53		1.10	4100	70	80
CJTX-C-9/9-1,5 2V	1340 / 670		2.90 / 1.30		1.10/ 0.25	4100 / 2050	70 / 55	74
CJTX-C-9/9-2	1500	5.53	3.19		1.50	4400	72	84
CJTX-C-9/9-2 2V	1500 / 750		3.50 / 1.50		1.50/ 0.37	4400 / 2200	72 / 57	76
CJTX-C-10/10-0,33	660	1.30	0.75		0.25	2800	57	77

## Technical characteristics

Model	Speed (r/min)	Maximum admissible current (A)			Power installed (kW)	Airflow maximum (m³/h)	Sound pressure level dB(A)	Approx. weight (Kg)
		230V	400V (A)	690V				
CJTX-C-10/10-0,33 2V	660 / 330		0.70 / 0.30		0.25/ 0.10	2800 / 1400	57 / 42	77
CJTX-C-10/10-0,5	800	1.85	1.06		0.37	3300	61	77
CJTX-C-10/10-0,5 2V	800 / 400		1.05 / 0.50		0.37/ 0.11	3300 / 1650	61 / 46	79
CJTX-C-10/10-0,75	880	2.59	1.49		0.55	3800	63	81
CJTX-C-10/10-0,75 2V	880 / 440		1.70 / 0.80		0.55/ 0.19	3800 / 1900	63 / 48	81
CJTX-C-10/10-1	1000	2.96	1.71		0.75	4200	65	85
CJTX-C-10/10-1 2V	1000 / 500		2.00 / 0.90		0.75/ 0.20	4200 / 2100	65 / 50	84
CJTX-C-10/10-1,5	1130	4.38	2.53		1.10	4800	68	92
CJTX-C-10/10-1,5 2V	1130 / 565		2.90 / 1.30		1.10/ 0.25	4800 / 2400	68 / 53	85
CJTX-C-10/10-2	1270	5.53	3.19		1.50	5300	71	94
CJTX-C-10/10-2 2V	1270 / 635		3.50 / 1.50		1.50/ 0.37	5300 / 2650	71 / 56	86
CJTX-C-10/10-3	1450	8.40	4.85		2.20	5900	74	89
CJTX-C-10/10-3 2V	1450 / 725		4.90 / 1.70		2.20/ 0.45	5900 / 2950	74 / 59	93
CJTX-C-12/12-0,5	600	1.85	1.06		0.37	4200	60	96
CJTX-C-12/12-0,5 2V	600 / 300		1.05 / 0.50		0.37/ 0.11	4200 / 2100	60 / 45	98
CJTX-C-12/12-0,75	700	2.59	1.49		0.55	4600	63	99
CJTX-C-12/12-0,75 2V	700 / 350		1.70 / 0.80		0.55/ 0.19	4600 / 2300	63 / 48	100
CJTX-C-12/12-1	800	2.96	1.71		0.75	5100	65	104
CJTX-C-12/12-1 2V	800 / 400		2.00 / 0.90		0.75/ 0.20	5100 / 2550	65 / 50	103
CJTX-C-12/12-1,5	880	4.38	2.53		1.10	5700	68	111
CJTX-C-12/12-1,5 2V	880 / 440		2.90 / 1.30		1.10/ 0.25	5700 / 2850	68 / 53	104
CJTX-C-12/12-2	1020	5.53	3.19		1.50	6400	70	113
CJTX-C-12/12-2 2V	1020 / 510		3.50 / 1.50		1.50/ 0.37	6400 / 3200	70 / 55	105
CJTX-C-12/12-3	1140	8.40	4.85		2.20	7400	73	107
CJTX-C-12/12-3 2V	1140 / 570		4.90 / 1.70		2.20/ 0.45	7400 / 3700	73 / 58	110
CJTX-C-12/12-4	1250	11.22	6.48		3.00	8200	75	115
CJTX-C-12/12-4 2V	1250 / 625		6.50 / 2.30		3.00/ 0.60	8200 / 4100	75 / 60	118
CJTX-C-15/15-0,75	530	2.59	1.49		0.55	4700	59	126
CJTX-C-15/15-0,75 2V	530 / 265		1.70 / 0.80		0.55/ 0.19	4700 / 2350	59 / 44	126
CJTX-C-15/15-1	560	2.96	1.71		0.75	6000	61	130
CJTX-C-15/15-1 2V	560 / 280		2.00 / 0.90		0.75/ 0.20	6000 / 3000	61 / 46	129
CJTX-C-15/15-1,5	630	4.38	2.53		1.10	7000	64	138
CJTX-C-15/15-1,5 2V	630 / 315		2.90 / 1.30		1.10/ 0.25	7000 / 3500	64 / 49	131
CJTX-C-15/15-2	700	5.53	3.19		1.50	7800	66	141
CJTX-C-15/15-2 2V	700 / 350		3.50 / 1.50		1.50/ 0.37	7800 / 3900	66 / 51	133
CJTX-C-15/15-3	800	8.40	4.85		2.20	9000	69	135
CJTX-C-15/15-3 2V	800 / 400		4.90 / 1.70		2.20/ 0.45	9000 / 4500	69 / 54	140
CJTX-C-15/15-4	880	11.22	6.48		3.00	10000	72	144
CJTX-C-15/15-4 2V	880 / 440		6.50 / 2.30		3.00/ 0.60	10000 / 5000	72 / 57	147
CJTX-C-15/15-5,5	970	14.98	8.65		4.00	11000	73	145
CJTX-C-15/15-5,5 2V	970 / 485		8.20 / 2.90		4.00/ 0.80	11000 / 5500	73 / 58	151
CJTX-C-18/18-1	460	2.96	1.71		0.75	7500	60	163
CJTX-C-18/18-1 2V	460 / 230		2.00 / 0.90		0.75/ 0.20	7500 / 3750	60 / 45	163
CJTX-C-18/18-1,5	510	4.38	2.53		1.10	9000	61	171
CJTX-C-18/18-1,5 2V	510 / 255		2.90 / 1.30		1.10/ 0.25	9000 / 4500	61 / 46	165
CJTX-C-18/18-2	540	5.53	3.19		1.50	10800	64	175
CJTX-C-18/18-2 2V	540 / 270		3.50 / 1.50		1.50/ 0.37	10800 / 5400	64 / 49	167
CJTX-C-18/18-3	610	8.40	4.85		2.20	12500	67	170
CJTX-C-18/18-3 2V	610 / 305		4.90 / 1.70		2.20/ 0.45	12500 / 6250	67 / 52	173
CJTX-C-18/18-4	680	11.22	6.48		3.00	14000	70	177
CJTX-C-18/18-4 2V	680 / 340		6.50 / 2.30		3.00/ 0.60	14000 / 7000	70 / 55	180
CJTX-C-18/18-5,5	750	14.98	8.65		4.00	15000	72	178
CJTX-C-18/18-5,5 2V	750 / 375		8.20 / 2.90		4.00/ 0.80	15000 / 7500	72 / 57	184
CJTX-C-18/18-7,5	850		11.40	6.60	5.50	16500	74	188
CJTX-C-18/18-7,5 2V	850 / 425		11.80 / 3.80		5.50/ 1.10	16500 / 8250	74 / 59	204
CJTX-C-18/18-10	930		14.80	8.50	7.50	18000	77	202
CJTX-C-18/18-10 2V	930 / 465		15.30 / 5.40		7.50/ 1.50	18000 / 9000	77 / 62	213
CJTX-C-20/20-2	450	5.53	3.19		1.50	13000	64	276
CJTX-C-20/20-2 2V	450 / 225		3.50 / 1.50		1.50/ 0.37	13000 / 6500	64 / 49	268
CJTX-C-20/20-3	530	8.40	4.85		2.20	15000	68	270
CJTX-C-20/20-3 2V	530 / 265		4.90 / 1.70		2.20/ 0.45	15000 / 7500	68 / 53	274
CJTX-C-20/20-4	580	11.22	6.48		3.00	16300	70	277
CJTX-C-20/20-4 2V	580 / 290		6.50 / 2.30		3.00/ 0.60	16300 / 8150	70 / 55	280
CJTX-C-20/20-5,5	660	14.98	8.65		4.00	18000	72	279

## Technical characteristics

Model	Speed (r/min)	Maximum admissible current (A)			Power installed (kW)	Airflow maximum (m³/h)	Sound pressure level dB(A)	Approx. weight (Kg)
		230V	400V (A)	690V				
CJTX-C-20/20-5,5 2V	660 / 330		8.20 / 2.90		4.00 / 0.80	18000 / 9000	72 / 57	285
CJTX-C-20/20-7,5	740		11.40	6.60	5.50	20500	74	289
CJTX-C-20/20-7,5 2V	740 / 370		11.80 / 3.80		5.50 / 1.10	20500 / 10250	74 / 59	305
CJTX-C-20/20-10	815		14.80	8.50	7.50	22500	77	304
CJTX-C-20/20-10 2V	815 / 408		15.30 / 5.40		7.50 / 1.50	22500 / 11250	77 / 62	314
CJTX-C-22/22-2	380	5.53	3.19		1.50	14000	62	318
CJTX-C-22/22-2 2V	380 / 190		3.50 / 1.50		1.50 / 0.37	14000 / 7000	62 / 47	310
CJTX-C-22/22-3	430	8.40	4.85		2.20	16000	64	312
CJTX-C-22/22-3 2V	430 / 215		4.90 / 1.70		2.20 / 0.45	16000 / 8000	64 / 49	316
CJTX-C-22/22-4	480	11.22	6.48		3.00	18000	68	320
CJTX-C-22/22-4 2V	480 / 240		6.50 / 2.30		3.00 / 0.60	18000 / 9000	68 / 53	323
CJTX-C-22/22-5,5	520	14.98	8.65		4.00	20000	69	323
CJTX-C-22/22-5,5 2V	520 / 260		8.20 / 2.90		4.00 / 0.80	20000 / 10000	69 / 54	329
CJTX-C-22/22-7,5	580		11.40	6.60	5.50	22500	72	333
CJTX-C-22/22-7,5 2V	580 / 290		11.80 / 3.80		5.50 / 1.10	22500 / 11250	72 / 57	350
CJTX-C-22/22-10	650		14.80	8.50	7.50	25000	74	346
CJTX-C-22/22-10 2V	650 / 325		15.30 / 5.40		7.50 / 1.50	25000 / 12500	74 / 59	357
CJTX-C-22/22-15	740		21.00	12.10	11.00	28000	77	358
CJTX-C-22/22-15 2V	740 / 370		23.20 / 8.70		10.50 / 2.80	28000 / 14000	77 / 62	389
CJTX-C-22/22-20	780		28.60	16.50	15.00	31000	79	424
CJTX-C-22/22-20 2V	780 / 390		31.72 / 11.75		15.00 / 3.80	31000 / 15500	79 / 64	413
CJTX-C-25/25-3	340	8.40	4.85		2.20	20000	66	369
CJTX-C-25/25-3 2V	340 / 170		4.90 / 1.70		2.20 / 0.45	20000 / 10000	66 / 51	372
CJTX-C-25/25-4	380	11.22	6.48		3.00	22000	68	376
CJTX-C-25/25-4 2V	380 / 190		6.50 / 2.30		3.00 / 0.60	22000 / 11000	68 / 53	379
CJTX-C-25/25-5,5	420	14.98	8.65		4.00	24000	70	377
CJTX-C-25/25-5,5 2V	420 / 210		8.20 / 2.90		4.00 / 0.80	24000 / 12000	70 / 55	383
CJTX-C-25/25-7,5	470		11.40	6.60	5.50	26500	73	393
CJTX-C-25/25-7,5 2V	470 / 235		11.80 / 3.80		5.50 / 1.10	26500 / 13250	73 / 58	409
CJTX-C-25/25-10	510		14.80	8.50	7.50	29000	75	401
CJTX-C-25/25-10 2V	510 / 255		15.30 / 5.40		7.50 / 1.50	29000 / 14500	75 / 60	412
CJTX-C-25/25-15	570		21.00	12.10	11.00	34000	78	419
CJTX-C-25/25-15 2V	570 / 285		23.20 / 8.70		10.50 / 2.80	34000 / 17000	78 / 63	450
CJTX-C-25/25-20	630		28.60	16.50	15.00	38000	80	482
CJTX-C-25/25-20 2V	630 / 315		31.72 / 11.75		15.00 / 3.80	38000 / 19000	80 / 65	471
CJTX-C-30/28-3	250	8.40	4.85		2.20	25000	64	502
CJTX-C-30/28-3 2V	250 / 125		4.90 / 1.70		2.20 / 0.45	25000 / 12500	64 / 49	507
CJTX-C-30/28-4	280	11.22	6.48		3.00	27000	66	516
CJTX-C-30/28-4 2V	280 / 140		6.50 / 2.30		3.00 / 0.60	27000 / 13500	66 / 51	519
CJTX-C-30/28-5,5	340	14.98	8.65		4.00	29000	68	517
CJTX-C-30/28-5,5 2V	340 / 170		8.20 / 2.90		4.00 / 0.80	29000 / 14500	68 / 53	523
CJTX-C-30/28-7,5	360		11.40	6.60	5.50	32500	71	530
CJTX-C-30/28-7,5 2V	360 / 180		11.80 / 3.80		5.50 / 1.10	32500 / 16250	71 / 56	546
CJTX-C-30/28-10	410		14.80	8.50	7.50	36000	73	545
CJTX-C-30/28-10 2V	410 / 205		15.30 / 5.40		7.50 / 1.50	36000 / 18000	73 / 58	556
CJTX-C-30/28-15	480		21.00	12.10	11.00	40000	76	557
CJTX-C-30/28-15 2V	480 / 240		23.20 / 8.70		10.50 / 2.80	40000 / 20000	76 / 61	588
CJTX-C-30/28-20	520		28.60	16.50	15.00	45000	78	627
CJTX-C-30/28-20 2V	520 / 260		31.72 / 11.75		15.00 / 3.80	45000 / 22500	78 / 63	616
CJTX-C-30/28-25	550		36.00	20.80	18.50	49000	79	609
CJTX-C-30/28-25 2V	550 / 275		33.00 / 11.00		17.00 / 3.40	49000 / 24500	79 / 64	643

## Dimensions in mm

### Standard supply horizontal outlet (H): LG-90

VIEWED FROM THE TOP

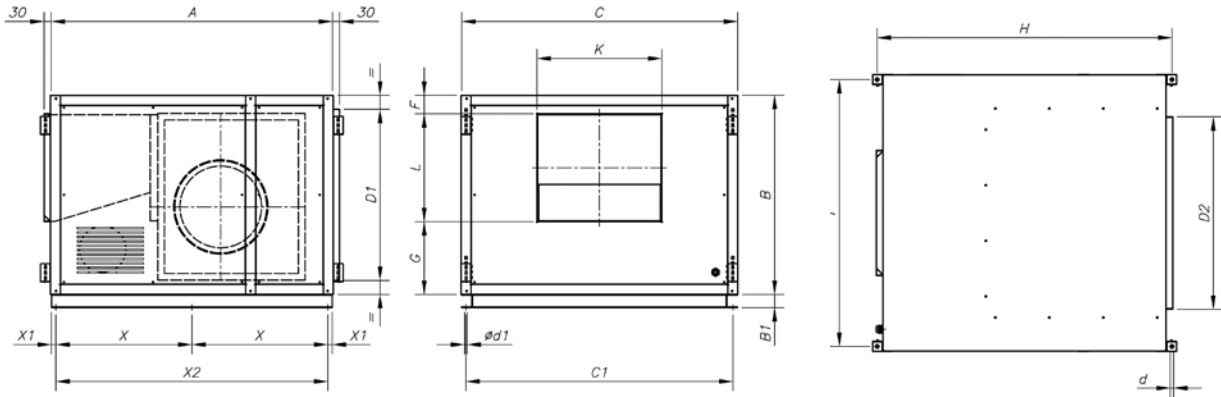

	A	B	B1	C	C1	Ød	Ød1	D1	D2	F	G	H	I	K	L	X	X1	X2
CJTX-C-7/7	700	480	-	730	695	10,5	9	354	470	62	202	750	685	239	216	-	-	-
CJTX-C-9/9	785	592	-	759	716	10,5	9	466	490	92	230	835	714	305	270	-	-	-
CJTX-C-10/10	860	618	-	825	782	10,5	9	492	520	87	235	910	780	334	296	-	-	-
CJTX-C-12/12	970	680	-	945	902	10,5	9	554	620	80	250	1020	900	395	350	-	-	-
CJTX-C-15/15	1100	776	-	1100	1057	10,5	9	650	720	80	285	1150	1055	483	411	-	-	-
CJTX-C-18/18	1278	900	60	1250	1207	10,5	11	774	870	95	325	1328	1205	552	480	614,5	20	1229
CJTX-C-20/20	1495	1050	60	1474	1431	13	11	954	1100	122	347	1555	1419	611	611	722,5	20	1545
CJTX-C-22/22	1640	1180	60	1625	1582	13	11	1054	1250	125	350	1700	1570	665	705	795,5	20	1591
CJTX-C-25/25	1800	1300	60	1825	1782	13	11	1174	1450	125	369	1860	1770	775	806	875,5	20	1751
CJTX-C-30/28	2000	1525	60	2134	2091	13	11	1399	1760	118	465	2060	2079	900	942	975,5	20	1951

### Supplied on request: Vertical outlet (V) LG-0

VIEWED FROM THE TOP

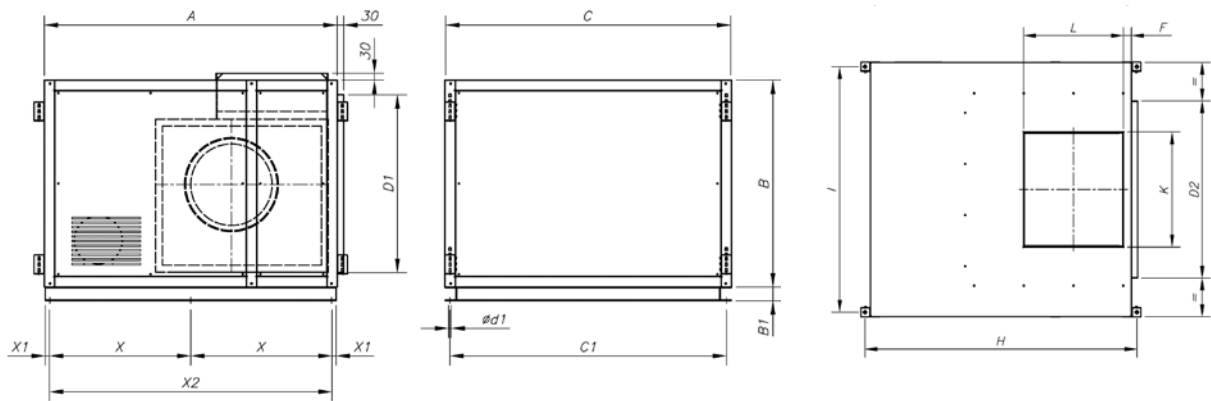

	A	B	B1	C	C1	Ød	Ød1	D1	D2	F	H	I	K	L	X	X1	X2
CJTX-C-7/7	700	480	-	730	695	10,5	9	354	470	66	750	685	239	216	-	-	-
CJTX-C-9/9	785	592	-	759	716	10,5	9	466	490	89	835	714	305	270	-	-	-
CJTX-C-10/10	860	618	-	825	782	10,5	9	492	520	86,5	910	780	334	296	-	-	-
CJTX-C-12/12	970	680	-	945	902	10,5	9	554	620	81,5	1020	900	395	350	-	-	-
CJTX-C-15/15	1100	776	-	1100	1057	10,5	9	650	720	83,5	1150	1055	483	411	-	-	-
CJTX-C-18/18	1278	900	60	1250	1207	10,5	11	774	870	83,5	1328	1205	552	480	614,5	20	1229
CJTX-C-20/20	1495	1050	60	1474	1431	13	11	954	1100	66	1555	1419	611	611	722,5	20	1545
CJTX-C-22/22	1640	1180	60	1625	1582	13	11	1054	1250	125,5	1700	1570	665	705	795,5	20	1591
CJTX-C-25/25	1800	1300	60	1825	1782	13	11	1174	1450	121	1860	1770	775	806	875,5	20	1751
CJTX-C-30/28	2000	1525	60	2134	2091	13	11	1399	1760	115,5	2060	2079	900	942	975,5	20	1951

## Characteristic curves

Q = Airflow in m<sup>3</sup>/h, m<sup>3</sup>/s and cfm.

Pe = Static pressure in mm.w.c., Pa and inwg.

### CJTX-C-7/7

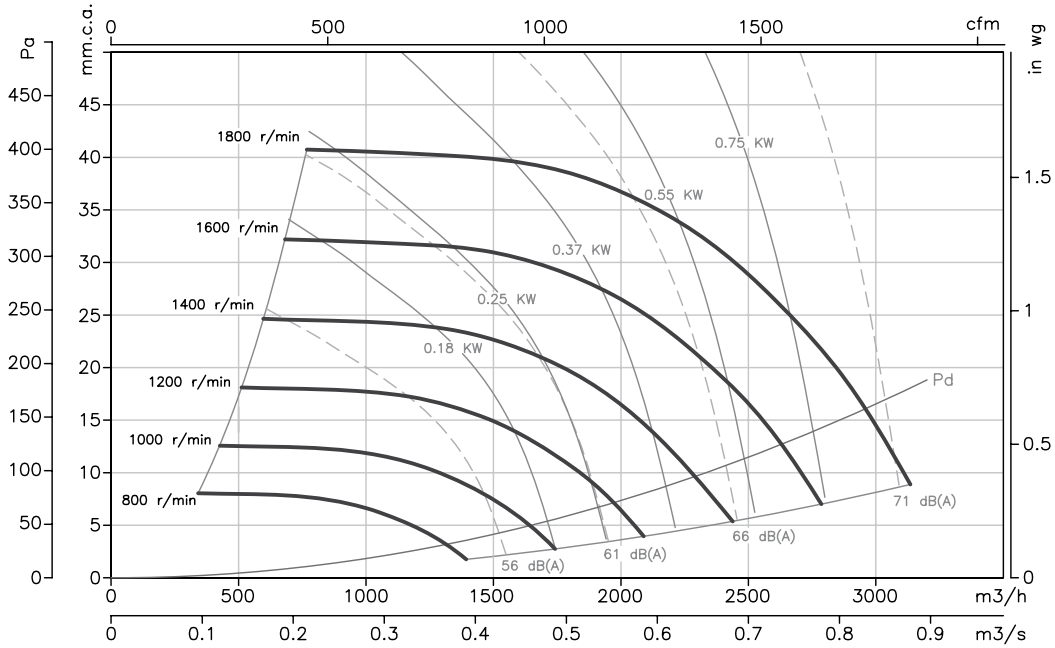

### CJTX-C-9/9

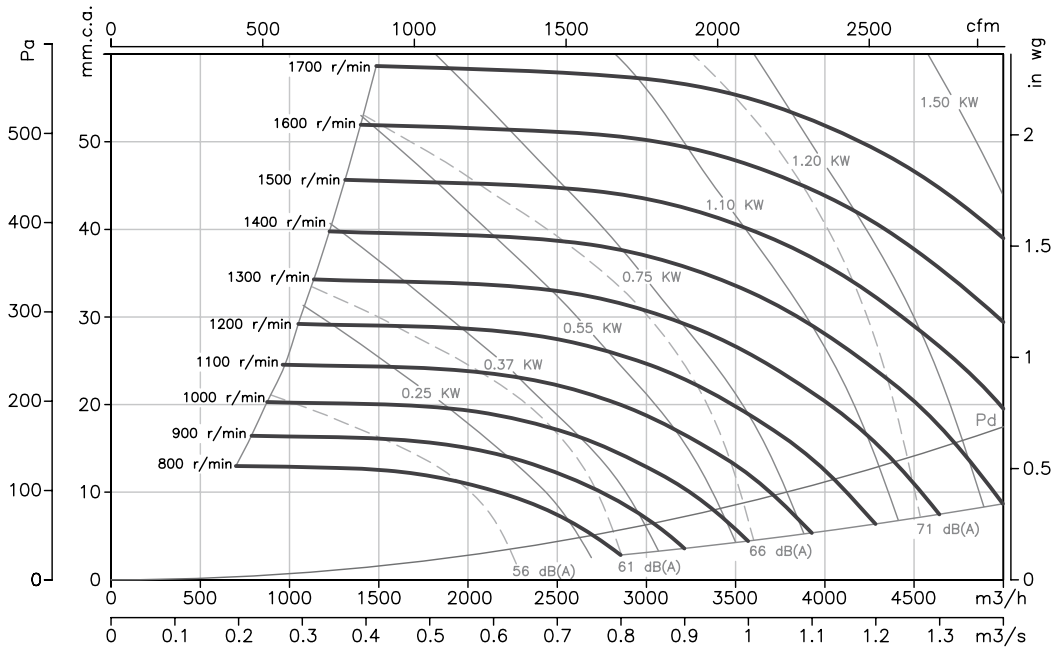

**Characteristic curves**

Q = Airflow in m<sup>3</sup>/h, m<sup>3</sup>/s and cfm.

Pe= Static pressure in mm.w.c., Pa and inwg.

**CJTX-C-10/10**

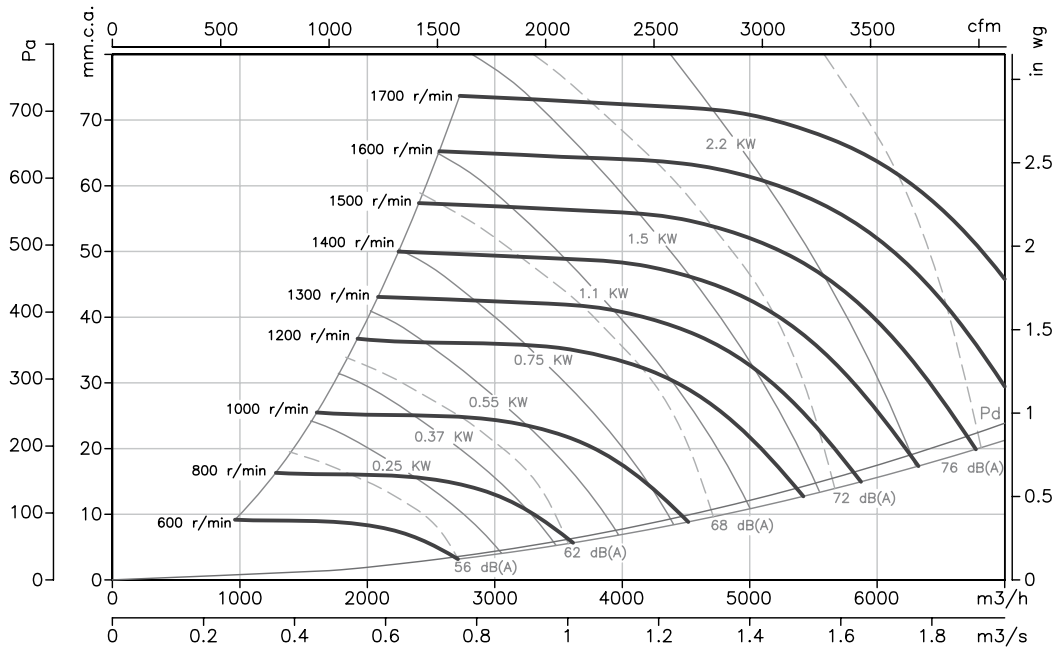

**CJTX-C-12/12**

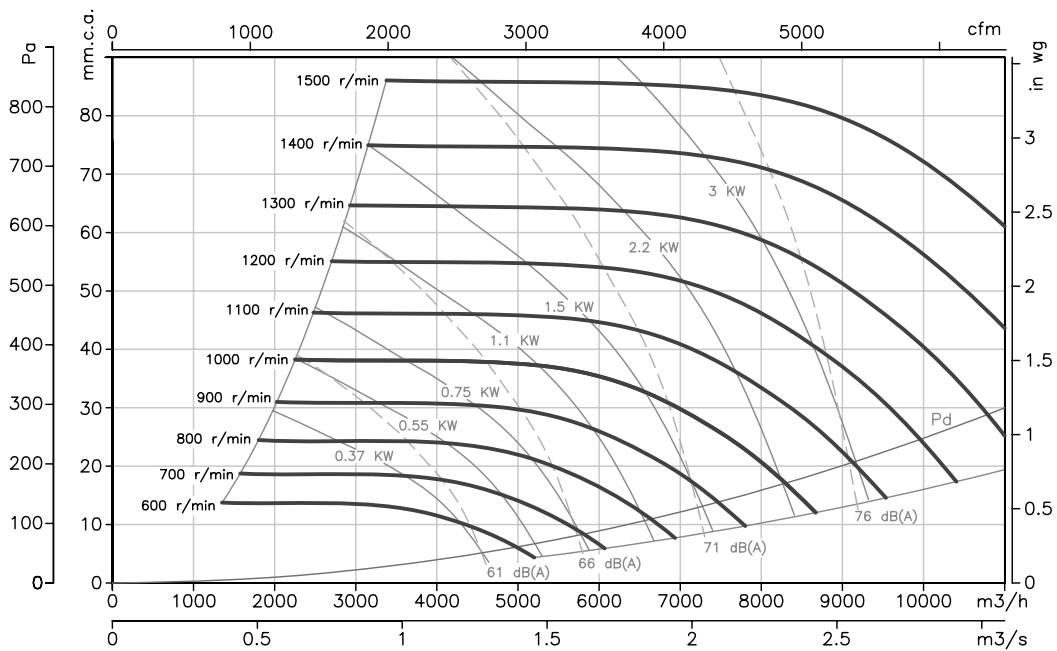

## Characteristic curves

Q = Airflow in m<sup>3</sup>/h, m<sup>3</sup>/s and cfm.

Pe = Static pressure in mm.w.c., Pa and inwg.

### CJTX-C-15/15

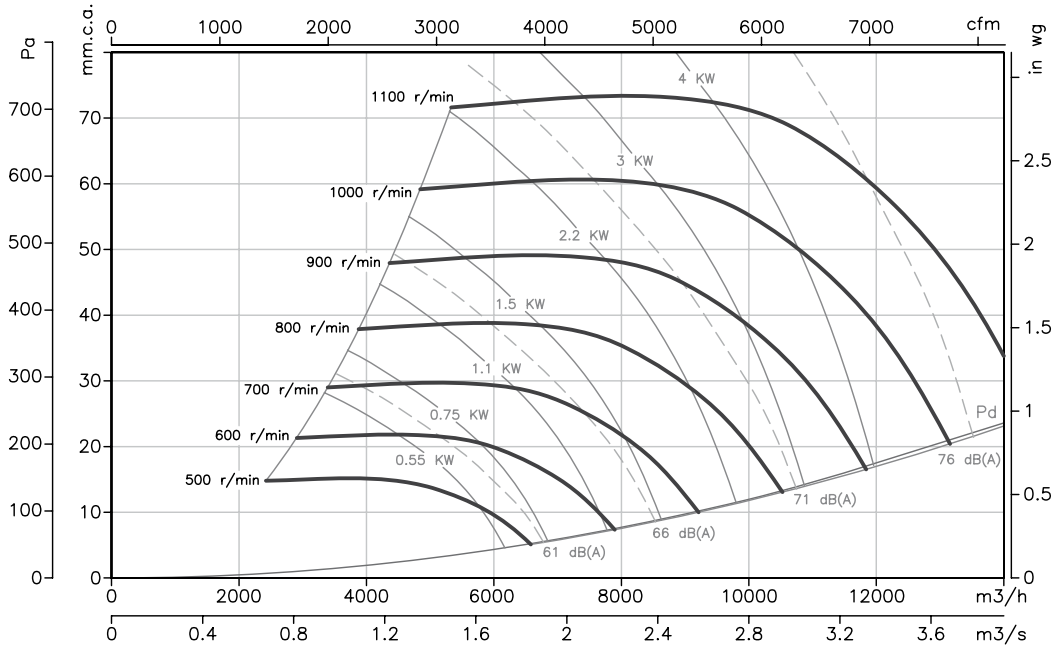

### CJTX-C-18/18

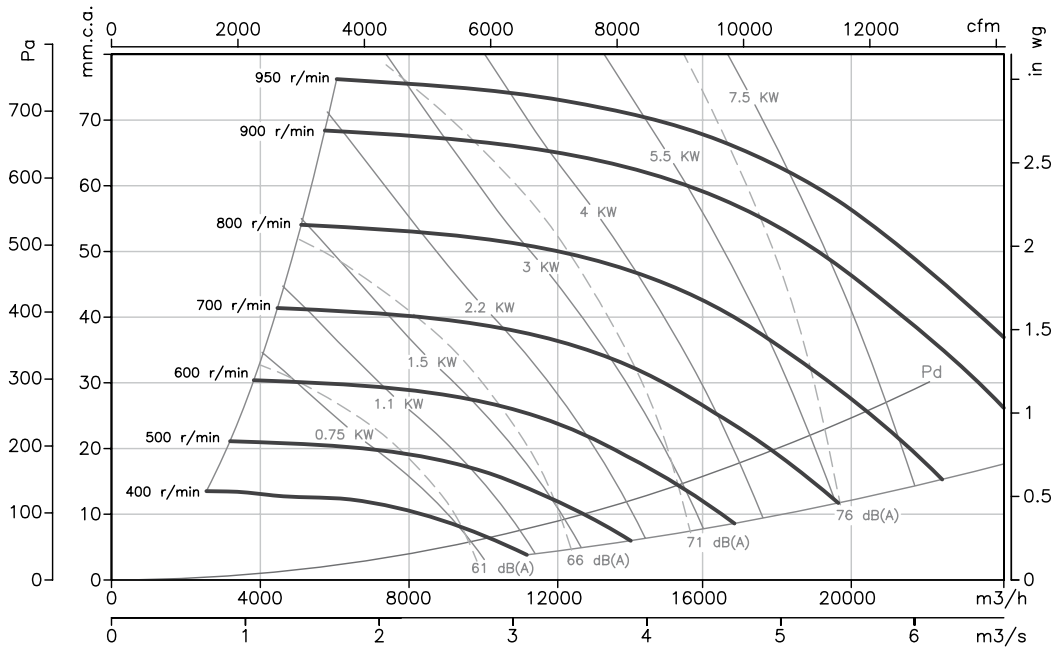

**Characteristic curves**

Q = Airflow in m<sup>3</sup>/h, m<sup>3</sup>/s and cfm.

Pe= Static pressure in mm.w.c., Pa and inwg.

**CJTX-C-20/20**

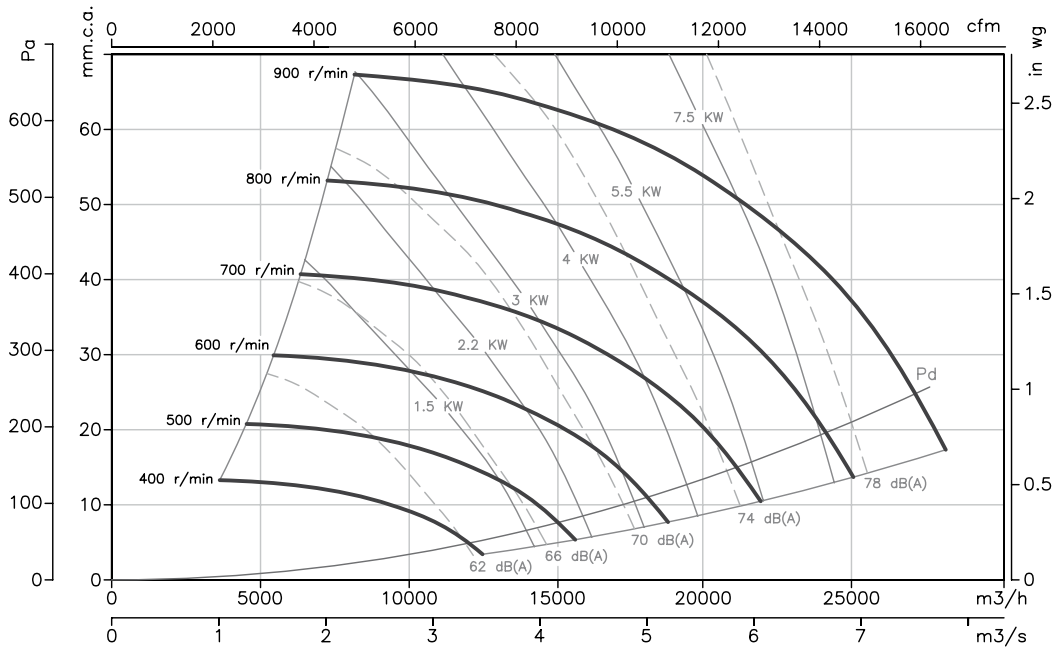

**CJTX-C-22/22**

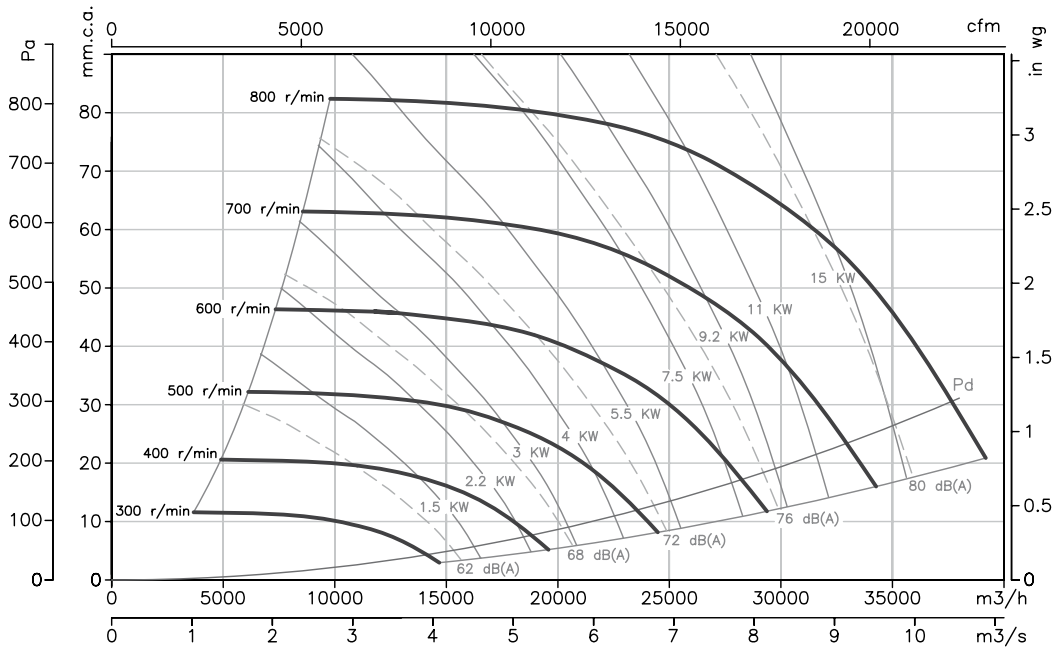

## Characteristic curves

Q = Airflow in m<sup>3</sup>/h, m<sup>3</sup>/s and cfm.

Pe = Static pressure in mm.w.c., Pa and inwg.

### CJTX-C-25/25

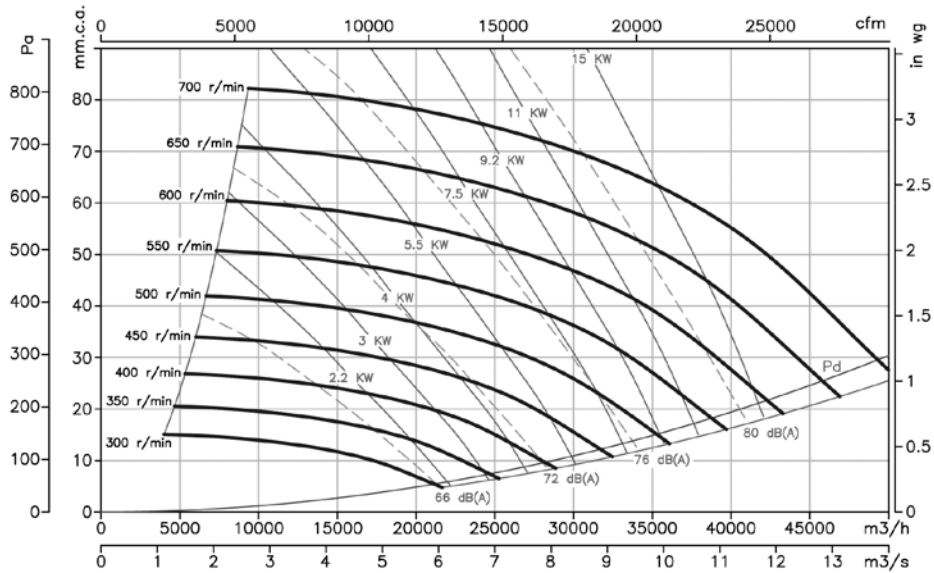

### CJTX-C-30/28

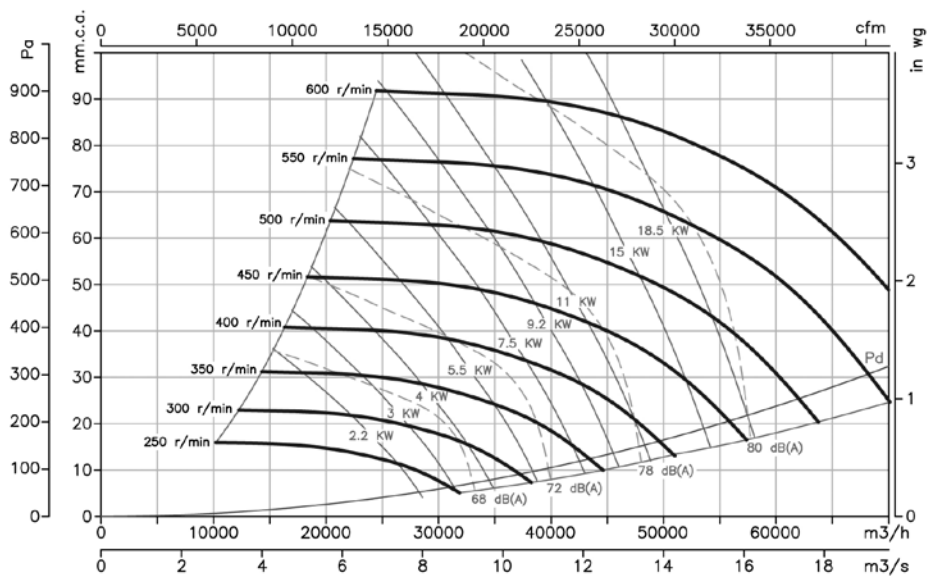

## Accessories

See accessories section



# CJSX



Motor outside the airflow path

## 400°C/2h belt-driven extraction units with single-inlet fan

400°C/2h extraction units with motor outside the airflow path to work outside fire danger zones.

### Fan:

- Galvanized sheet steel structure.
- Impeller with forward-facing blades made from galvanised sheet steel
- Approval according to Standard EN-12101-3-2002, certificate no.: 0370-CPD-0503

### Motor:

- Class F motors with ball bearings, IP55 protection
- Three-phase 230/400V.-50Hz. (up to 5.5CV.) and 400/690V.-50Hz. (power over 5.5CV.)
- Max. temperature of air for transport: S1 Service -20°C+ 120°C for ongoing use, S2 Service 200°C/2h, 300°C/2h and 400°C/2h

### Finish:

- Anticorrosive galvanized sheet steel.

### On request:

- Fans with two-speed motor.
- Fans with vertical outlet



## Order code

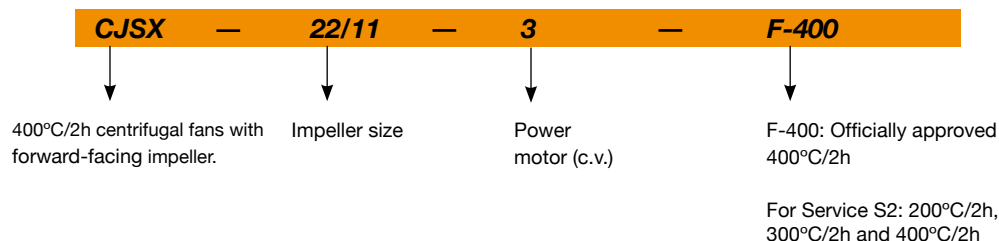

## Technical characteristics

Model	Speed (r/min)	Maximum admissible current (A)			Power installed (kW)	Airflow maximum (m³/h)	Sound pressure level dB(A)	Approx. weight (Kg)
		230V	400V (A)	690V				
CJSX-12/6-0,75	1000	2.42	1.40		0.55	2600	69	73
CJSX-12/6-1	1100	3.29	1.90		0.75	3100	71	74
CJSX-12/6-1,5	1250	4.49	2.59		1.10	3500	74	77
CJSX-12/6-2	1300	5.98	3.45		1.50	4250	77	80
CJSX-12/6-3	1500	8.31	4.80		2.20	4800	79	85
CJSX-15/7-1	800	3.29	1.90		0.75	4000	67	92
CJSX-15/7-1,5	850	4.49	2.59		1.10	4800	69	95
CJSX-15/7-2	920	5.98	3.45		1.50	5400	72	98
CJSX-15/7-3	1000	8.31	4.80		2.20	6400	75	103
CJSX-15/7-4	1050	11.22	6.48		3.00	7400	77	106
CJSX-18/9-1,5	750	4.49	2.59		1.10	5800	68	111
CJSX-18/9-2	790	5.98	3.45		1.50	6600	70	114
CJSX-18/9-3	800	8.31	4.80		2.20	8200	74	119
CJSX-18/9-4	850	11.22	6.48		3.00	9000	76	122
CJSX-18/9-5,5	920	14.90	8.60		4.00	10500	78	125
CJSX-20/10-2	650	5.98	3.45		1.50	8100	65	203
CJSX-20/10-3	690	8.31	4.80		2.20	10100	68	208
CJSX-20/10-4	750	11.22	6.48		3.00	11500	70	211
CJSX-20/10-5,5	790	14.90	8.60		4.00	13100	73	214

## Technical characteristics

Model	Speed (r/min)	Maximum admissible current (A)			Power installed (kW)	Airflow maximum (m³/h)	Sound pressure level dB(A)	Approx. weight (Kg)
		230V	400V (A)	690V				
CJSX-20/10-7,5	850		11.10	6.40	5.50	15000	75	227
CJSX-22/11-3	580	8.31	4.80		2.20	11200	67	219
CJSX-22/11-4	610	11.22	6.48		3.00	13000	70	222
CJSX-22/11-5,5	650	14.90	8.60		4.00	15000	72	225
CJSX-22/11-7,5	690		11.10	6.40	5.50	17000	74	238
CJSX-22/11-10	750		14.80	8.50	7.50	19000	76	246
CJSX-22/11-12,5	790		17.80	10.30	9.20	21000	78	257
CJSX-22/11-15	830		21.50	12.40	11.00	22000	79	273
CJSX-22/11-20	910		28.50	16.50	15.00	24500	81	292
CJSX-22/11-25	1000		35.00	20.20	18.50	26000	83	322
CJSX-25/13-4	520	11.22	6.48		3.00	14000	62	254
CJSX-25/13-5,5	550	14.90	8.60		4.00	17000	65	257
CJSX-25/13-7,5	590		11.10	6.40	5.50	19500	67	270
CJSX-25/13-10	620		14.80	8.50	7.50	23000	70	278
CJSX-25/13-12,5	650		17.80	10.30	9.20	25000	72	289
CJSX-25/13-15	690		21.50	12.40	11.00	26500	74	305
CJSX-25/13-20	750		28.50	16.50	15.00	29500	75	324
CJSX-25/13-25	810		35.00	20.20	18.50	32000	77	354
CJSX-30/14-5,5	400	14.90	8.60		4.00	21000	69	331
CJSX-30/14-7,5	425		11.10	6.40	5.50	24000	72	344
CJSX-30/14-10	460		14.80	8.50	7.50	27500	74	352
CJSX-30/14-12,5	480		17.80	10.30	9.20	30000	76	363
CJSX-30/14-15	500		21.50	12.40	11.00	33000	77	379
CJSX-30/14-20	550		28.50	16.50	15.00	36500	78	398
CJSX-30/14-25	600		35.00	20.20	18.50	38000	81	428

## Dimensions in mm

Standard supply horizontal outlet (H) RD-90

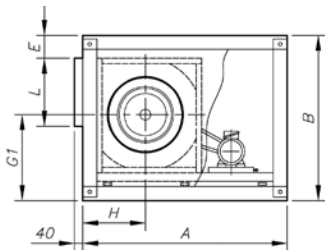

Supply on demand vertical outlet (V) RD-90

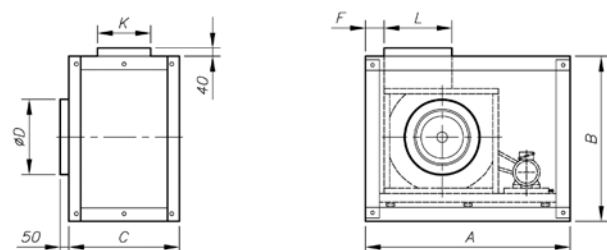

Supply on demand horizontal outlet (H) LG-90

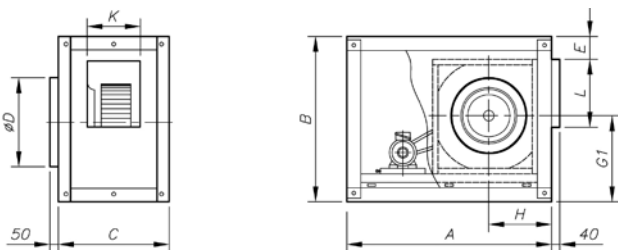

Supply on demand vertical outlet (V) LG-90

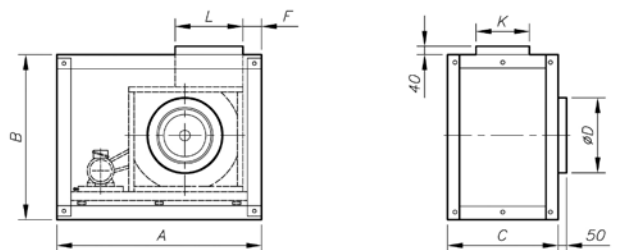

Modelo	A	B	C	ØD	E	com bank E	F	G1	com bank G1	H	L	com bank L	K
CJSX-12/6-H	850	650	540	330	74	-	-	288	-	288	346	-	210
CJSX-12/6-V	850	650	540	330	-	-	30	318	-	328	346	-	210
CJSX-15/7-H	1000	755	600	400	74	-	-	328	-	328	411	-	270
CJSX-15/7-V	1000	755	600	400	-	-	30	378	-	383	411	-	270
CJSX-18/9-H	1200	875	620	480	74	-	-	383	-	388	491	-	305
CJSX-18/9-V	1200	875	620	480	-	-	30	433	-	448	491	-	305
CJSX-20/10-H	1485	1175	730	565	175	120	-	475	530	440	613	605	343
CJSX-20/10-V	1485	1175	730	565	-	-	75	535	-	585	613	-	343
CJSX-22/11-H	1570	1250	760	615	165	110	-	510	565	470	708	700	373
CJSX-22/11-V	1570	1250	760	615	-	-	75	570	-	640	708	-	373
CJSX-25/13-H	1610	1375	820	685	175	120	-	550	605	495	803	795	423
CJSX-25/13-V	1610	1375	820	685	-	-	75	625	-	705	803	-	423
CJSX-30/14-H	1845	1600	855	820	160	95	-	655	710	580	943	935	488
CJSX-30/14-V	1845	1600	855	820	-	-	75	760	-	825	943	-	488

**Characteristic curves**

Q = Airflow in m<sup>3</sup>/h, m<sup>3</sup>/s and cfm.

Pe= Static pressure in mm.w.c., Pa and inwg.

**CJSX 12/6**

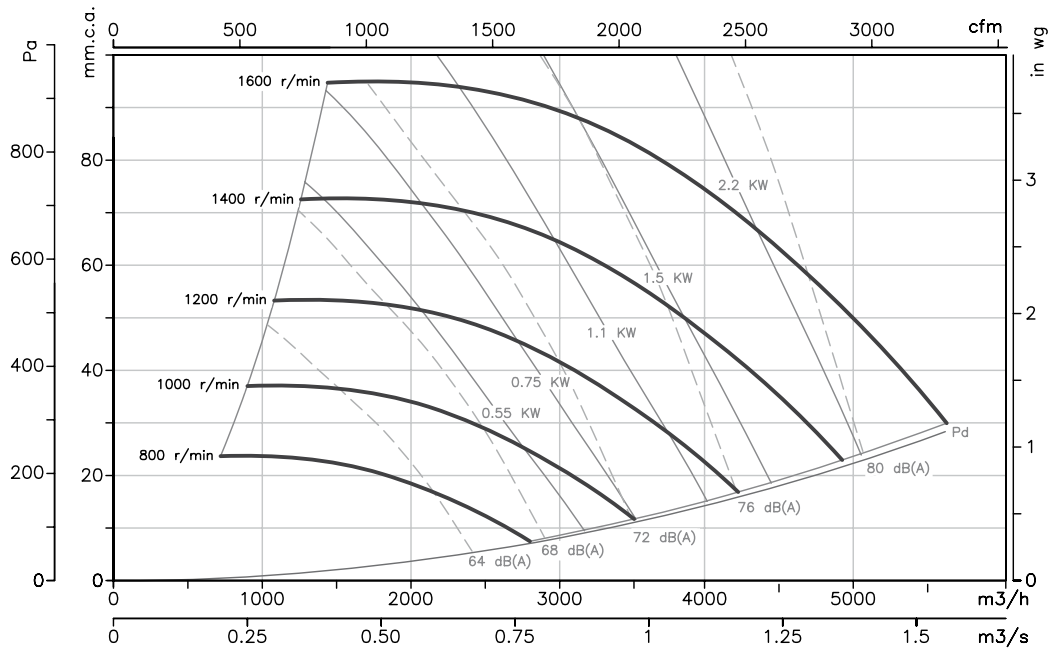

**CJSX 15/7**

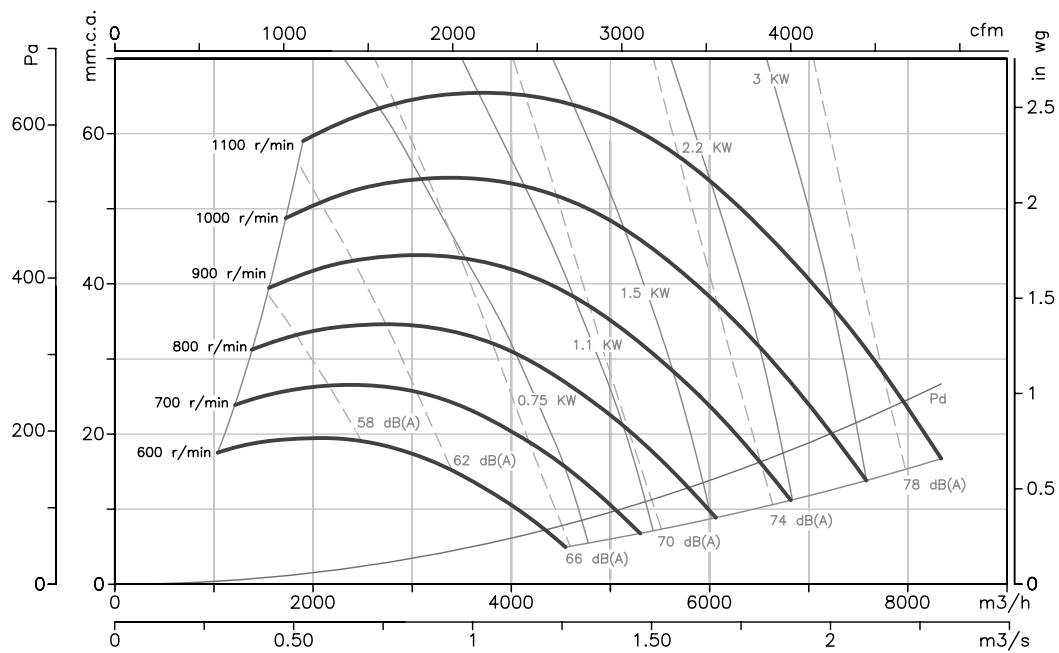

**Characteristic curves**

Q = Airflow in m<sup>3</sup>/h, m<sup>3</sup>/s and cfm.

Pe= Static pressure in mm.w.c., Pa and inwg.

**CJSX 18/9**

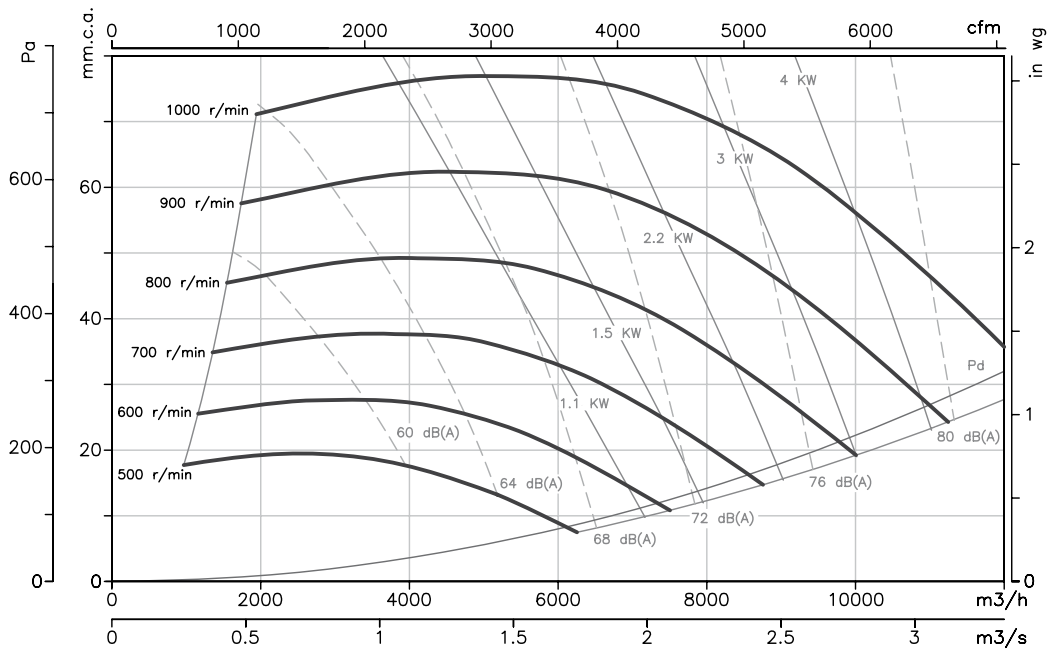

**CJSX 20/10**

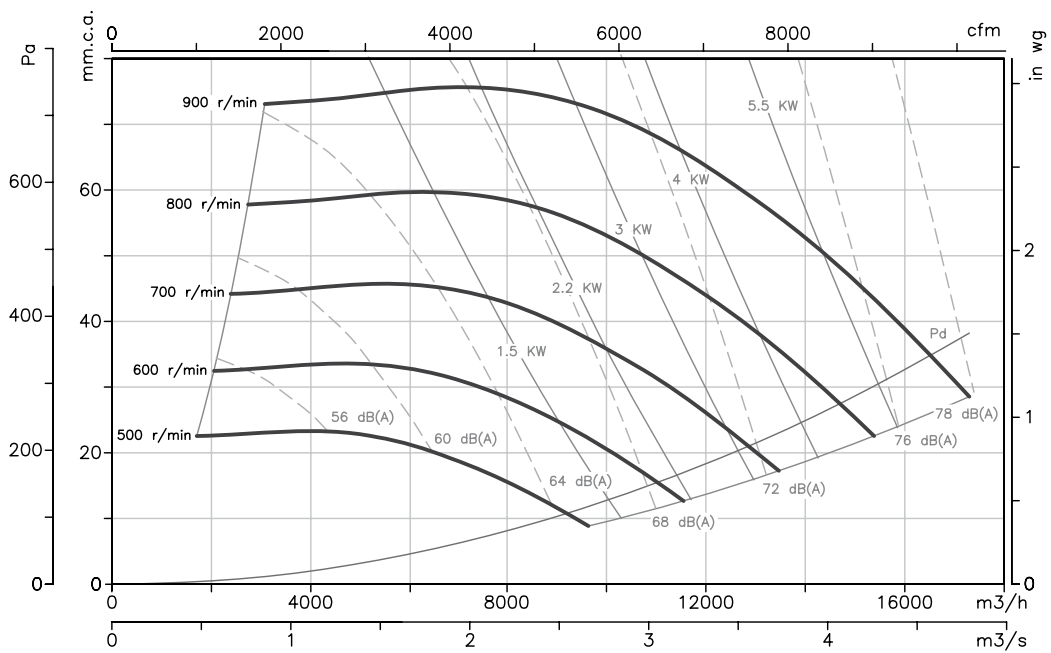

**Characteristic curves**

Q = Airflow in m<sup>3</sup>/h, m<sup>3</sup>/s and cfm.

Pe = Static pressure in mm.w.c., Pa and inwg.

**CJSX 22/11**

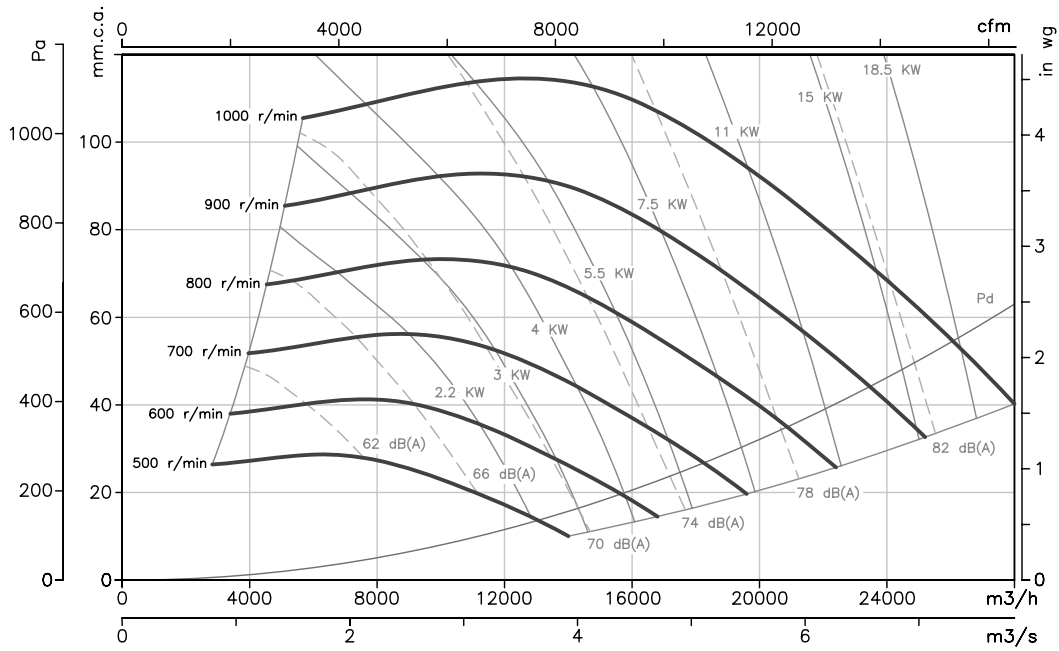

**CJSX 25/13**

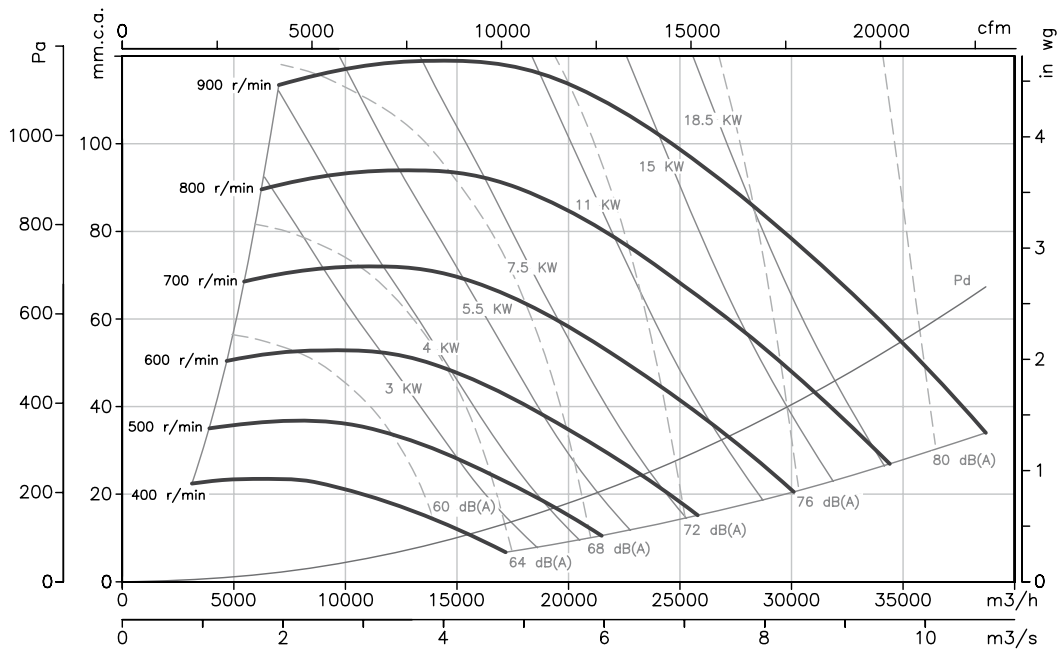

**Characteristic curves**

Q = Airflow in m<sup>3</sup>/h, m<sup>3</sup>/s and cfm.

Pe= Static pressure in mm.w.c., Pa and inwg.

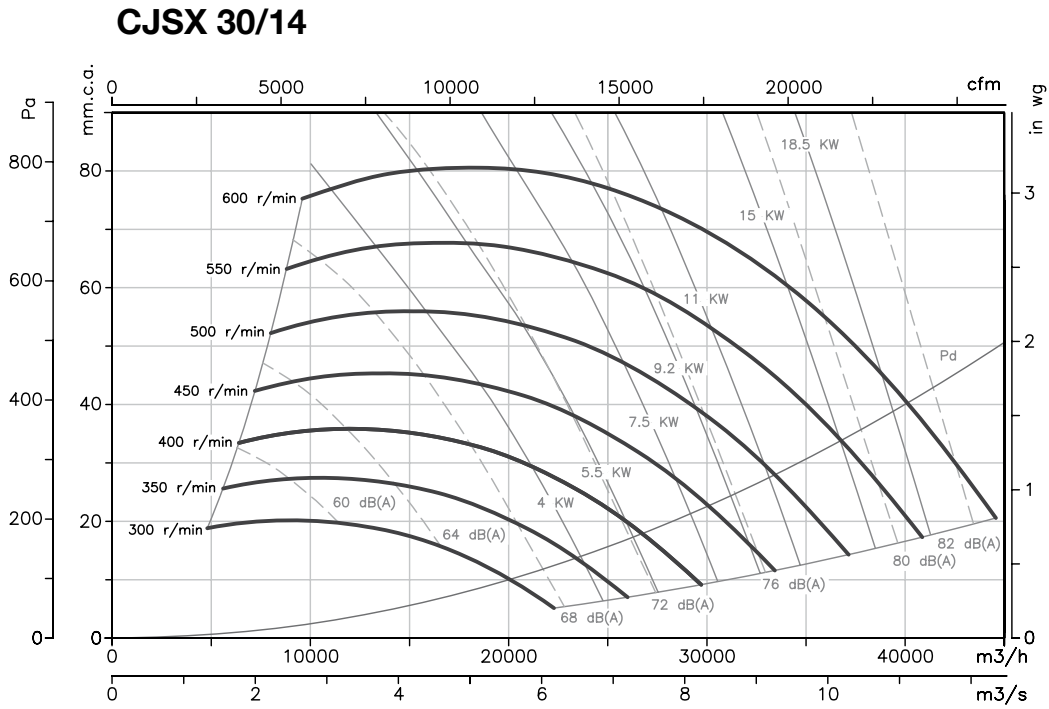

**Accessories**

See accessories section



# CSX CJSRX



CSX



CJSRX

## 400°C/2h centrifugal belt-driven fans and extraction units to work outside fire danger zones with backward-curved impeller

CSX: 400°C/2h centrifugal belt-driven fans with backward-curved impeller.

CJSRX: 400°C/2h belt-driven extraction units with backward-curved impeller.

### Fan:

- Steel sheet casing
- Impeller with backward-curved blades made from sheet steel
- Approval according to Standard EN-12101-3:2002, certificate no.: 0370-CPD-
- Protective anti-contact guard

### Motor:

- Class F motors with ball bearings, IP55 protection
- Three-phase 230/400V.-50Hz. (up to 5.5CV.) and 400/690V.-50Hz. (power over 5.5CV.)
- Max. temperature of air for transport: S1 Service -20°C to + 150°C for ongoing use, S2 Service 200°C/2h, 300°C/2h and 400°C/2h

### Finish:

- Anticorrosive galvanized sheet steel.

### On request:

- Special windings for different voltages
- Fan designed to transport air up to 100°C
- Fans with two-speed motor.



High-performance and robust backward-curved impeller.

## Order Code

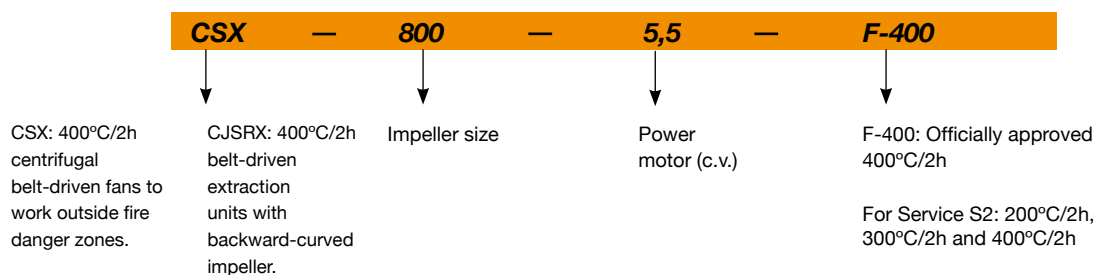

## Technical characteristics

Model	Speed (r/min)	Maximum admissible current (A)			Power installed (kW)	Airflow maximum (m³/h)	Approx. weight (Kg)	
		230V	400V (A)	690V				
CSX CJSRX	315-0,75	1880	2,35	1,35	-	0,55	3075	32
CSX CJSRX	315-1	2095	3,13	1,80	-	0,75	3430	34
CSX CJSRX	315-1,5	2375	4,35	2,50	-	1,10	3885	36
CSX CJSRX	315-2	2655	5,83	3,35	-	1,50	4345	39
CSX CJSRX	315-3	3000	7,60	4,37	-	2,20	4910	42
CSX CJSRX	355-0,75	1580	2,43	1,40	-	0,55	3685	41
CSX CJSRX	355-1	1765	3,13	1,80	-	0,75	4120	44

## Technical characteristics

Model		Speed (r/min)	Maximum admissible current (A)			Power installed (kW)	Airflow maximum (m³/h)	Approx. weight (Kg)	
			230V	400V (A)	690V				
CSX	CJSRX	355-1,5	2010	4,35	2,50	-	1,10	4690	46
CSX	CJSRX	355-2	2225	5,83	3,35	-	1,50	5190	48
CSX	CJSRX	355-3	2530	7,60	4,37	-	2,20	5905	53
CSX	CJSRX	355-4	2860	10,35	5,95	-	3,00	6675	57
CSX	CJSRX	400-0,75	1320	2,35	1,35	-	0,55	4375	49
CSX	CJSRX	400-1	1465	3,30	1,90	-	0,75	4855	52
CSX	CJSRX	400-1,5	1665	4,50	2,59	-	1,10	5515	54
CSX	CJSRX	400-2	1845	5,83	3,35	-	1,50	6110	56
CSX	CJSRX	400-3	2100	7,60	4,37	-	2,20	6955	59
CSX	CJSRX	400-4	2370	10,35	5,95	-	3,00	7850	64
CSX	CJSRX	400-5,5	2610	13,22	7,60	-	4,00	8645	72
CSX	CJSRX	450-0,75	1095	2,43	1,40	-	0,55	5045	61
CSX	CJSRX	450-1	1220	3,30	1,90	-	0,75	5620	64
CSX	CJSRX	450-1,5	1390	4,50	2,59	-	1,10	6405	66
CSX	CJSRX	450-2	1540	6,00	3,45	-	1,50	7095	68
CSX	CJSRX	450-3	1750	8,35	4,80	-	2,20	8065	72
CSX	CJSRX	450-4	1980	10,35	5,95	-	3,00	9120	76
CSX	CJSRX	450-5,5	2180	13,22	7,60	-	4,00	10045	85
CSX	CJSRX	450-7,5	2420	-	10,50	6,09	5,50	11150	95
CSX	CJSRX	450-10	2670	-	13,90	8,06	7,50	12300	100
CSX	CJSRX	450-12,5	2800	-	16,80	9,74	9,20	12900	108
CSX	CJSRX	500-1,5	1140	4,50	2,59	-	1,10	7330	88
CSX	CJSRX	500-2	1270	6,00	3,45	-	1,50	8165	90
CSX	CJSRX	500-3	1445	8,35	4,80	-	2,20	9290	93
CSX	CJSRX	500-4	1635	11,27	6,48	-	3,00	10510	98
CSX	CJSRX	500-5,5	1800	13,91	8,00	-	4,00	11570	107
CSX	CJSRX	500-7,5	2000	-	11,10	6,43	5,50	12855	116
CSX	CJSRX	500-10	2220	-	13,90	8,06	7,50	14270	121
CSX	CJSRX	500-12,5	2375	-	16,80	9,74	9,20	15270	130
CSX	CJSRX	500-15	2525	-	20,50	11,88	11,00	16230	156
CSX	CJSRX	560-2	1035	6,00	3,45	-	1,50	9885	100
CSX	CJSRX	560-3	1185	8,35	4,80	-	2,20	11360	103
CSX	CJSRX	560-4	1340	11,27	6,48	-	3,00	12880	108
CSX	CJSRX	560-5,5	1475	13,91	8,00	-	4,00	14210	117
CSX	CJSRX	560-7,5	1640	-	11,10	6,43	5,50	15830	122
CSX	CJSRX	560-10	1815	-	14,80	8,58	7,50	17555	132
CSX	CJSRX	560-12,5	1945	-	16,80	9,74	9,20	18830	141
CSX	CJSRX	560-15	2065	-	20,50	11,88	11,00	20010	166
CSX	CJSRX	630-3	1010	8,35	4,80	-	2,20	12120	119
CSX	CJSRX	630-4	1140	11,27	6,48	-	3,00	13680	123
CSX	CJSRX	630-5,5	1255	13,91	8,00	-	4,00	15060	132
CSX	CJSRX	630-7,5	1395	-	11,10	6,43	5,50	16740	138
CSX	CJSRX	630-10	1550	-	14,80	8,58	7,50	18600	147
CSX	CJSRX	630-12,5	1660	-	17,50	10,14	9,20	19920	156
CSX	CJSRX	630-15	1760	-	22,00	12,75	11,00	21120	181
CSX	CJSRX	630-20	1980	-	29,00	16,81	15,00	23760	202
CSX	CJSRX	710-4	960	11,27	6,48	-	3,00	17065	186
CSX	CJSRX	710-5,5	1060	13,91	8,00	-	4,00	18845	195
CSX	CJSRX	710-7,5	1180	-	11,10	6,43	5,50	20980	200
CSX	CJSRX	710-10	1305	-	14,80	8,58	7,50	23200	210
CSX	CJSRX	710-12,5	1400	-	17,50	10,14	9,20	24890	219
CSX	CJSRX	710-15	1485	-	22,00	12,75	11,00	26400	244
CSX	CJSRX	710-20	1670	-	29,00	16,81	15,00	29690	265
CSX	CJSRX	710-25	1790	-	36,50	21,16	18,50	31820	285
CSX		800-4	765	11,27	6,48	-	3,00	19975	226
CSX		800-5,5	845	13,91	8,00	-	4,00	22065	234
CSX		800-7,5	940	-	11,10	6,43	5,50	24545	240
CSX		800-10	1040	-	14,80	8,58	7,50	27155	250
CSX		800-12,5	1115	-	17,50	10,14	9,20	29115	259
CSX		800-15	1185	-	22,00	12,75	11,00	30940	284
CSX		800-20	1330	-	29,00	16,81	15,00	34730	305
CSX		800-25	1425	-	36,50	21,16	18,50	37210	325
CSX		800-30	1510	-	42,00	24,35	22,00	39430	344
CSX		900-4	640	11,27	6,48	-	3,00	21200	281
CSX		900-5,5	705	13,91	8,00	-	4,00	23355	289
CSX		900-7,5	785	-	11,10	6,43	5,50	26005	295

**Technical characteristics**

Model		Speed (r/min)	Maximum admissible current (A)			Power installed (kW)	Airflow maximum (m³/h)	Approx. weight (Kg)
			230V	400V (A)	690V			
CSX	900-10	870	-	14,80	8,58	7,50	28820	305
CSX	900-12,5	930	-	17,50	10,14	9,20	30805	314
CSX	900-15	990	-	22,00	12,75	11,00	32795	339
CSX	900-20	1110	-	29,00	16,81	15,00	36770	360
CSX	900-25	1190	-	36,50	21,16	18,50	39420	380
CSX	900-30	1260	-	42,00	24,35	22,00	41740	399
CSX	900-40	1400	-	59,00	34,2	30,00	46375	453
CSX	1000-5,5	575	13,91	8,00	-	4,00	25555	342
CSX	1000-7,5	645	-	11,10	6,43	5,50	28665	348
CSX	1000-10	715	-	14,80	8,58	7,50	31780	358
CSX	1000-12,5	765	-	17,50	10,14	9,20	34000	366
CSX	1000-15	815	-	22,00	12,75	11,00	36220	392
CSX	1000-20	915	-	29,00	16,81	15,00	40665	413
CSX	1000-25	980	-	36,50	21,16	18,50	43555	432
CSX	1000-30	1040	-	42,00	24,35	22,00	46220	452
CSX	1000-40	1150	-	59,00	34,2	30,00	51110	506
CSX	1000-50	1200	-	68,00	39,42	37,00	53335	549

**Dimensions in mm**

RD 90 standard supply

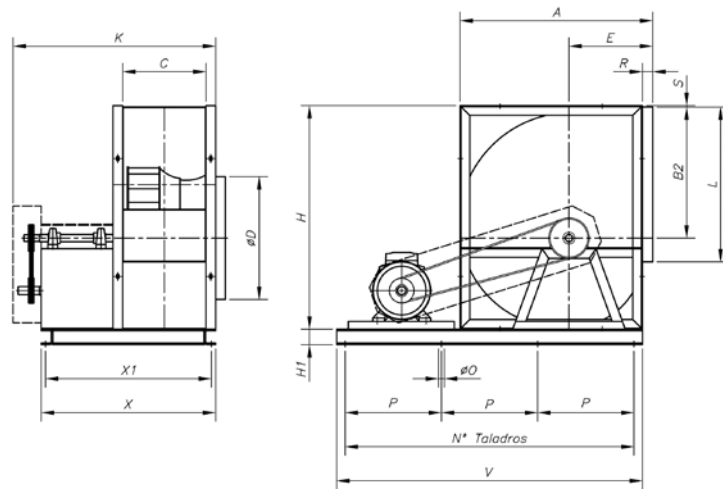

	A	B2	C	øD	E	H	H1	K	L	øO	P	N° Taladros	R	S	V	X	X1
CSX-315	518	340	223	322	236	578	80	630	404	12	440	3	38	3	920	590	550
CSX-355	578	383	247	362	261	655	80	720	453	12	470	3	30	6	980	630	590
CSX-400	651	431,5	274	404	290	736	80	750	507	12	530	3	38	4,5	1100	676	636
CSX-450	726	486	308	448	322	827	80	858	569	12	580	3	45	5	1200	728	688
CSX-500	800	538	344	510	352	918	80	885	638	12	620	3	50	5	1280	764	724
CSX-560	893	603	383	570	390	1030	80	980	715	12	680	3	48	8	1400	855	815
CSX-630	999	678,5	432	635	434	1157	80	1040	801	12	503	4	53	7	1550	904	864
CSX-710	1121	765	478	722	485	1303	80	1150	898	12	553	4	63	7	1700	1030	985
CSX-800	1250	862	533	808	535	1468	80	1220	1007	12	613	4	69	7	1880	1084	1034
CSX-900	1408	971	595	896	604	1648	80	1390	1130	12	502,5	5	89	7	2050	1196	1136
CSX-1000	1541	1066	663	996	657	1810	80	1450	1267	12	552,5	5	79	9	2050	1305	1255

## Dimensions in mm

Standard supply  
horizontal outlet (H) RD 90

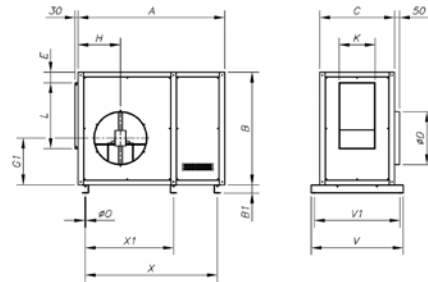

On request  
horizontal outlet (H) LG 90

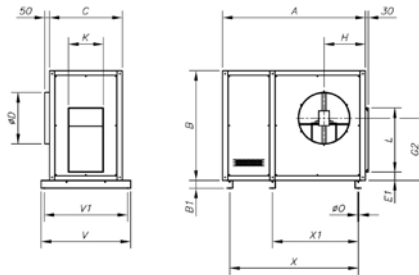

On request  
vertical outlet (V) RD 0

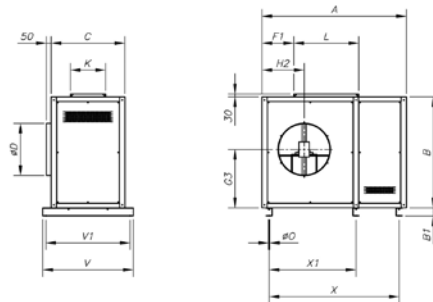

On request  
vertical outlet (V) LG 0

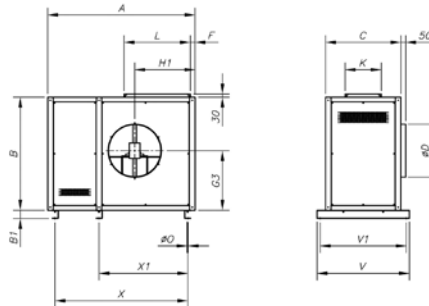

	A	B	B1	C	ØD	E	E1	F	F1	G1	G2	G3	H	H1	H2	L	K	ØD	V	V1	X	X1
CJSRX-315	950	740	60	560	315	81	82	43,5	211,5	316	424	363	307,5	386	278	409	228	15	727	647	808	-
CJSRX-355	1080	785	60	610	365	77	85	46,5	236,5	347	470	398	340,5	432	309	458	252	15	777	697	938	-
CJSRX-400	1200	900	60	645	405	84	82	44	264	381	517	442	361,5	479	343	514	280	15	812	732	1058	-
CJSRX-450	1355	980	60	695	450	74	83	45	293	417	572	485	386,5	534	379	575	314	15	857	777	1213	-
CJSRX-500	1430	1100	60	730	515	103	83	45	315	456	624	579	413,5	585	415	644	350	15	897	817	1289	-
CJSRX-560	1600	1250	60	800	575	143	85,5	47,5	346,5	501	691	584	451	653	463	721	390	15	967	887	1458	958
CJSRX-630	1720	1350	60	850	640	116	85	47	389	553	766,5	646	492,5	728,5	515,5	807	438	15	1017	937	1579	1100
CJSRX-710	1928	1530	60	943	725	140	95	47	440	622	863	727	533,5	815	574	904	484	15	1110	1030	1787	1208,5

**Characteristic curves**

Q = Airflow in m<sup>3</sup>/h, m<sup>3</sup>/s and cfm.

Pe = Static pressure in mm.w.c., Pa and inwg.

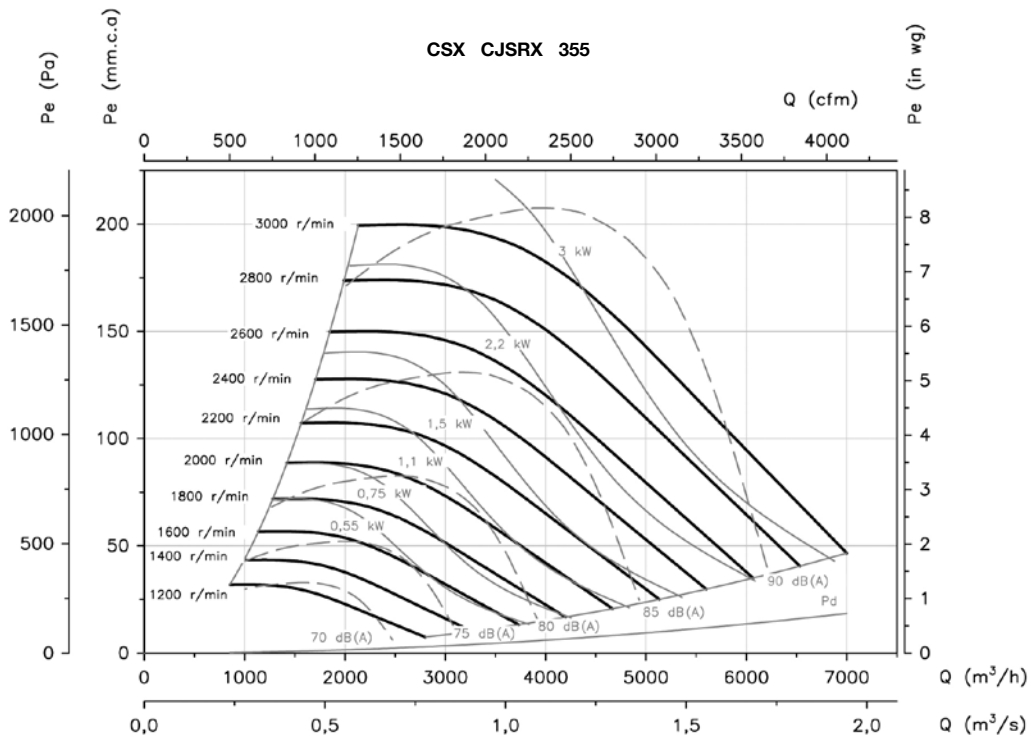
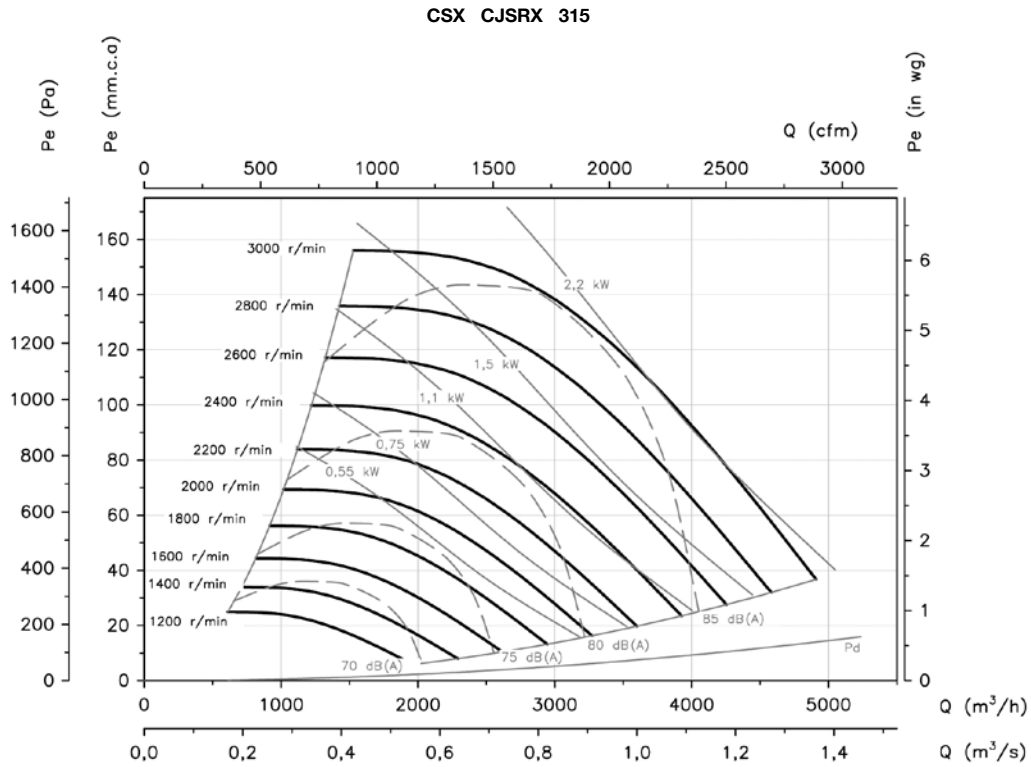

## Characteristic curves

Q = Airflow in m<sup>3</sup>/h, m<sup>3</sup>/s and cfm.

Pe = Static pressure in mm.w.c., Pa and inwg.

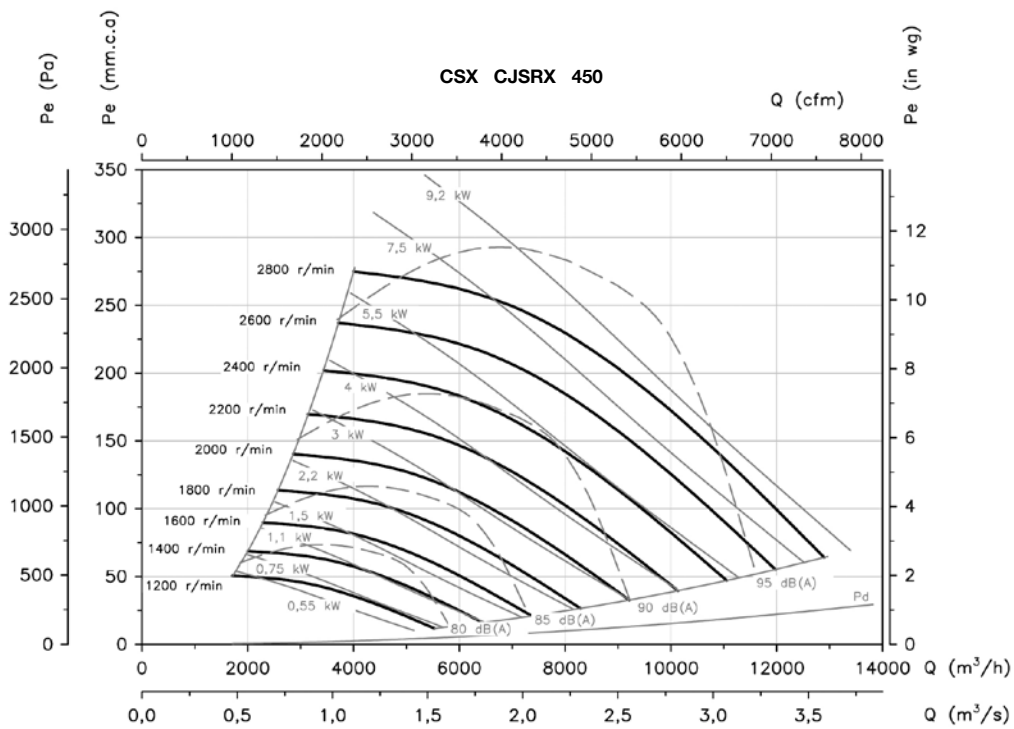
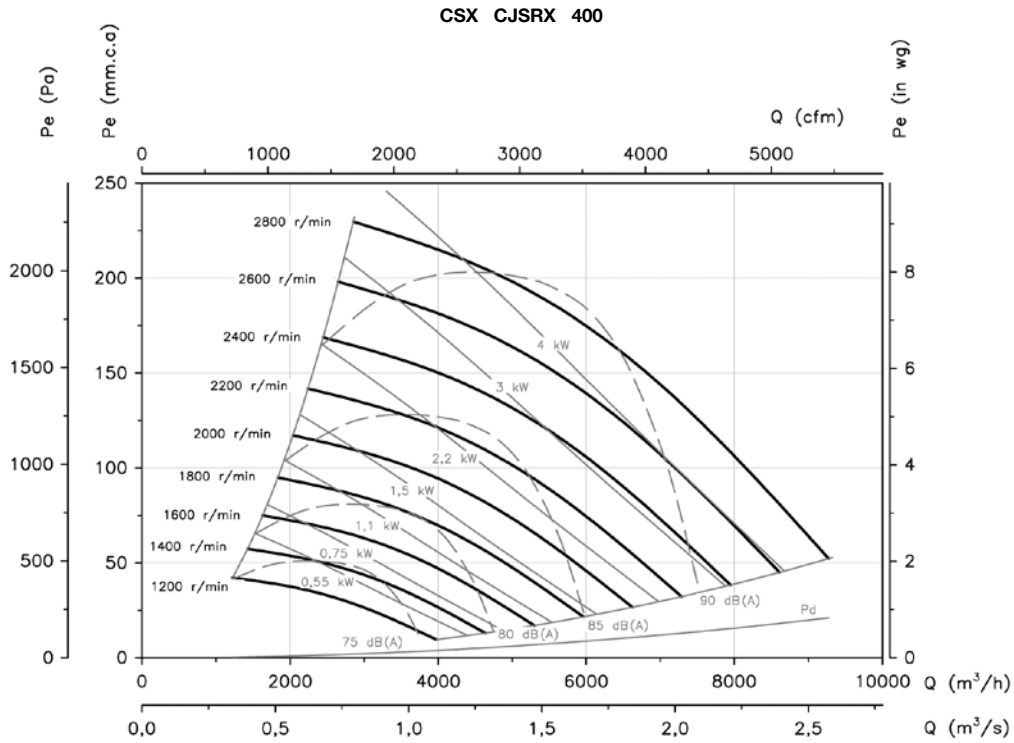

**Characteristic curves**

Q = Airflow in m<sup>3</sup>/h, m<sup>3</sup>/s and cfm.

Pe = Static pressure in mm.w.c., Pa and inwg.

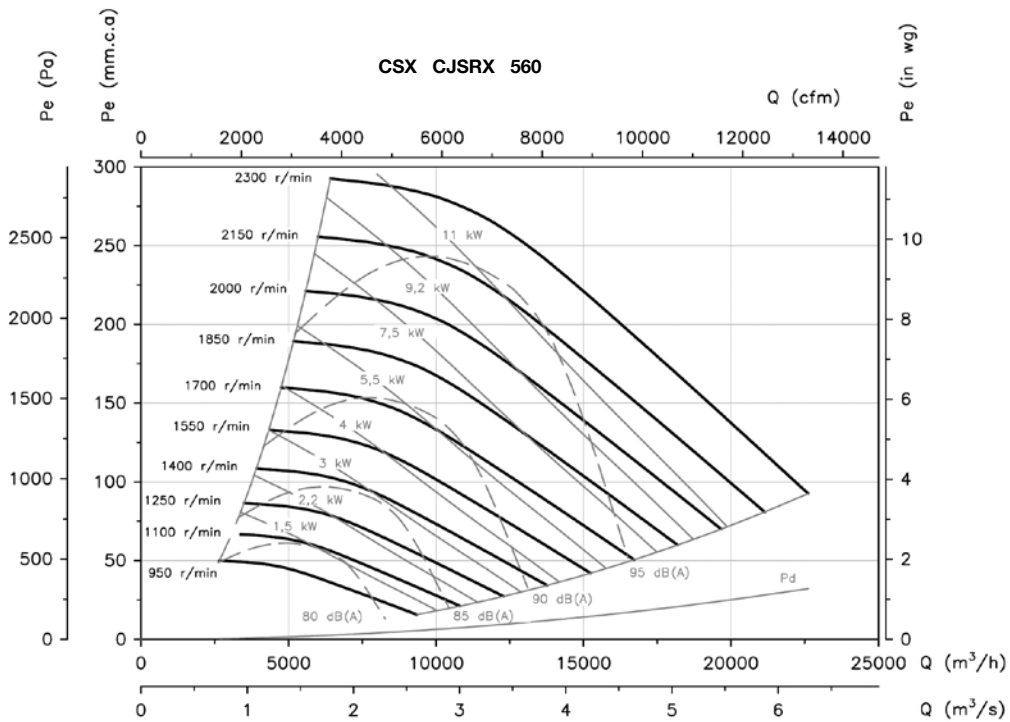
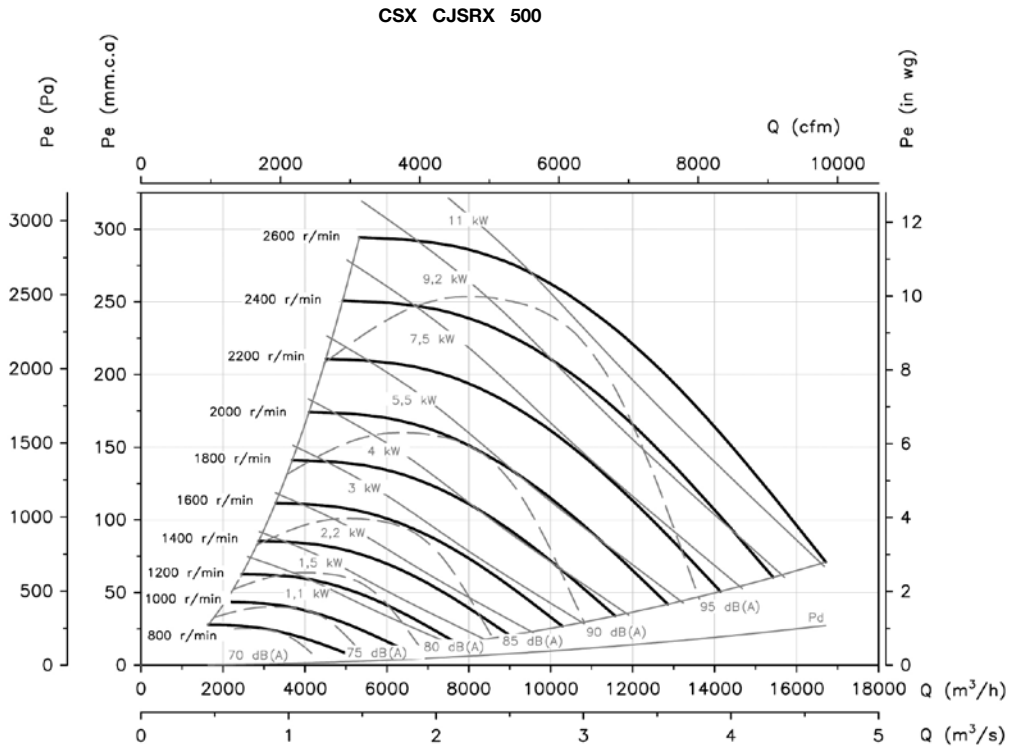

## Characteristic curves

Q = Airflow in m<sup>3</sup>/h, m<sup>3</sup>/s and cfm.

Pe = Static pressure in mm.w.c., Pa and inwg.

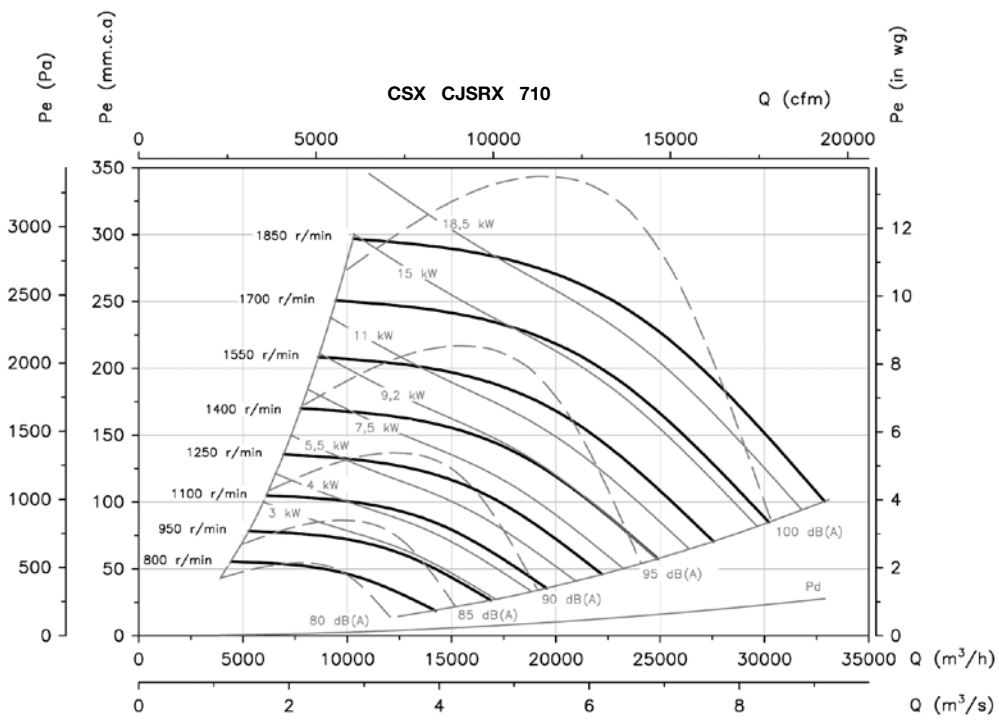
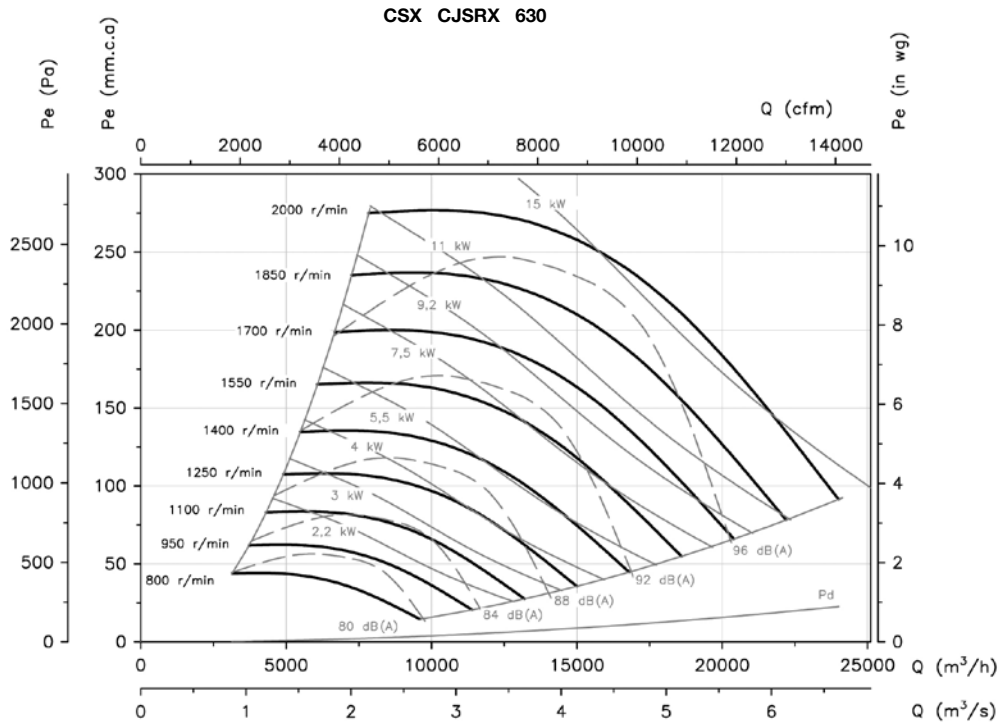

**Characteristic curves**

Q= Airflow in m<sup>3</sup>/h, m<sup>3</sup>/s and cfm.

Pe= Static pressure in mm. w.c., Pa and inwg.

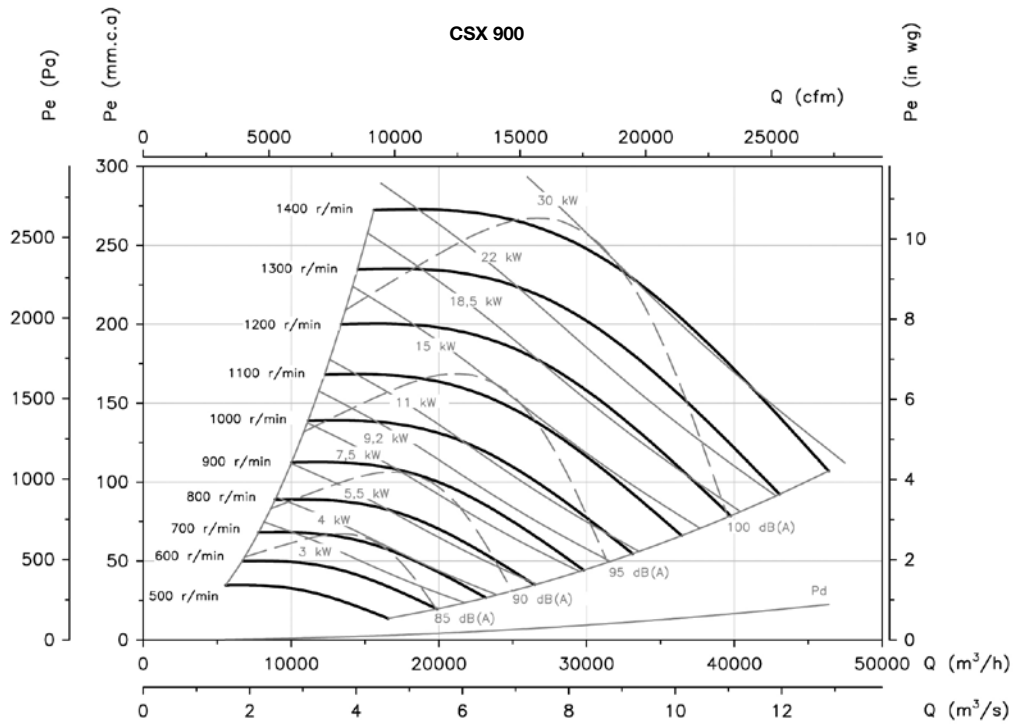
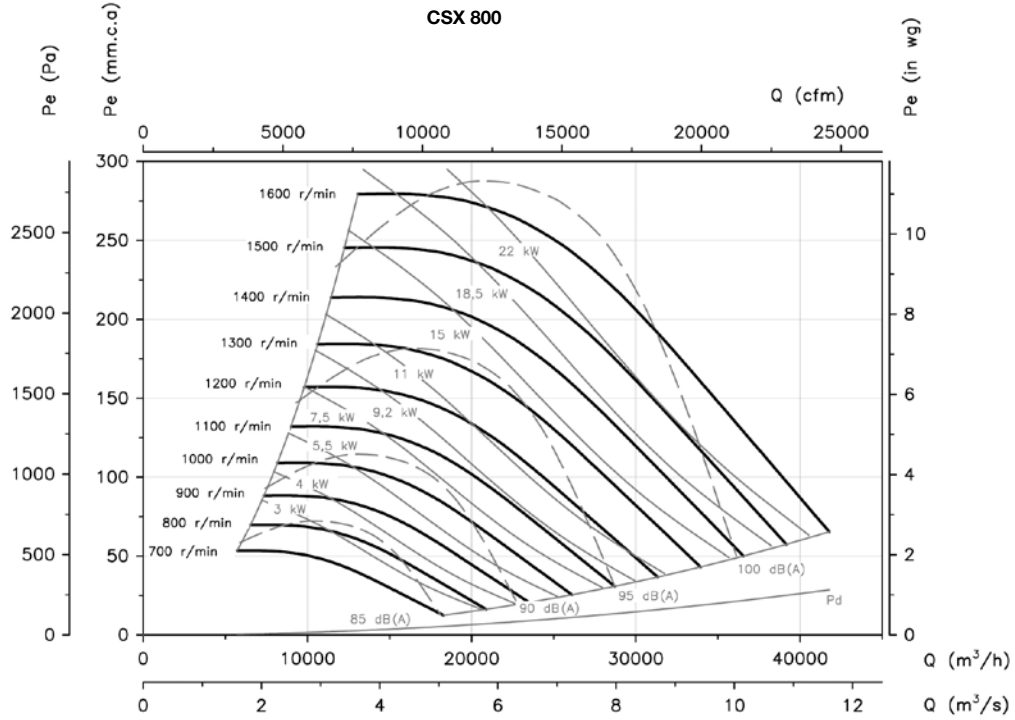

**Characteristic curves**

Q = Airflow in m<sup>3</sup>/h, m<sup>3</sup>/s and cfm.

Pe= Static pressure in mm.w.c., Pa and inwg.

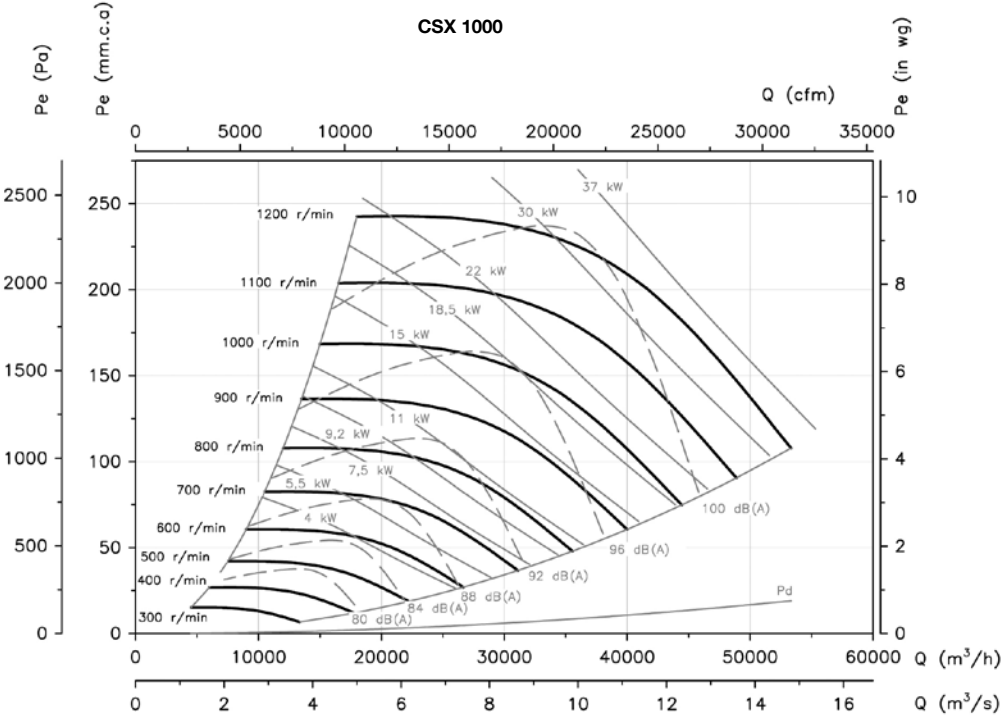

**Accessories**

See accessories section



# CJLINE

## 400°C/2h extraction units with linear inlet and outlet



Easy to connect to rectangular ducts.

400°C/2h in-line extraction units to work outside the fire danger zone.

### Fan:

- Galvanized sheet steel structure.
- Impeller with backward-curved blades made from sheet steel
- Approval according to Standard EN-12101-3-2002, certificate no.: 0370-CPD-0594
- Linear air circulation

### Motor:

- Class F motors with ball bearings, IP55 protection, one-or two-speed depending on the model
- Three-phase 230/400V.-50Hz. (up to 5.5CV.) and 400/690V.-50Hz. (power over 5.5CV.)
- Max. temperature of air for transport: S1 Service -20°C+ 120°C for ongoing use, S2 Service 200°C/2h, 300°C/2h and 400°C/2h

### Finish:

- Anticorrosive galvanized sheet steel.

### On request:

- Fans with two-speed motor.



## Order code

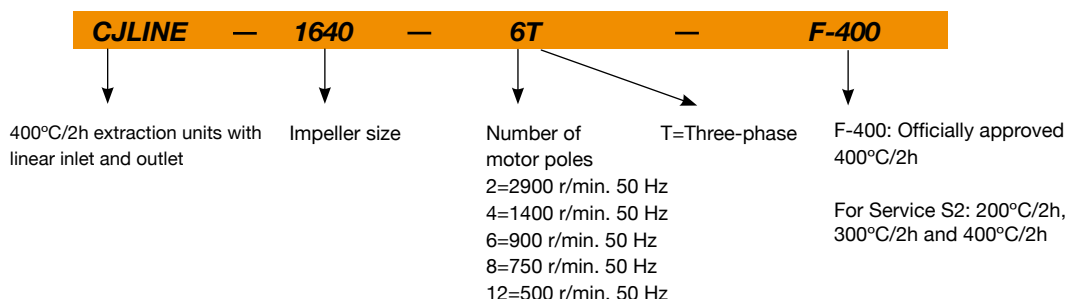

## Technical characteristics

Model	Speed (r/min)	Maximum admissible current (A)			Power installed (kW)	Airflow maximum (m³/h)	Sound pressure level dB(A)	Approx. weight (Kg)
		230V	400V (A)	690V				
CJLINE-1131-4T	1350	1.45	0.84		0.25	1920	51	39
CJLINE-1131-4/8T	1400 / 700		0.70 / 0.30		0.25 / 0.10	1920 / 960	51 / 36	40
CJLINE-1235-4T	1350	1.45	0.84		0.25	3550	56	54
CJLINE-1235-4/8T	1400 / 700		0.70 / 0.30		0.25 / 0.10	3550 / 1775	56 / 41	55
CJLINE-1235-6T	880	1.22	0.70		0.18	2300	50	55
CJLINE-1640-4T	1370	1.92	1.11		0.37	4800	61	65
CJLINE-1640-4/8T	1440 / 700		1.05 / 0.50		0.37 / 0.11	4800 / 2400	61 / 46	67
CJLINE-1640-6T	900	1.51	0.87		0.25	2950	54	66
CJLINE/H-1650-4T	1400	5.97	3.45		1.50	9650	74	99
CJLINE-1845-4T	1380	3.34	1.93		0.75	6700	65	83
CJLINE-1845-4/8T	1425 / 710		2.30 / 0.90		0.75 / 0.12	6700 / 3350	65 / 50	84
CJLINE-1845-6T	900	2.13	1.23		0.37	4360	57	81
CJLINE/H-1856-4T	1420	11.21	6.47		3.00	13580	77	117
CJLINE-1856-6T	900	2.85	1.65		0.55	7720	59	142
CJLINE-1856-6/12T	930 / 450		1.60 / 0.65		0.55 / 0.09	7720 / 3860	59 / 44	143
CJLINE-1856-8T	680	1.83	1.06		0.25	5800	52	143
CJLINE/H-2063-4T	1450		11.03	6.37	5.50	20900	79	228
CJLINE-2063-6T	920	3.77	2.18		0.75	11100	61	185

## Technical characteristics

Model	Speed (r/min)	Maximum admissible current (A)			Power installed (kW)	Airflow maximum (m³/h)	Sound pressure level dB(A)	Approx. weight (Kg)
		230V	400V (A)	690V				
CJLINE-2063-6/12T	935 / 435		2.20 / 0.87		0.75/ 0.15	11100 / 5550	61 / 46	190
CJLINE-2063-8T	680	2.33	1.35		0.37	7730	54	188
CJLINE/H-2271-4T	1460		20.64	11.92	11.00	31170	84	283
CJLINE-2271-6T	945	6.67	3.85		1.50	14300	65	205
CJLINE-2271-6/12T	970 / 470		4.60 / 1.90		1.50/ 0.25	14300 / 7150	65 / 50	216
CJLINE-2271-8T	710	4.24	2.45		0.75	9900	57	204
CJLINE-2880-6T	960	12.49	7.21		3.00	22800	67	275
CJLINE-2880-6/12T	960 / 480		9.00 / 3.50		3.00/ 0.55	22800 / 11400	67 / 52	289
CJLINE-2880-8T	720	10.33	5.96		2.20	17200	58	275

## Acoustic features

The specified values are determined according to free field measurements of pressure and sound levels in dB(A) at an equivalent distance of twice the fan's span plus the turbine's diameter, with a minimum of 1.5 m.

Sound power Lw(A) spectrum in dB(A) via frequency band in Hz.

Model	63	125	250	500	1000	2000	4000	8000	Model	63	125	250	500	1000	2000	4000	8000
CJLINE 1131-4	42	51	57	56	60	60	52	46	CJLINE 1856-8	51	57	62	63	66	65	58	53
CJLINE 1131-8	27	36	42	41	45	45	37	31	CJLINE 1856-12	43	49	54	55	58	57	50	45
CJLINE 1235-4	49	58	64	63	67	66	59	53	CJLINE/H 2063-4	81	86	93	94	93	90	83	75
CJLINE 1235-6	43	52	58	57	61	60	53	47	CJLINE 2063-6	60	66	72	72	76	76	68	61
CJLINE 1235-8	34	43	59	48	52	51	44	38	CJLINE 2063-8	53	59	65	65	69	69	61	54
CJLINE 1640-4	56	62	67	68	71	73	65	59	CJLINE 2063-12	45	51	57	57	61	61	53	46
CJLINE 1640-6	49	55	60	61	64	66	58	52	CJLINE/H 2271-4	83	84	93	96	99	99	95	82
CJLINE 1640-8	41	47	52	53	56	58	50	44	CJLINE 2271-6	64	70	76	76	80	80	72	65
CJLINE/H 1650	64	74	82	84	83	85	76	66	CJLINE 2271-8	56	62	68	68	72	72	64	57
CJLINE 1845-4	60	66	71	72	75	77	69	63	CJLINE 2271-12	49	55	61	61	65	65	57	50
CJLINE 1845-6	52	58	63	64	67	69	61	55	CJLINE 2880-6	66	72	78	78	82	82	74	67
CJLINE 1845-8	45	51	56	57	60	62	54	48	CJLINE 2880-8	57	63	69	69	73	73	65	58
CJLINE 1856-6	58	64	69	70	73	72	65	60	CJLINE 2880-12	51	57	63	63	67	67	59	52
CJLINE/H 1856-4	69	77	91	87	90	90	85	71									

## Dimensions in mm

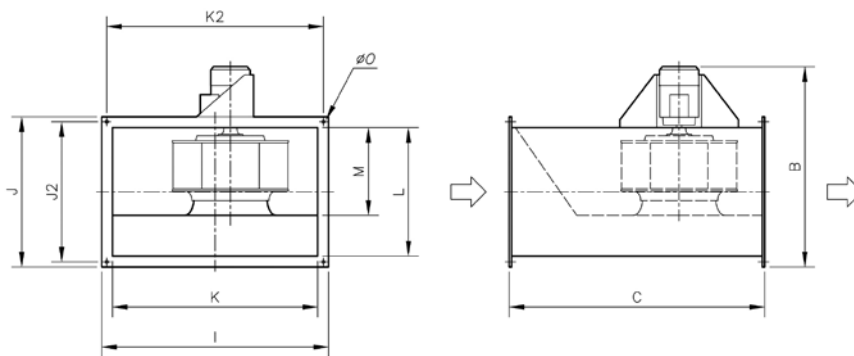

Model	B	C	I	J	J2	K	k2	L	M	ØO
CJLINE-1131	760	710	620	510	483	560	593	450	175	10
CJLINE-1235	830	800	680	560	533	620	653	500	213	10
CJLINE-1640	890	900	770	620	593	710	743	560	262	10
CJLINE-1650/H	942	1000	860	690	663	800	833	630	290	10
CJLINE-1845	1010	1000	860	690	663	800	833	630	290	10
CJLINE-1856	1280	1250	1060	860	833	1000	1033	800	378	10
CJLINE-1856/H	1150	1250	1060	860	833	1000	1033	800	378	10
CJLINE-2063	1390	1400	1205	980	938	1125	1163	900	378	12
CJLINE-2063/H	1320	1400	1205	980	938	1125	1163	900	378	12
CJLINE-2271	1470	1400	1270	980	938	1190	1228	900	378	12
CJLINE-2271/H	1518	1400	1270	980	938	1190	1228	900	378	12
CJLINE-2880	1590	1500	1330	1080	1038	1250	1288	1000	490	12

**Characteristic curves**

Q = Airflow in m<sup>3</sup>/h, m<sup>3</sup>/s and cfm.

Pe = Static pressure in mm.w.c., Pa and inwg.

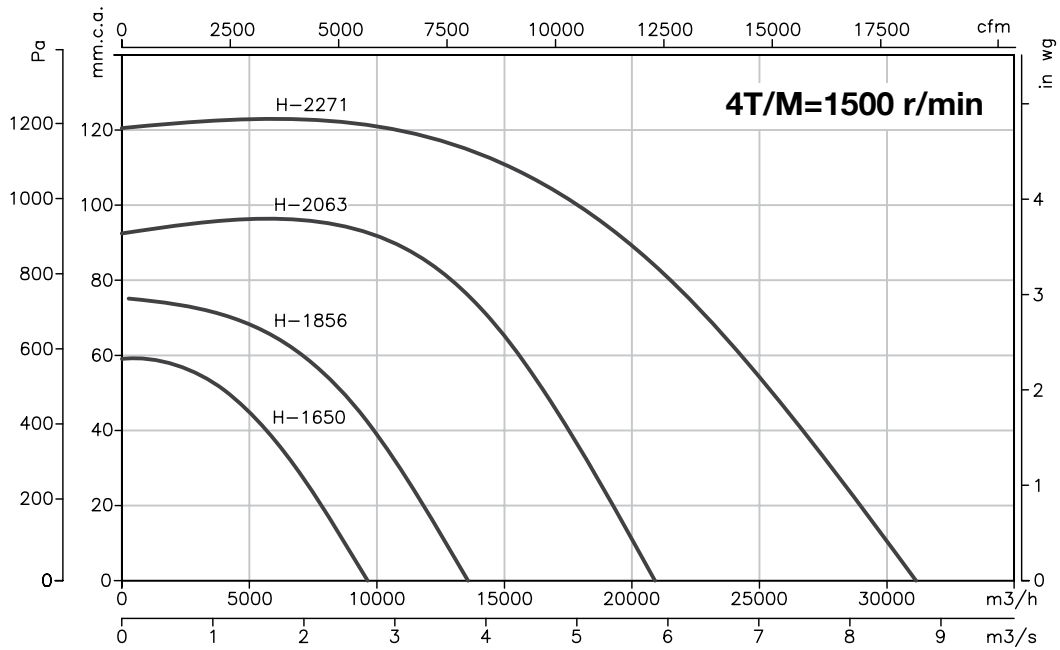
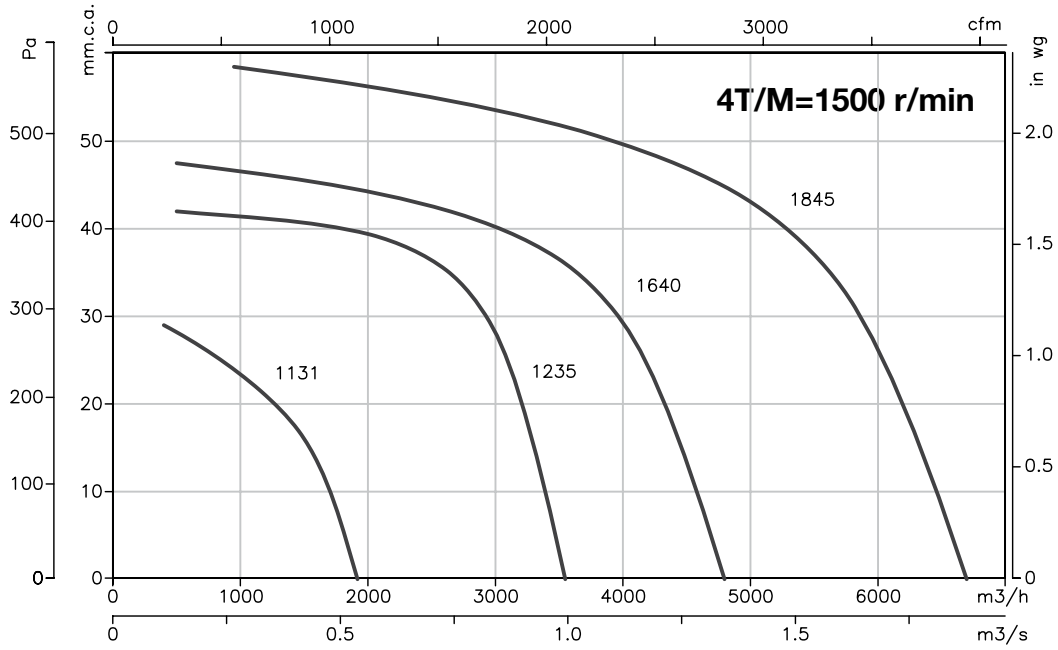

**Characteristic curves**

Q = Airflow in m<sup>3</sup>/h, m<sup>3</sup>/s and cfm.

Pe = Static pressure in mm.w.c., Pa and inwg.

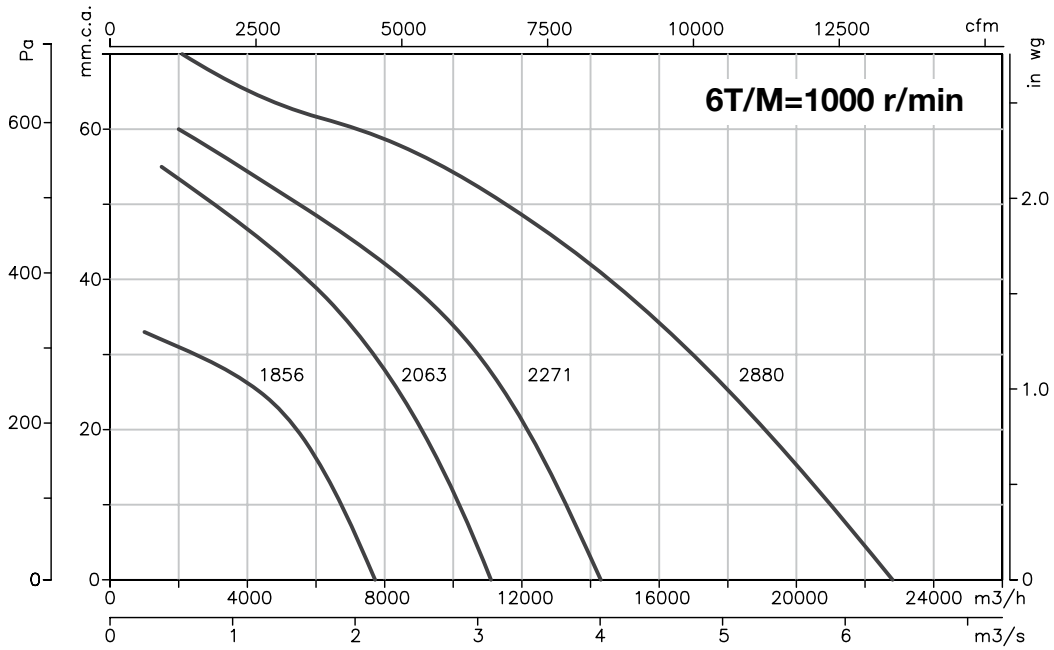
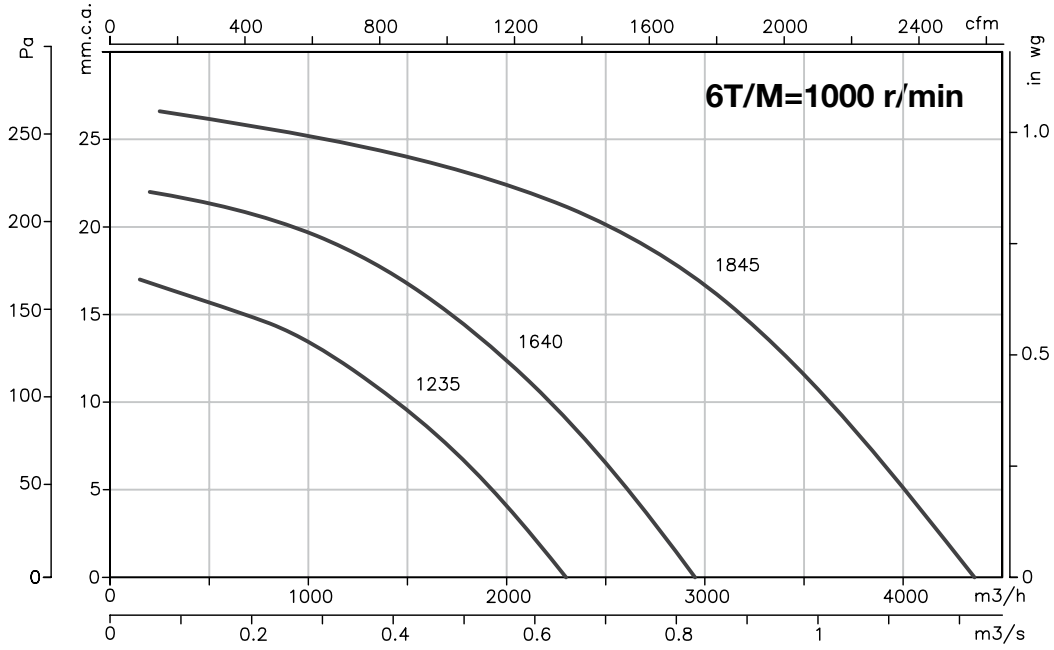

**Characteristic curves**

Q = Airflow in m<sup>3</sup>/h, m<sup>3</sup>/s and cfm.

Pe= Static pressure in mm.w.c., Pa and inwg.

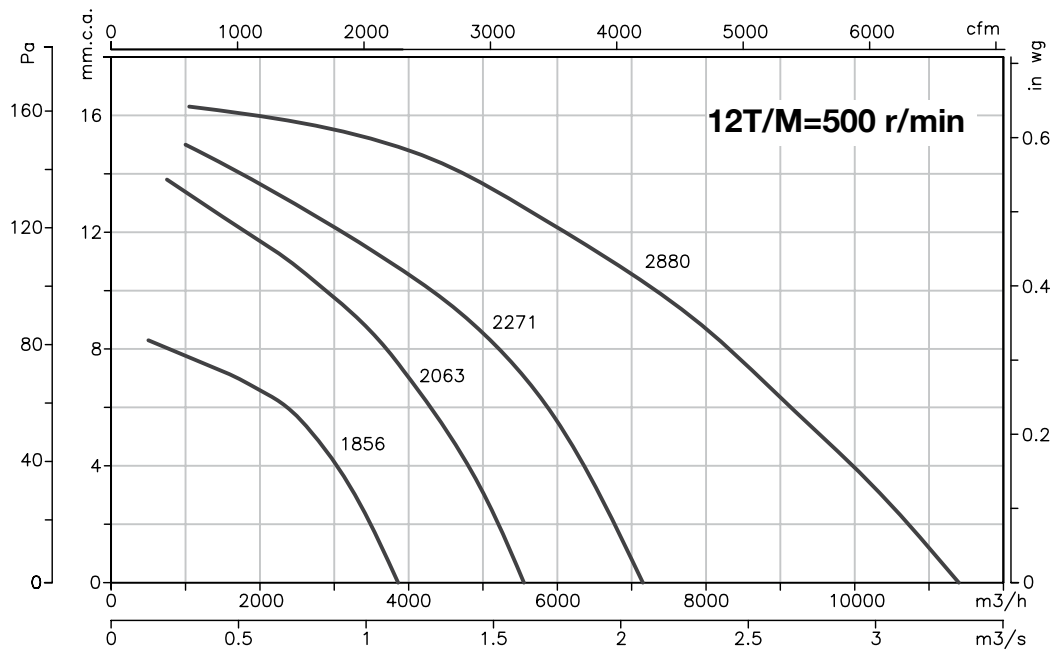
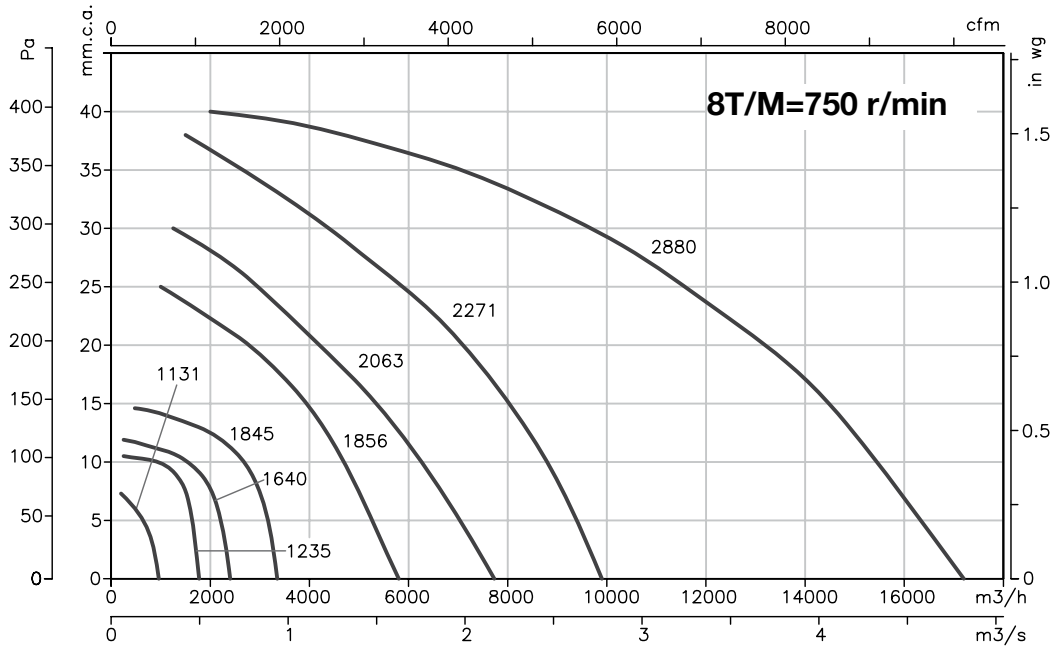

**Accessories**

See accessories section



INT

CABLE BOX

C2V

AET

AR

CENTRAL CO

RFT

TAC

VIS

# CJEC



Motor-impeller unit easy to dismantle

## Extraction units with large hatch to facilitate maintenance.

Extraction units with large hatch to facilitate maintenance.

### Fan:

- Galvanized sheet steel structure.
- Impeller with backward-curved blades made from galvanized sheet steel
- Approval according to Standard EN-12101-3-2002 certification No.: 0370-CPD-0382
- Possibility of mounting the outlet on either side of the box during installation.

### Motor:

- Single-phase two-speed motors with IE-2 efficiency, except lower powers 0.75 kW
- Class F two-speed motors with ball bearings, IP55 protection
- Three-phase 400V.-50Hz. DHALANDER
- Max. temperature of air for transport: -20°C.+ 120°C.

### Finish:

- Anticorrosive galvanized sheet steel.

### On request:

- With single-speed motors.



## Order code

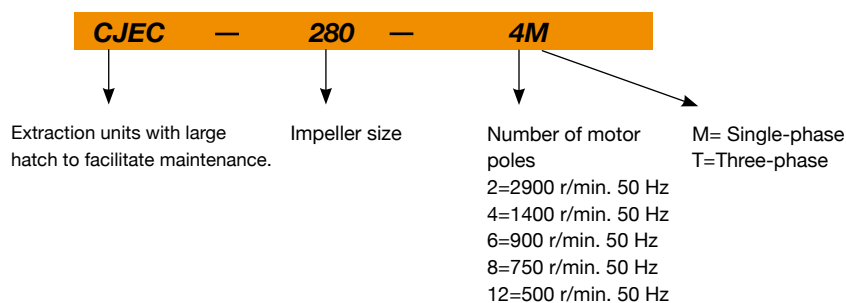

## Technical characteristics

Model	Speed (r/min)	Maximum admissible current (A)		Power installed (kW)	Airflow maximum (m³/h)	Sound level dB(A)		Approx. weight (Kg)
		230V	400V (A)			Inlet	Outlet	
CJEC-280-4/8T	1380 / 720		0.60 / 0.70	0.18 / 0.04	1370 / 685	55 / 40	60 / 45	61
CJEC-280-4M	1380	0.65		0.10	1370	55	60	61
CJEC-315-4/8T	1430 / 640		0.80 / 0.40	0.25 / 0.06	1650 / 825	59 / 44	63 / 48	63
CJEC-315-4M	1400	0.95		0.18	1650	59	63	63
CJEC-355-4/8T	1360 / 700		1.10 / 0.50	0.37 / 0.09	3000 / 1500	61 / 46	66 / 51	75
CJEC-355-4M	1360	1.35		0.25	3000	61	66	75
CJEC-400-4/8T	1410 / 680		1.80 / 0.65	0.55 / 0.13	4000 / 2000	65 / 50	69 / 54	79
CJEC-400-4M	1380	3.30		0.55	4000	65	69	79
CJEC-450-4/8T	1400 / 675		2.15 / 0.75	0.75 / 0.17	5500 / 2750	68 / 53	72 / 57	89
CJEC-450-4M	1380	4.40		0.75	5500	68	72	89
CJEC-500-4/8T	1390 / 700		4.00 / 1.60	1.70 / 0.35	7600 / 3800	70 / 55	75 / 60	110
CJEC-560-6/12T	940 / 460		3.50 / 1.20	1.30 / 0.20	9500 / 4750	77 / 62	82 / 67	129

**Acoustic features**

The specified values are determined according to free field measurements of pressure and sound levels in dB(A) at an equivalent distance of twice the fan's span plus the turbine's diameter, with a minimum of 1.5 m.

Sound power Lw(A) spectrum in dB(A) via frequency band in Hz.

Values taken at inlet with maximum airflow.								Values taken at outlet with maximum airflow.									
Model	63	125	250	500	1000	2000	4000	8000	Model	63	125	250	500	1000	2000	4000	8000
280-4	42	47	62	59	60	58	53	45	280-4	42	45	65	66	65	65	58	49
280-8	27	32	47	44	45	43	38	30	280-8	27	30	50	51	50	50	43	34
315-4	53	62	64	64	64	62	54	42	315-4	45	59	67	69	68	68	60	53
315-8	38	47	49	49	49	47	39	27	315-8	30	44	52	54	53	53	45	38
355-4	52	62	68	63	64	66	62	53	355-4	48	67	68	71	72	71	64	55
355-8	37	47	53	48	49	51	47	38	355-8	33	52	53	56	57	56	49	40
400-4	60	69	72	65	68	69	65	56	400-4	52	70	73	73	75	74	70	59
400-8	45	54	57	50	53	54	50	41	400-8	37	55	58	58	60	59	55	44
450-4	56	65	71	76	72	71	65	57	450-4	56	69	75	77	79	76	71	61
450-8	56	69	75	77	79	76	71	61	450-8	41	54	60	62	64	61	56	46
500-4	57	62	73	76	76	75	69	60	500-4	58	67	78	79	83	80	74	63
500-8	42	47	58	61	61	60	54	45	500-8	43	52	63	64	68	65	59	48
560-6	69	78	80	81	82	82	79	57	560-6	65	79	85	86	90	86	81	72
560-12	54	63	65	66	67	67	64	57	560-12	50	64	70	71	75	71	66	57

**Dimensions in mm**

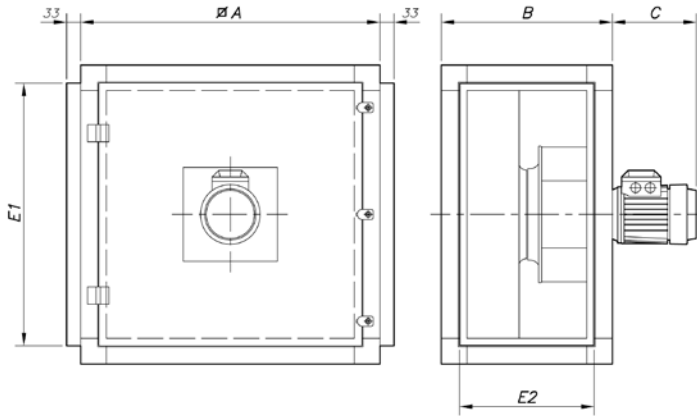

Model	ØA	B	C	E1	E2
CJEC-280	700	400	200	618	318
CJEC-315	700	400	200	618	318
CJEC-344	800	505	200	718	423
CJEC-400	800	505	225	718	423
CJEC-450	900	550	225	818	468
CJEC-500	900	550	260	818	468
CJEC-560	1000	700	290	918	618

**Characteristic curves**

Q = Airflow in m<sup>3</sup>/h, m<sup>3</sup>/s and cfm.

Pe = Static pressure in mm.w.c., Pa and inwg.

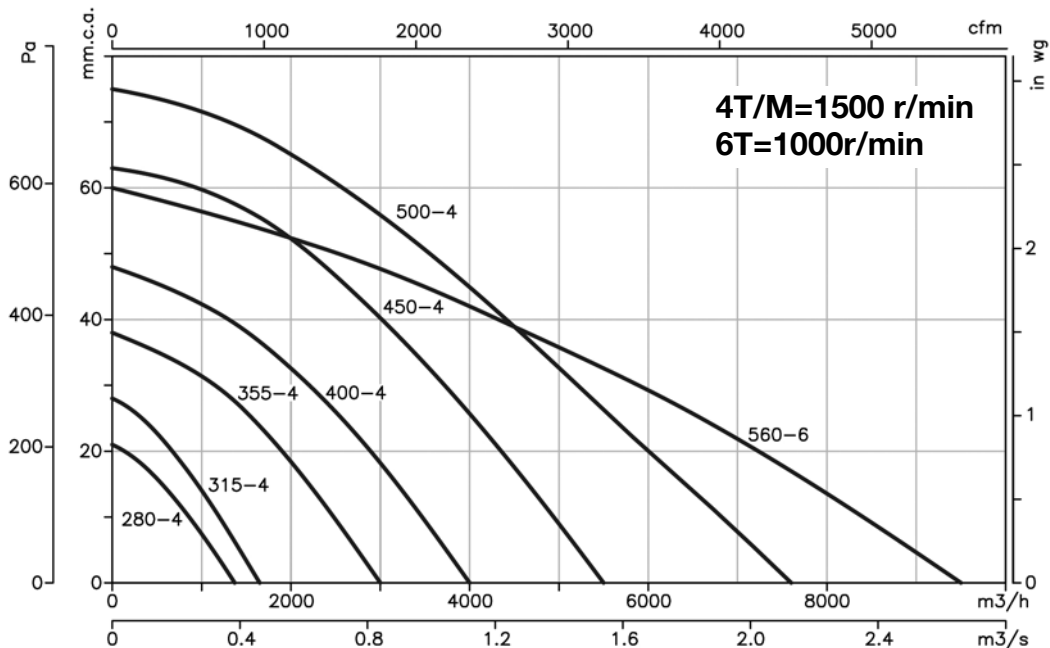

**Characteristic curves**

Q = Airflow in m<sup>3</sup>/h, m<sup>3</sup>/s and cfm.

Pe= Static pressure in mm.w.c., Pa and inwg.

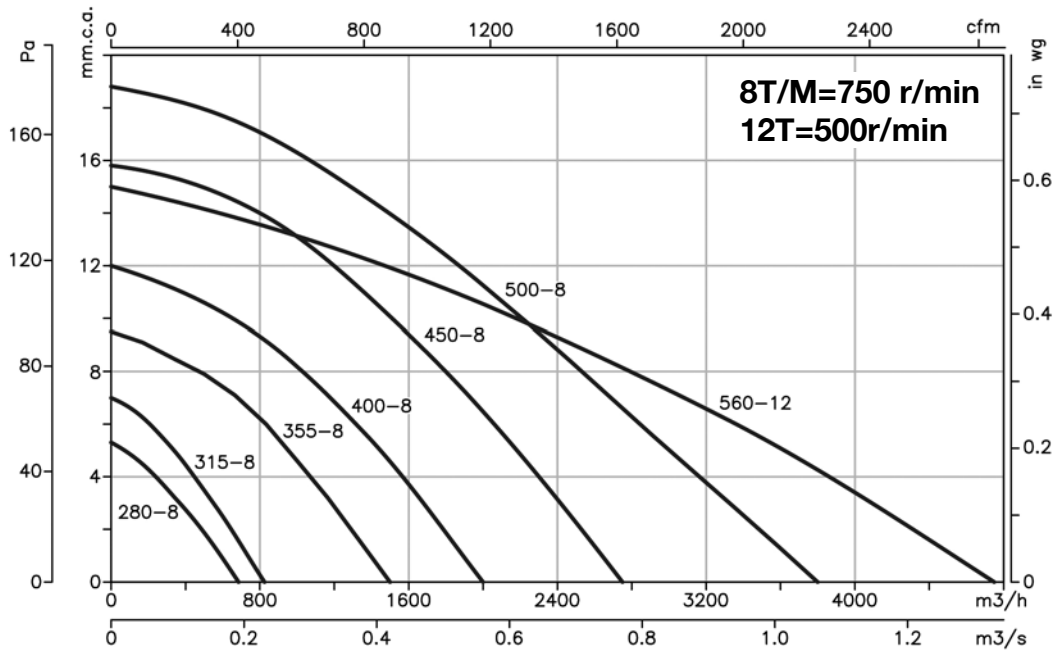

**CJEC installations**

Possibility of installing the CJEC series by changing the position of the inlet and outlet panels

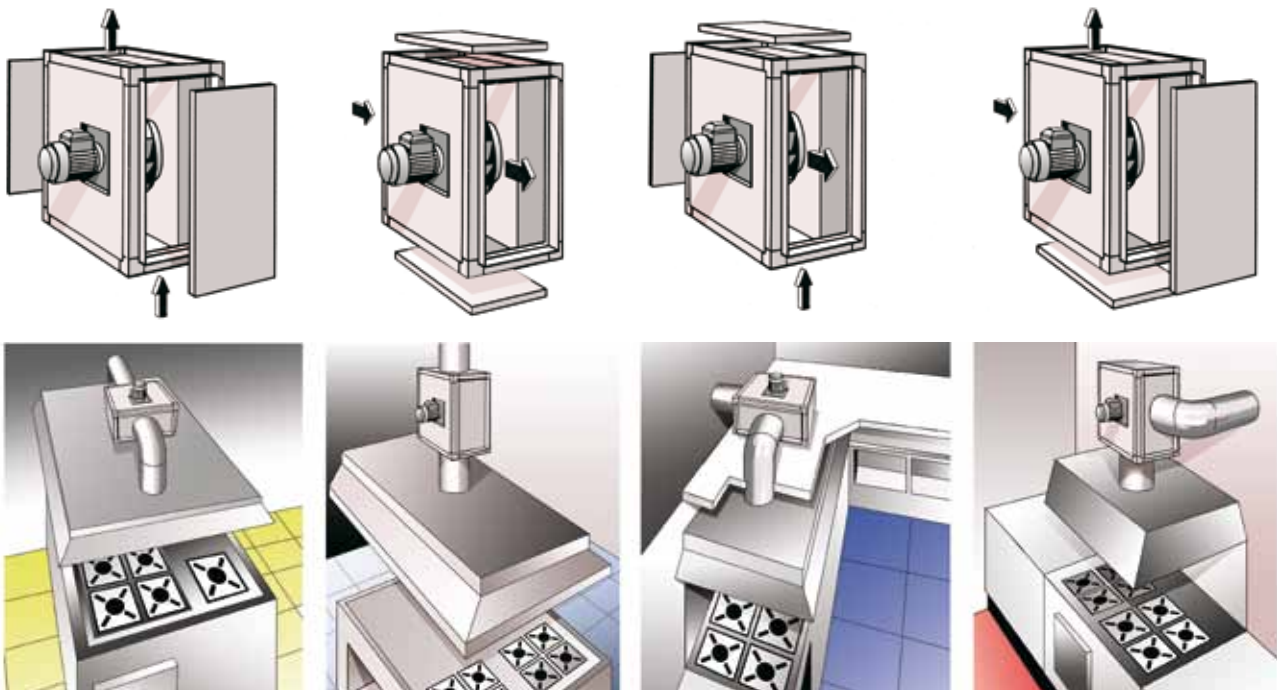

**Accessories**

See accessories section



# CHT CVT

## 400°C/2h centrifugal roof fans with horizontal or vertical outlet air

CHT: 400°C/2h centrifugal roof fans with horizontal outlet air, hood in aluminium

CVT: 400°C/2h centrifugal roof fans with vertical outlet air, hood in aluminium



CHT



CVT

### Fan:

- Galvanised sheet steel base plate.
- Impeller with backward-curved blades made from galvanised sheet steel
- Bird guard
- Aluminium rain deflector hood
- Approval according to Standard EN-12101-3-2002, certificate no.: 0370-CPD-0897

### Motor:

- Class F motors, with ball bearings and IP55 protection, except single-phase versions, IP54 protection, one- or two-speed depending on the model
- Single-phase 230V.-50Hz., and three-phase 230/400V.-50Hz.
- Max. temperature of air for transport: -25°C.+ 120°C.

### Finish:

- Anticorrosive galvanized sheet steel and aluminium

### On request:

- Special windings for different voltages,
- ATEX certification, Category 3



Brackets that aid mounting on the roof

### Order code

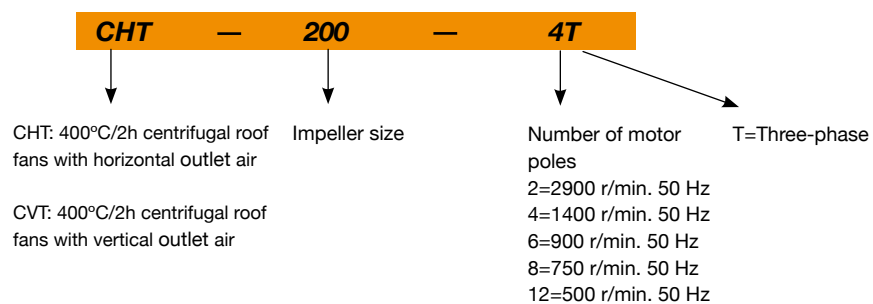

## Technical characteristics

Model	Speed (r/min)	Maximum admissible current (A)		Power installed (kW)	Airflow maximum (m³/h)	Sound level dB(A)		Approx. weight (Kg)
		230V	400V (A)			Inlet	Outlet	
CHT CVT 200-4T	1350	1.45	0.84	0.25	1450	37	43	25
CHT CVT 200-4M	1380	0.65		0.25	1450	37	43	25
CHT CVT 225-4T	1350	1.45	0.84	0.25	2100	41	47	25
CHT CVT 225-4M	1380	0.95		0.25	2100	41	47	25
CHT CVT 225-6T	900	1.51	0.87	0.25	1400	30	36	26
CHT CVT 225-6M	890	0.50		0.25	1400	30	36	26
CHT CVT 250-4T	1350	1.45	0.84	0.25	3100	45	50	34
CHT CVT 250-4M	1380	1.35		0.25	3100	45	50	34
CHT CVT 250-6T	900	1.51	0.87	0.25	2000	33	40	35
CHT CVT 250-6M	890	0.65		0.25	2000	33	40	35
CHT CVT 315-4T	1370	2.74	1.58	0.55	4950	48	54	39
CHT CVT 315-4/8T	1435 / 715		1.60 / 0.60	0.55 / 0.09	4950 / 2475	48 / 33	54 / 39	40
CHT CVT 315-4M	1380	3.30		0.55	4950	48	54	39
CHT CVT 315-6T	900	2.13	1.23	0.37	3200	37	43	39
CHT CVT 315-6M	910	0.95		0.37	3200	37	43	39
CHT CVT 400-4T	1380	3.34	1.93	0.75	7000	55	61	57
CHT CVT 400-4/8T	1425 / 710		2.30 / 0.90	0.75 / 0.12	7000 / 3500	55 / 40	61 / 46	58
CHT CVT 400-4M	1380	4.40		0.75	7000	55	61	57
CHT CVT 400-6T	900	2.13	1.23	0.37	4500	44	50	56
CHT CVT 400-6M	910	1.80		0.37	4500	44	50	56
CHT CVT 450-4T	1400	5.97	3.45	1.50	10200	59	64	66
CHT CVT 450-4/8T	1420 / 700		3.50 / 1.50	1.50 / 0.37	10200 / 5100	59 / 43	64 / 49	66
CHT CVT 450-6T	900	2.13	1.23	0.37	6900	47	54	59
CHT CVT 450-6/12T	930 / 450		1.60 / 0.65	0.55 / 0.09	6900 / 3450	47 / 32	54 / 39	63
CHT CVT 450-6M	910	2.00		0.37	6900	47	54	59
CHT CVT 500-6T	925	5.23	3.02	1.10	12000	51	57	103
CHT CVT 500-6/12T	950 / 470		3.00 / 1.15	1.10 / 0.18	12000 / 6000	51 / 36	57 / 42	110
CHT CVT 500-8T	680	3.21	1.85	0.55	8900	44	50	103
CHT CVT 560-6T	955	9.28	5.36	2.20	17300	54	61	126
CHT CVT 560-6/12T	940 / 470		5.60 / 2.20	2.20 / 0.37	17300 / 8650	54 / 39	61 / 46	120
CHT CVT 560-8T	710	5.54	3.20	1.10	12900	46	53	110
CHT CVT 630-6T	960	16.35	9.44	4.00	24700	58	64	166
CHT CVT 630-6/12T	970 / 480		11.00 / 4.00	4.00 / 0.65	24700 / 12350	58 / 43	64 / 49	161
CHT CVT 630-8T	710	7.45	4.30	1.50	18400	50	57	148

(1) The sound level values are measurements of pressure in dB(A) at a distance of 6 m and at 2/3 of the maximum airflow (2/3 Qmax.)

## Acoustic features

The specified values are determined according to free field measurements of pressure and sound levels in dB(A) at a distance of 6 m.

### Sound power Lw(A) spectrum in dB(A) via frequency band in Hz.

Values taken at the inlet with 2/3 of the maximum airflow (2/3Qmax).								Values taken at outlet with 2/3 of the maximum airflow (2/3Qmax).									
Model	63	125	250	500	1000	2000	4000	8000	Model	63	125	250	500	1000	2000	4000	8000
200	35	41	52	55	56	52	50	44	200	39	44	58	60	61	61	56	51
225-4	42	51	56	56	60	59	52	46	225-4	41	50	60	64	67	64	57	51
225-6	31	40	45	45	49	48	41	35	225-6	30	39	49	53	56	53	46	40
250-4	46	55	60	60	64	63	56	50	250-4	44	53	63	67	70	67	60	54
250-6	34	43	48	48	52	51	44	38	250-6	34	43	53	57	60	57	50	44
315-4	50	56	62	62	65	68	59	53	315-4	49	61	69	71	72	72	64	56
315-6	39	45	51	51	54	57	48	42	315-6	38	50	58	60	61	61	53	45
315-8	35	41	47	47	50	53	44	38	315-8	34	46	54	56	57	57	49	41
400-4	57	63	69	69	72	75	66	60	400-4	56	68	76	78	79	79	71	63
400-6	46	52	58	58	61	64	55	49	400-6	45	57	65	67	68	68	60	52
400-8	42	48	54	54	57	60	51	45	400-8	41	53	61	63	64	64	56	48
450-4	62	69	74	74	78	77	70	65	450-4	60	72	80	82	83	80	73	65
450-6	50	57	62	62	66	65	58	53	450-6	50	62	70	72	73	70	63	55
450-8	46	53	58	58	62	61	54	49	450-8	45	57	65	67	68	65	58	50
450-12	35	42	47	47	51	50	43	38	450-12	35	47	55	57	58	55	48	40
500-6	54	60	65	66	70	69	62	55	500-6	50	64	72	76	75	72	66	60
500-8	47	53	58	59	63	62	55	48	500-8	43	57	65	69	68	65	59	53
500-12	39	45	50	51	55	54	47	40	500-12	35	49	57	61	60	57	51	45
560-6	57	63	68	69	73	72	65	58	560-6	54	68	76	80	79	76	70	64
560-8	49	55	60	61	65	64	57	50	560-8	46	60	68	72	71	68	62	56
560-12	42	48	53	54	58	57	50	43	560-12	39	53	61	65	64	61	55	49
630-6	61	67	72	73	77	76	69	62	630-6	57	71	79	83	72	79	73	67
630-8	53	59	64	65	69	68	61	54	630-8	50	64	72	76	72	72	66	60
630-12	46	52	57	58	62	61	54	47	630-12	42	56	64	68	67	64	58	52

To obtain the Lwa sound power spectra in dB(A) at the inlet with the maximum airflow (Qmax), add the values in the following tables to the LpA sound pressure level given on the characteristic curves:

Frequency band in Hz							
63	125	250	500	1000	2000	4000	8000
2	9	15	15	18	18	11	5

## Dimensions in mm

### CHT Model

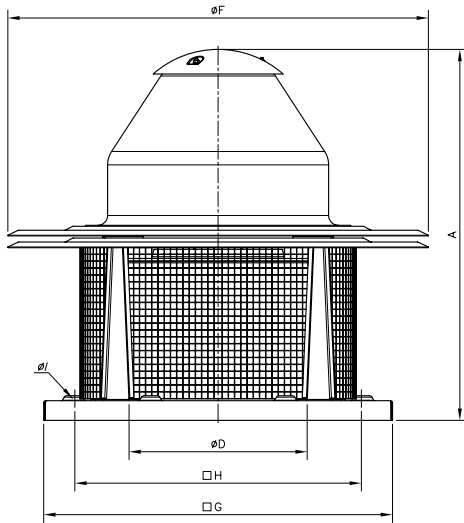

Model	A	øD*	øF	G	H	øI
CHT-200	552	250	570	450	360	12
CHT-225	570	250	570	450	360	12
CHT-250	632	355	726	560	450	12
CHT-315	682	355	726	560	450	12
CHT-400	755	500	856	710	590	12
CHT-450	770	500	856	710	590	12
CHT-500	846	630	1075	900	750	14
CHT-560	1035	710	1300	1100	900	14
CHT-630	1098	710	1300	1100	900	14

(\*) Recommended nominal diameter for duct.

### CVT Model

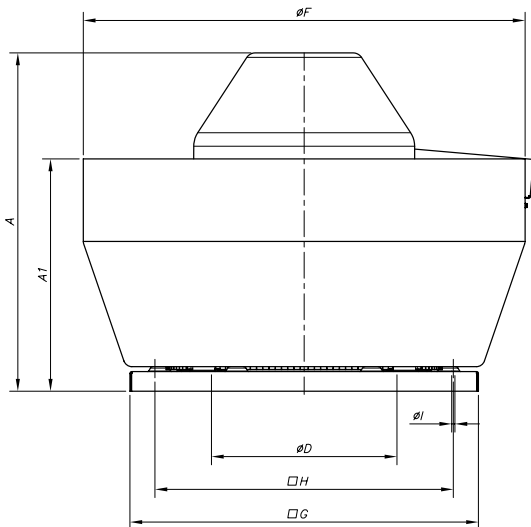

Model	A	A1	øD*	øF	G	H	øI
CVT-200	500	308	250	530	450	360	12
CVT-225	517	308	250	530	450	360	12
CVT-250	580	380	355	705	560	450	12
CVT-315	630	380	355	705	560	450	12
CVT-400	690	475	500	900	710	590	12
CVT-450	705	475	500	900	710	590	12
CVT-500	775	545	630	1100	900	750	14
CVT-560	956	676	710	1295	1100	900	14
CVT-630	1017	676	710	1295	1100	900	14

(\*) Recommended nominal diameter for duct.

Characteristic curves

Q = Airflow in m<sup>3</sup>/h, m<sup>3</sup>/s and cfm.  
Pe = Static pressure in mm.w.c., Pa and inwg.  
The Lp (dB(A)) sound levels given on the curves are free field pressure measurements at 6 metres at the inlet.

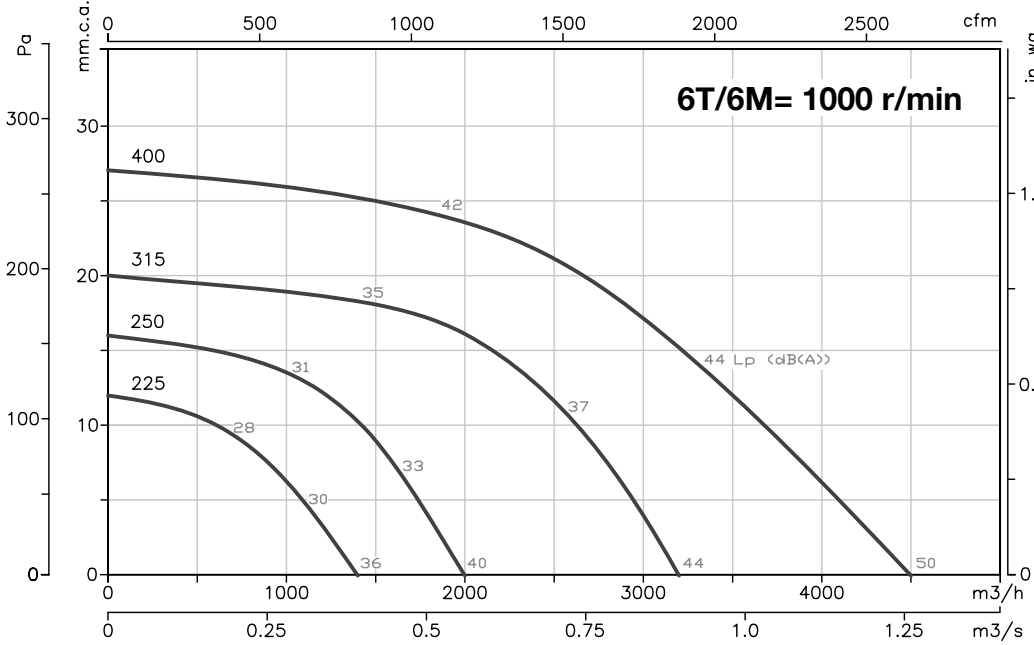
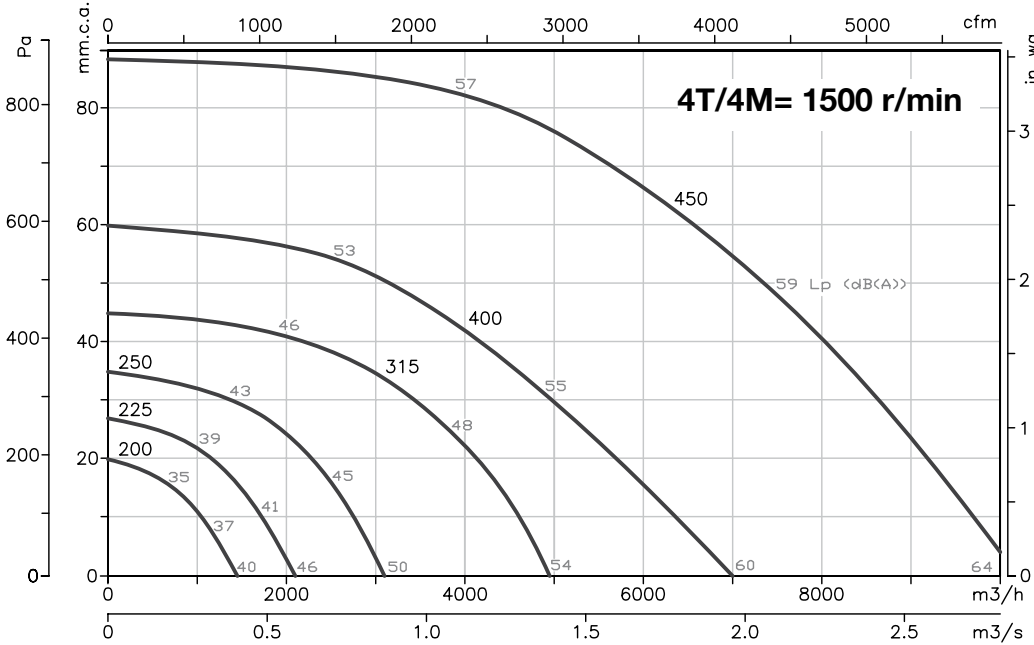

**Characteristic curves**

Q = Airflow in m<sup>3</sup>/h, m<sup>3</sup>/s and cfm.

Pe= Static pressure in mm.w.c., Pa and inwg.

The Lp (dB(A)) sound levels given on the curves are free field pressure measurements at 6 metres at the inlet.

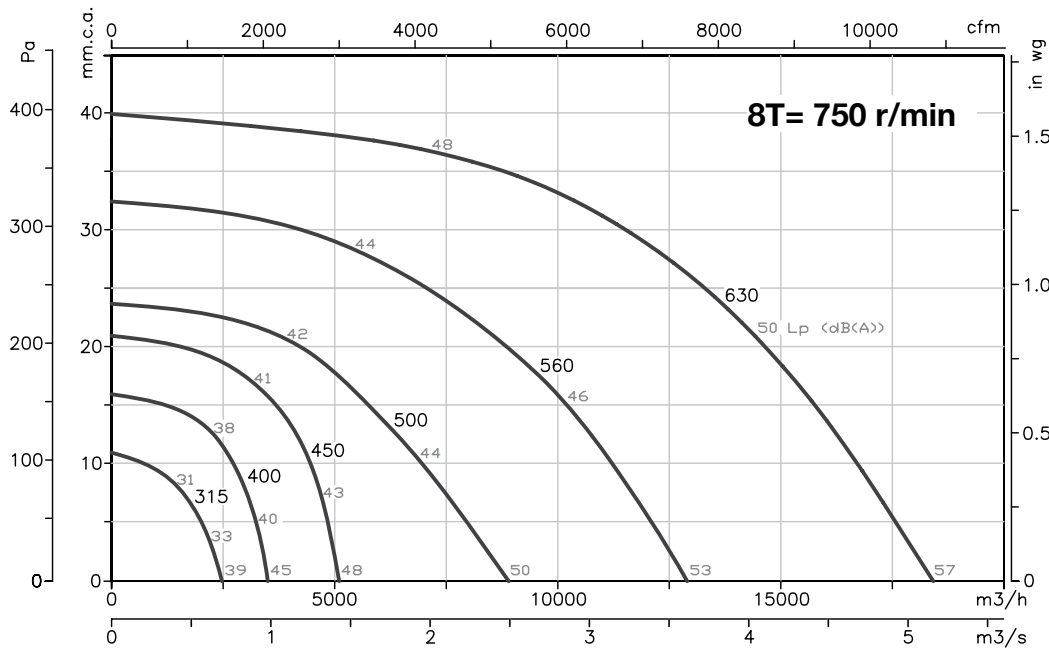
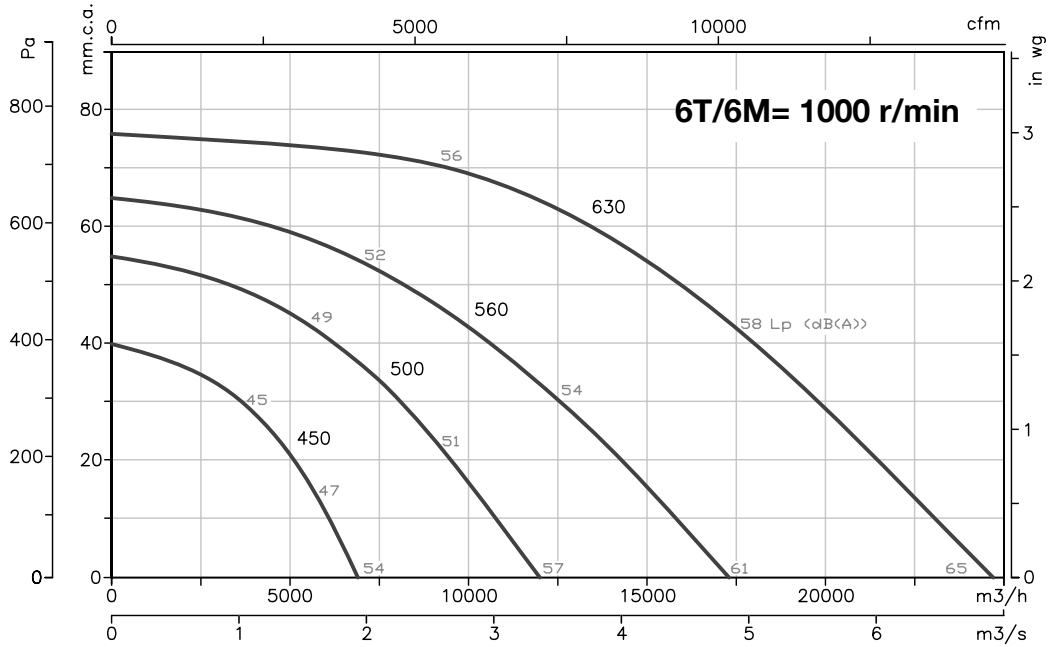

**Characteristic curves**

Q = Airflow in m<sup>3</sup>/h, m<sup>3</sup>/s and cfm.  
 Pe = Static pressure in mm.w.c., Pa and inwg.  
 The Lp (dB(A)) sound levels given on the curves are free field pressure measurements at 6 metres at the inlet.

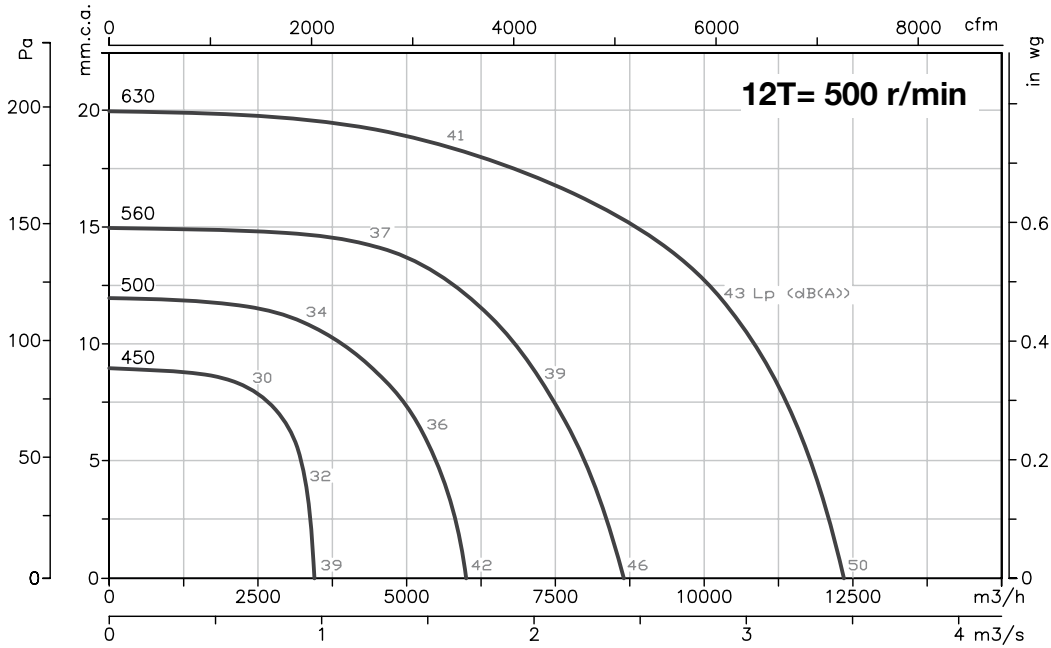

**Variation of sound pressure depending on distance**

The sound level may vary depending on the roof structure.

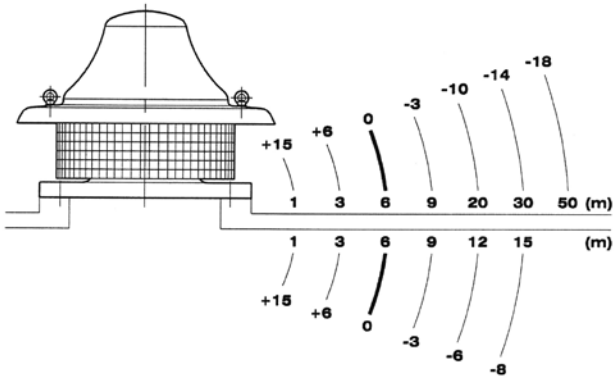

**Example of use**

Fans suitable for use in industrial kitchens.  
 For the correct application of the standard:  
 • C.T.E. Technical Building Code Basic SI Document for fire safety  
 Basic HS Document for health and safety

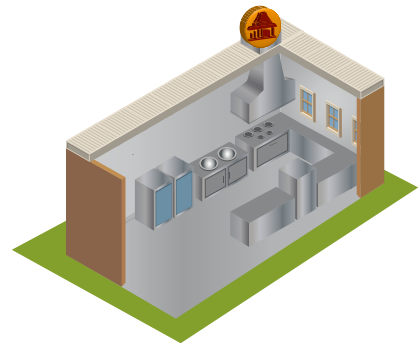

**Accessories**

See accessories section



# KIT SOBREPRESIÓN

**The system of pressurisation of staircases, escape routes or of confinement makes it possible to control the airflow automatically and to maintain a differential pressure of 50 Pa in a single stage, according to standard UNE EN 12101-6-2006.**

STAIRWELL KIT SOBREPRESIÓN  
For three-phase equipment



## STAIRWELL KIT SOBREPRESIÓN

- Stairwell overpressure kit made up of control panel (BOXPRES KIT) and outlet units (CJHCH or CJBD) , for the pressurisation of the stairwells and escape routes. It also available for single-phase equipment NEOLINEO AND CJBC.

## KIT SOBREPRESIÓN WITH RESERVE FAN

- Overpressure kit with reserve fan, made up of control panel (BOXPRES KIT II), which incorporates a system of automatic switching to keep the overpressure in the case of a stop by the main fan and TWIN or CJHCH/DUPLEX air outlet units with reserve fan.

STAIRWELL KIT SOBREPRESIÓN  
For single-phase equipment



## BOXPRES



- Easy to install
- Compact and self-sufficient solution
- Preventive maintenance
- Easy starting
- Safe and functional installation



- The proper operation of the pressurisation systems depends not only on correct design but also on the proper regulation carried out by the system with the result that it is of vital importance to have calibrated and highly-precise regulation elements which make it possible to have the two situations in the case of fire, in a rapid and stable manner.
- The BOXPRES control panel, apart from satisfying the most demanding requirements, simplifies the work of the installer to the greatest possible extent.

Includes:

- Frequency variator programmed to 50 Pa
- Differential pressure probe
- Magneto thermal
- Line LED and fault
- Check button

BOXPRES is a piece of equipment with all its interconnections made and tested

- Ready to work and carry out its duties on the pressure control of the installation.
- Possibility of checking the installation so as to prevent faults
- Only the power cable, the impulsion fan and the fire signal should be connected.

The panels for single-phase equipment include:

- Frequency voltage programmed to 50 Pa
- Differential pressure probe external to the equipment.

KIT SOBREPRESIÓN WITH  
RESERVE FAN



## Order code

**KIT SOBREPRESIÓN — 7.100**

Kit sobrepresión: Overpressure set for staircases  
Kit sobrepresión II: Overpressure set with reserve fan

Maximum  
Airflow

## Technical characteristics

Model	Power supply	Output	Outlet unit	Airflow (m³/h)	Irradiated sound level * dB(A)
KIT SOBREPRESION-1060-LED	230 Vac II	230 Vac II	NEOLINEO-200	1060	38
KIT SOBREPRESION-2300-LED	230 Vac II	230 Vac II	NEOLINEO-315	2300	47
KIT SOBREPRESION-2880-LED	230 Vac II	230 Vac II	CJBC-2828-6M 1/3	2880	61
KIT SOBREPRESION-7100-LED	230 Vac II	230 Vac III	CJHCH-45-4T-0,5	7100	55
KIT SOBREPRESION-7800-LED	230 Vac II	230 Vac III	CJBD-3333-6T-1,5	7800	55
KIT SOBREPRESION-12900-LED	230 Vac II	230 Vac III	CJHCH-56-4T-1	12900	60
KIT SOBREPRESION-17000-LED	230 Vac II	230 Vac III	CJHCH-63-4T-1,5	17000	61
KIT SOBREPRESION-7100-BOX	400 Vac III	400 Vac III	CJHCH-45-4T-0,5	7100	55
KIT SOBREPRESION-7800-BOX	400 Vac III	400 Vac III	CJBD-3333-6T-1,5	7800	55
KIT SOBREPRESION-12900-BOX	400 Vac III	400 Vac III	CJHCH-56-4T-1	12900	60
KIT SOBREPRESION-17000-BOX	400 Vac III	400 Vac III	CJHCH-63-4T-1,5	17000	61
KIT SOBREPRESION II-6240-BOX	400 Vac III	400 Vac III	TWIN-12/12-6T-1,5	6240	55
KIT SOBREPRESION II-9520-BOX	400 Vac III	400 Vac III	TWIN-15/15-6T-3	9520	54
KIT SOBREPRESION II-12900-BOX	400 Vac III	400 Vac III	CJHCH/DUPLEX-56-4T-1-H	12900	60
KIT SOBREPRESION II-17000-BOX	400 Vac III	400 Vac III	CJHCH/DUPLEX-63-4T-1,5-H	17000	61
SONDA TPDA SI-PRESIÓN c/DISPLAY					
SONDA TPDA 984M.523 P04					
SONDA TPDA 984M.523 P14 LED					
BOXPRES KIT-3A 230Vac	230 Vac II	230 Vac II			
BOXPRES KIT-10A 230Vac	230 Vac II	230 Vac II			
BOXPRES KIT-0,75KW 230Vac	230 Vac II	230 Vac III			
BOXPRES KIT-1,5KW 230Vac	230 Vac II	230 Vac III			
BOXPRES KIT-0,75KW 400Vac	400 Vac III	400 Vac III			
BOXPRES KIT-1,5KW 400Vac	400 Vac III	400 Vac III			
BOXPRES KIT-2,2KW 400Vac	400 Vac III	400 Vac III			
BOXPRES KIT II - 1,5KW 400Vac	400 Vac III	400 Vac III			
BOXPRES KIT II - 2,2KW 400Vac	400 Vac III	400 Vac III			

## Dimensions in mm

### CJHCH

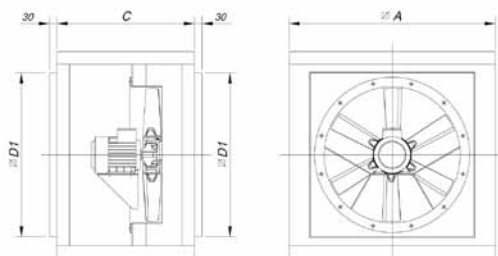

Model	∅A	C	∅D1
CJHCH-40/45/50	700	550	565
CJHCH-56/63	825	550	690

### CJBD

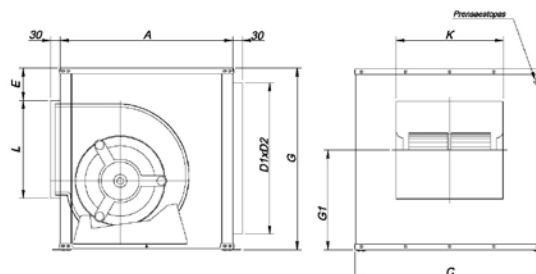

Model	Equiv. inches	A	B	C	E	D1xD2	G1	L	K
CJBD-3333	12/12	650	650	700	92	556X606	379	358	400

## Dimensions in mm

### TWIN

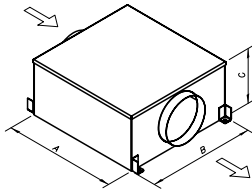

Model	A	B	C
TWIN-12/12	1103	1139	610
TWIN 15/15	1279	1639	698

### CJHCH/DUPLEX

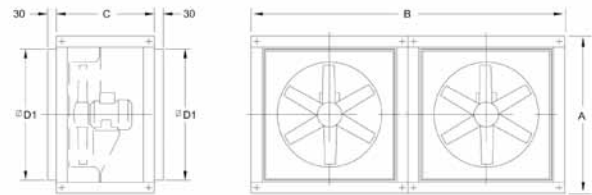

Model	∅A	B	C	∅D1
CJHCH/DUPLEX-56/63	825	1650	550	690

### NEOLINEO

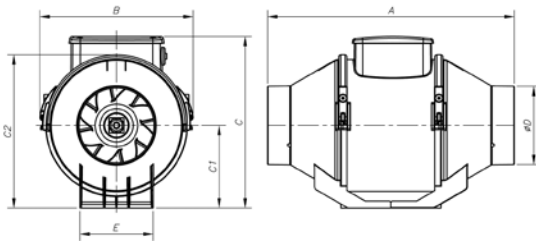

Model	A	B	C	C1	C2	∅D	E
NEOLINEO-200	300	234,5	260,5	125,5	235	196	140
NEOLINEO-315	448	361,5	392,5	188,5	359	312	220,5

### CJBC

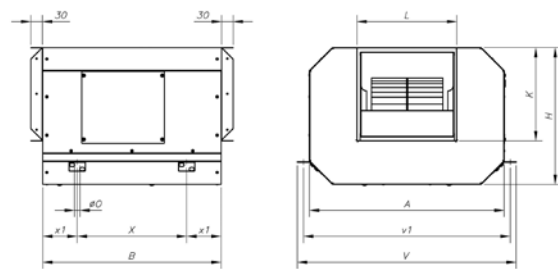

Model	A	B	H	K	L	∅O	V	v1	X	x1
CJBC-2828-6M-1/3	696	645	460	290	320	15	755	725	445	100

## BOXPRESS KIT SOBREPRESIÓN

### Technical characteristics and measurements

Model	Power kW	Power supply (V/Hz)	Output (V/Hz)	Output current (A)	Size	Measurements (L x W x D)
BOXPRES KIT-3A 230Vac	-	230 Vac II	230 Vac II	3	-	255 x 170 x 140 mm
BOXPRES KIT-10A 230Vac	-	230 Vac II	230 Vac II	10	-	255 x 170 x 140 mm
BOXPRES KIT-0,75kW 230Vac	0,75	230 V II / 50Hz	230 V III / 50Hz	4,3	1	270 x 270 x 170 mm
BOXPRES KIT-1,5kW 230Vac	1,5	230 V II / 50Hz	230 V III / 50Hz	7	1	270 x 270 x 170 mm
BOXPRES KIT-0,75KW 400Vac	0,75	400 V III / 50Hz	400 V III / 50Hz	2,2	1	270 x 270 x 170 mm
BOXPRES KIT-1,5KW 400Vac	1,5	400 V III / 50Hz	400 V III / 50Hz	4,1	1	270 x 270 x 170 mm
BOXPRES KIT-2,2KW 400Vac	2,2	400 V III / 50Hz	400 V III / 50Hz	5,8	2	360 x 360 x 205 mm

#### BOXPRES KIT-3A / KIT-10A

Connection of power and motor



#### Stuffing-box for cable input to equipment Size 1

M 20 x 1.5mm  
Connection of power and motor  
M 12 x 1.5mm  
Fire signal connection  
Pressure connection



#### Stuffing-box for cable input to equipment Size 2

M 20 x 1.5mm  
Connection of power and motor  
M 12 x 1.5mm  
Fire signal connection  
Pressure connection



## BOXPRES KIT SOBREPRESIÓN II

For equipment with reserve fan.

### Technical characteristics and measurements

Model	Power kW	Power supply (V/Hz)	Output (V/Hz)	Output current (A)	Size	Measurements (L x W x D)	
BOXPRES KIT II - 1,5KW	400Vac	1,5	400 V III / 50Hz	400 V III / 50Hz	4,1	1	270 x 270 x 170 mm
BOXPRES KIT II - 2,2KW	400Vac	2,2	400 V III / 50Hz	400 V III / 50Hz	5,4	2	360 x 360 x 205 mm

\* The two motors never operate simultaneously

#### Stuffing-box for cable input to equipment Size 1



#### Stuffing-box for cable input to equipment Size 2



### Example of use

Overpressure smoke control method; this system consists of pressurization by means of the injection of air in spaces which are used as escape routes for people in case of fire, such as stair wells, passageways, corridors, elevators, etc. Above all in densely occupied tall buildings. This method is based on smoke control by means of the speed of air and the artificial barrier which is created by excess air pressure over smoke, so that it cannot enter escape routes.

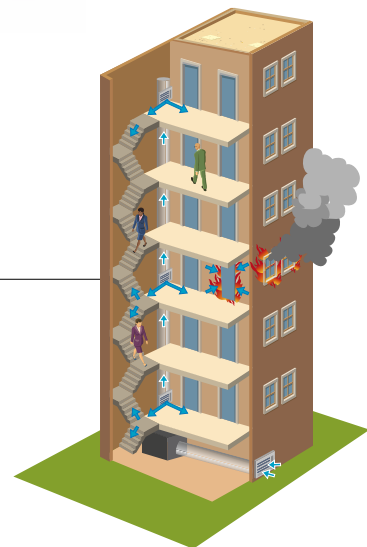

## CENTRAL CO

Monoxide detection centres for control of ventilation in car parks



In order to fulfil Royal Decree 2367/1985 and the Technical Building Code

The Carbon Monoxide detection centres have been designed for application in underground car parks, tunnels or other locations where dangerous concentrations of CO might accumulate.

The system consists of the installation of a centre of 1 to 3 modules of areas with indicator display and each module permits connection of up to 32 detectors connected with two wires, with a maximum distance to the final detector of 2 kilometres

The detectors may be distributed over 2000 metres in length and each detector covers a maximum of 200m<sup>2</sup> of area as is defined in the current regulations

Through the optional FM-TC500 card it is possible to control a series RFM or RFT speed regulator, with the aim of reducing the energy consumption and the acoustic level of the extractors.

These systems involve a significant energy saving.

- System certified according to standard 23300/84
- Certification LOM 09MOGA3054.
- Modular and extensible centre
- Up to 19000 m<sup>2</sup> of management
- Versions of 1, 2, and 3 modules of areas
- Indication of the concentration per area
- 2 outlets of relays of extraction per area.
- 1 outlet of relay of alarm per area.
- Up to 32 detectors per area.
- Connection of the detectors to 2 wires.
- Mode of operation for low consumption.
- Option of Control by Speed Varier to reduce energy consumption and the sound level.
- Option of remote control of the system and integration with systems of energy analysis.

Model	Application
FMC-C-501	Centre for 1 area
FMC-C-502	Centre for 2 areas
FMC-C-503	Centre for 3 areas
FM-M-509	Module for extension of area
FM-DP500	CO wall detector
FM-D500	CO ceiling detector
FM-TC500	Control card per varier



### CENTRES: Series FMC-C-501/502/503

- For 1, 2 or 3 areas depending on model
- Supplied voltage: 90 ~264VAC
- Power: 45 W
- Zone extension module FM-M-509

- Wiring of the area: 2 wires
- Maximum distance from the area line: 2 km. with 1.5 mm cable <sup>2</sup>
- Number of detectors per area 32 detectors



### CO Detector: Series FM-DP500/FM-D500

- Wall or ceiling mounted CO Detector according to model
- Technology: Electrochemical cell
- Useable lifetime 5 years
- Resolution: 1 ppm
- Reaction time: 10 seconds

- Storage temperature: -10°C to + 80°C
- Working area: 200m<sup>2</sup> limited by regulation
- IP Index from FM-D500: IP20
- IP Index from FM-DP500: IP54



### Control card per varier. Series FM-TC500

- Module with PWM outlets which makes it possible to attack the extraction motors by means of speed regulators (energy saving).
- Communications module to carry out actions of tele-maintenance and tele-management.
- Open communications protocol for integration with other systems.

# ACCESSORIES

<p><b>INT</b></p>  <p>On/Off safety switches in accordance with Standard LINE-EN 60204-1.</p> <p>168</p>	<p><b>IAT</b></p>  <p>On/Off safety switch for 200°C/2h and 400°C/2h</p> <p>168</p>	<p><b>CABLE BOX</b></p>  <p>Electrical cable and connection box kit 400°C/2h</p> <p>168</p>	<p><b>C2V</b></p>  <p>Switch for two-speed motors.</p> <p>168</p>	<p><b>RM</b></p>  <p>Electronic speed controllers</p> <p>168</p>
<p><b>AR</b></p>  <p>Soft starters for three-phase motors.</p> <p>169</p>	<p><b>RFT RFM</b></p>  <p>Frequency converters for 400V three-phase motors.</p> <p>169</p>	<p><b>ELECTRICAL PANELS</b></p>  <p>Electrical panels</p> <p>171</p>	<p><b>PL P P-400</b></p>  <p>Backdraught louvres, certified for 400°C/2h.</p> <p>172</p>	<p><b>R/THT</b></p>  <p>Protection guard for inlet of axial fans.</p> <p>172</p>
<p><b>RT</b></p>  <p>Protection guard for inlet or outlet of long-cased axial fans.</p> <p>172</p>	<p><b>RPA</b></p>  <p>Protection guard for inlet of centrifugal fans.</p> <p>172</p>	<p><b>B</b></p>  <p>Coupling flange for centrifugal fans.</p> <p>173</p>	<p><b>BTUB</b></p>  <p>Coupling flange for axial fans.</p> <p>173</p>	<p><b>BD</b></p>  <p>Double, elastic coupling flange for centrifugal fans.</p> <p>173</p>
<p><b>BAC</b></p>  <p>Double, elastic coupling flange for axial fans.</p> <p>174</p>	<p><b>BIC</b></p>  <p>Flange to change from rectangular to circular for centrifugal fans.</p> <p>174</p>	<p><b>PS</b></p>  <p>Support stands for long-cased fans</p> <p>174</p>	<p><b>MS</b></p>  <p>Support frame to allow mounting on-site.</p> <p>174</p>	<p><b>PA</b></p>  <p>Adaptation plate to mount accessories on roof fans.</p> <p>174</p>
<p><b>PT</b></p>  <p>Automatic-closing shutters to work in vertical position</p> <p>175</p>	<p><b>ACE-400</b></p>  <p>400°C/2h elastic coupling to absorb vibrations.</p> <p>175</p>	<p><b>REG</b></p>  <p>Record of regulation manual</p> <p>175</p>	<p><b>VIS</b></p>  <p>Outlet hood with protection guard.</p> <p>175</p>	<p><b>TEJ</b></p>  <p>Outside covers.</p> <p>176</p>
<p><b>CM</b></p>  <p>Motor cover for outside work.</p> <p>176</p>	<p><b>TAC</b></p>  <p>Circular coupling plate.</p> <p>176</p>	<p><b>S</b></p>  <p>Silencers to fit to inlet or outlet.</p> <p>176</p>	<p><b>CENTRAL CO</b></p>  <p>CO detection centres</p> <p>166</p>	<p><b>KITS SOBREPRESIÓN</b></p>  <p>162</p>



## INT

On/off safety switches in accordance with Standard UNE-EN 60204-1.

**Features:**

- Switches to install beside the fan, so that the mains current can be cut off before handling the fan.
- IP65 protection
- For three-phase or two-speed fans, use 6-pole switch
- For single-phase fans, use a 3-pole switch

Model	Current (A)	(kW)	Cable input (mm)	Model	Current (A)	(kW)	Cable input (mm)
INT-CA 10/3CA	20	5.5	19	INT-CA 10/6CA	20	5.5	19
INT-KG 10/3CA	20	5.5	23	INT-KG 10/6CA	20	5.5	23
INT-KG 20/3CA	25	7.5	29	INT-KG 20/6CA	25	7.5	29
INT-KG 32/3CA	32	11	29	INT-KG 32/6CA	32	11	29
INT-KG 41/3CA	40	15	37.5	INT-KG 41/6CA	40	15	37.5
INT-KG 64/3CA	63	22	37.5	INT-KG 64/6CA	63	22	37.5
INT-KG 80/3CA	80	30	37.5	INT-KG 80/6CA	80	30	37.5
INT-KG 100/3CA	100	37	37.5	INT-KG 100/6CA	100	37	37.5



## IAT

On/off safety switches for 400°C/2h and 200°C/2h in accordance with Standard UNE-EN 60204-1.

**Features:**

- 400°C/2h and 200°C/2h switches to be placed beside the fan, so that the mains current can be cut off before handling the fan.
- Protection IP-65 model 400°C/2h and IP-55 model 200°C/2h

Model	Current (A)	Model	Current (A)
IAT-400-20/3P	20	IAT-400-63/6P	63
IAT-400-32/3P	32	IAT-400-125/6P	125
IAT-400-63/3P	63	IAT-200/16	16
IAT-400-125/3P	125	IAT-200/32	32
IAT-400-20/6P	20	IAT-200/63	63
IAT-400-32/6P	32		



## CABLE BOX

Electrical cable and connection box kit 400°C/2h for external connections to the motor in fire-fighting installations

**Features:**

- Electrical six-wire cable and ground connection, with length of 1.5m and terminals at each end
- Cast aluminium terminal board
- Terminal Strip in ceramic material

- Kit certified jointly with the CJBTD extractor series, with certification Number 0370-CPD-0580

Model	Maximum power motor 3x400V (kW)
CABLE BOX-1-400	5.5
CABLE BOX-2-400	15.0



## C2V

Switch for two-speed motors

**Features:**

- 1-0-2 three-position switch to operate two-speed motors with Dahlander connection
- IP67 protection

Model	Current (A)	(kW)	Cable input (mm)
C2V-CG10 A441	20	5.5	20

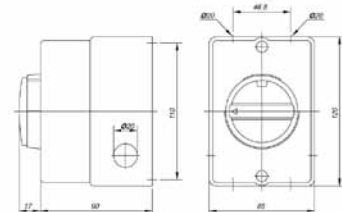

## RM

**Features:**

- Electronic speed controllers especially designed for fans with single-phase motors, in accordance with standard EN-60335
- Models RM-1, RM-2 and RM-3, IP54 protection. Models RM-00, RM-01 and RM-02, IP44 protection
- In accordance with Electromagnetic Compatibility Directives 92/31/EEC and 93/68/EEC and in accordance with Low Voltage Directive 73/23/EEC

- On/off switch.
- Minimum speed adjustment
- With EMC filters in accordance with standard EN-55014

Model	Input voltage	Protection	Maximum current (A)
RM-00	230 V-50/60 Hz	IP-44	0.5
RM-01	230 V-50/60 Hz	IP-44	1
RM-02	230 V-50/60 Hz	IP-44	2
RM-1	230 V-50/60 Hz	IP-54	3
RM-2	230 V-50/60 Hz	IP-54	5
RM-3	230 V-50/60 Hz	IP-54	10

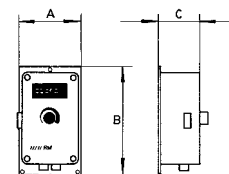

Model	A	B	C
RM-00	81	81	66
RM-01	81	81	66
RM-02	81	81	66
RM-1	80	145	80
RM-2	96	164	85
RM-3	96	164	85



## AR

Soft starters for three-phase motors.

Features:

- Especially designed to reduce the current peak caused during start-up of fans with three-phase motors.
- Power Voltage 400V + - 10% 50/60Hz
- Mounted in box for DIN-35 rail
- Possibility of adjusting the starting torque, acceleration time and deceleration time.

Model	AR-2	AR-4	AR-7.5	AR-10	AR-15	AR-20	AR-30
Supplied voltage	400 V ±10% 50/60 Hz						
Motor power in kW at 400 V	1.5	3	5.5	7.5	11	15	22
Minimum motor power	40% of the motor's nominal power			20% of the motor's nominal power			
External fuses (quick-action) in (A)	16	25	35	25	35/40	50	63
Nominal current in (A)	3.5	6,5	12	17	25	32	45
Adjustment range of start-up torque	From 0 to 80%						
Adjustment range of start-up time	From 0.5 to 12 s			From 0.5 to 10 s			
Braking torque	Level set at 70%						
Adjustment range of deceleration time	From 0.5 to 12 s			From 0.5 to 10 s			
Setup time	200 ms						
Working temperature	0°C....45°C						
Storage temperature	-25°C....75°C						
Protection level	IP20						
Environmental conditions	Overpressure category III, Pollution level 2						
Power reduced with max. temperature	1% for every 1°C increase in the maximum temperature						
Maximum height for mounting	Up to 1000 m						
Power reduced with max. height	0.5% for every 100 m over 1000 m.						
Humidity	93% maximum without condensation						
Maximum cycles per hour (3 x I nom, 10 sec)	90/h	60/h	30/h	60/h	40/h	30/h	20/h
Weight in kg	0.4			1.0			
Measurements	Width (W) mm	45			45		52.5
	Height (H) mm	73			173		178
	Depth (D) mm	122			152		158
Installation	Fixing A x B			On DIN guide rail			



## RFT RFM

Frequency converter for 400V three-phase motors.

Features:

- The RFT converter series are suitable to vary the speed, via voltage and frequency, of axial and centrifugal fans with 400V three-phase motors. Converter power supply: 400V three-phase. 50/60 Hz.
- In accordance with Electromagnetic Compatibility Directives 92/31/EEC and 93/68/EEC and in accordance with Low Voltage Directive 73/23/EEC

Features:

- The RFM converter series are suitable to vary the speed, via voltage and frequency, of axial and centrifugal fans with 230V three-phase motors. Converter power supply: 230V single-phase. 50/60 Hz.
- In accordance with Electromagnetic Compatibility Directives 92/31/EEC and 93/68/EEC and in accordance with Low Voltage Directive 73/23/EEC

Model	RFT-0.5	RFT-1	RFT-2	RFT-3	RFT-5.5	RFT-7.5	RFT-10	RFT-15	RFT-20	RFT-25	RFT-30
Motor (CV)	0.5	1	2	3	5.5	7.5	10	15	20	25	30
(kW)	0.37	0.75	1.5	2.2	4	5.5	7.5	11	15	18.5	22
Current (A)	1.25	2.5	4	6	9	12	16	24	30	39	45
kVA	0.95	1.9	3	4.5	6.9	9.1	12.2	19.1	23.9	31.1	35.9
Inlet	Three-phase										
Voltage (V)	3 x 380...480 V (-15% +10%)										
Frequency (Hz)	50 - 60 Hz (± 5%)										
Outlet	Three-phase										
Voltage (V)	3 x 380...480 V										
Frequency (Hz)	0....400 Hz						0...120 Hz				
Braking torque	20% (with external resistance: 100%, 150%)										
Braking unit	Incorporated in the equipment							Optional			
Size Width (W1) mm	70	70	100	140	140	180	180	200	250	250	304
Height (H1) mm	128	128	128	128	128	220	220	284	385	385	460
Depth (D1) mm	130	130	130	155	155	170	170	182	201	201	234
Weight (Kg)	0.76	0.77	1.12	1.84	1.89	3.66	3.66	6	12.5	13	20
Method of refrigeration	Forced air										

Model		RFM-0.5	RFM-1	RFM-2	RFM-3
Motor	(CV)	0.5	1	2	3
	(kW)	0.37	0.75	1.5	2.2
Current	(A)	2.5	2.5	4	6
kVA		0.95	1.9	3	4.5
Input		Single-phase			
Voltage	(V)	2 x 200 ÷ 230 V (±10%)			
Frequency	(Hz)	50 – 60 Hz (± 5%)			
Output		Three-phase			

Model		RFM-0.5	RFM-1	RFM-2	RFM-3
Voltage	(V)	3 x 200 ÷ 230 V			
Frequency	(Hz)	0 ÷ 400 Hz			
RFI Filter		Built in			
Size Width	(W1) mm	79	79	156	156
Height	(H1) mm	143	143	143	143
Depth	(D1) mm	143	143	143	143
Weight	(Kg)	0.95	0.97	1.94	2.00
Method of refrigeration		Forced air			

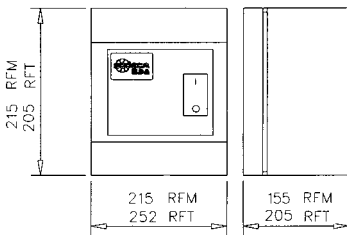

1. In general, all SODECA fans with a three-phase motor under normal operating conditions are suitable for working supplied with a static frequency converter (in accordance with IEC 60034-17). Nevertheless, some motors require special measures.

The maximum operating frequency or speed must never exceed that for which the fan has been designed. In applications with quadratic torques such as fans and pumps, when the speed varies the absorbed power is directly proportional to the cube of the rotating speed:  $P_{a_2} = P_{a_1} (n_2 / n_1)^3$

2. The insulation of motors coupled to fans is sufficient to work without restrictions with a frequency converter up to voltages of < 500 V. The use of sinusoidal filters at the converter output will help the motor to operate properly, reducing breakdowns and increasing the fan's service life.

It is recommended that, for motors of sizes > 225, they be ordered with special windings to work with a frequency converter.

3. The length of the wires running from the converter to the fan have a particular influence on voltage characteristics at the motor terminals. The definition of "long wires" will depend on the nominal value and the converter type. The manufacturer's technical documentation must be consulted.

4. EEx-d flame-resistant motors must be ordered for operation using a frequency converter. The motor manufacturer will request information about the application via a questionnaire in order to establish the working parameters. These motors must also be fitted with PTC probes.

5. EEx-e increased safety motors cannot be operated with a frequency converter (a joint motor-converter certification would be required for this).



## KME - 10K

External control kit for On/Off and velocity control for RFM and RFT frequency converters

Features:

- On/Off by button
- Display by means of LED of the position of On or Off
- Memory of the latest position for speed regulation

- Possibility of installation on the surface or built-in



## GMP

Electrical starter panel and protection of fans with three-phase motor, with On/Off buttons

Features:

- On/Off by button
- Incorporates fully-cabled contactor and adjustable thermal relay for protection of the motor
- The Off button is used to reset the thermal relay, in case it should go off due to overload
- For assembly on the surface, IP-55 protection

For fan with three-phase motor 230V

Model	Current of regulation (A)	Power motor 3x230V (kW)
GMP-0,2-0,33/230	1.2-1.8	0.25
GMP-02-0,75/230	1.8-2.8	0.37 / 0.55
GMP-02-1/230	2.8-4	0.75
GMP-02-1,5/230	4-6.3	1.10
GMP-02-2/230	5.6-8	1.50
GMP-04-3/230	7-10	2.20
GMP-04-4/230	8-12.5	3.00
GMP-04-5,5/230	11-17	4.00
GMP-04-7,5/230	15-23	5.50
GMP-04-10/230	22-32	7.50
GMP-06-12,5/230	25-40	9.20
GMP-06-15/230	25-40	11.00

For fan with three-phase motor 400V

Model	Current of regulation (A)	Power motor 3x400V (kW)
GMP-0,2-0,33/400	0.56-0.8	0.25
GMP-02-0,5/400	0.8-1.2	0.37
GMP-02-0,75/400	1.2-1.8	0.55
GMP-02-1,5/400	1.8-2.8	1.10
GMP-02-2/400	2.8-4	1.50
GMP-02-3/400	4-3	2.20
GMP-02-4/400	5.6-8	3.00
GMP-04-5,5/400	7-10	4.00
GMP-04-7,5/400	8-12.5	5.50
GMP-04-10/400	11-17	7.50
GMP-06-12,5/400	15-23	9.20
GMP-06-15/400	15-23	11.00
GMP-06-20/400	22-32	15.00
GMP-06-25/400	25-40	18.50



## GMM Electrical starter panel and protection from overload and short-circuits of fans with three-phase motor, with rotary controls

### Features:

- On/Off by means of a rotary control with the possibility of blocking with three locks
- Incorporates adjustable thermal relay for protection from overload and short-circuit
- For assembly on the surface, IP-55 protection

For fan with three-phase motor 400V

Model	Current of regulation (A)	Power motor 3x400V (kW)
GMM-01-1/400	1.6-2.5	0.75
GMM-01-2/400	2.5-4	1.10 1.50
GMM-01-3/400	4-6.3	2.20
GMM-01-5,5/400	6.3-10	3.00 4.00
GMM-01-7,5/400	10-16	5.50
GMM-01-10/400	16-20	7.50
GMM-01-15/400	20-25	11.00
GMM-01-20/400	25-32	15.00



## AET Electrical starter panel, star / triangle, and protection of fans with three-phase motor, with On/Off buttons

### Features:

- On/Off by button
- Display of condition by means of luminous pilot lights
- Incorporates adjustable thermal relay for protection of the motor

- Fully cabled
- Metal box for assembly on the surface, IP-65 protection

For fan with three-phase motor 230V/400V. Power supply 3x230V

Model	Current regulation of thermal relay (A)	Power motor 3x230/400V (kW)
AET-01-3/230	4-6.3	2.2
AET-01-4/230	5-8	3.0
AET-01-5,5/230	7-10	4.0
AET-01-7,5/230	12-18	5.5
AET-01-10/230	12-18	7.5
AET-01-15/230	18-26	11.0
AET-01-20/230	24-36	15.0
AET-01-25/230	28-40	18.5
AET-02-30/230	34-50	22.0
AET-02-40/230	45-65	30.0
AET-02-50/230	63-85	37.0

For fan with three-phase motor 400V/690V. Power 3x400V+N

Model	Current regulation of thermal relay (A)	Power motor 3x400/690V (kW)
AET-01-5,5/400	4-6,3	4
AET-01-7,5/400	5-8	5,5
AET-01-10/400	7-10	7,5
AET-01-15/400	12-18	11
AET-01-20/400	12-18	15
AET-02-30/400	18-26	18,5/22,0
AET-02-40/400	28-40	30
AET-02-50/400	34-50	37
AET-02-60/400	45-65	45
AET-02-75/400	45-65	55



## AD Electrical starter panel and protection of fans with three-phase motor, with two DAHLANDER speeds

### Features:

- Switch for selecting speed (1-0-2), Low-Off-High.
- Display of condition by means of luminous pilot lights
- Incorporates adjustable thermal relay for protection of the motor
- Fully cabled
- Metal plate for assembly on the surface, IP-65 protection

For fan with three-phase 400V Dahlander motor. Power 3x400V+N

Model	Current regulation of thermal relay	
	High speed (A)	Low speed (A)
AD-01-2,5-1/400	1,6-2,5	0,63-1
AD-01-4-1,6/400	2,5-4	1-1,6
AD-01-4-2,5/400	2,5-4	1,6-2,5
AD-01-6-2,5/400	4-6	1,6-2,5
AD-01-9-2,5/400	6-9	1,6-2,5
AD-01-9-4/400	6-9	2,5-4
AD-02-13-4/400	9-13	2,5-4
AD-02-18-6/400	12-18	4-6
AD-02-18-9/400	12-18	6-9
AD-02-26-9/400	18-26	6-9
AD-02-36-9/400	24-36	6-9
AD-02-36-13/400	24-36	9-13
AD-02-40-18/400	28-40	12-18



## PL Plastic backdraught louvres.

### Features:

- The backdraught louvre is adapted directly to the wall where the fan is mounted.
- Opening through overpressure due to airflow
- Closed when the fan is on standby
- Made from plastic
- Maximum recommended speed 12m/sec for models 80, 90 and 100

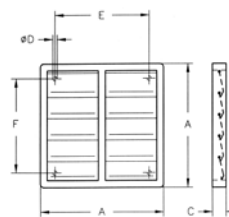

Model	Measurements				
	A	C	ØD	E	F
PL-20	240	28	5.2	193	167
PL-25	294	26	5	232	232
PL-31	347	26	5	276	276
PL-35	397	26	5	310	310
PL-40	459	26	5	364	364
PL-45	501	26	5	395	395
PL-50	549	31	5	445	445
PL-56	605	28	5	522	522
PL-63	696	31	5	626	626
PL-71	760	40	5	692	692
PL-80	840	40	5	772	772
PL-90	940	40	5	872	87
PL-100	1040	40	5	972	972



## P Aluminium backdraught louver

Features:

- The backdraught louver is adapted directly to the wall where the fan is mounted.
- Opening through excess pressure due to airflow
- Closed when the fan is on standby
- Aluminium sheet construction
- Maximum recommended speed 18m/sec for models 90 and 100

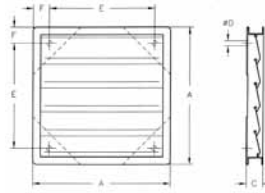

Model	Measurements				
	A	C	ØD	E	F
P-25	290	51	6	187	51.5
P-35	400	81	6	266	67
P-45	500	51	6	347	76.5
P-56	600	51	6	447	76.5
P-63	715	72	6	535	90
P-71	780	72	6	605	87.5
P-80	875	72	6	675	100
P-90	970	72	6	755	107.5
P-100	1070	72	6	850	110



## P-400 Backdraught louver, certified for 400°C/2h.



Features:

- Supplied mounted in the box with appropriate adapter
- Standardisation in accordance with standard EN-12101-3- 2002, certificate no.: 0370-CPD-0312
- Frame made from sheet steel and slats from aluminium sheet.
- Can be used for other 400°C/2h applications

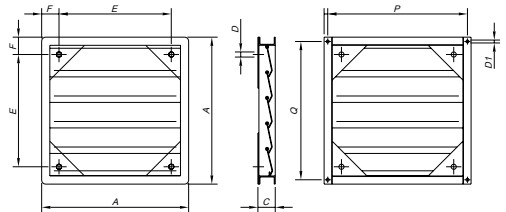

Model	A	C	ØD	E	F	P	Q	D1
P-400-56	645	51	6	492	76.5	595	595	10
P-400-63	760	72	6	580	90	720	720	10
P-400-80	915	72	6	715	100	880	880	10
P-400-100	1115	72	6	895	100	1080	1080	10



## R/THT Protection guard for inlet of axial fans.

Features:

- Protects against contact with the impeller and prevents objects from entering, in accordance with standard UNE-100250
- Manufactured with electro-soldered wire

Model	Applies to models
R-THT-40	THT-40
R-THT-45	THT-45
R-THT-50	THT-50
R-THT-56	THT-56 (Motors size 80/90)
R-THT-56-1	THT-56 (Motors size 100/112)
R-THT-63	THT-63 (Motors size 80/90)
R-THT-63-1	THT-63 (Motors size 100/112)
R-THT-63-2	THT-63 (Motors size 132)
R-THT-63-3	THT-63 (Motors size 160)
R-THT-71	THT-71 (Motors size 80/90)
R-THT-71-1	THT-71 (Motors size 100/112)
R-THT-80	THT-80 (Motors size 90/100)
R-THT-80-1	THT-80 (Motors size 112)
R-THT-80-2	THT-80 (Motors size 132)
R-THT-90	THT-90 (Motors size 90)
R-THT-90-1	THT-90 (Motors size 100/112)
R-THT-90-2	THT-90 (Motors size 132)

Model	Applies to models
R-THT-90-3	THT-90 (Motors size 160)
R-THT-100	THT-100 (Motors size 112)
R-THT-100-1	THT-100 (Motors size 132)
R-THT-100-2	THT-100 (Motors size 160)
R-THT-125	THT-125 (Motors size 132)
R-THT-125-1	THT-125 (Motors size 160)
R-THT-125-2	THT-125 (Motors size 180)
R-THT-125-3	THT-125 (Motors size 200)
R-THT-125-4	THT-125 (Motors size 225/250)
R-THT-140	THT-140 (Motors size 132/180)
R-THT-140-1	THT-140 (Motors size 160/200)
R-THT-140-2	THT-140 (Motors size .225/250)
R-THT-160	THT-160 (Motors size 132/180)
R-THT-160-1	THT-160 (Motors size 160/200)
R-THT-160-2	THT-160 (Motors size .225/250)
R-THT-160-3	THT-160 (Motors size 280)

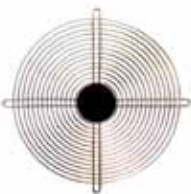

## RT Protection guard for inlet or outlet of long-cased axial fans.

Features:

- Protects against contact with the impeller and prevents objects from entering, in accordance with standard UNE-100250
- Manufactured with electro-soldered wire

Applies to models		Applies to models	
Model	THT	Model	THT
RT-25	-	RT-63	63
RT-31/B	-	RT-71	71
RT-31	-	RT-80	80
RT-35	-	RT-90	90
RT-40	40	RT-100	100
RT-45	45	RT-125	125
RT-50	50	RT-125/CC	125
RT-56	56		



## RPA Protection guard for inlet of centrifugal fans.

Features:

- Protects against contact with the impeller and prevents objects from entering, in accordance with standard UNE-100250
- Made from sheet steel.

Applies to models			Applies to models		
Model	CTMP TCMP	TCR TCR/R	Model	CTMP TCMP	TCR TCR/R
RPA-25	820	-	RPA-47	1640	1240
RPA-28	922	-	RPA-52	1845	1445
RPA-31	1025	-	RPA-60	2050	1650
RPA-35	1128	-	RPA-66	-	1856
RPA-38	1231	-	RPA-73	-	2063
RPA-42	1435	-	RPA-81	-	2271



## B Coupling flange for centrifugal fans.

- Features:
- Adapted to inlet and outlet.
  - Aids installation on duct

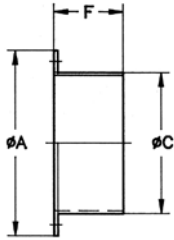

Model	A	C	F	Model	A	C	F	Model	A	C	F	Model	A	C	F
B-52-E	100	52	67	B-224	280	224	60	B-355/2	430	355	80	B-500/5	590	500	80
B-63	110	63	60	B-250/1	310	250	80	B-355/3	430	355	80	B-560/1	650	560	80
B-80	150	80	60	B-250/2	310	250	80	B-355/4	430	355	80	B-560/2	650	560	80
B-80-E	150	80	60	B-250/3	310	250	80	B-400/1	480	400	80	B-560/3	650	560	80
B-100	150	100	60	B-250/4	310	250	80	B-400/2	480	400	80	B-630/1	720	630	80
B-100-E	170	100	60	B-250/5	310	250	80	B-400/3	480	400	80	B-630/2	720	630	80
B-112	160	112	60	B-280/1	350	280	80	B-400/4	480	400	80	B-630/3	720	630	80
B-125	180	125	60	B-280/2	350	280	80	B-450/1	530	450	80	B-630/4	720	630	80
B-140	190	140	60	B-280/3	350	280	80	B-450/2	530	450	80	B-710/1	800	710	80
B-150	210	150	60	B-315/1	350	315	80	B-450/3	530	450	80	B-710/2	800	710	80
B-160	220	160	60	B-315/2	380	315	80	B-500/1	590	500	80	B-710/3	800	710	80
B-160/1	220	160	60	B-315/3	380	315	80	B-500/2	590	500	80	B-800	890	800	100
B-180	240	180	60	B-315/4	380	315	80	B-500/3	590	500	80	B-900/1	1000	900	100
B-200	260	200	60	B-355/1	430	355	80	B-500/4	590	500	80	B-1000/1	1100	1000	100

### Applies to models

	CVT CHT	CTMP TCMP	TCR TCR/R
B-112	-	512	-
B-140	-	514	-
B-160	-	616	-
B-180	-	718	-
B-200	-	620/820	-
B-224	-	922	-
B-250/3	200/225	1025	-

### Applies to models

	CVT CHT	CTMP TCMP	TCR TCR/R
B-280/2	-	1128	-
B-315/3	-	-	1031
B-315/4	-	1231	-
B-355/1	-	-	1135
B-355/3	250/315	1435	-
B-400/1	-	1640	-
B-400/2	-	-	1240

### Applies to models

	CVT CHT	CTMP TCMP	TCR TCR/R
B-450/1	-	1845	-
B-450/2	-	-	1445
B-500/1	-	2050	-
B-500/2	-	-	1650
B-500/4	400/450	-	-
B-560/2	-	-	1856
B-630/2	-	-	2063

### Applies to models

	CVT CHT	CTMP TCMP	TCR TCR/R
B-630/3	500	2563	-
B-710/1	-	-	2271
B-710/2	560/630	-	-
B-800	-	-	2380
B-900/1	-	-	2590
B-1000/1	-	-	28100



## BTUB

### Coupling flange for axial fans

- Features:
- Adapted to inlet and outlet.
  - Aids installation on duct

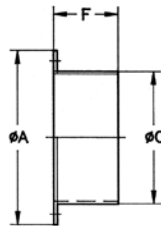

	C	A	F		C	A	F
BTUB-250	250	310	80	BTUB-630	630	720	80
BTUB-280	280	350	80	BTUB-710	710	800	80
BTUB-315	315	380	80	BTUB-800	800	890	100
BTUB-355	355	430	80	BTUB-900	900	1000	100
BTUB-400	400	480	80	BTUB-1000	1000	1100	100
BTUB-450	450	530	80	BTUB-1250	1250	1365	100
BTUB-500	500	590	80	BTUB-1400	1400	1520	100
BTUB-560	560	650	80	BTUB-1600	1600	1720	100



## BD

### Dual coupling flange for centrifugal fans.

- Features:
- Adapted to the inlet
  - Aids installation on duct with flange

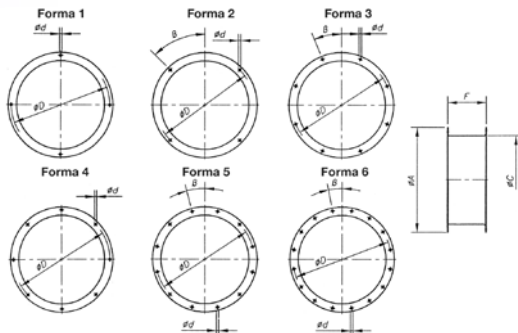

	ØA	ØC	ØD	Ød	F	β	Form	CTMP TCMP	TCR TCR/R
BD-200	260	200	225	7	80	15°	2	820	
BD-224	280	224	254	7	80	-	1	922	
BD-250/1	310	250	280	10	80	45°	2	1025	
BD-280	350	280	320	10	100	-	4	1128	
BD-315/3	390	315	355	10	100	22°30'	3	1231	
BD-355/3	430	355	395	10	100	22°30'	3	1435	
BD-400/1	480	400	450	12	100	22°30'	3	1640	
BD-400/2	480	400	450	12	100	22°30'	3		1240
BD-450/1	530	450	500	12	100	22°30'	3	2050	
BD-450/2	530	450	500	12	100	22°30'	3		1445
BD-500/2	590	500	560	12	100	15°	5		1650
BD-560	650	560	620	12	120	15°	5		1856
BD-630/2	720	630	690	12	120	15°	5		2063
BD-710	800	710	770	12	120	11°15'	6		2271



## BAC

Double, elastic coupling flange for axial fans

Features:

- Adapted to inlet and outlet
- Aids installation on duct with flange
- Prevents transmission of vibrations

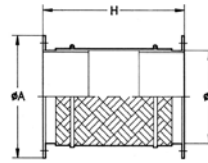

	ØD*	ØA*	H	CVT/CHT	THT
BAC-250	250	310	340	200/225	-
BAC-355	355	430	340	250/315	-
BAC-400	400	480	340	-	40
BAC-450	450	530	340	-	45
BAC-500	500	590	340	400/450	50
BAC-560	560	650	340	-	56
BAC-630	630	720	340	500	63
BAC-710	710	800	340	560/630	71
BAC-800	800	890	340	-	80
BAC-900	900	1000	340	-	90
BAC-1000	1000	1100	340	-	100
BAC-1250	1250	1365	340	-	125

\*Nominal diameter for pipe.



## BIC

Flange conversion from rectangular to circular for centrifugal fans.

Features:

- Adapted to the outlet
- Aids installation on circular duct

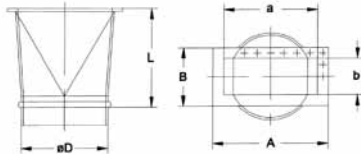

	L	D	a	b	A	B	Applies to models
BIC-820	300	200	160	130	213	184	TCMP-820
BIC-922	300	224	216	140	282	204	CTMP/TCMP-922
BIC-1025	300	250	250	165	314	229	CTMP/TCMP-1025
BIC-1128	300	280	300	180	364	244	CTMP/TCMP-1128
BIC-1231	300	315	320	200	384	266	CTMP/TCMP-1231
BIC-1435	300	355	280	228	344	294	CTMP/TCMP-1435
BIC-1640	300	400	320	250	404	336	CTMP/TCMP-1640
BIC-1845	450	450	360	284	444	370	CTMP/TCMP-1845
BIC-2050	450	500	450	315	545	412	CTMP/TCMP-2050
BIC-2563	450	630	600	410	706	512	TCMP-2563



## PS

Support stands for long-cased fans.

Features:

- When fixed to the flange, it allows the fan to be fixed to flat surfaces.

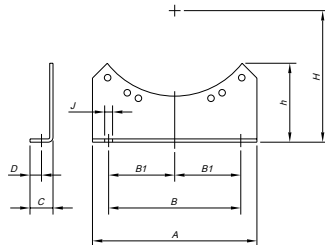

	A	B	B1	C	D	h	H	ØJ	THT
PS-35/40	240	200	-	30	13	60	255,5	10	40
PS-45/50	450	400	200	35	14,5	125	278	12	45
PS-45/50	450	400	200	35	14,5	125	305	12	50
PS-56/63	520	430	215	40	17	155	338	12	56
PS-56/63	520	430	215	40	17	155	385,5	12	63
PS-71	490	450	225	50	21	150	445	13	71
PS-80	600	560	280	50	21	150	490	13	80
PS-90	620	560	280	60	28	175	547,5	18	90
PS-100	680	560	280	60	28	185	597,5	18	100
PS-125	1000	900	300	60	28	285	726,5	18	125

Applies to the models



## MS

Support frame to facilitate mounting on-site.

Features:

- Used to facilitate on-site mounting of fans in ducts.

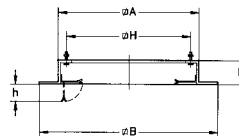

	ØA	ØB	E	ØH	h	Applies to the models
MS-443	443	615	60	360	70	200/225
MS-553	553	725	60	450	70	250/315
MS-701	701	875	60	590	90	400/450
MS-891	891	1065	60	750	90	500
MS-1086	1086	1260	60	850	90	560/630



## PA

Adaptation plate to mount accessories on roof fans.

Features:

- Used to mount PT, B, BTUB, BAC accessories. Allows fan to be separated from its base without dismantling accessories.

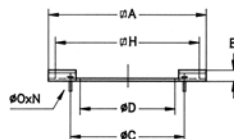

	ØA	ØJ	ØD	E	ØH	ØO	N	Applies to the models
PA-440/250	440	280	249	20	360	M.6	4X90°	220/225
PA-550	550	395	354	20	450	M.6	8X45°	250/315
PA-700/500	700	560	499	20	590	M.10	12X30°	400/450
PA-890/630	890	690	629	20	750	M.10	12X30°	500
PA-1085	1085	770	709	20	850	M.10	16X22°30'	560/630



## PT Automatic-closing shutters to work in vertical position

### Features:

- Automatic-closing circular shutters to be installed on inlet of roof fans.
- Use of PA adaptor plate recommended for assembly.

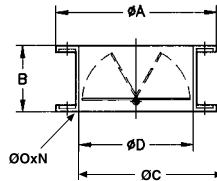

Applies to the models

	ØA	B	ØC	ØD*	ØØxN	CVT/CHT
PT-250	310	150	280	250	10 4X90*	200/225
PT-355	435	200	395	355	10 8X45*	250/315
PT-500	600	280	560	500	12 12X30*	400/450
PT-630	730	355	690	630	12 12X30*	500
PT-710	810	400	770	710	12 16 22'X30*	560/630



## ACE/400

400°C/2h elastic coupling to absorb vibrations.

### Features:

- Used between the 400°C/2h fan inlet/outlet and the duct to avoid transmitting vibrations.

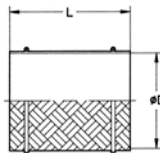

	ØD*	L	Applies to models			Applies to models					
			THT	TCMP	TCR/R	THT	TCMP	TCR/R			
ACE/400-200	200	200	-	820	-	ACE/400-500	500	300	50	2050	1650
ACE/400-224	224	200	-	922	-	ACE/400-560	560	300	56	-	1856
ACE/400-250	250	300	-	1025	-	ACE/400-630	630	300	63	-	2063
ACE/400-280	280	300	-	1128	-	ACE/400-710	710	300	71	-	2271
ACE/400-315	315	300	-	1231	-	ACE/400-800	800	300	80	-	-
ACE/400-355	355	300	-	1435	-	ACE/400-900	900	300	90	-	-
ACE/400-400	400	300	40	1640	1240	ACE/400-1000	1000	300	100	-	-
ACE/400-450	450	300	45	1845	1445	ACE/400-1250	1250	300	125	-	-



## REG Record of manual adjustment.

### Features:

- Their design allows them to be installed in ducting systems to adjust the airflow.

Model	L	ØD*	Model	L	ØD*
REG-80	100	80	REG-250	100	250
REG-100	100	100	REG-280	100	280
REG-112	100	112	REG-315	100	315
REG-125	100	125	REG-355	100	355
REG-140	100	140	REG-400	100	400
REG-150	100	150	REG-450	150	450
REG-160	100	160	REG-500	150	500
REG-180	100	180	REG-560	150	560
REG-200	100	200	REG-630	250	630
REG-224	100	224	REG-800	250	800



## VIS

Outlet hood with protection guard.

### Features:

- Prevents objects and water from entering the fan.

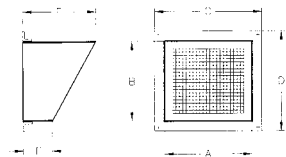

	A	B	C	D	E	F	CJTX-C
VIS-7/7	245	224	-	-	200	80	7/7
VIS-9/9	312	281	-	-	200	80	9/9
VIS-10/10	340	306	-	-	200	80	10/10
VIS-12/12	400	358	-	-	300	80	12/12
VIS-15/15	488	420	-	-	300	80	15/15
VIS-18/18	570	496	-	-	300	80	18/18
VIS-20/20	618	620	-	-	500	80	20/20
VIS-22/22	670	710	-	-	500	80	22/22
VIS-25/25	780	809	-	-	500	80	25/25
VIS-30/28	905	948	-	-	500	80	30/28

	A	B	C	D	E	F	CJMP	CJTJR/R
VIS-820	132	157	-	-	170	56.5	820	-
VIS-922	142	216	-	-	215	56.5	922	-
VIS-1025	167	251	-	-	240	56.5	1025	-
VIS-1128	182	296	-	-	270	56.5	1128	-
VIS-1231	202	321	-	-	290	56.5	1231	-
VIS-1240	317	401	-	-	350	56.5	-	1240
VIS-1435	232	281	-	-	260	56.5	1435	-
VIS-1445	357	451	-	-	385	56.5	-	1445

	A	B	C	D	E	F	CJLINE	CJBS
VIS-1640	252	321	-	-	290	56.5	1640	-
VIS-650	402	501	-	-	420	56.5	-	1650
VIS-1845	286	361	-	-	320	56.5	1845	-
VIS-1856	452	561	-	-	-	-	-	1856
VIS-2050	317	451	-	-	385	56.5	2050	-
VIS-2063	502	631	-	-	515	56.5	-	2063
VIS-2271	562	716	-	-	575	56.5	-	2271

	A	B	C	D	E	F	CJLINE	CJBS
VIS-1131	560	450	-	-	250	100	1131	-
VIS-1235	620	500	-	-	250	100	1235	-
VIS-1640/E	710	560	-	-	250	100	1640	-
VIS-1845/E	800	630	-	-	250	100	1645	-
VIS-1856/E	1000	800	-	-	250	100	1856	-
VIS-2063/E	1120	900	-	-	250	100	2063	-
VIS-2271/E	1190	900	-	-	250	100	2271	-
VIS-2880	1250	1000	-	-	250	100	2880	-
VIS-100	600	600	698	698	485	-	-1240/1850	-
VIS-200	725	725	823	823	576	-	-2056/2263-T	-
VIS-300	800	800	898	898	630	-	-2263-4T/2071-6T-3	-
VIS-400	860	860	958	958	674	-	-2071-4T/6T-5.5/2880	-



## TEJ Outside covers.

Features:

- Avoids water entering ventilation units installed outside.

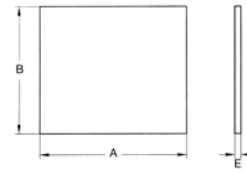

	Applies to models					
	A	B	E	CJMP	CJTCR/R	CJS
TEJ-820	500	550	26	820	-	-
TEJ-922	710	710	26	922	-	-
TEJ-1025	760	760	26	1025	-	-
TEJ-1128	820	820	26	1128	-	-
TEJ-1231	900	900	26	1231	-	1240/1850
TEJ-1435	980	980	26	1435	-	-

	Applies to models					
	A	B	E	CJMP	CJTCR/R	CJS
TEJ-1640	1071	1070	26	1640	1240	2056/2263-6T
TEJ-1845	1170	1170	26	1845	1445	2263-4T/2071/2280
TEJ-1856	1360	1150	26	-	1856	-
TEJ-2050	1260	1260	26	2050	1650	-
TEJ-2063	1500	1300	26	-	2063	-
TEJ-2271	1655	1455	26	-	2271	-

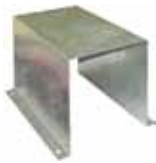

## CM Motor cover for outside work.

Features:

- Avoids water entering motors installed outside.

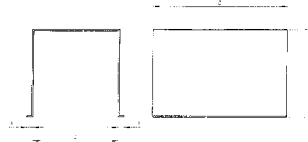

Model	A	B	C	D	Applies to motors of:	
					CV	
CM-1	15	260	200	300	0.25 to 1	
CM-2	15	260	240	300	1.5 to 2	
CM-5.5	15	300	270	330	3 to 5.5	
CM-10	15	380	320	450	7.5 to 10	
CM-20	15	440	350	530	15 to 20	
CM-30	15	440	360	550	more than 20	



## TAC Circular coupling plate.

Features:

- To change rectangular outlet of unit CJS and CJLINE to circular

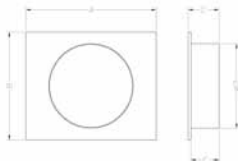

	Applies to models					
	A	B	C	ØD	E	CJS CJLINE
TAC-100	698	698	80	400	50	1240/1850 -
TAC-200	823	823	80	560	50	2056/2263-6T -
TAC-300	898	898	80	630	50	2263-4T/2071-6T-3 -
TAC-400	958	958	80	710	50	2071-4T/6T-5.5/2880 -
TAC-1131	615	505	165	400	150	- 1131
TAC-1235	695	575	165	450	150	- 1235
TAC-1640	785	635	165	500	150	- 1640
TAC-1845	875	705	165	560	150	- 1845
TAC-1856	1075	875	165	700	150	- 1856
TAC-2063	1195	975	165	800	150	- 2063
TAC-2271	1265	975	165	800	150	- 2271
TAC-2880	1325	1075	165	900	150	- 2880



## S Silencers to fit to inlet or outlet.

Features:

- Circular or rectangular silencers to fit to inlet or outlet on centrifugal or axial fans.

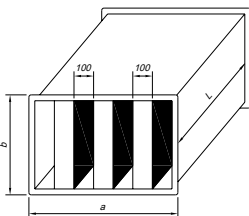

INLET / OUTLET (Rectangular cross section)

	L	a	b	Kg	Replacement dampers (dB) on octave band (Hz)						
					125	250	500	1000	2000	4000	Applicable
SR-1000/900/900	900	1000	900	64	4	10	21	37	44	37	THT-63
SR-1200/900/900	900	1200	900	74	4	10	21	37	44	37	THT-71
SR-1400/1200/900	900	1400	1200	102	4	12	25	41	47	42	THT-80
SR-1800/1200/1200	1200	1800	1200	169	4	12	25	41	47	42	THT-90
SR-1800/1500/1200	1200	1800	1504	195	4	12	25	41	47	42	THT-100

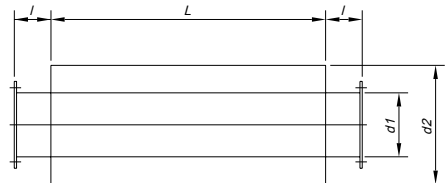
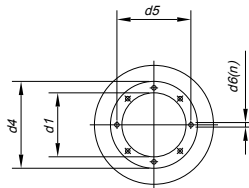

INLET / OUTLET (Circular cross section)

	L	d1	d2	l	d3	d4	d5	d6	n	Kg	Replacement dampers (dB) on octave band (Hz)						
											125	250	500	1000	2000	4000	Applicable
SC-630/900	900	630	800	100	630	720	690	12	12x30°	44	5	8	14	12	13	9	THT-63
SC-710/900	900	710	900	100	710	800	770	12	16x22°30'	65	5	8	13	11	12	8	THT-71
SC-800/900	900	800	1000	100	800	900	860	12	16x22°30'	70	4	8	11	9	9	8	THT-80
SC-900/1200	1200	900	1120	100	900	1000	970	15	16x22°30'	87	5	7	11	11	7	5	THT-90
SC-1000/1200	1200	1000	1200	100	1000	1100	1070	15	16x22°30'	95	4	7	11	10	7	6	THT-100

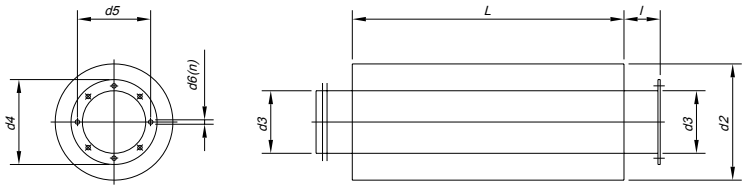

**INLET**

	L	d2	d3	d4	d5	d6	n	Kg	Replacement dampers (dB) on octave band (Hz)						Applicable
									125	250	500	1000	2000	4000	
S-250/600	600	450	250	310	280	10	4x90°	14	5	12	20	24	23	14	CVT-CHT-200/225
S-355/900	900	560	355	430	395	10	8x45°	25	4	12	20	24	18	14	CVT-CHT-250/315
S-500/900	900	710	500	590	560	12	12x30°	35	4	11	18	16	14	11	CVT-CHT-400/450
S-630/900	900	800	630	720	690	12	12x30°	41	5	8	14	12	13	9	CVT-CHT-500
S-710/900	900	900	710	800	770	12	16x22°30'	65	5	8	13	11	12	8	CVT-CHT-560/630

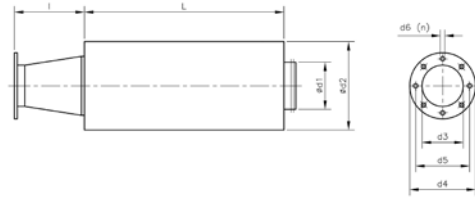

**INLET**

	L	d1	d2	l	d3	d4	d5	d6	n	Kg	Replacement dampers (dB) on octave band (Hz)						Applicable
											125	250	500	1000	2000	4000	
S-315/600/922-A	600	315	500	238	220	278	256	9	8x45°	16	4	8	14	17	14	12	TCMP/CTMP-922
S-355/900/1025-A	900	355	560	224	245	305	282	9	8x45°	25	4	12	20	24	23	14	TCMP/CTMP-1025
S-400/900/1128-A	900	400	600	250	270	348	320	9	8x45°	29	5	12	19	22	18	13	TCMP/CTMP-1128
S-450/900/1231-A	900	450	630	291	295	382	354	9	8x45°	32	5	12	18	20	16	12	TCMP/CTMP-1231
S-500/900/1435-A	900	500	710	284	345	422	394	9	8x45°	35	4	11	18	16	14	11	TCMP/CTMP-1435
S-500/900/1640-A	900	500	710	227	395	464	438	9	8x45°	35	4	11	18	16	14	11	TCMP/CTMP-1640
S-560/900/1845-A	900	560	750	241	445	515	485	9	8x45°	41	4	10	16	14	13	10	TCMP/CTMP-1845
S-630/1200/2050-A	1200	630	800	269	495	565	535	11	8x45°	56	6	13	18	15	15	12	TCMP/CTMP-2050
S-800/1200/2563-A	1200	800	1000	370	595	710	675	14	8x45°	80	5	9	13	11	11	9	TCMP/CTMP-2563
S-400/900/1031-A	900	400	600	202	320	383	356	9	8x45°	29	5	12	19	22	18	13	TCR/R / TCR-1031
S-450/900/1135-A	900	450	630	216	345	425	398	9	8x45°	32	5	12	18	20	16	12	TCR/R / TCR-1135
S-500/900/1240-A	900	500	710	227	395	472	444	11	8x45°	35	4	11	18	16	14	11	TCR/R / TCR-1240
S-560/900/1445-A	900	560	750	241	445	522	495	11	8x45°	41	4	10	16	14	13	10	TCR/R / TCR-1445
S-630/1200/1650-A	1200	630	800	269	495	582	555	11	8x45°	56	6	13	18	15	15	12	TCR/R / TCR-1650
S-710/900/1856-A	900	710	900	301	555	645	615	11	8x45°	65	5	8	13	11	12	8	TCR/R / TCR-1856
S-800/900/2063-A	900	800	1000	329	625	720	688	11	8x45°	70	4	8	11	9	9	8	TCR/R / TCR-2063
S-800/1200/2271-A	1200	800	1000	224	705	800	768	13	8x45°	80	5	9	13	11	11	9	TCR/R / TCR-2271

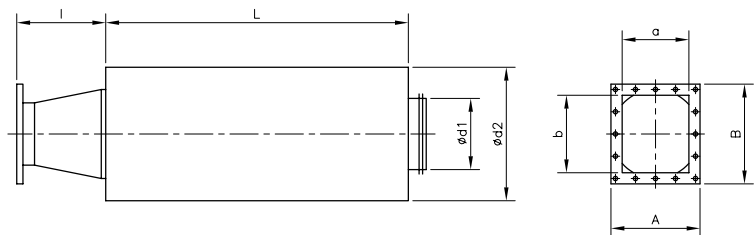

**OUTLET (Rectangular flange)**

	L	d1	d2	l	a	b	A	B	Kg	Replacement dampers (dB) on octave band (Hz)						Applicable
										125	250	500	1000	2000	4000	
S-315/600/922-I	600	315	500	300	216	140	282	204	16	4	8	14	17	14	12	TCMP/CTMP-922
S-355/900/1025-I	900	355	560	300	250	165	314	229	25	4	12	20	24	23	14	TCMP/CTMP-1025
S-400/900/1128-I	900	400	600	300	300	180	364	544	29	5	12	19	22	18	13	TCMP/CTMP-1128
S-450/900/1231-I	900	450	630	300	320	200	384	266	32	5	12	18	20	16	12	TCMP/CTMP-1231
S-500/900/1435-I	900	500	710	300	280	228	344	394	35	4	11	18	16	14	11	TCMP/CTMP-1435
S-500/900/1640-I	900	500	710	300	320	250	404	336	35	4	11	18	16	14	11	TCMP/CTMP-1640
S-560/900/1845-I	900	560	750	450	360	284	444	370	41	4	10	16	14	13	10	TCMP/CTMP-1845
S-630/1200/2050-I	1200	630	800	450	450	315	545	412	56	6	13	18	15	15	12	TCMP/CTMP-2050
S-800/1200/2563-I	1200	800	1000	450	600	410	706	512	80	5	9	13	11	11	9	TCMP/CTMP-2563
S-400/900/1031-I	900	400	600	300	315	250	385	320	29	5	12	19	22	18	13	TCR/R / TCR-1031
S-450/900/1135-I	900	450	630	450	355	280	425	350	32	5	12	18	20	16	12	TCR/R / TCR-1135
S-500/900/1240-I	900	500	710	450	400	315	480	395	35	4	11	18	16	14	11	TCR/R / TCR-1240
S-560/900/1445-I	900	560	750	450	450	355	540	445	41	4	10	16	14	13	10	TCR/R / TCR-1445
S-630/1200/1650-I	1200	630	800	450	500	400	590	490	56	6	13	18	15	15	12	TCR/R / TCR-1650
S-710/900/1856-I	900	710	900	450	560	450	660	550	65	5	8	13	11	12	8	TCR/R / TCR-1856
S-800/900/2063-I	900	800	1000	450	630	500	750	620	70	4	8	11	9	9	8	TCR/R / TCR-2063
S-800/1200/2271-I	1200	800	1000	450	710	560	840	690	80	5	9	13	11	11	9	TCR/R / TCR-2271
S-800/1201/2380-I	1200	800	1000	450	560	800	680	920	90	5	9	13	11	11	9	TCR/R / TCR-2380

## Alphabetical index of references

CBDT	95	CJTHT/PLUS	20
CHT	156	CJTX-C	123
CI	88	CSX	138
CJBDT	95	CTMP	102
CJEC	153	CVT	156
CJLINE	148	HTMF	90
CJMD	108	KIT DE SOBREPRESIÓN	162
CJMP	117	TCMP	117
CJS	105	TCR	99
CJSRX	138	TCR/R	112
CJSX	132	THT	12
CJTCR/R	112	THT/IMP	78
CJTHT	24	TÚNEL JETFAN	82
CJTHT/DUPLEX/ATEX	30	VMSF	86

## Alphabetical index of references ACCESSORIES

ACE-400	175	P-400	172
AR	168	PA	174
B	173	PL	172
BAC	174	PS	174
BD	173	PT	175
BIC	174	R/THT	172
BTUB	173	REG	175
C2V	168	REJ	176
CABLE BOX	168	RFM	169
CENTRAL CO	166	RFT	169
CM	176	RM	168
CUADROS ELECTRICOS	171	RPA	172
IAT	168	RT	172
INT	168	S	176
MS	174	TAC	176
P	172	VIS	175



# OUR PRODUCTS



In-line duct fans



Axial fans



Centrifugal fans



Fans for smoke extraction  
400°C/2h - 300°C/1h



ATEX Fans for explosive atmospheres

**NEW**



Roof fans



Ventilation systems  
for houses



Heat recovery units



Filtration units



Air curtains



Efficient Energy Applications

**NEW**



**Ask us for information.**

Ventilation Software. General Catalogue.



Crta. de Berga, km 0.7  
E-08580 St. Quirze de Besora  
BARCELONA (Spain)  
Tel. +34 93 852 91 11  
Fax. +34 93 852 90 42

comercial@sodeca.com  
**Export sales:** ventilation@sodeca.com  
[www.sodeca.com](http://www.sodeca.com)





Ctra. de Berga, km 0.7  
E-08580 SANT QUIRZE DE BESORA  
Barcelona - SPAIN  
Tel. +34 93 852 91 11  
Fax +34 93 852 90 42  
comercial@sodeca.com  
Export sales: ventilation@sodeca.com  
www.sodeca.com



## Export sales

### SODECA EXPORT

Ctra. de Berga, km 0,7  
E-08580 SANT QUIRZE  
DE BESORA  
Barcelona - SPAIN  
Tel. +34 93 852 91 11  
Fax +34 93 852 90 42  
ventilation@sodeca.com

### PORTUGAL

Sr. Albert Bartés  
E-08580 SANT QUIRZE DE BESORA  
Barcelona - SPAIN  
Tel. +34 93 852 91 11  
Fax +34 93 852 90 42  
comercial@sodeca.com

### SODECA AMÉRICA

USA - CANADÁ - MÉXICO  
AMÉRICA DEL SUR  
Sodeca Ventiladores Ltda  
Avda. Puerta Sur 03380  
San Bernardo, SANTIAGO, CHILE  
Francesc Bertran  
fbertran@sodeca.com  
Tel. +56 (0)2 840 5582

### SODECA ÁREA CARIBE

Sr. Carlos A. Hernández Gil  
Residencial Miramar N° 120B-7ma Ave. N° 1805  
entre 18 y 20.  
Miramar Playa, CIUDAD DE LA HABANA, CUBA  
Tel. 00537 20 43721  
sodeca@enet.cu



Ctra. de Berga, km 0,7  
E-08580 SANT QUIRZE DE BESORA  
(Barcelona - Spain)  
Tel. +34 93 852 91 11  
Fax +34 93 852 90 42  
comercial@sodeca.com  
Export sales: ventilation@sodeca.com

**[www.sodeca.com](http://www.sodeca.com)**

