

CBD



CDXR



CSXR



CBXT



CJBD



CJDXR



CJBC



LOW-PRESSURE CENTRIFUGAL FANS

WITH MULTI-BLADE OR BACKWARD-CURVED IMPELLERS

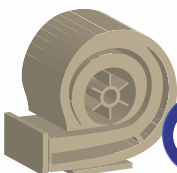

According
EU Regulation



OUR COMMITMENT TO THE ENVIRONMENT

Sodeca has begun a new stage of study and design of new trends in ventilation which will help to preserve the environment and to make the energy saving which so much concerns today's society.



To obtain an **improvement in energy efficiency** of fans and of ventilation facilities, the engineering department of Sodeca has **balanced the energy consumption of the fans** with their maximum performance, in the habitual areas of work. This has required a restructuring of the curves and their presentation in this and future Sodeca catalogues.

SODECA has concentrated its activity on the production of industrial fans, ventilation systems and extractors for the removal of smoke in case of fire since 1983, when it was founded.

SODECA's fans and extractors are present in all European countries and in many parts of the world, thanks to the quality of the product and the methods of research and development used.

Our quality procedures used and certified by BUREAU VERITAS, in accordance with ISO 9001:2008, are another of the reasons which make **SODECA** one of the best and most renowned fan manufacturers in Europe.

Without a doubt, the most important factor to achieve our objectives is the human factor, the great professionals who work at your service, offering not only ventilation equipment but also solutions to any ventilation need required by our customers.

We sincerely offer you the possibility of visiting our facilities in Sant Quirze de Besora, with over 16,000 square metres of built area, where you will be able to see our fan manufacture with perfect clarity and with the highest standards of quality, complying with the ISO and AMCA standards.

This catalogue is only a small part of our possibilities. Do not hesitate to contact us. We will put all our experience and our human resources at your disposal.



*installations
headquarters of
SODECA s.a.,
at Sant Quirze
de Besora and
manufacturing plant
in Santiago
de Chile.*

LOW-PRESSURE CENTRIFUGAL FANS

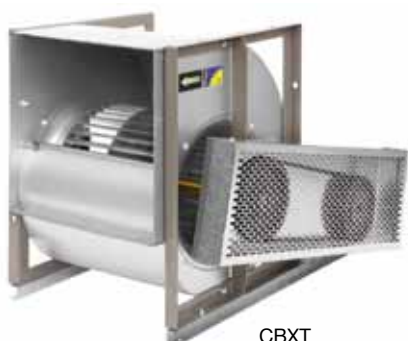

CBXT



TSAT



CDXRT



CSXRT

Making serving market demand a priority, Sodeca has expanded the manufacture of low pressure fans creating a complete catalogue to satisfy our customers' requirements..

The manufacture of these low pressure galvanised sheet metal fans uses our multi-blade impellers with forward facing blades crimped in a steel disc and reinforced through the centre with a double disc, or backward curved impellers with riveted or soldered backward curved blades depending on size. The thickness of the sheet metal makes them highly robust.

The casings have aerodynamic sides that together with the vent deflectors prevent turbulence formation and reduce the fan sound level.

You'll find solutions to your ventilation challenges with the the fans we present in this low pressure fan catalogue:

- . Double-inlet fans
- . Single-inlet fans
- . Fans for smoke extraction
- . With a direct motor and multi-blade impeller with forward-facing blades
- . Belt-driven fans and multi-blade impeller with forward-facing blades
- . Belt-driven fans and backward-curved impeller with backward-facing blades
- . With galvanised sheet box or aluminium profile

The union of the experience acquired over decades of work in the fans manufacture together with the technology supplied by our engineering department has made it possible for Sodeca to become one of the largest manufacturers of ventilation in the world.

NEW SERIES. NEW PRODUCTS.
NEW CATALOGUES.
 NEW BUSINESS OPPORTUNITIES.



Ask us for information



AXIAL AND
ROOF FANS



CENTRIFUGAL
AND IN-LINE
DUCT FANS



LOW-PRESSURE
CENTRIFUGAL
FANS



FANS FOR
SMOKE
EXTRACTION

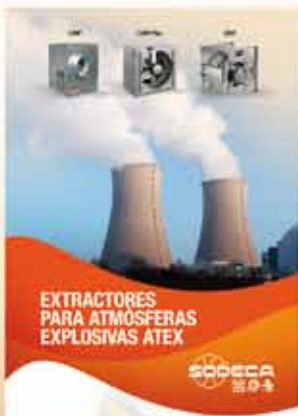

FANS FOR
ATEX EXPLOSIVE
ATMOSPHERES



VENTILATION SYSTEM
FOR HOUSES



HEAT RECOVERY
SYSTEMS AND
FILTRATION UNITS



AIR CURTAINS
FOR DOMESTIC AND
COMMERCIAL
APPLICATIONS

Crta. de Berga, km 0.7
 E-08580 St. Quirze de Besora
 BARCELONA (Spain)
 Tel. +34 93 852 91 11
 Fax. +34 93 852 90 42
 comercial@sodeca.com
 Export sales: ventilation@sodeca.com
 www.sodeca.com



FULFILMENT OF STANDARDS

SODECA's fans and extractors comply with the following standards:

QUALITY	
ISO 9001:2008	Sistemas de gestión de la calidad. Requisitos. Quality management systems -- Requirements
TESTS	
ISO 5801	Ventiladores industriales. Industrial fans -- Performance testing using standardized airways Industrial fans -- Performance testing using standardized airways
AMCA 210-99	Ventiladores industriales. Métodos de ensayos de ventiladores y su representación de ensayos. Laboratory Methods of Testing Fans for Aerodynamic Performance Rating
UNE 100212:1990	Ventiladores. Dispositivos e instalaciones para el ensayo de ventiladores.
ISO 13350	Ventiladores industriales. Ensayos de comportamiento de ventiladores de chorro. Industrial fans -- Performance testing of jet fans
ISO 13348	Industrial fans -- Tolerances, methods of conversion and technical data presentation
FANS FOR HIGH TEMPERATURES	
EN 12101-3:2002	Sistemas de control de humos y calor. Parte 3: Especificaciones para aireadores extractores de humos y calor mecánicos. Smoke and heat control systems - Part 3: Specification for powered smoke and heat exhaust ventilators
ACOUSTICS	
ISO 3744	Acústica. Determinación de los niveles de potencia acústica de fuentes de ruido a partir de la presión acústica. Método de ingeniería para condiciones de campo libre sobre un plano reflectante. Acoustics -- Determination of sound power levels of noise sources using sound pressure -- Engineering method in an essentially free field over a reflecting plane
BALANCE AND VIBRATIONS	
ISO 1940-1	Vibraciones mecánicas. Calidad de equilibrado Mechanical vibration -- Balance quality requirements for rotors in a constant (rigid) state -- Part 1: Specification and verification of balance tolerances
ISO 10816-1	Vibraciones mecánicas. Evaluación de las vibraciones de máquinas Mechanical vibration -- Evaluation of machine vibration by measurements on non-rotating parts -- Part 1: General guidelines
ISO 14694	Ventiladores industriales. Especificaciones para equilibrado y niveles de vibración Industrial fans -- Specifications for balance quality and vibration levels
SAFETY (Declaration of EC Compliance)	
EN ISO 12100-1	Seguridad de las máquinas. Conceptos básicos, principios generales para el diseño. Parte 1: Terminología básica, metodología. Safety of machinery -- Basic concepts, general principles for design -- Part 1: Basic terminology, methodology
EN ISO 12100-2	Seguridad de las máquinas. Conceptos básicos, principios generales para el diseño. Parte 2: Principios técnicos. Safety of machinery -- Basic concepts, general principles for design -- Part 2: Technical principles
EN 60204-1	Seguridad de las máquinas. Equipo eléctrico de las máquinas. Parte 1: Requisitos generales. Safety of machinery - Electrical equipment of machines - Part 1: General requirements
EN 294	Seguridad de máquinas. Distancias de seguridad para impedir que se alcancen zonas peligrosas con los miembros superiores Safety of machinery; safety distances to prevent danger zones from being reached by the upper limbs
ISO 13857	Seguridad de máquinas. Distancias de seguridad para impedir que se alcancen zonas peligrosas con los miembros superiores e inferiores. Safety of machinery -- Safety distances to prevent danger zones being reached by upper and lower limbs
UNE 100250	Ventiladores industriales. Seguridad mecánica de los ventiladores (equivalente ISO 12499)
ISO 12499	Ventiladores industriales. Seguridad mecánica en los ventiladores Industrial fans -- Mechanical safety of fans -- Guarding
DIRECTIVES	
Directiva 2006/42/CE	Directiva de máquinas Machinery Directive
Directiva 2006/95/CE	Directiva de baja tensión Low Voltage Directive
Directiva 2004/108/CE	Directiva compatibilidad electromagnética EMC Directive
Directiva 89/106/CE	Directiva productos de construcción Construction Products Directive (CPD)
ATEX EXECUTIONS	
Directiva ATEX 94/9/CE	Aparatos y sistemas de protección para uso en atmósferas potencialmente explosivas Equipment and protective systems intended for use in potentially explosive atmospheres
EN 14986	Diseño de ventiladores para trabajar en atmósferas potencialmente explosivas. Design of fans working in potentially explosive atmospheres
EN 13463-1	Equipos no eléctricos destinados a atmósferas potencialmente explosivas. Parte 1: Requisitos y metodología básica. Non-electrical equipment for use in potentially explosive atmospheres - Part 1: Basic method and requirements
EN 1127-1	Atmósferas explosivas. Prevención y protección contra la explosión. Parte 1: Conceptos básicos y metodología. Explosive atmospheres - Explosion prevention and protection - Part 1: Basic concepts and methodology



Fans and ventilation units

**DOUBLE-INLET
WITH DIRECT MOTOR**

CBD CBD 3V	CJBD CJBD/AL	CJBC CJBC/ECO	TWIN
 <p>Double-inlet centrifugal fans with direct motor</p>	 <p>Ventilation units with direct motor and double-inlet fan</p>	 <p>Exhaust fans and compact extraction units for direct operation</p>	 <p>Ventilation units with direct motor and two independent fans</p>
8	13	15	19



Fans and ventilation units

**DOUBLE-INLET
WITH BELT-DRIVEN MOTOR**

CBX CBXC CBXR CBXT	CJBX CJBX/AL
 <p>Low-pressure, double-inlet belt-driven centrifugal fans</p>	 <p>Belt-driven ventilation units with double-inlet fan</p>
21	31



Fans and ventilation units

**SINGLE-INLET
WITH BELT-DRIVEN MOTOR**

TSA TSAT CJTSA
 <p>Belt-driven fans with single-inlet</p>
40



Fans and ventilation units

DOUBLE-INLET WITH BELT-DRIVEN MOTOR WITH BACKWARD-CURVED IMPELLERS

CDXR CDXRT CJDXR



Double-inlet belt-driven fans

48



Fans and ventilation units

SINGLE-INLET WITH BELT-DRIVEN MOTOR WITH BACKWARD-CURVED IMPELLERS

CSXR CSXRT CJSXR



Single-inlet belt-driven fans

56

Fans

FOR SMOKE EXTRACTION 400°C/2h - 300°C/1h



CBDT



Centrifugal double-inlet and direct motor fans for working inside fire danger zones: 400°C/2h and 300°C/1h, with possibility of single-phase motor

68

CJBDT



Extraction units to work inside fire danger zones at 400°C/2h and 300°C/1h, with soundproof box

68



CJTX-C



400°C/2h extraction units with inside belt-driven motor and automatic belt tensing device

72

CJSX



400°C/2h belt-driven extraction units with single-inlet fan

81

CJSRX



400°C/2h centrifugal fans with backwards-curved impeller

87

CSX



400°C/2h centrifugal belt-driven fan

87

CBD CBD 3V



High-quality, robust impeller, dynamically balanced in accordance with ISO-1940

CBD: Centrifugal double-inlet fans with direct motor and impeller with forward-facing blades

CBD 3V: Centrifugal double-inlet fans with direct motor and impeller with forward-facing blades three speed

Fan:

- Galvanized sheet steel casing
- Impeller with forward-facing blades made from galvanised sheet steel
- Fan with PSB feet

Motor:

- Class F closed motors with incorporated thermal protector, ball bearings and IP-54 protection
- Single-phase 220-240V.-50Hz. and three-phase 220-240/380-415V.-50Hz.
- Max. air temperature to transport: -20°C.+ 60°C.

Finish:

- Anticorrosive galvanized sheet steel.

Order code



Code	Impeller size in mm mm inches	Number of motor poles	T=Three-phase M=Single-phase	Power motor (c.v.)	With 3 speed motors
CBD: Centrifugal double-inlet fans with direct motor and impeller with forward-facing blades	1919 7/7	4=1400 r/min. 50 Hz			
CBD 3V: Centrifugal double-inlet fans with direct motor and impeller with forward-facing blades three speed	2525 9/9	6=900 r/min. 50 Hz			
	2828 10/10				
	3333 12/12				
	3939 15/15				

Technical characteristics

Model	Maximum Speed (r/min)	Equivalent in inches	Maximum admissible current (A)		Installed Power (kW)	Maximum Airflow (m³/h)	Sound Level dB(A)	Approx. weight (Kg)
			230V	400V				
CBD-1919-4M 1/5	1230	7/7	1.75		0.15	1520	59	7.0
CBD-1919-6M 1/10	820	7/7	0.98		0.07	1230	53	7.0
CBD-2525-4M 1/2	1320	9/9	3.30		0.37	2800	66	13.2
CBD-2525-4M 3/4	1310	9/9	4.50		0.55	3600	70	14.0
CBD-2525-6M 1/5	850	9/9	1.50		0.15	2200	60	11.5
CBD-2525-6M 1/3	830	9/9	2.40		0.25	2700	62	12.7
CBD-2828-4M 1/2	1320	10/10	3.30		0.37	2800	65	15.7
CBD-2828-4M 3/4	1310	10/10	4.50		0.55	3950	70	16.5
CBD-2828-6M 1/3	830	10/10	2.40		0.25	3200	62	15.2
CBD-2828-6M 3/4	900	10/10	4.40		0.55	3600	64	21.0
CBD-3333-6T 1 1/2	900	12/12	6.60	3.80	1.10	7800	75	24.5
CBD-3333-6M 3/4	850	12/12	5.00		0.55	4900	64	23.0
CBD-3333-6M 1	850	12/12	6.30		0.75	6000	71	24.0
CBD-3939-6T 3	890	15/15	10.90	6.30	2.20	11900	75	39.0
CBD-1919-4M 1/5 3V	1230	7/7	1.75		0.15	1520	59	7
CBD-2525-4M 1/2 3V	1320	9/9	3.3		0.37	2800	66	13.2
CBD-2525-4M 3/4 3V	1310	9/9	4.5		0.55	3600	70	14
CBD-2525-6M 1/3 3V	830	9/9	2.4		0.25	2700	62	12.7
CBD-2828-4M 1/2 3V	1320	10/10	3.3		0.37	2800	65	15.7
CBD-2828-4M 3/4 3V	1310	10/10	4.5		0.55	3950	70	16.5
CBD-2828-6M 1/3 3V	830	10/10	2.4		0.25	3200	62	15.2
CBD-2828-6M 3/4 3V	900	10/10	4.4		0.55	3600	64	21
CBD-3333-6M 3/4 3V	850	12/12	5		0.55	4900	64	23
CBD-3333-6M 1 3V	850	12/12	6.3		0.75	6000	71	24

Acoustic features

Sound power Lw(A) spectrum in dB(A) via frequency band in Hz. Maximum speed

Model	63	125	250	500	1000	2000	4000	8000	Model	63	125	250	500	1000	2000	4000	8000
CBD-1919-4M 1/5	29	44	55	63	65	64	63	55	CBD-1919-4M 1/5 3V	29	44	55	63	65	64	63	55
CBD-1919-6M 1/10	23	38	49	57	59	58	57	49	CBD-2525-4M 1/2 3V	36	51	62	70	72	71	70	62
CBD-2525-4M 1/2	36	51	62	70	72	71	70	62	CBD-2525-4M 3/4 3V	40	55	66	74	76	75	74	66
CBD-2525-4M 3/4	40	55	66	74	76	75	74	66	CBD-2525-6M 1/3 3V	32	47	58	66	68	67	66	58
CBD-2525-6M 1/5	30	45	56	64	66	65	64	56	CBD-2828-4M 1/2 3V	35	50	61	69	71	70	69	61
CBD-2525-6M 1/3	32	47	58	66	68	67	66	58	CBD-2828-4M 3/4 3V	40	55	66	74	76	75	74	66
CBD-2828-4M 1/2	35	50	61	69	71	70	69	61	CBD-2828-6M 1/3 3V	32	47	58	66	68	67	66	58
CBD-2828-4M 3/4	40	55	66	74	76	75	74	66	CBD-2828-6M 3/4 3V	34	48	60	68	70	69	67	60
CBD-2828-6M 1/3	32	47	58	66	68	67	66	58	CBD-3333-6M 3/4 3V	34	49	60	68	70	69	68	60
CBD-2828-6M 3/4	34	48	60	68	70	69	67	60	CBD-3333-6M 1 3V	41	56	67	75	77	76	75	67
CBD-3333-6T 1 1/2	45	60	71	79	81	80	79	71									
CBD-3333-6M 3/4	34	49	60	68	70	69	68	60									
CBD-3333-6M 1	41	56	67	75	77	76	75	67									
CBD-3939-6T 3	48	62	74	81	84	83	81	73									

Dimensions in mm

CBD- 1919...3333

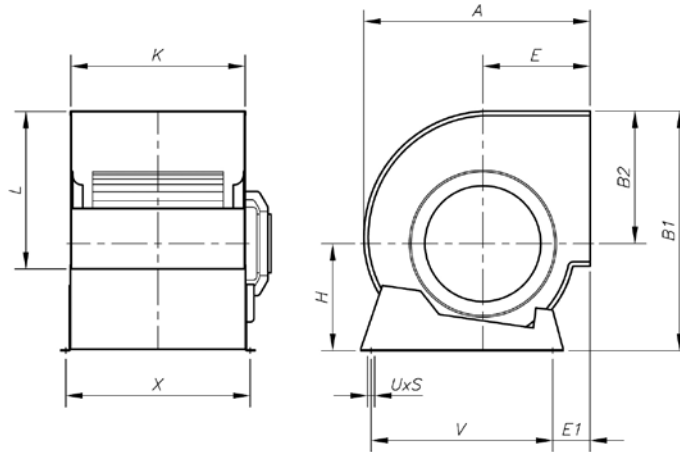

CBD- 3939

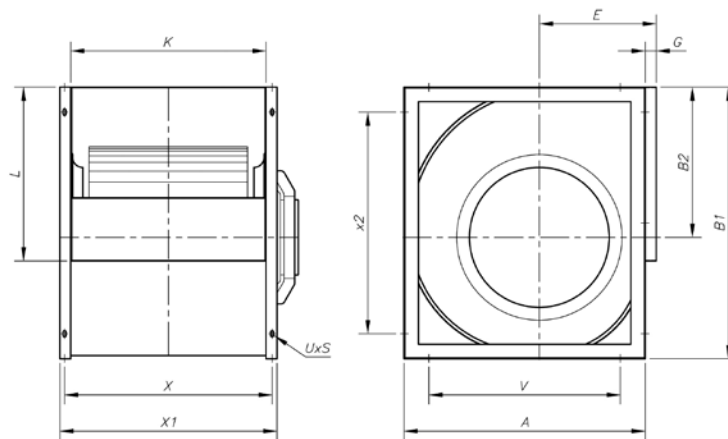

Model	Equiv. in inches	A	B1	B2	E	E1	G	H	K	L	UxS	V	X	x1	x2
CBD-1919	7/7	315	333	189	152	64	-	144	230	208	9x13	225	258	-	-
CBD-2525	9/9	380	400	218	183	78	-	182	300	263	9x13	275	328	-	-
CBD-2828	10/10	422	450	246	202	73	-	204	326	292	9x17	315	355	-	-
CBD-3333	12/12	493	526	290	230	82	-	236	387	345	9x17	390	415	-	-
CBD-3939	15/15	553	632	348	265	-	30	-	473	404	9x17	406	500	533	406

Characteristic Curves

Q = Airflow in m³/h, m³/s and cfm.

Pe= Static pressure in mm.w.c., Pa and in wg.

CBD

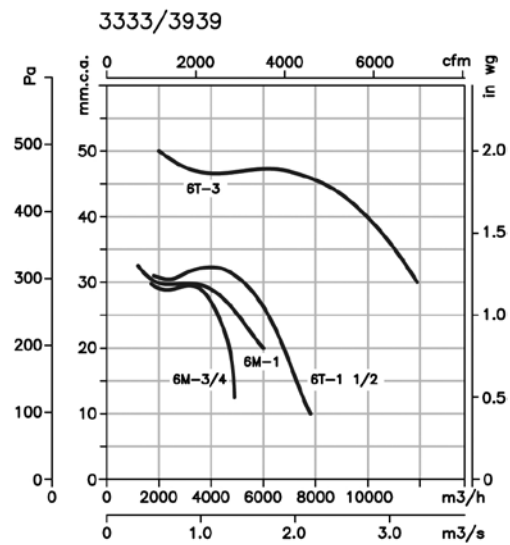
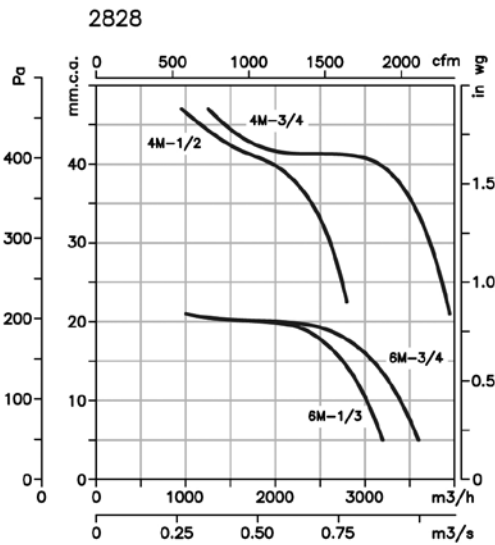
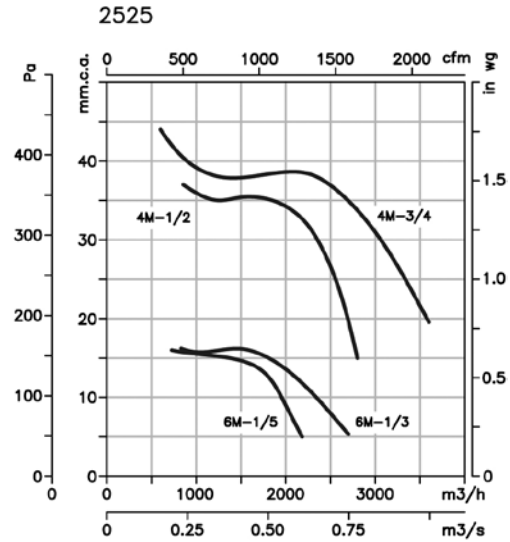
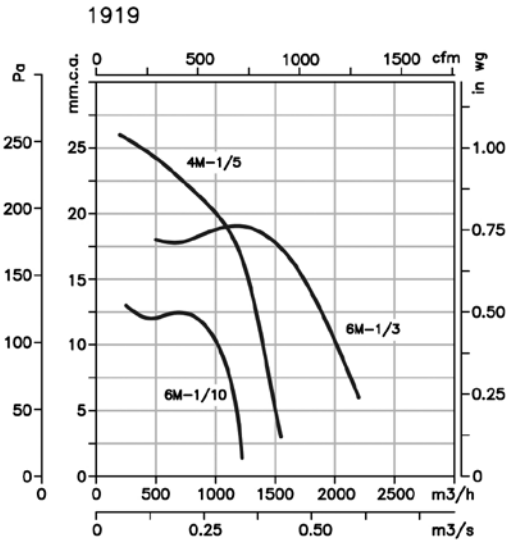

Characteristic Curves

Q = Airflow in m³/h, m³/s and cfm.

Pe= Static pressure in mm.w.c., Pa and in wg.

CBD 3V

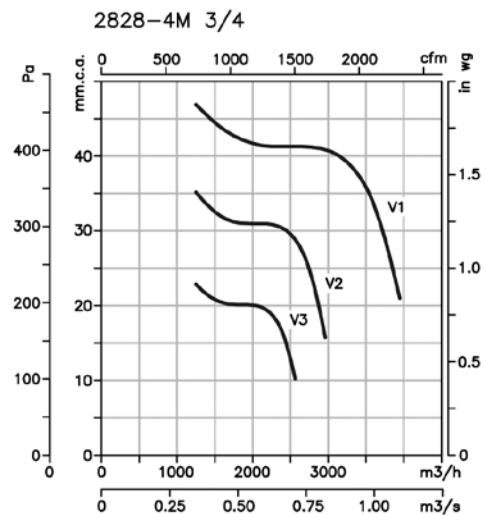
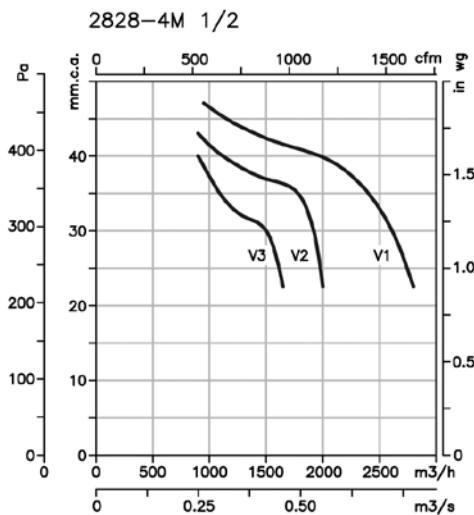
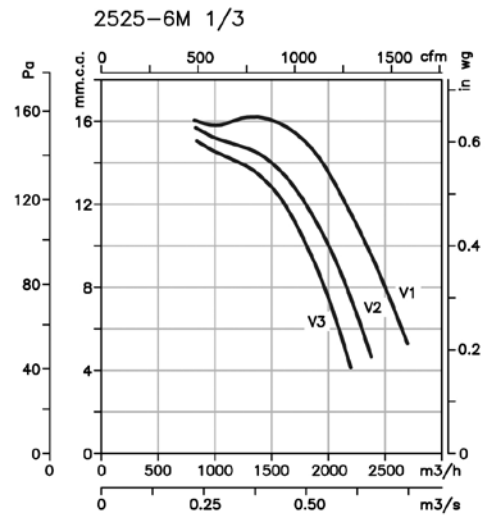
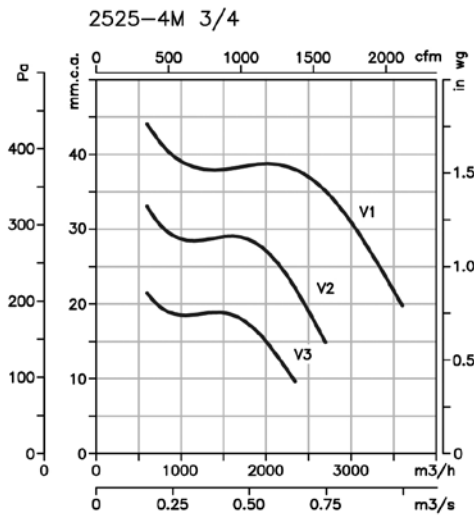
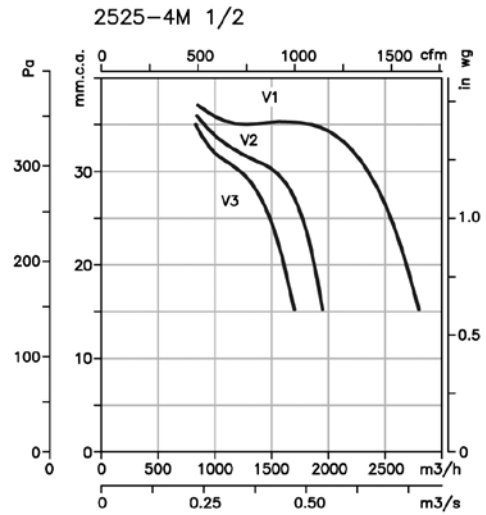
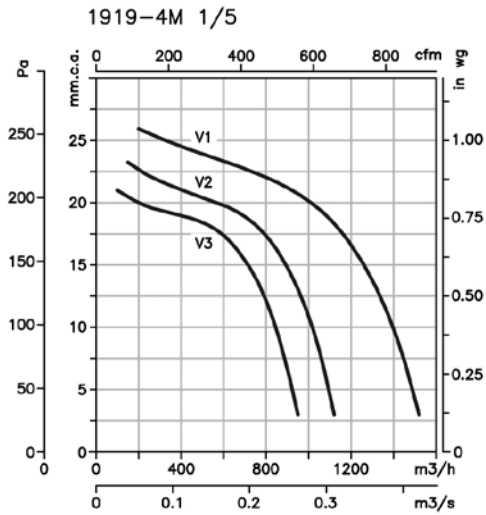

Characteristic Curves

Q = Airflow in m³/h, m³/s and cfm.

Pe= Static pressure in mm.w.c., Pa and in wg.

CBD 3V

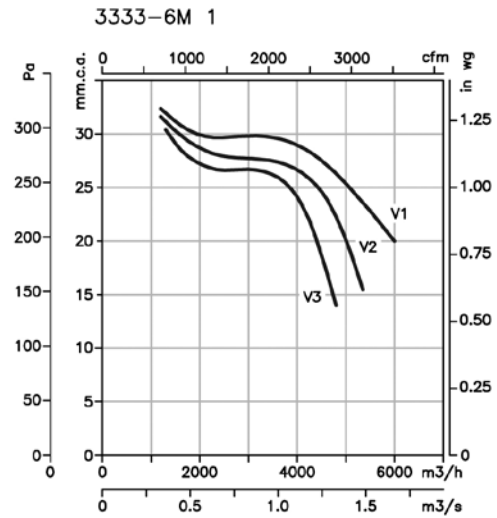
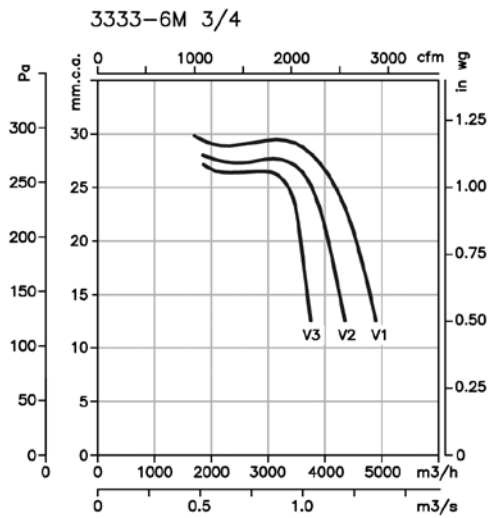
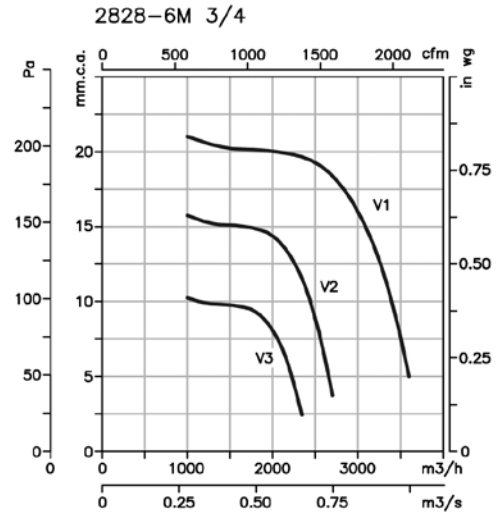
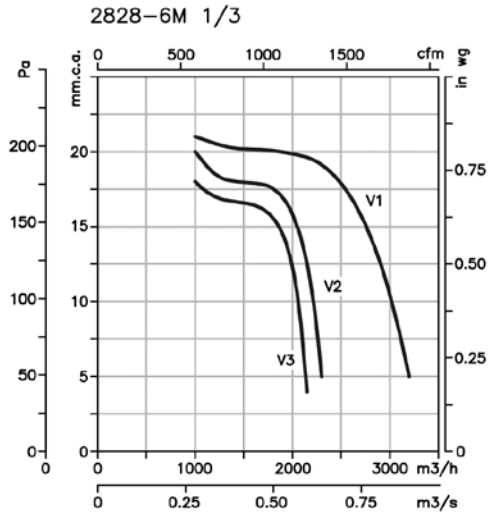

Accessories



Acoustic features

Sound power Lw(A) spectrum in dB(A) via frequency band in Hz.

Model	63	125	250	500	1000	2000	4000	8000	Model	63	125	250	500	1000	2000	4000	8000
CJBD-1919-4M 1/5	43	54	58	62	64	63	62	53	CJBD-2828-4M 3/4	55	66	70	74	76	75	74	65
CJBD-1919-6M 1/10	38	49	53	57	59	58	57	48	CJBD-2828-6M 1/3	46	57	61	65	67	66	65	56
CJBD-2525-4M 1/2	51	62	66	70	72	71	70	61	CJBD-3333-6T 1 1/2	59	70	74	78	80	79	78	69
CJBD-2525-4M 3/4	55	66	70	74	76	75	74	65	CJBD-3333-6M 3/4	48	59	63	67	69	68	67	58
CJBD-2525-6M 1/5	44	55	59	63	65	64	63	54	CJBD-3333-6M 1	55	66	70	74	76	75	74	65
CJBD-2525-6M 1/3	46	57	61	65	67	66	65	56	CJBD-3939-6T 3	61	72	77	81	83	81	80	71
CJBD-2828-4M 1/2	50	61	65	69	71	70	69	60									

Dimensions in mm

CJBD

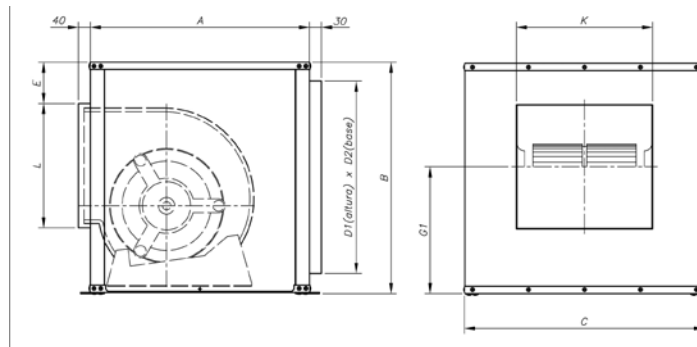

Model	Equiv. in Inches	A	B	C	E	D1xD2	G1	L	K
CJBD-1919	7/7	450	460	500	74	364x404	278	216	238
CJBD-2525	9/9	500	522	550	74	426x454	314	268	305
CJBD-2828	10/10	550	575	600	74	479x504	353	296	330
CJBD-3333	12/12	650	650	700	74	554x604	413	346	390
CJBD-3939	15/15	800	755	800	74	659x704	475,5	411	482

CJBD/AL

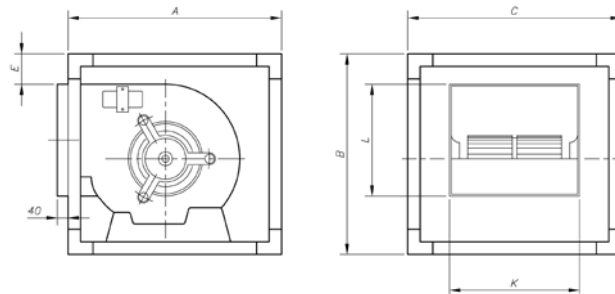

Model	Equiv. in Inches	A	B	C	E	L	K
CJBD/AL-1919	7/7	460	460	460	75	216	238
CJBD/AL-2525	9/9	520	520	520	75	268	305
CJBD/AL-2828	10/10	575	575	575	75	296	330
CJBD/AL-3333	12/12	650	650	650	75	346	390
CJBD/AL-3939	15/15	755	755	755	85	411	482

Characteristic Curves

See characteristic curves, CBD series.

Accessories



CJBC CJBC/ECO

CJBC: Compact extraction units direct drive for community housing
CJBC/ECO: Compact extraction units direct drive for community housing with constant pressure control.

Fan:

- Galvanised sheet steel structure with thermal insulation and soundproofing.
- Impeller with forward-facing blades made from galvanised sheet steel
- Stuffing-box for cable input
- CJBC/ECO: It incorporates a low-pressure switch and speed regulator by means of a frequency converter to maintain a constant pressure

Motor:

- Class F closed motors with incorporated thermal protector, ball bearings and IP-54 protection
- Single-phase 220-240V.-50Hz. and three-phase 220-240/380-415V.-50Hz.
- Max. air temperature to transport: -20°C.+ 60°C.

Finish:

- Anticorrosive galvanized sheet steel.

On request:

- With circular inlet



CJBC



CJBC/ECO

Example of use

SELF-REGULATING CONTROL OPTION



CJBC



BE ALIZE



EA



MOISTURE REGULATING CONTROL OPTION



CJBC/ECO



BE ALIZE-H



EA-A-HY

Order code

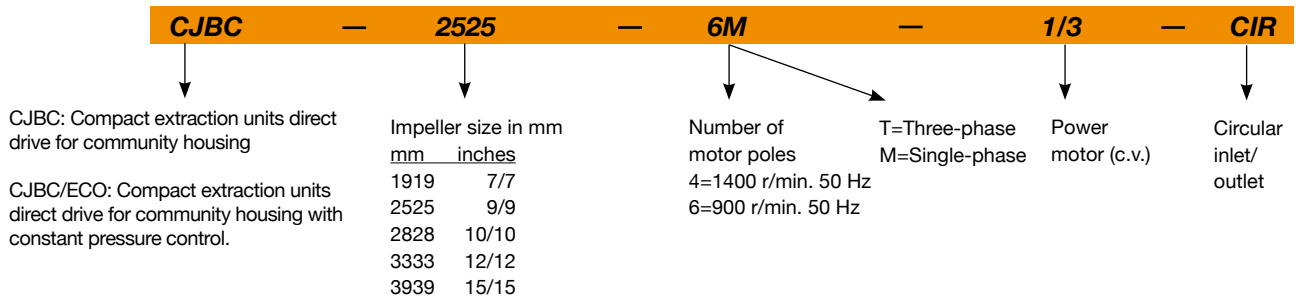

Technical characteristics

Model	Speed (r/min)	Equivalent Inches	Maximum admissible current (A)		Installed Power (kW)	Maximum Airflow (m³/h)	Sound pressure level dB(A)	Approx. weight (Kg)
			230V	400V				
CJBC-1919-4M 1/5	1230	7/7	1.75		0.15	1368	58	15.7
CJBC-1919-6M 1/10	820	7/7	0.98		0.07	1107	53	15.7
CJBC-2525-4M 3/4	1310	9/9	4.50		0.55	3240	70	23.3
CJBC-2525-6M 1/3	830	9/9	2.40		0.25	1980	61	22.3
CJBC-2828-4M 3/4	1310	10/10	4.50		0.55	2430	70	27.3
CJBC-2828-6M 1/3	830	10/10	2.40		0.25	2880	61	26.2
CJBC-3333-6M 1	850	12/12	6.30		0.75	5400	70	38.3
CJBC-3333-6T 1 1/2	900	12/12	6.60	3.80	1.10	7020	74	38.7
CJBC-3939-6T 3	890	15/15	10.90	6.30	2.20	10710	74	58.0
CJBC/ECO-3333-6T 1 1/2	900	12/12	6.6	3.8	1.1	7020	74	40.6
CJBC/ECO-3939-6T 3	890	15/15	10.9	6.3	2.2	10710	74	60.0

Acoustic features

The specified values are determined according to free field measurements of sound levels in dB(A) at an equivalent distance of twice the fan's span plus the impeller's diameter, with a minimum of 1.5 m.

Sound power Lw(A) spectrum in dB(A) via frequency band in Hz. Maximum speed

Model	63	125	250	500	1000	2000	4000	8000	Model	63	125	250	500	1000	2000	4000	8000
CJBC-1919-4M 1/5	43	54	58	62	64	63	62	53	CJBC-3333-6M 1	55	66	70	74	76	75	74	65
CJBC-1919-6M 1/10	38	49	53	57	59	58	57	48	CJBC-3333-6T 1 1/2	59	70	74	78	80	79	78	69
CJBC-2525-4M 3/4	55	66	70	74	76	75	74	65	CJBC-3939-6T 3	61	72	77	81	83	81	80	71
CJBC-2525-6M 1/3	46	57	61	65	67	66	65	56	CJBC/ECO-3333-6T 1 1/2	59	70	74	78	80	79	78	69
CJBC-2828-4M 3/4	55	66	70	74	76	75	74	65	CJBC/ECO-3939-6T 3	61	72	77	81	83	81	80	71
CJBC-2828-6M 1/3	46	57	61	65	67	66	65	56									



Version with circular inlet/outlet

Dimensions in mm

CJBC

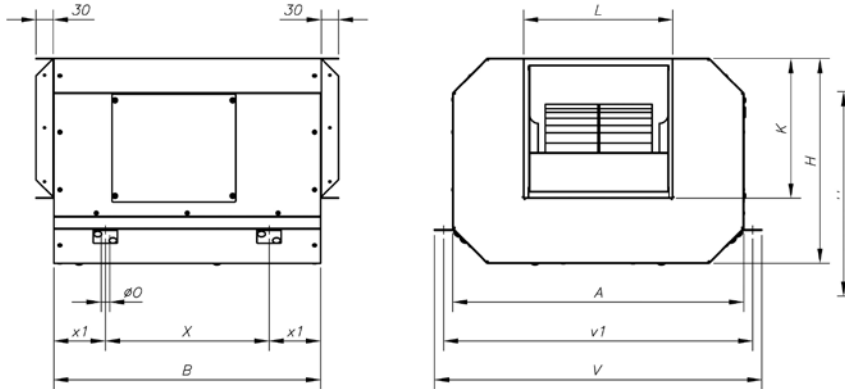

Model	A	B	H	K	L	øO	V	v1	X	x1	Z
CJBC-1919-4M -1/5	480	440	338	230	246	15	540	510	270	85	-
CJBC-1919-6M -1/10	480	440	338	230	246	15	540	510	270	85	-
CJBC-2525-4M -3/4	630	575	415	287	315	15	685	655	375	100	-
CJBC-2525-6M -1/3	630	575	415	287	315	15	685	655	375	100	-
CJBC-2828-4M -3/4	696	645	466	312	348	15	752	722	445	100	-
CJBC-2828-6M -1/3	696	645	466	312	348	15	752	722	445	100	-
CJBC-3333-6M -1	825	760	544	364	460	15	882	852	510	125	-
CJBC-3333-6T -1 1/2	825	760	544	364	406	15	882	852	510	125	-
CJBC-3939-6T -3	933	900	636	426	493	15	1050	1020	650	125	-

CJBC/ECO

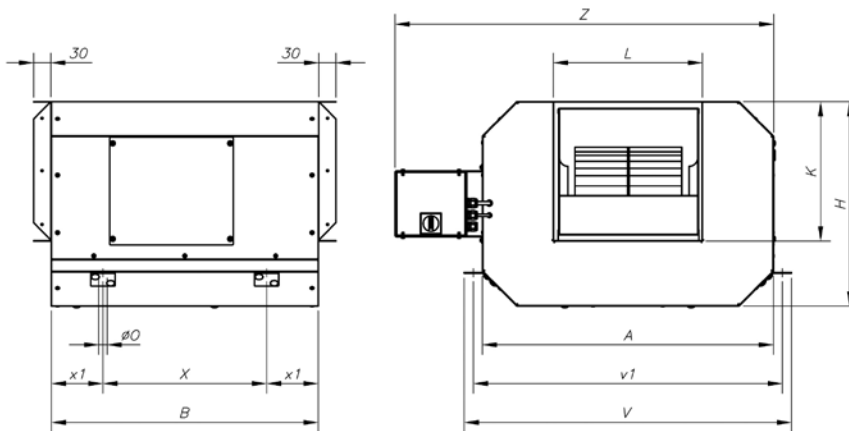

Model	A	B	H	K	L	øO	V	v1	X	x1	Z
CJBC/ECO-3333-6T -1 1/2	825	760	544	364	406	15	882	852	510	125	1080
CJBC/ECO-3939-6T -3	933	900	636	426	493	15	1050	1020	650	125	1285

Characteristic Curves

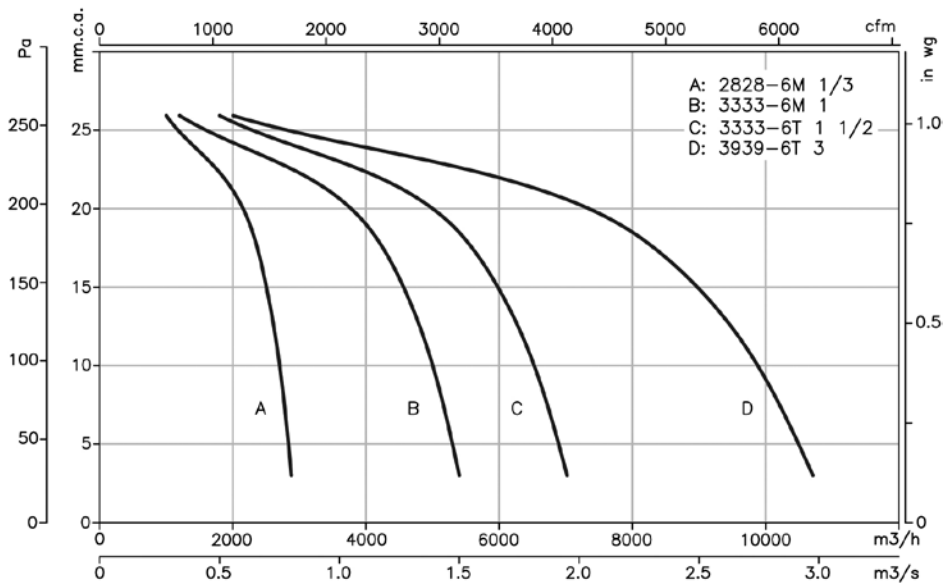
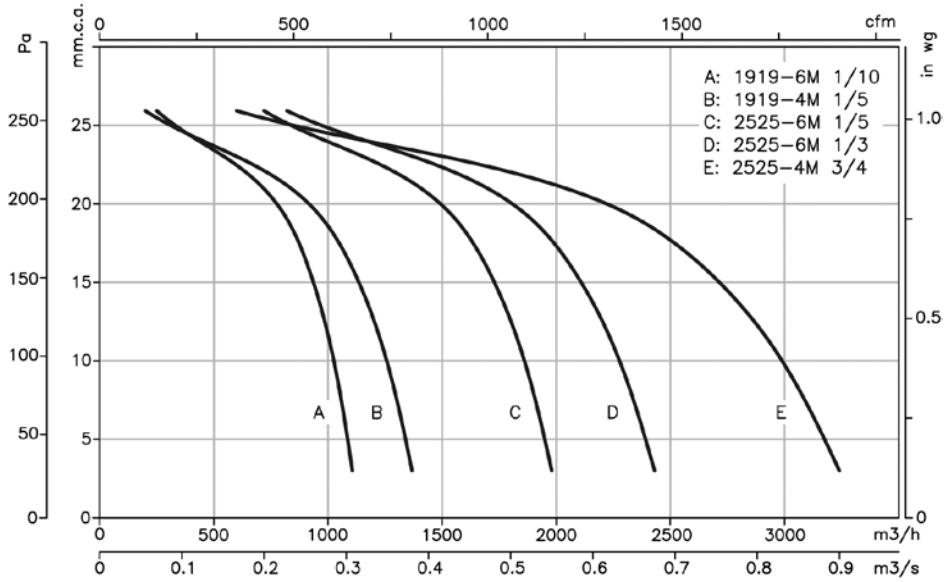

Accessories



TWIN

Soundproof ventilation units with expanded and fire-resistant polyethylene (M1), fitted with two fans for independent and alternative working, for installations where a reserve fan is necessary



Incorporates two independent fans

Fan:

- Galvanised sheet steel structure with thermal insulation and soundproofing
- Impeller with forward-facing blades made from galvanised sheet steel
- External terminal board to aid connection

Motor:

- Class F closed motors with incorporated thermal protector, ball bearings and IP54 protection
- Single-phase 220-240V. 50Hz, and Three-phase 220-240V./380-415V. 50Hz
- Max. temperature to transport -20°C. +60°C

Finish:

- Anticorrosive galvanized sheet steel.

On request:

- With circular inlet
- With ACO accessory mounted in the box

Order code

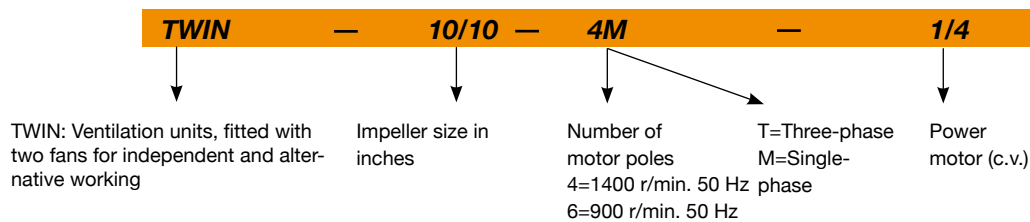

Technical characteristics

Model	Speed (r/min)	Maximum admissible current (A)		Installed Power (kW)	Maximum Airflow (m ³ /h)	Irradiated sound level (1) dB(A)	Approx. weight (Kg)
		230V	400V				
TWIN-7/7-4M 1/5	1200	1.50		0.15	1200	43	42.0
TWIN-7/7-6M 1/10	820	0.98		0.07	950	37	42.0
TWIN-9/9-4M 1/2	1380	3.80		0.37	2250	49	70.0
TWIN-9/9-4M 3/4	1250	4.00		0.55	2400	50	71.0
TWIN-9/9-6M 1/5	825	1.90		0.15	1500	41	66.0
TWIN-9/9-6M 1/3	835	2.40		0.25	1700	42	69.0
TWIN-10/10-4M 1/2	1380	3.80		0.37	1950	49	85.0
TWIN-10/10-4M 3/4	1250	4.00		0.55	3000	50	86.0
TWIN-10/10-6M 1/3	835	2.40		0.25	2300	41	84.0
TWIN-12/12-6T 1 1/2	900	6.60	3.80	1.10	5000	55	122.0
TWIN-12/12-6M 3/4	870	4.00		0.55	3700	48	119.0
TWIN-12/12-6M 1	900	6.50		0.75	4400	49	121.0
TWIN-15/15-6T3	850		5.50	2.20	8200	54	180.0

(1) The radiated sound pressure levels dB(A) are free field measurements at 2 metres.

Dimensions in mm

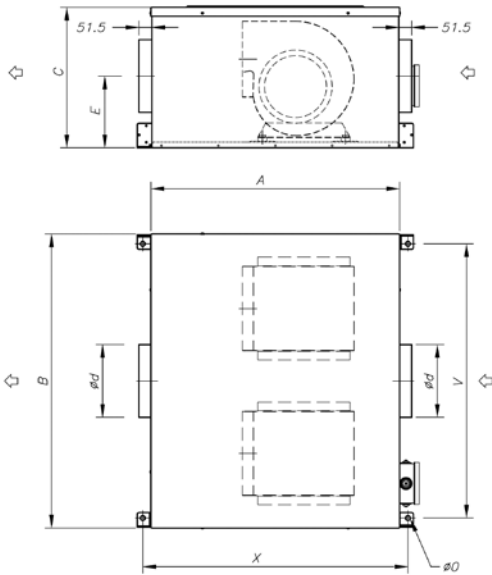

Model	A	B	C	ød	E	øO	X	V
TWIN-7/7	683	808	386	250	197	13	728.5	753.5
TWIN-9/9	833	1036	476	300	242	13	878.5	983
TWIN-10/10	945	1132	524	355	257	13	990.5	1079
TWIN-12/12	1103	1339	610	450	290	13	1148.5	1286
TWIN-15/15	1279	1639	698	500	344	13	1324.5	1586

Characteristic Curves

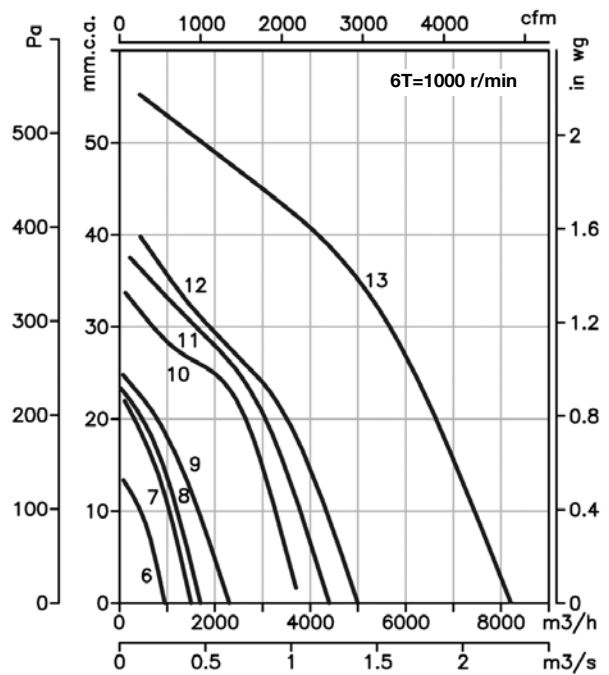
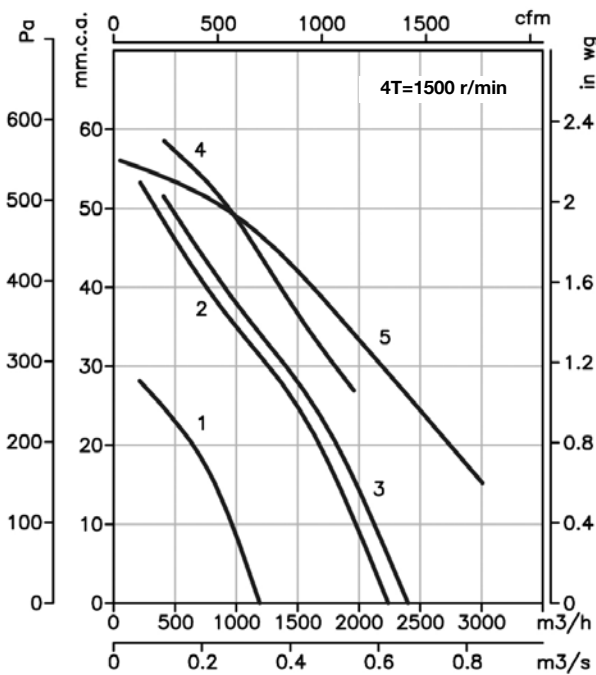

- | | |
|----------------------|------------------------|
| 1.TWIN-7/7-4M-0,2 | 8.TWIN-9/9-6M-0,33 |
| 2.TWIN-9/9-4M-0,5 | 9. TWIN-10/10-6M -0,33 |
| 3.TWIN-9/9-4M-0,75 | 10.TWIN-12/12-6M-0,75 |
| 4.TWIN-10/10-4M-0,5 | 11.TWIN-12/12-6M-1 |
| 5.TWIN-10/10-4M-0,75 | 12.TWIN-12/12-6T-1,5 |
| 6.TWIN-7/7-6M-0,1 | 13.TWIN-15/15-6T-3 |
| 7.TWIN-9/9-6M-0,2 | |

Accessories



ACO

CBX CBXC CBXR CBXT

CBX: Double-inlet, belt-driven centrifugal fans with axis outlet on both sides and impeller with forward-facing blades

CBXC: Double-inlet, belt-driven centrifugal fans with rigid cube structure to reinforce the casing

CBXR: Double-inlet, belt-driven centrifugal fans with reinforced structure and rigid bridge bearings supported on the structure

CBXT: Double-inlet, belt-driven centrifugal fans with electric motor, pulley, belt kit and standardised protectors and impeller with forward-facing blades



CBX

Fan:

- Galvanized sheet steel casing
- Impeller with forward-facing blades made from galvanised sheet steel
- CBX and CBXC: Bearing mounted with rubber vibration dampers
- CBX: They are supplied with CPS base stands

Motor:

- Motors with IE-2 efficiency, except for motors with lower powers than 0.75 kW, monophase motors or two-speed motors
- Free axis with permanently greased ball bearings at each end
- Max. air temperature to transport: CBX and CBXC: -20°C.+ 80°C. CBXR: -20°C.+ 110°C.

Finish:

- Anticorrosive galvanized sheet steel.

On request:

- CBX: Motor mounting bracket and SM belt tensing device can be supplied



CBXC



CBXR



CBXT

Order code

CBXC — 12/12



CBX: Centrifugal double-inlet fans with free axis outlet

Impeller size in inches

CBXC: Centrifugal double-inlet fans with cube structure

CBXR: Centrifugal double-inlet fans with reinforced structure

CBXT — 12/12 — 1,5



CBXT: Double-inlet, belt-driven centrifugal fans fitted with electric motor

Impeller size in inches

Power motor (c.v.)

Technical characteristics

Model	Max. Speed (r/min)	Equivalent Inches	Max. power installed (kW)	Maximum Airflow (m³/h)	Air temperature (°C)		Approx. weight (Kg)
					min.	max.	
CBX-1919	2500	7/7	1.1	3700	-20	+80	5.0
CBX-2525	1800	9/9	2.2	6200	-20	+80	9.0
CBX-2828	1700	10/10	3.0	7500	-20	+80	10.5
CBX-3333	1400	12/12	3.0	9500	-20	+80	15.5
CBX-3939	1000	15/15	4.0	14400	-20	+80	24.0
CBX-4747	800	18/18	5.5	23500	-20	+80	33.5
CBXC-7/7	2700		1,5	4200	-20	+80	6,0
CBXC-9/9	2100		3,0	7000	-20	+80	11,5
CBXC-10/10	1900		4,0	8400	-20	+80	13,5
CBXC-12/12	1600		4,0	10500	-20	+80	18,5
CBXC-15/15	1100		5,5	16000	-20	+80	27,5
CBXC-18/18	900		7,5	26000	-20	+80	38,5
CBXR-15/15	1200		5,5	16000	-20	80	28,5
CBXR-18/18	1000		7,5	26000	-20	80	40,0
CBXR-20/20	1000		11,0	28000	-20	+110	84,0
CBXR-22/22	900		15,0	34000	-20	+110	94,0
CBXR-25/25	700		15,0	46000	-20	+110	113,0
CBXR-30/28	600		18,5	60000	-20	+110	145,0

Model	Speed (r/min)	Maximum admissible current (A)			Installed Power (kW)	Maximum Airflow (m³/h)	Air temperature (°C)		Approx. weight (Kg)	Assembly Version
		230V	400V	690V			min.	max.		
CBXT-7/7-0,25	1090	1.1	0.64		0.18	1050	-20	+80	37.0	A
CBXT-7/7-0,33	1220	1.4	0.78		0.25	1100	-20	+80	37.8	A
CBXT-7/7-0,5	1420	1.8	1.05		0.37	1250	-20	+80	39.0	A
CBXT-7/7-0,75	1600	2.5	1.45		0.55	1450	-20	+80	41.0	A
CBXT-7/7-1	1790	3.3	1.90		0.75	1500	-20	+80	42.5	A
CBXT-9/9-0,25	825	1.1	0.64		0.18	1700	-20	+80	48.0	A
CBXT-9/9-0,33	920	1.4	0.78		0.25	1800	-20	+80	50.0	A
CBXT-9/9-0,5	1020	1.8	1.05		0.37	2200	-20	+80	51.5	A
CBXT-9/9-0,75	1050	2.5	1.45		0.55	2900	-20	+80	54.5	A
CBXT-9/9-1	1070	3.3	1.90		0.75	3200	-20	+80	56.0	A
CBXT-9/9-1,5	1260	4.5	2.59		1.10	3750	-20	+80	59.0	A
CBXT-10/10-0,5	845	1.8	1.05		0.37	2950	-20	+80	55.0	A
CBXT-10/10-0,75	845	2.5	1.45		0.55	3800	-20	+80	57.0	A
CBXT-10/10-1	960	3.3	1.90		0.75	4175	-20	+80	58.5	A
CBXT-10/10-1,5	1070	4.5	2.59		1.10	4800	-20	+80	61.3	A
CBXT-10/10-2	1140	6.0	3.45		1.50	5400	-20	+80	64.6	A
CBXT-12/12-0,5	595	1.8	1.05		0.37	4200	-20	+80	69.0	A
CBXT-12/12-0,75	675	2.5	1.45		0.55	4800	-20	+80	71.0	A
CBXT-12/12-1	765	3.3	1.90		0.75	5400	-20	+80	72.4	A
CBXT-12/12-1,5	855	4.5	2.59		1.10	5800	-20	+80	75.3	A
CBXT-12/12-2	965	6.0	3.45		1.50	6500	-20	+80	78.6	A
CBXT-12/12-3	1180	8.4	4.85		2.20	7400	-20	+80	87.0	A
CBXT-15/15-0,75	525	2.5	1.45		0.55	5900	-20	+80	85.0	B
CBXT-15/15-1	595	3.3	1.90		0.75	6500	-20	+80	86.4	B
CBXT-15/15-1,5	635	4.5	2.59		1.10	7500	-20	+80	89.3	B
CBXT-15/15-2	670	6.0	3.45		1.50	8200	-20	+80	92.6	B
CBXT-15/15-3	740	8.4	4.85		2.20	9500	-20	+80	101.0	B
CBXT-15/15-4	805	11.2	6.48		3.00	10600	-20	+80	103.0	B
CBXT-15/15-5.5	965	15.0	8.65		4.00	12000	-20	+80	108.0	B
CBXT-18/18-1.5	480	4.5	2.59		1.10	9000	-20	+80	122.0	B
CBXT-18/18-2	605	6.0	3.45		1.50	9250	-20	+80	125.3	B
CBXT-18/18-3	590	8.4	4.85		2.20	11500	-20	+80	133.7	B
CBXT-18/18-4	640	11.2	6.48		3.00	13200	-20	+80	135.7	B
CBXT-18/18-5,5	675	15.0	8.65		4.00	15000	-20	+80	141.0	B
CBXT-18/18-7,5	760		11.40	6.60	5.50	17000	-20	+80	154.5	B
CBXT-20/20-2	430	6.0	3.45		1.50	11500	-20	+80	222.0	B
CBXT-20/20-3	530	8.4	4.85		2.20	12800	-20	+80	230.5	B
CBXT-20/20-4	575	11.2	6.48		3.00	14200	-20	+80	232.5	B
CBXT-20/20-5,5	635	15.0	8.65		4.00	15500	-20	+80	237.5	B
CBXT-20/20-7,5	675		11.40	6.60	5.50	17500	-20	+80	251.5	B
CBXT-20/20-10	725		14.80	8.50	7.50	20000	-20	+80	266.5	B
CBXT-22/22-2	385	6.0	3.45		1.50	14000	-20	+80	250.0	B
CBXT-22/22-3	475	8.4	4.85		2.20	15000	-20	+80	257.0	B

Technical characteristics

Model	Speed (r/min)	Maximum admissible current (A)			Installed Power (kW)	Maximum Airflow (m³/h)	Air temperature (°C)		Approx. weight (Kg)	Assembly Version
		230V	400V	690V			min.	max.		
CBXT-22/22-4	515	11.2	6.48		3.00	17000	-20	+80	261.0	B
CBXT-22/22-5,5	570	15.0	8.65		4.00	19000	-20	+80	265.0	B
CBXT-22/22-7,5	605		11.40	6.60	5.50	21500	-20	+80	279.0	B
CBXT-22/22-10	725		14.80	8.50	7.50	22000	-20	+80	290.0	B
CBXT-22/22-15	765		21.00	12.10	11.00	27000	-20	+80	316.0	B
CBXT-25/25-3	375	8.4	4.85		2.20	17000	-20	+80	297.0	B
CBXT-25/25-4	405	11.2	6.48		3.00	20500	-20	+80	299.0	B
CBXT-25/25-5,5	450	15.0	8.65		4.00	22000	-20	+80	304.0	B
CBXT-25/25-7,5	485		11.40	6.60	5.50	24500	-20	+80	318.0	B
CBXT-25/25-10	545		14.80	8.50	7.50	28000	-20	+80	329.0	B
CBXT-25/25-15	610		21.00	12.10	11.00	32000	-20	+80	349.0	B
CBXT-30/28-3	330	8.4	4.85		2.20	20000	-20	+80	380.0	B
CBXT-30/28-4	360	11.2	6.48		3.00	22000	-20	+80	382.0	B
CBXT-30/28-5,5	380	15.0	8.65		4.00	25000	-20	+80	387.0	B
CBXT-30/28-7,5	380		11.40	6.60	5.50	31500	-20	+80	402.0	B
CBXT-30/28-10	410		14.80	8.50	7.50	36000	-20	+80	415.0	B
CBXT-30/28-15	430		21.00	12.10	11.00	42000	-20	+80	426.0	B
CBXT-30/28-20	480		28.50	16.50	15.00	48000	-20	+80	449.0	B

Dimensions in mm

CBX

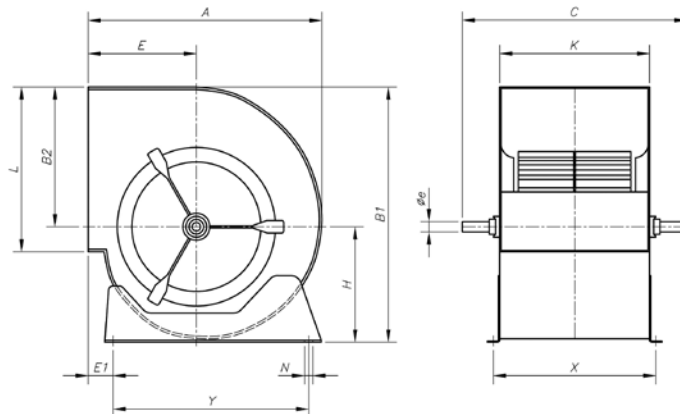

Model	Equiv. in inches	A	B1	B2	C	E	E1	H	K	L	N	øe	X	Y
CBX-1919	7/7	316	333	189	360	152	64	144	230	208	9x13	20	258	225
CBX-2525	9/9	380	400	218	430	183	78	182	300	263	9x13	20	328	275
CBX-2828	10/10	422	450	246	470	202	73	204	326	292	9x17	20	355	315
CBX-3333	12/12	493	526	290	560	230	82	236	387	345	9x17	25	415	390
CBX-3939	15/15	579	621	348	650	265	92	273	473	404	9x17	25	500	455
CBX-4747	18/18	686	746	415	750	323	82	331	540	482	9x17	25	568	575

CBXC

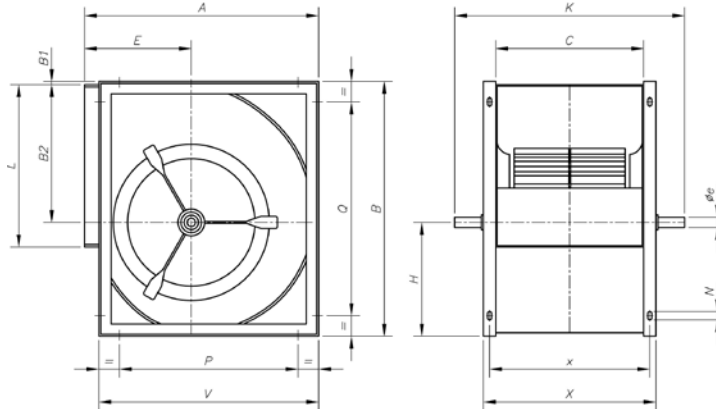

Model	A	B	B2	C	E	øe	H	K	L	N	P	Q	V	X	x
CBXC-7/7	322	342	189	230	152	20	153	360	208	9x17	148	175	292	290	262
CBXC-9/9	388	402	218	300	183	20	184	430	263	9x17	214	214	358	360	332
CBXC-10/10	428	450	246	326	202	20	204	470	292	9x17	254	254	398	386	358
CBXC-12/12	498	532	290	387	230	25	242	560	345	9x17	324	324	468	447	419
CBXC-15/15	583	632	348	473	265	25	284	650	404	9x17	406	406	553	533	505
CBXC-18/18	694	756	415	540	323	25	341	750	482	9x17	520	608	664	600	572

Dimensions in mm

CBXR

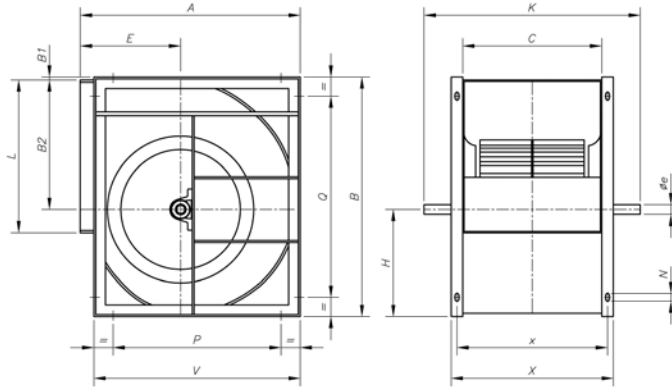

Model	A	B	B1	B2	C	E	øe	H	K	L	N	P	Q	V	X	x
CBXR-15/15	583	632	-	348	473	265	25	284	730	404	9x17	406	406	553	533	505
CBXR-18/18	694	756	-	415	540	323	25	341	800	482	9x17	520	608	664	600	572
CBXR-20/20	843	963	35	523	603	375	35	405	923	603	13x25	646	811	798	683	643
CBXR-22/22	913	1046	35	569	656	400	35	442	976	693	13x25	716	894	868	736	696
CBXR-25/25	998	1161	35	642	765	423	35	484	1085	793	13x25	801	1009	953	845	805
CBXR-30/28	1206	1400	35	776	888	515	40	589	1208	933	13x25	1009	1248	1161	968	928

CBXT
Installation A

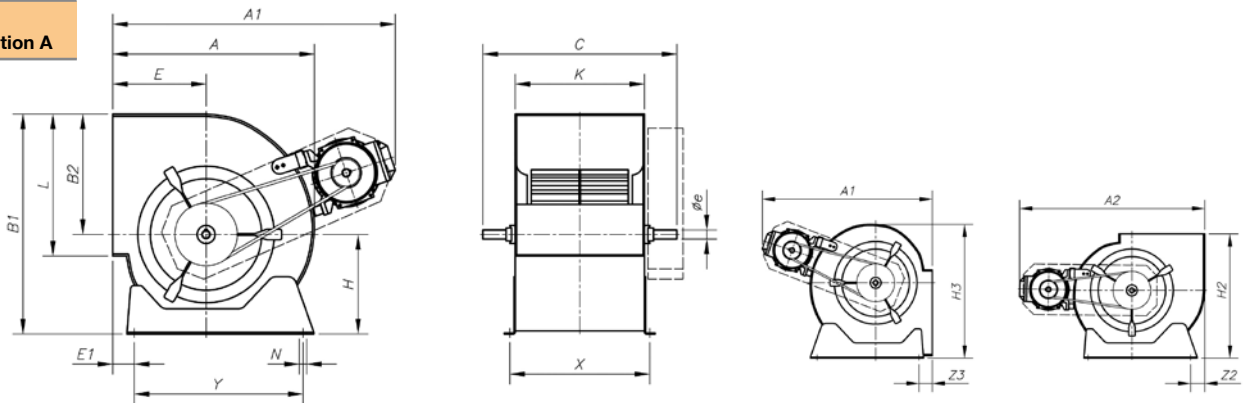

Model	A	A1	A2	B1	B2	C	E	E1	øe	H	H2	H3	K	L	N	X	Y	Z2	Z3
CBXT-7/7-0'25	316	430	475	333	189	360	152	64	20	144	320	341	230	208	9x13	258	225	44	36
CBXT-7/7-0'33	316	450	495	333	189	360	152	64	20	144	320	341	230	208	9x13	258	225	44	36
CBXT-7/7-0'5	316	450	495	333	189	360	152	64	20	144	320	341	230	208	9x13	258	225	44	36
CBXT-7/7-0'75	316	470	515	333	189	360	152	64	20	144	320	341	230	208	9x13	258	225	44	36
CBXT-7/7-1	316	470	515	333	189	360	152	64	20	144	320	341	230	208	9x13	258	225	44	36
CBXT-9/9-0'25	380	490	535	400	218	430	183	78	20	182	385	395	300	263	9x13	328	275	50	57
CBXT-9/9-0'33	380	520	565	400	218	430	183	78	20	182	385	395	300	263	9x13	328	275	50	57
CBXT-9/9-0'5	380	520	565	400	218	430	183	78	20	182	385	395	300	263	9x13	328	275	50	57
CBXT-9/9-0'75	380	540	585	400	218	430	183	78	20	182	385	395	300	263	9x13	328	275	50	57
CBXT-9/9-1	380	540	585	400	218	430	183	78	20	182	385	395	300	263	9x13	328	275	50	57
CBXT-9/9-1'5	380	590	605	400	218	430	183	78	20	182	385	395	300	263	9x13	328	275	50	57
CBXT-10/10-0'5	422	570	615	450	246	470	202	73	20	204	443	470	326	292	9x17	355	315	50	50
CBXT-10/10-0'75	422	590	635	450	246	470	202	73	20	204	443	470	326	292	9x17	355	315	50	50
CBXT-10/10-1	422	590	635	450	246	470	202	73	20	204	443	470	326	292	9x17	355	315	50	50
CBXT-10/10-1'5	422	610	655	450	246	470	202	73	20	204	443	470	326	292	9x17	355	315	50	50
CBXT-10/10-2	422	610	655	450	246	470	202	73	20	204	443	470	326	292	9x17	355	315	50	50
CBXT-12/12-0'5	493	645	690	526	290	560	230	82	25	236	498	555	387	345	9x17	415	390	35	70
CBXT-12/12-0'75	493	665	710	526	290	560	230	82	25	236	498	555	387	345	9x17	415	390	35	70
CBXT-12/12-1	493	665	710	526	290	560	230	82	25	236	498	555	387	345	9x17	415	390	35	70
CBXT-12/12-1'5	493	680	725	526	290	560	230	82	25	236	498	555	387	345	9x17	415	390	35	70
CBXT-12/12-2	493	680	725	526	290	560	230	82	25	236	498	555	387	345	9x17	415	390	35	70
CBXT-12/12-3	493	700	745	526	290	560	230	82	25	236	498	555	387	345	9x17	415	390	35	70

Dimensions in mm

CBXT Installation B

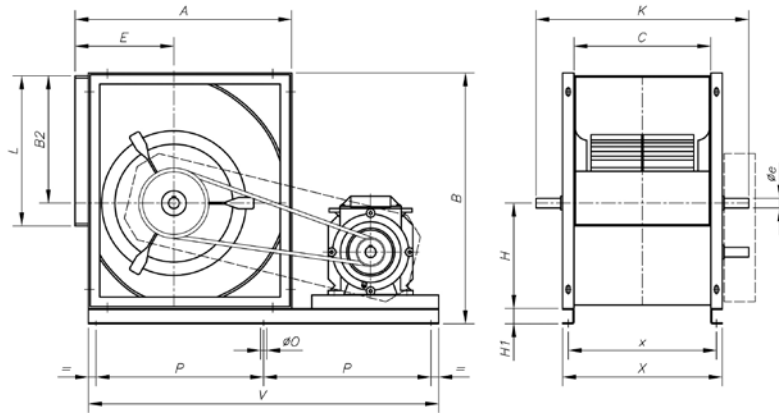

Model	A	B	B2	C	E	øe	H	H1	K	L	ø0	P	V	x	X
CBXT-15/15	583	672	348	473	265	25	284	40	650	404	12	415,5	895	505	533
CBXT-18/18	694	796	415	540	323	25	341	40	750	482	12	515,5	1115	572	600

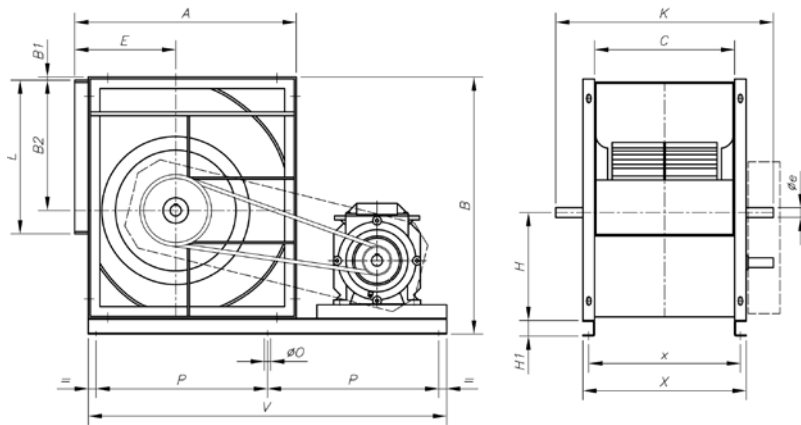

Model	A	B	B1	B2	C	E	øe	H	H1	K	L	ø0	P	V	x	X
CBXT-20/20	843	1023	35	523	603	375	35	405	60	923	603	12	617,5	1315	643	683
CBXT-22/22	913	1106	35	569	656	400	35	442	60	976	693	12	657,5	1395	696	736
CBXT-25/25	998	1221	35	642	765	423	35	484	60	1085	793	12	474,5	1575	805	845
CBXT-30/28	1206	1460	35	776	888	515	40	589	60	1208	933	12	817,5	1715	928	968

Characteristic Curves

Q = Airflow in m³/h, m³/s and cfm.

Pe = Static pressure in mm.w.c., Pa and in wg.

7/7 (1919)

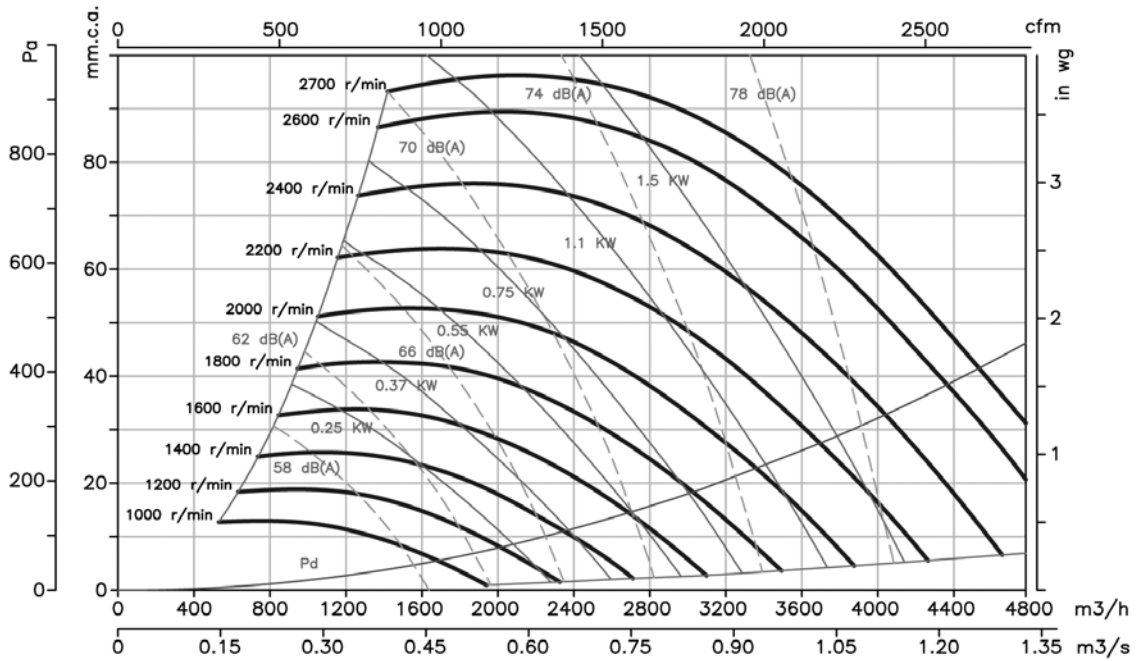

9/9 (2525)

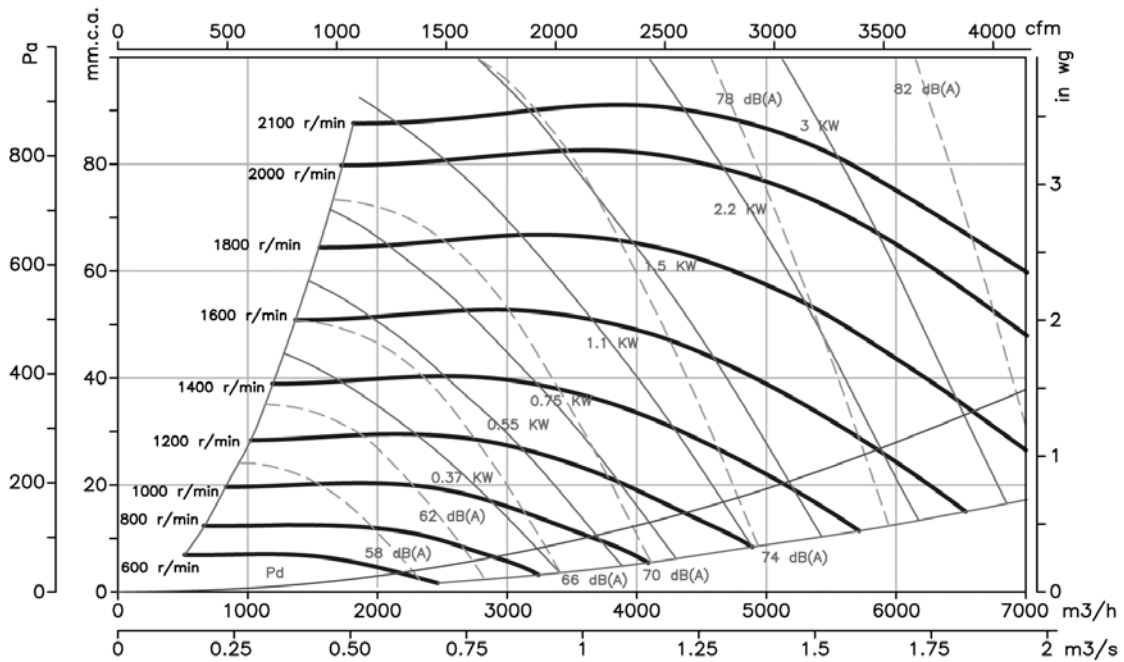

Characteristic Curves

Q = Airflow in m³/h, m³/s and cfm.

Pe = Static pressure in mm.w.c., Pa and in wg.

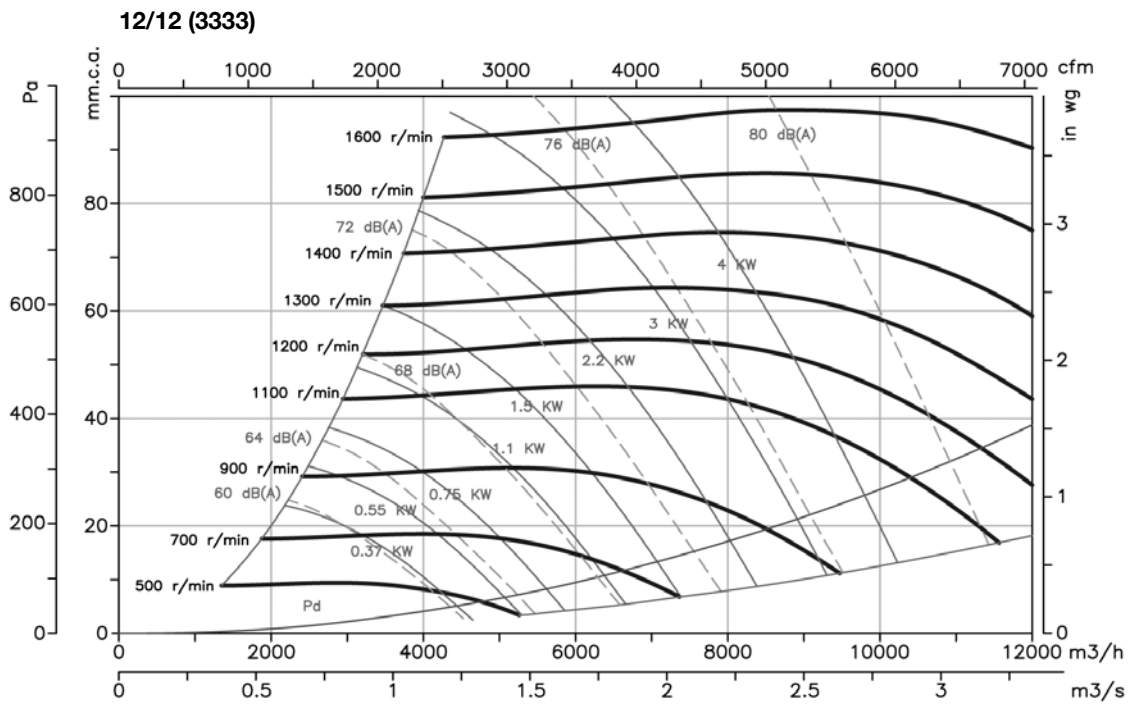
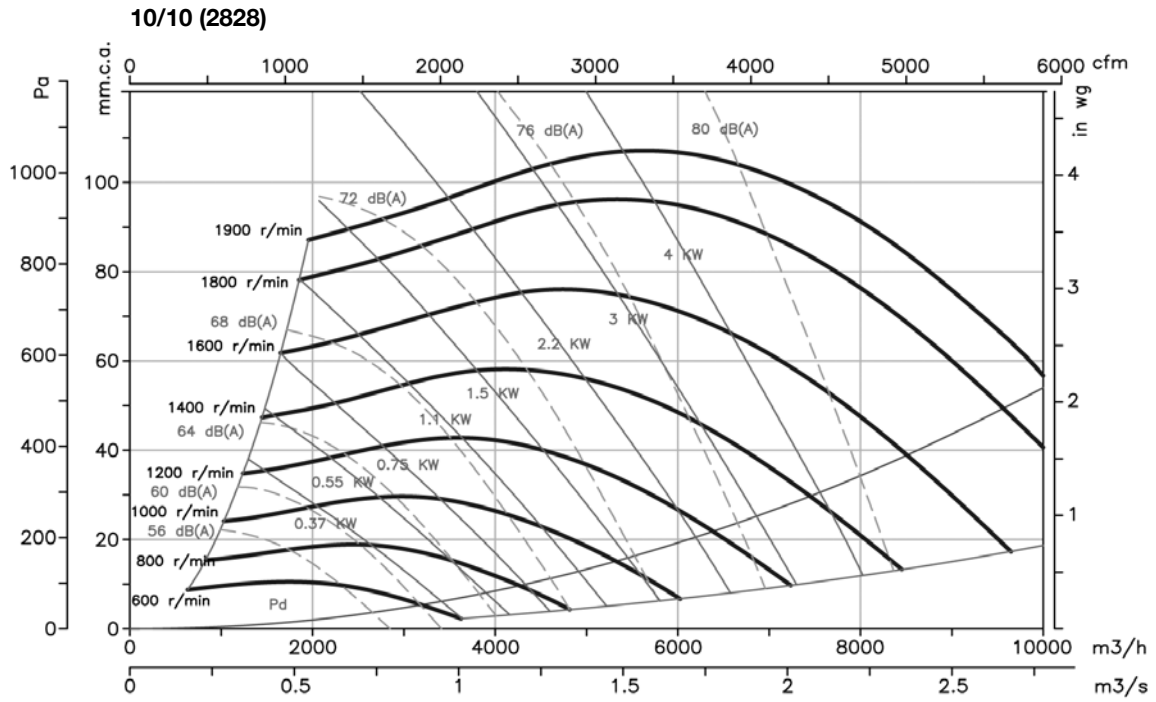

Characteristic Curves

Q = Airflow in m³/h, m³/s and cfm.

Pe = Static pressure in mm.w.c., Pa and in wg.

15/15 (3939)

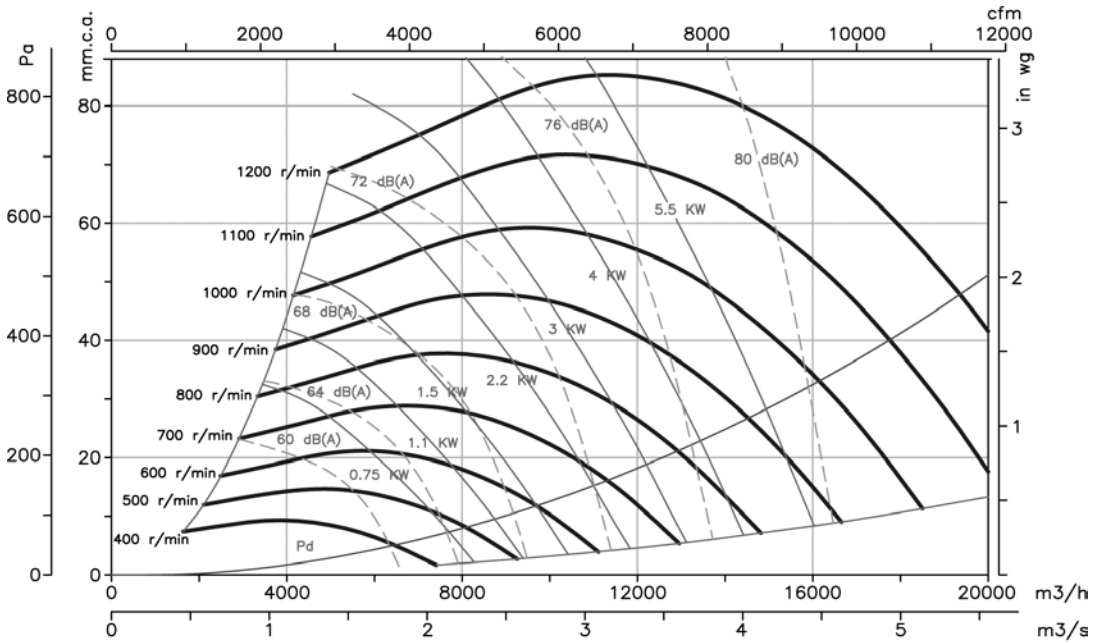

18/18 (4747)

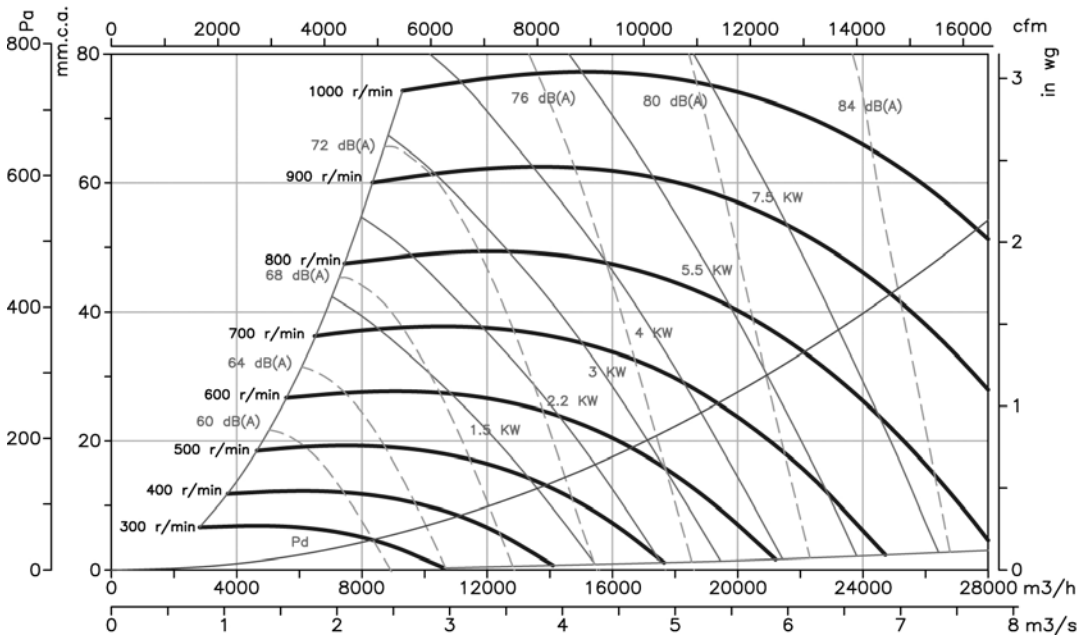

Characteristic Curves

Q = Airflow in m³/h, m³/s and cfm.

Pe = Static pressure in mm.w.c., Pa and in wg.

20/20

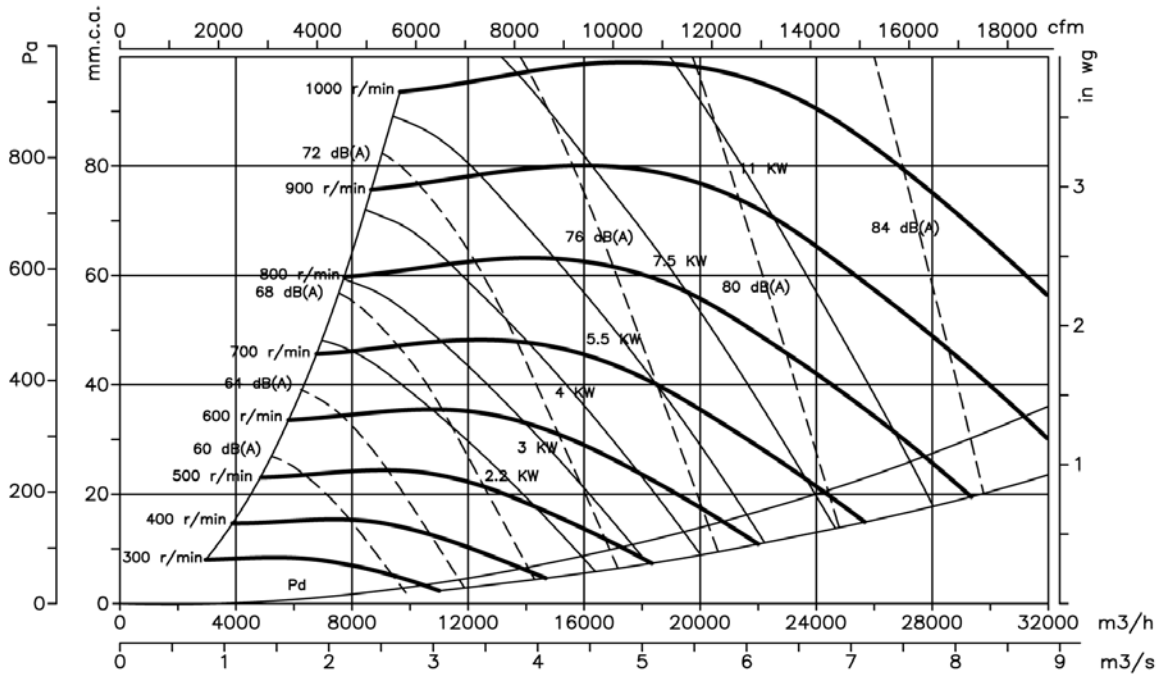

22/22

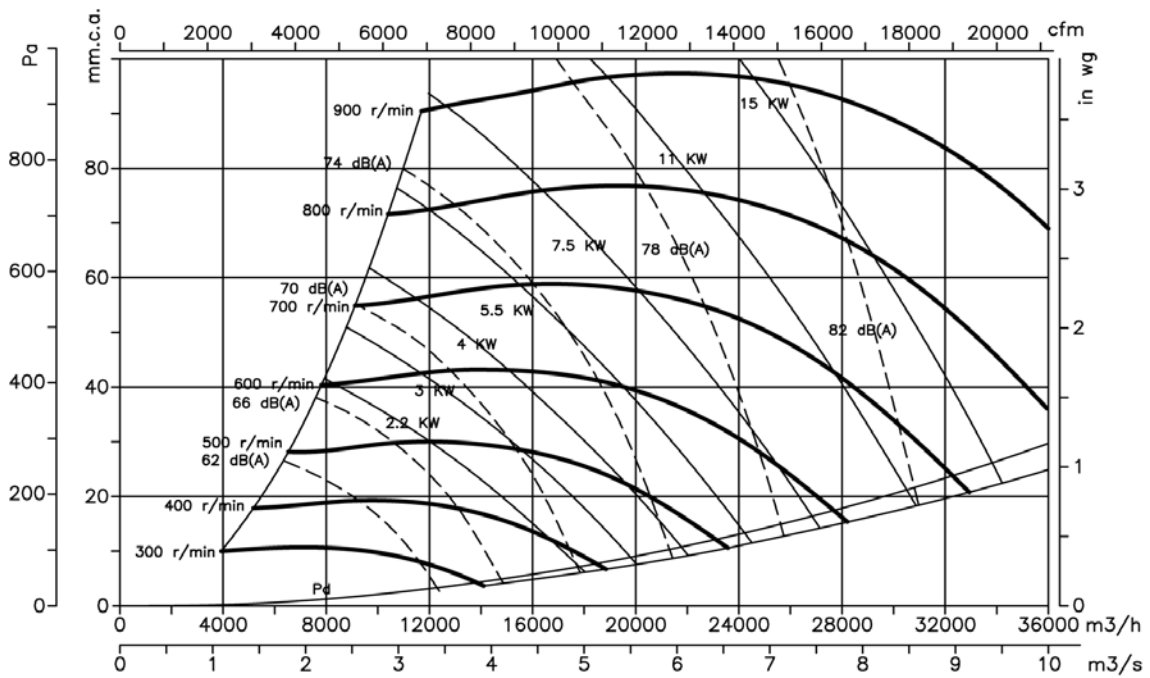

Characteristic Curves

Q = Airflow in m³/h, m³/s and cfm.

Pe = Static pressure in mm.w.c., Pa and in wg.

25/25

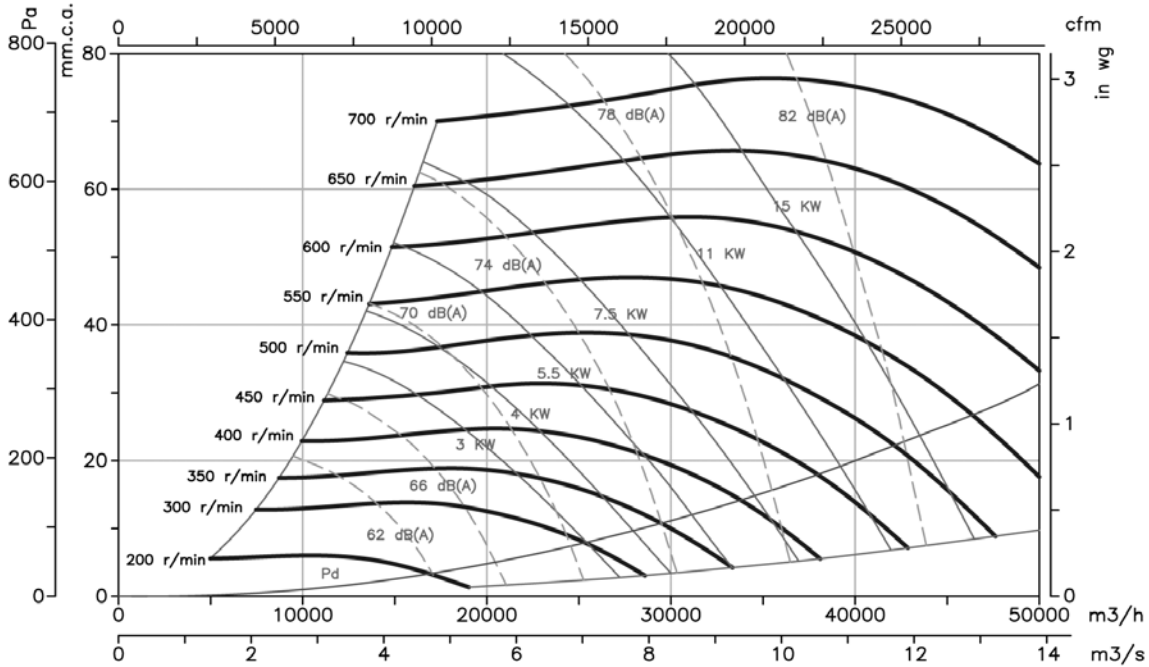

30/28

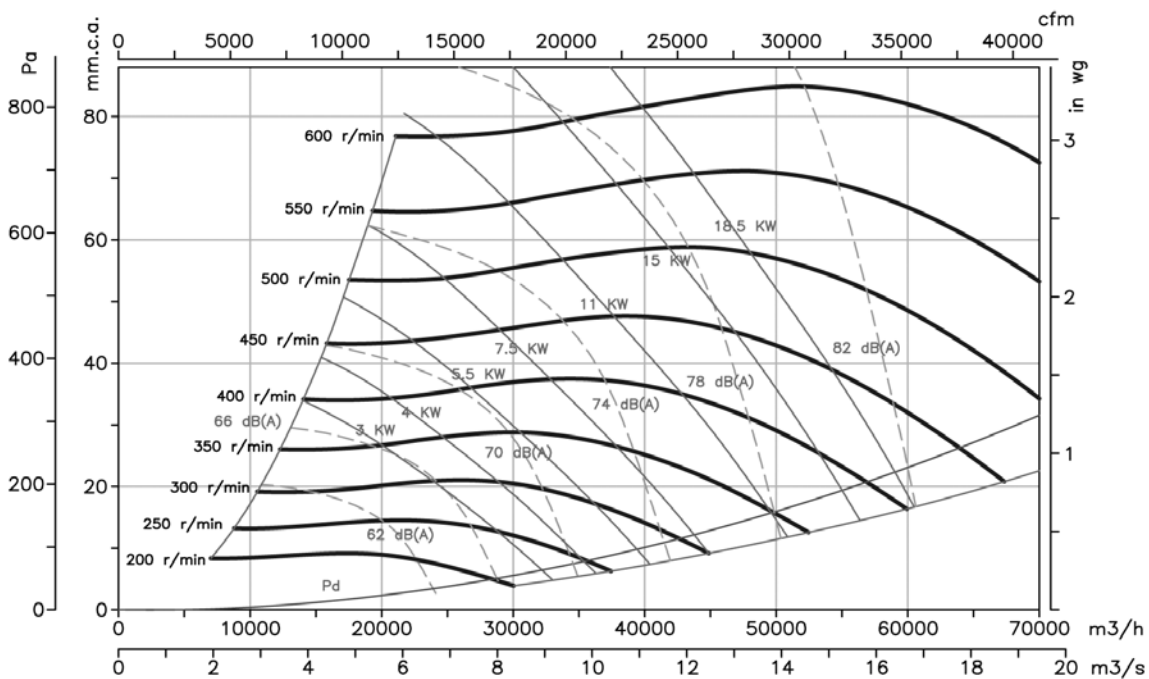

Accessories



CJBX CJBX/AL

CJBX: Soundproof belt-driven ventilation units fitted with double-inlet fans of the CBX, CBXC and CBXR series

CJBX/AL: Soundproof belt-driven ventilation units with aluminium profiles fitted with double-inlet fans of the CBX, CBXC and CBXR series



CJBX



CJBX/AL

Fan:

- Galvanised sheet steel structure with thermal insulation and soundproofing
- Impeller with forward-facing blades made from galvanised sheet steel
- Stuffing-box for cable input
- CJBX/AL: with aluminium profiles

Motor:

- Motors with IE-2 efficiency, except for motors with lower powers than 0.75 kW, monophase motors or two-speed motors
- Class F motors with ball bearings, IP55 protection
- Three-phase 230/400V.-50Hz. (up to 5.5CV.) and 400/690V.-50Hz. (power over 5.5CV.)
- Max. air temperature to transport: -20°C.+ 60°C.

Finish:

- Anticorrosive galvanized sheet steel.

On request:

- With circular inlet



High-quality, robust impeller, dynamically balanced in accordance with ISO-1940

Order code

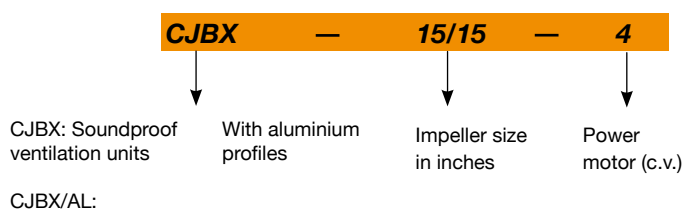

Technical characteristics

Model	Speed (r/min)	Maximum admissible current (A)			Installed Power (kW)	Maximum Airflow (m³/h)	Sound pressure level dB(A)	Approx. weight (Kg)	Type Assembly
		230V	400V	690V					
CJBX CJBX/AL 7/7-0,25	1090	1.1	0.64		0.18	1050	48	37.0	A
CJBX CJBX/AL 7/7-0,33	1220	1.4	0.78		0.25	1100	50	37.8	A
CJBX CJBX/AL 7/7-0,5	1420	1.8	1.05		0.37	1250	53	39.0	A
CJBX CJBX/AL 7/7-0,75	1600	2.5	1.45		0.55	1450	56	41.0	A
CJBX CJBX/AL 7/7-1	1790	3.3	1.90		0.75	1500	58	42.5	A
CJBX CJBX/AL 9/9-0,25	825	1.1	0.64		0.18	1700	45	48.0	A

Technical characteristics

Model	Speed (r/min)	Maximum admissible current (A)			Installed Power (kW)	Maximum Airflow (m³/h)	Sound pressure level dB(A)	Approx. weight (Kg)	Type Assembly
		230V	400V	690V					
CJBX CJBX/AL 9/9-0,33	920	1.4	0.78		0.25	1800	48	50.0	A
CJBX CJBX/AL 9/9-0,5	1020	1.8	1.05		0.37	2200	51	51.5	A
CJBX CJBX/AL 9/9-0,75	1050	2.5	1.45		0.55	2900	55	54.5	A
CJBX CJBX/AL 9/9-1	1070	3.3	1.90		0.75	3200	56	56.0	A
CJBX CJBX/AL 9/9-1,5	1260	4.5	2.59		1.10	3750	60	59.0	A
CJBX CJBX/AL 10/10-0,5	845	1.8	1.05		0.37	2950	52	55.0	A
CJBX CJBX/AL 10/10-0,75	845	2.5	1.45		0.55	3800	56	57.0	A
CJBX CJBX/AL 10/10-1	960	3.3	1.90		0.75	4175	58	58.5	A
CJBX CJBX/AL 10/10-1,5	1070	4.5	2.59		1.10	4800	61	61.3	A
CJBX CJBX/AL 10/10-2	1140	6.0	3.45		1.50	5400	63	64.6	A
CJBX CJBX/AL 12/12-0,5	595	1.8	1.05		0.37	4200	52	69.0	A
CJBX CJBX/AL 12/12-0,75	675	2.5	1.45		0.55	4800	54	71.0	A
CJBX CJBX/AL 12/12-1	765	3.3	1.90		0.75	5400	57	72.4	A
CJBX CJBX/AL 12/12-1,5	855	4.5	2.59		1.10	5800	59	75.3	A
CJBX CJBX/AL 12/12-2	965	6.0	3.45		1.50	6500	62	78.6	A
CJBX CJBX/AL 12/12-3	1180	8.4	4.85		2.20	7400	65	87.0	A
CJBX CJBX/AL 15/15-0,75	525	2.5	1.45		0.55	5900	49	85.0	A
CJBX CJBX/AL 15/15-1	595	3.3	1.90		0.75	6500	52	86.4	A
CJBX CJBX/AL 15/15-1,5	635	4.5	2.59		1.10	7500	54	89.3	A
CJBX CJBX/AL 15/15-2	670	6.0	3.45		1.50	8200	56	92.6	A
CJBX CJBX/AL 15/15-3	740	8.4	4.85		2.20	9500	59	101.0	A
CJBX CJBX/AL 15/15-4	805	11.2	6.48		3.00	10600	61	103.0	A
CJBX CJBX/AL 15/15-5,5	965	15.0	8.65		4.00	12000	63	108.0	B
CJBX CJBX/AL 18/18-1,5	480	4.5	2.59		1.10	9000	48	122.0	A
CJBX CJBX/AL 18/18-2	605	6.0	3.45		1.50	9250	51	125.3	A
CJBX CJBX/AL 18/18-3	590	8.4	4.85		2.20	11500	54	133.7	A
CJBX CJBX/AL 18/18-4	640	11.2	6.48		3.00	13200	56	135.7	B
CJBX CJBX/AL 18/18-5,5	675	15.0	8.65		4.00	15000	58	141.0	B
CJBX CJBX/AL 18/18-7,5	760		11.40	6.60	5.50	17000	60	154.5	B
CJBX CJBX/AL 20/20-2	430	6.0	3.45		1.50	11500	56	222.0	B
CJBX CJBX/AL 20/20-3	530	8.4	4.85		2.20	12800	57	230.5	B
CJBX CJBX/AL 20/20-4	575	11.2	6.48		3.00	14200	58	232.5	B
CJBX CJBX/AL 20/20-5,5	635	15.0	8.65		4.00	15500	61	237.5	B
CJBX CJBX/AL 20/20-7,5	675		11.40	6.60	5.50	17500	63	251.5	B
CJBX CJBX/AL 20/20-10	725		14.80	8.50	7.50	20000	65	266.5	B
CJBX CJBX/AL 22/22-2	385	6.0	3.45		1.50	14000	50	250.0	B
CJBX CJBX/AL 22/22-3	475	8.4	4.85		2.20	15000	54	257.0	B
CJBX CJBX/AL 22/22-4	515	11.2	6.48		3.00	17000	55	261.0	B
CJBX CJBX/AL 22/22-5,5	570	15.0	8.65		4.00	19000	57	265.0	B
CJBX CJBX/AL 22/22-7,5	605		11.40	6.60	5.50	21500	60	279.0	B
CJBX CJBX/AL 22/22-10	725		14.80	8.50	7.50	22000	63	290.0	B
CJBX CJBX/AL 22/22-15	765		21.00	12.10	11.00	27000	65	316.0	B
CJBX CJBX/AL 25/25-3	375	8.4	4.85		2.20	17000	53	297.0	B
CJBX CJBX/AL 25/25-4	405	11.2	6.48		3.00	20500	55	299.0	B
CJBX CJBX/AL 25/25-5,5	450	15.0	8.65		4.00	22000	57	304.0	B
CJBX CJBX/AL 25/25-7,5	485		11.40	6.60	5.50	24500	59	318.0	B
CJBX CJBX/AL 25/25-10	545		14.80	8.50	7.50	28000	61	329.0	B
CJBX CJBX/AL 25/25-15	610		21.00	12.10	11.00	32000	64	349.0	B
CJBX CJBX/AL 30/28-3	330	8.4	4.85		2.20	20000	54	380.0	B
CJBX CJBX/AL 30/28-4	360	11.2	6.48		3.00	22000	56	382.0	B
CJBX CJBX/AL 30/28-5,5	380	15.0	8.65		4.00	25000	59	387.0	B
CJBX CJBX/AL 30/28-7,5	380		11.40	6.60	5.50	31500	60	402.0	B
CJBX CJBX/AL 30/28-10	410		14.80	8.50	7.50	36000	63	415.0	B
CJBX CJBX/AL 30/28-15	430		21.00	12.10	11.00	42000	65	426.0	B
CJBX CJBX/AL 30/28-20	480		28.50	16.50	15.00	48000	68	449.0	B

Dimensions in mm

CJBX

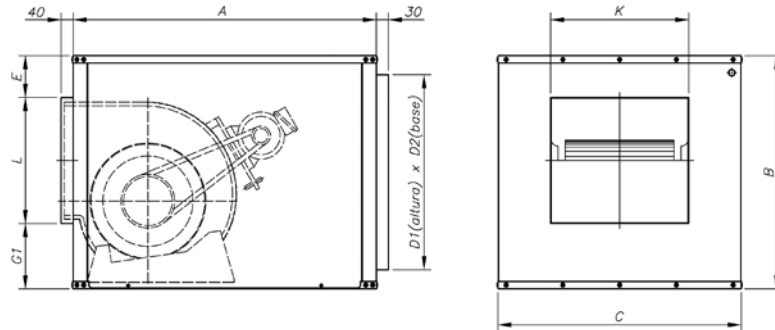

Installation A

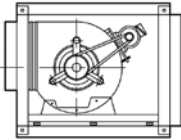

Installation B

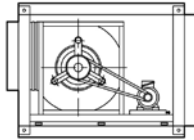

Model	A	B	C	D1xD2	E	G1	L	K
CJBX-7/7	650	460	500	364x404	114	142	204	226
CJBX-9/9	700	522	550	426x454	108,5	157,5	256	296
CJBX-10/10	750	575	600	479x504	107	182	286	322
CJBX-12/12	850	650	700	554x604	95	214	341	383
CJBX-15/15	1000	755	800	659x704	74	277	404	471
CJBX-18/18	1200	875	1000	779x904	57,5	337,5	480	537
CJBX-20/20	1400	1175	1100	1079x1004	147	428	600	600
CJBX-22/22	1460	1250	1250	1154x1154	145	413	692	653
CJBX-25/25	1550	1375	1450	1279x1354	152	431	792	762
CJBX-30/28	1800	1600	1650	1504x1554	140	528	932	885

CJBX vertical impulsion

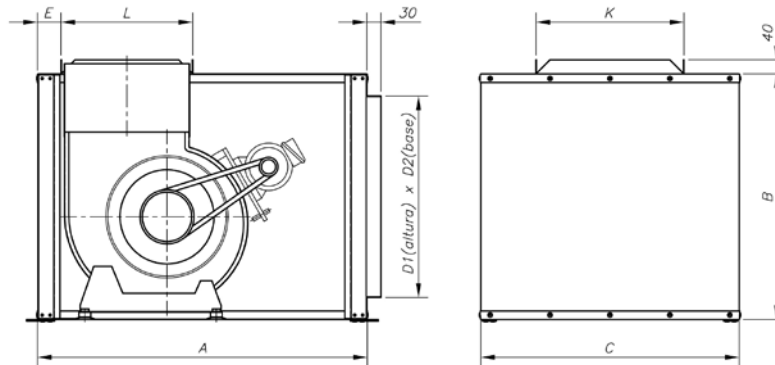

Installation A

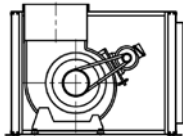

Installation B

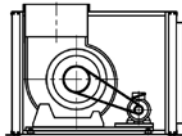

Model	A	B	C	D1xD2	E	L	K
CJBX-7/7	650	460	500	364x404	30	204	226
CJBX-9/9	700	522	550	426x454	30	256	296
CJBX-10/10	750	575	600	479x504	30	286	322
CJBX-12/12	850	650	700	554x604	30	341	383
CJBX-15/15	1000	755	800	659x704	30	404	471
CJBX-18/18	1200	875	1000	779x904	30	484	537
CJBX-20/20	1445	1175	1100	1079x1004	60	600	600
CJBX-22/22	1580	1250	1250	1154x1154	60	692	653
CJBX-25/25	1675	1375	1450	1279x1354	60	792	762
CJBX-30/28	1935	1600	1650	1504x1554	60	932	885

Dimensions in mm

CJBX/AL

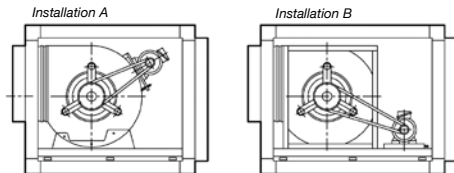
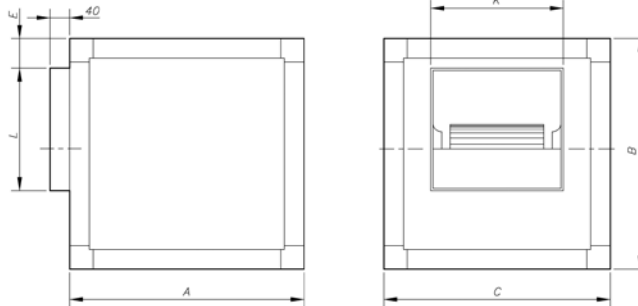

Model	A	B	C	E	L	K
CJBX/AL-7/7	650	460	460	75	216	238
CJBX/AL-9/9	700	520	520	75	268	305
CJBX/AL-10/10	750	575	575	75	296	330
CJBX/AL-12/12	850	650	650	75	346	390
CJBX/AL-15/15	1000	755	755	85	411	482
CJBX/AL-18/18	1200	1000	1000	185	491	550
CJBX/AL-20/20	1400	1170	1250	143	620	618
CJBX/AL-22/22	1480	1230	1300	127,5	711	681
CJBX/AL-25/25	1600	1350	1500	114	810	781
CJBX/AL-30/28	1850	1600	1700	125	949	906

CJBX/AL vertical impulsion

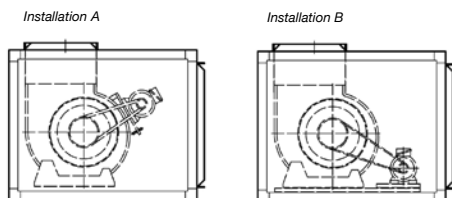
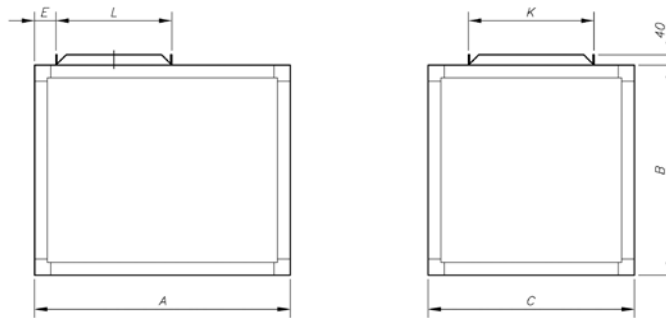

Model	A	B	C	E	L	K
CJBX/AL-7/7	650	460	460	75	216	238
CJBX/AL-9/9	700	520	520	75	268	305
CJBX/AL-10/10	750	575	575	75	296	330
CJBX/AL-12/12	850	650	650	75	346	390
CJBX/AL-15/15	1000	755	755	85	411	482
CJBX/AL-18/18	1200	1000	1000	185	491	550
CJBX/AL-20/20	1400	1170	1250	349,5	620	618
CJBX/AL-22/22	1480	1230	1300	342,5	711	681
CJBX/AL-25/25	1600	1350	1500	366,5	810	781
CJBX/AL-30/28	1850	1600	1700	459,5	949	906

Characteristic Curves

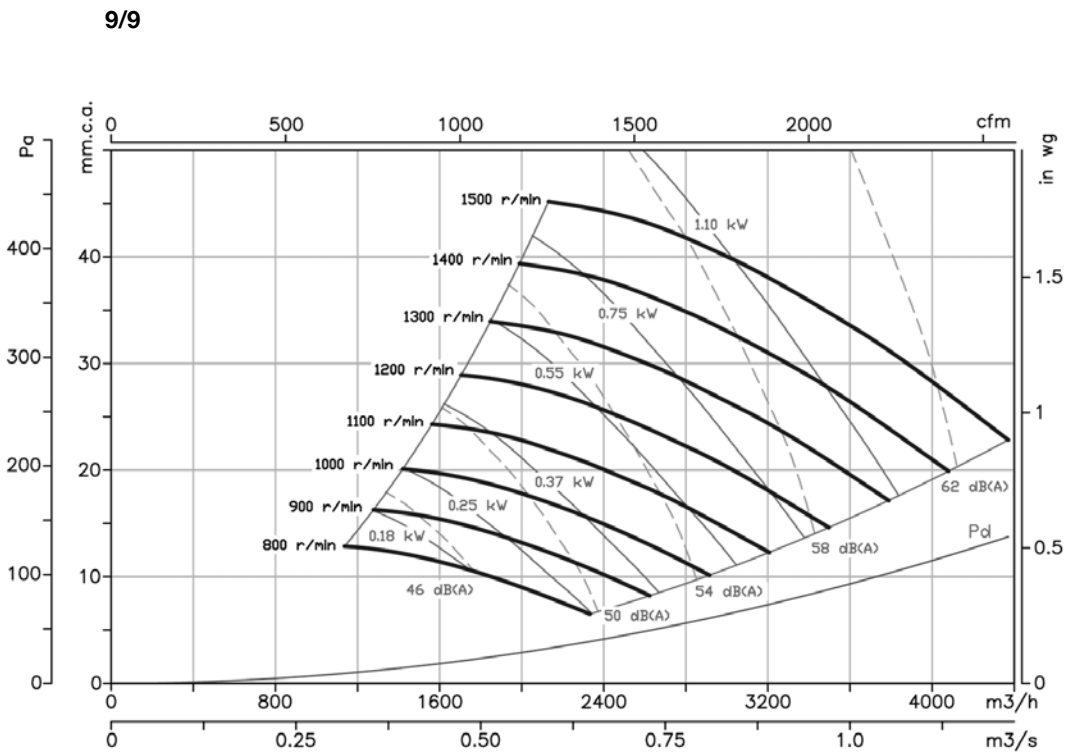
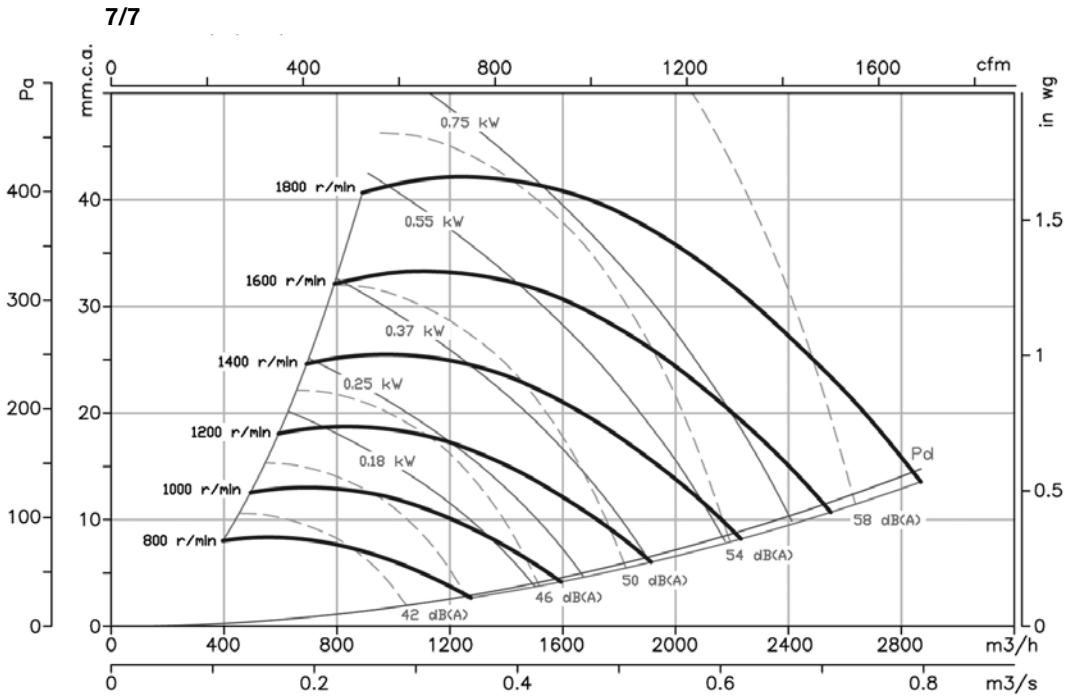

Characteristic Curves

Q = Airflow in m³/h, m³/s and cfm.

Pe = Static pressure in mm.w.c., Pa and in wg.

10/10

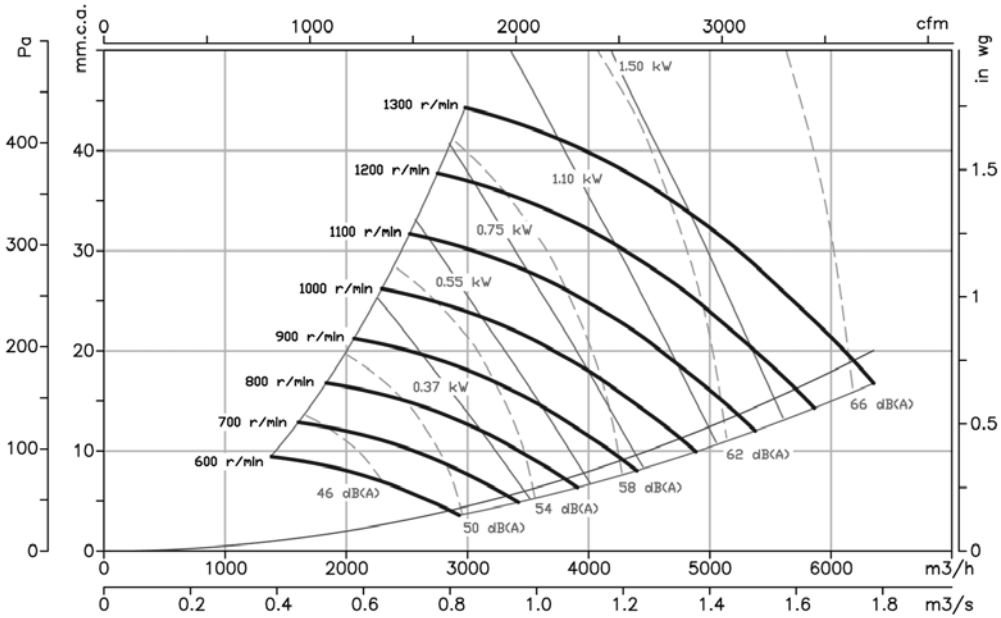

12/12

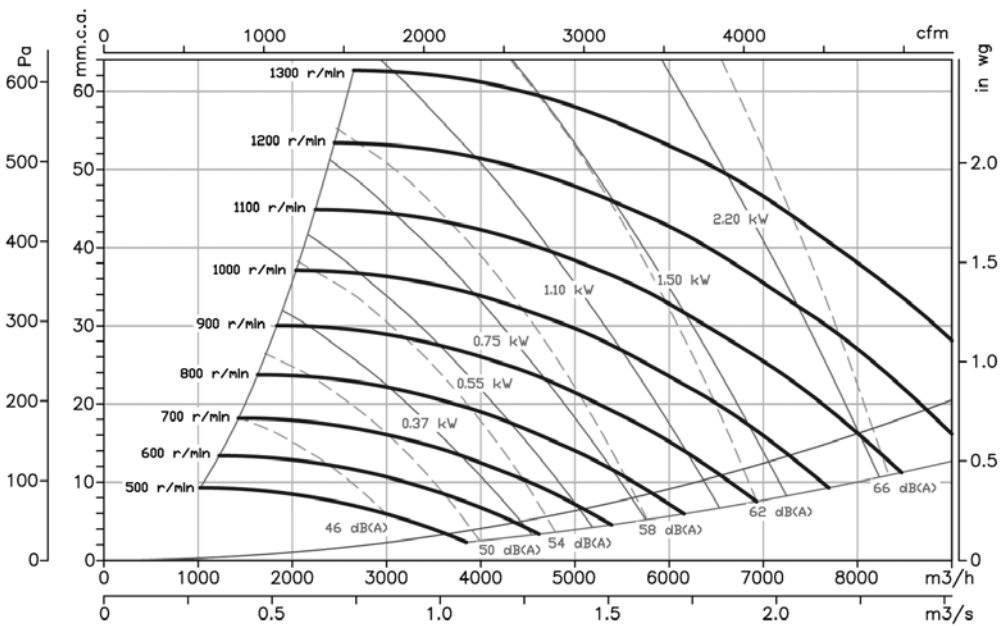

Characteristic Curves

Q = Airflow in m³/h, m³/s and cfm.

Pe= Static pressure in mm.w.c., Pa and in wg.

15/15

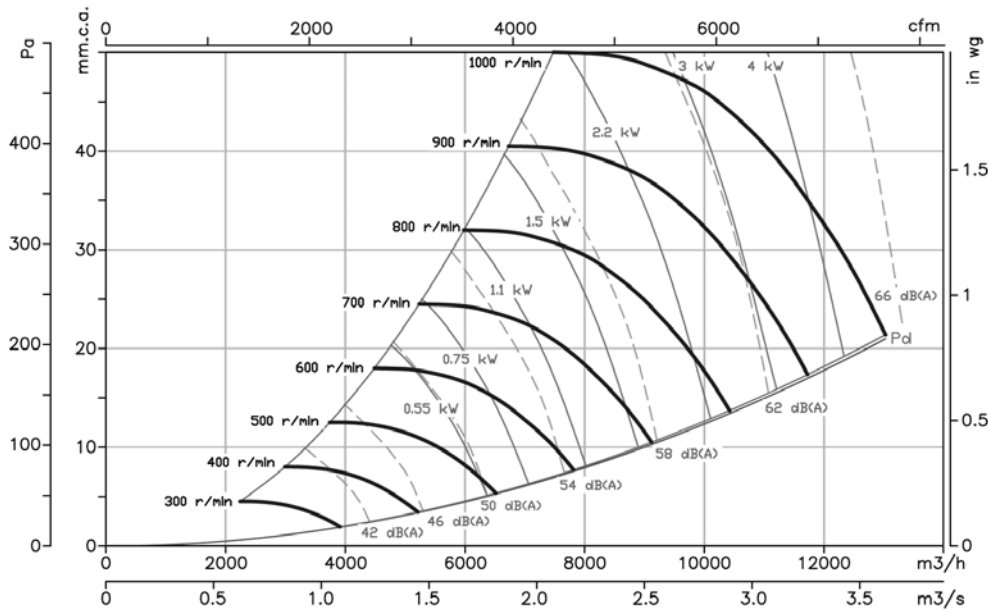

18/18

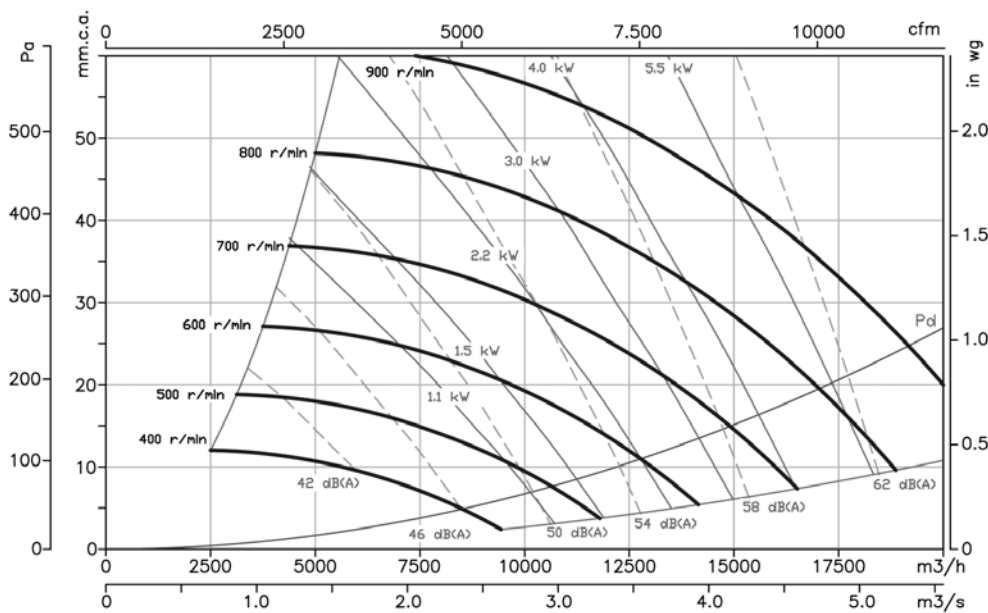

Characteristic Curves

20/20

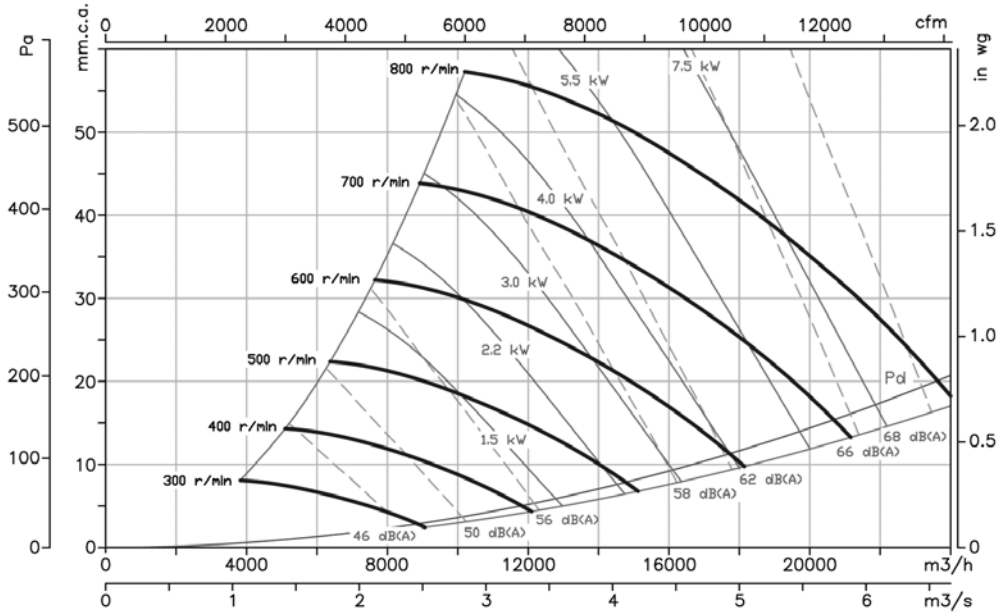

22/22

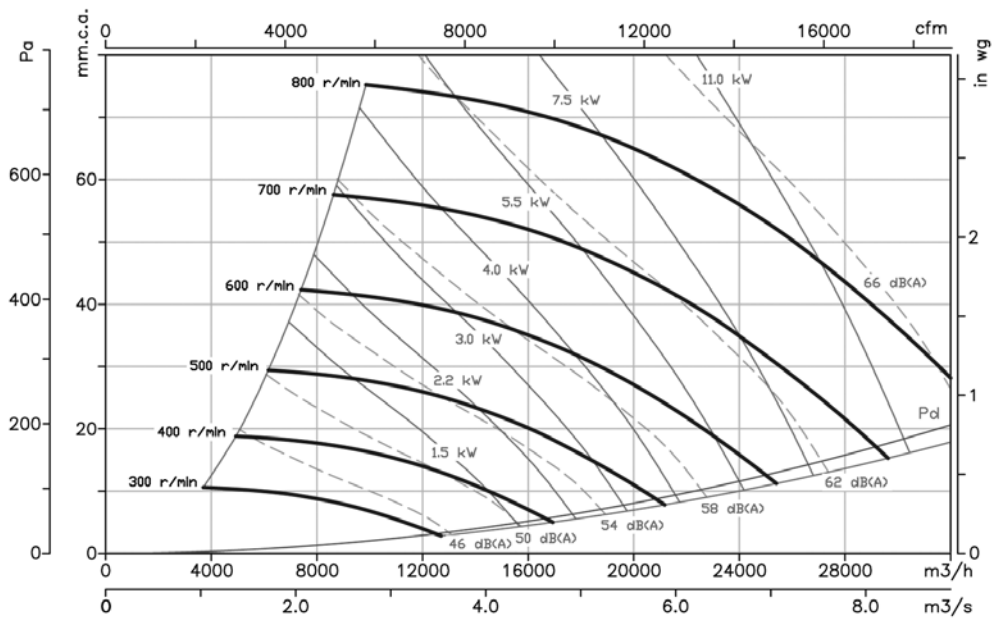

Characteristic Curves

Q = Airflow in m³/h, m³/s and cfm.

Pe= Static pressure in mm.w.c., Pa and in wg.

25/25

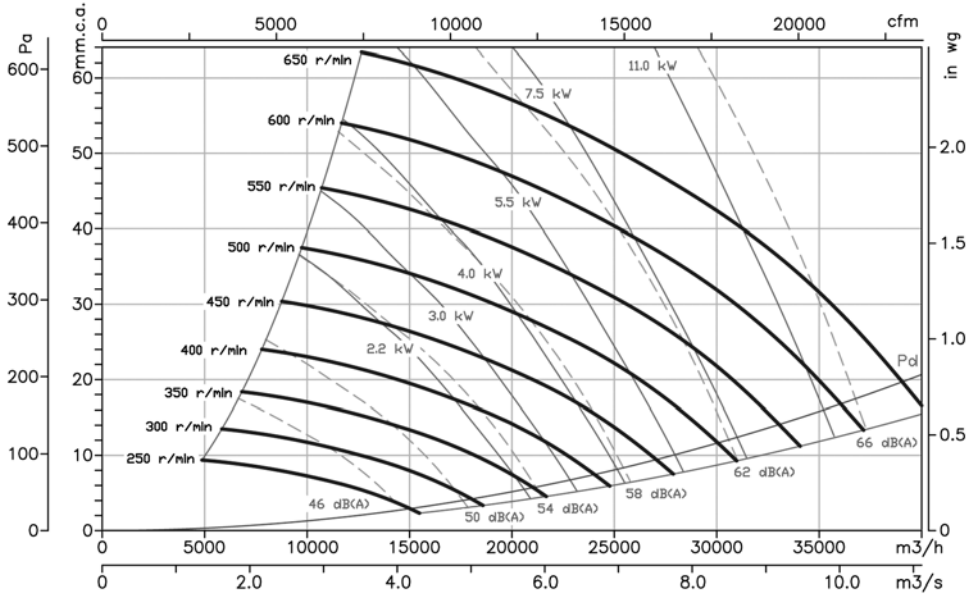

30/28

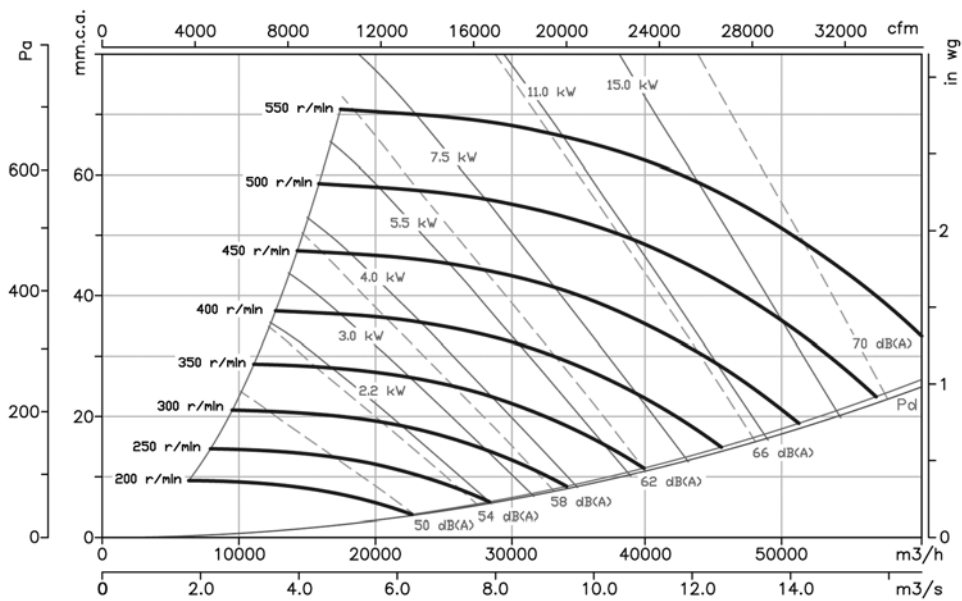

Accessories



INT

C2V

RM

AR

RFT

AET

VIS

TEJ

TSA TSAT CJTSA

TSA: Single-inlet, belt-driven centrifugal fans with axis outlet and impeller with forward-facing blades

TSAT: Single-inlet, belt-driven centrifugal fans with electric motor, pulley, belt kit and standardised protectors and impeller with forward-facing blades.

CJTSA: Soundproof ventilation units with forward-facing blades, fitted with TSA series fans on rubber dampers



TSA



TSAT



CJTSA

Fan:

- Galvanized sheet steel casing
- Impeller with forward-facing blades made from galvanised sheet steel
- Galvanised sheet steel structure with thermal insulation and soundproofing (CJTSA)
- Stuffing-box for cable input (CJTSA)

Motor:

- Motors with IE-2 efficiency, except for motors with lower powers than 0.75 kW, monophase motors or two-speed motors
- Class F motors with ball bearings, IP55 protection
- Three-phase 230/400V, 50Hz (up to 5.5CV) and 400/690V, 50Hz (power over 5.5CV)
- Max. air temperature to transport: -20°C. +60°C.

Finish:

- Anticorrosive galvanized sheet steel.

On request:

- Different outlet positions
- Special windings for different voltages
- With 2 speed motors

Order code

TSA — 22/11



TSA: Centrifugal single-inlet fans with free axis outlet

Impeller size

CJTSA — 22/11 — 3



TSAT: Centrifugal single-inlet fans with electric motor

CJTSA: Ventilation units with impeller with forward-facing blades

Impeller size in inches

Power motor (c.v.)

Technical characteristics

Model	Max. Speed (r/min)	Max. Power installed (kW)	Maximum Airflow (m³/h)	Air temperature (°C)		Approx. weight (Kg)
				min.	max.	
TSA-12/6	1500	2.2	4800	-20	85	17.5
TSA-15/7	1050	3	7400	-20	85	22.5
TSA-18/9	920	4	10500	-20	85	33
TSA-20/10	850	5.5	15000	-20	85	71
TSA-22/11	1000	18.5	26000	-20	85	80
TSA-25/13	810	18.5	32000	-20	85	93
TSA-30/14	600	18.5	38000	-20	85	125

Technical characteristics

Model	Speed (r/min)	Maximum admissible current (A)			Installed Power (kW)	Maximum Airflow (m³/h)	Sound pressure level dB(A)	Approx. weight (Kg)
		230V	400V	690V				
TSAT CJTSA 12/6-0,75	1000	2.4	1.4		0.55	2600	69	73
TSAT CJTSA 12/6-1	1100	3.3	1.9		0.75	3100	71	74
TSAT CJTSA 12/6-1,5	1250	4.5	2.6		1.1	3500	74	77
TSAT CJTSA 12/6-2	1300	6.0	3.5		1.5	4250	77	80
TSAT CJTSA 12/6-3	1500	8.3	4.8		2.2	4800	79	85
TSAT CJTSA 15/7-1	800	3.3	1.9		0.75	4000	67	92
TSAT CJTSA 15/7-1,5	850	4.5	2.6		1.1	4800	69	95
TSAT CJTSA 15/7-2	920	6.0	3.5		1.5	5400	72	98
TSAT CJTSA 15/7-3	1000	8.3	4.8		2.2	6400	75	103
TSAT CJTSA 15/7-4	1050	11.2	6.5		3	7400	77	106
TSAT CJTSA 18/9-1,5	750	4.5	2.6		1.1	5800	68	111
TSAT CJTSA 18/9-2	790	6.0	3.5		1.5	6600	70	114
TSAT CJTSA 18/9-3	800	8.3	4.8		2.2	8200	74	119
TSAT CJTSA 18/9-4	850	11.2	6.5		3	9000	76	122
TSAT CJTSA 18/9-5,5	920	14.9	8.6		4	10500	78	125
TSAT CJTSA 20/10-2	650	6.0	3.5		1.5	8100	65	203
TSAT CJTSA 20/10-3	690	8.3	4.8		2.2	10100	68	208
TSAT CJTSA 20/10-4	750	11.2	6.5		3	11500	70	211
TSAT CJTSA 20/10-5,5	790	14.9	8.6		4	13100	73	214
TSAT CJTSA 20/10-7,5	850		11.1	6.4	5.5	15000	75	227
TSAT CJTSA 22/11-3	580	8.3	4.8		2.2	11200	67	219
TSAT CJTSA 22/11-4	610	11.2	6.5		3	13000	70	222
TSAT CJTSA 22/11-5,5	650	14.9	8.6		4	15000	72	225
TSAT CJTSA 22/11-7,5	690		11.1	6.4	5.5	17000	74	238
TSAT CJTSA 22/11-10	750		14.8	8.5	7.5	19000	76	246
TSAT CJTSA 22/11-12,5	790		17.8	10.3	9.2	21000	78	257
TSAT CJTSA 22/11-15	830		21.5	12.4	11	22000	79	273
TSAT CJTSA 22/11-20	910		28.5	16.5	15	24500	81	292
TSAT CJTSA 22/11-25	1000		35.0	20.2	18.5	26000	83	322
TSAT CJTSA 25/13-4	520	11.2	6.5		3	14000	62	254
TSAT CJTSA 25/13-5,5	550	14.9	8.6		4	17000	65	257
TSAT CJTSA 25/13-7,5	590		11.1	6.4	5.5	19500	67	270
TSAT CJTSA 25/13-10	620		14.8	8.5	7.5	23000	70	278
TSAT CJTSA 25/13-12,5	650		17.8	10.3	9.2	25000	72	289
TSAT CJTSA 25/13-15	690		21.5	12.4	11	26500	74	305
TSAT CJTSA 25/13-20	750		28.5	16.5	15	29500	75	324
TSAT CJTSA 25/13-25	810		35.0	20.2	18.5	32000	77	354
TSAT CJTSA 30/14-5,5	400	14.9	8.6		4	21000	69	331
TSAT CJTSA 30/14-7,5	425		11.1	6.4	5.5	24000	72	344
TSAT CJTSA 30/14-10	460		14.8	8.5	7.5	27500	74	352
TSAT CJTSA 30/14-12,5	480		17.8	10.3	9.2	30000	76	363
TSAT CJTSA 30/14-15	500		21.5	12.4	11	33000	77	379
TSAT CJTSA 30/14-20	550		28.5	16.5	15	36500	78	398
TSAT CJTSA 30/14-25	600		35.0	20.2	18.5	38000	81	428

Dimensions in mm

TSA

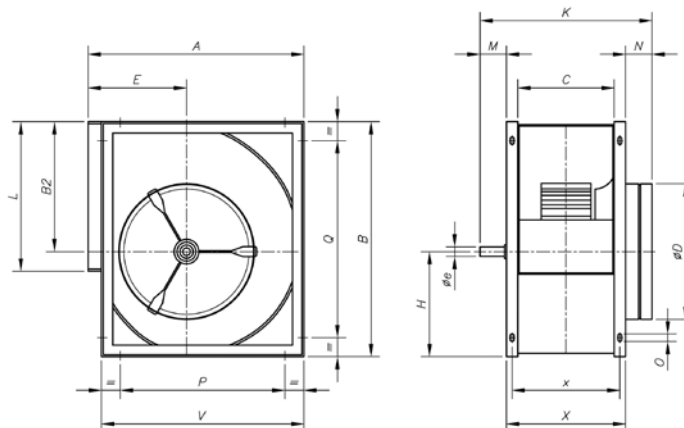

Model	A	B	B2	C	øD	E	øe	H	K	L	M	N	O	P	Q	V	X	x
TSA-12/6	498	532	290	210	325	230	25	242	435	345	75	90	9x17	324	324	468	270	242
TSA-15/7	583	632	348	269	400	265	25	284	494	404	75	90	9x17	406	406	553	329	301
TSA-18/9	694	756	415	301	475	323	25	341	526	482	75	90	9x17	520	608	664	361	333

Dimensions in mm

TSA

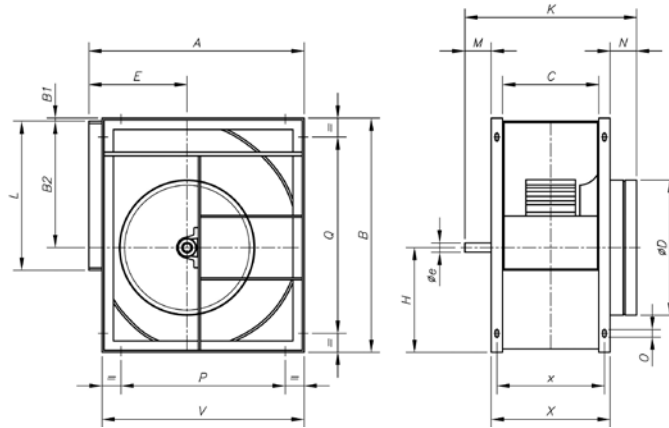

Model	A	B	B1	B2	C	øD	E	øe	H	K	L	M	N	O	P	Q	V	X	x
TSA-20/10	843	963	35	523	330	575	375	35	440	620	603	100	110	9x17	646	811	798	410	370
TSA-22/11	913	1046	35	569	358	615	400	35	477	648	693	100	110	9x17	716	894	868	438	398
TSA-25/13	998	1161	35	642	412	695	423	35	519	701	793	100	110	9x17	801	1009	953	492	452
TSA-30/14	1206	1400	35	776	474	835	515	40	624	764	933	100	110	9x17	1009	1248	1161	554	514

TSAT

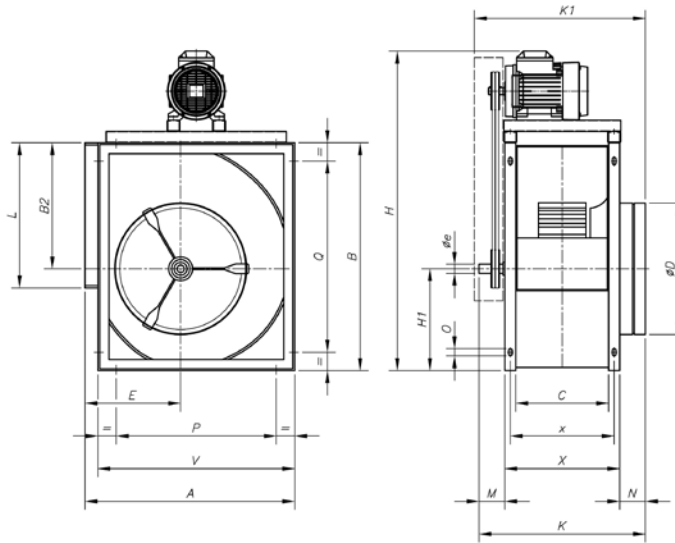

Model	A	B	B2	C	øD	E	øe	H	H1	K	K1	L	M	N	O	P	Q	V	X	x
TSAT-12/6-0'75	498	532	290	210	325	230	25	805	242	435	475	345	75	90	9x17	324	324	468	270	242
TSAT-12/6-1	498	532	290	210	325	230	25	805	242	435	475	345	75	90	9x17	324	324	468	270	242
TSAT-12/6-1'5	498	532	290	210	325	230	25	825	242	435	475	345	75	90	9x17	324	324	468	270	242
TSAT-12/6-2	498	532	290	210	325	230	25	825	242	435	475	345	75	90	9x17	324	324	468	270	242
TSAT-12/6-3	498	532	290	210	325	230	25	845	242	435	475	345	75	90	9x17	324	324	468	270	242
TSAT-15/7-1	583	632	348	269	400	265	25	905	284	494	535	404	75	90	9x17	406	406	553	329	301
TSAT-15/7-1'5	583	632	348	269	400	265	25	925	284	494	535	404	75	90	9x17	406	406	553	329	301
TSAT-15/7-2	583	632	348	269	400	265	25	925	284	494	535	404	75	90	9x17	406	406	553	329	301
TSAT-15/7-3	583	632	348	269	400	265	25	945	284	494	535	404	75	90	9x17	406	406	553	329	301
TSAT-15/7-4	583	632	348	269	400	265	25	945	284	494	535	404	75	90	9x17	406	406	553	329	301
TSAT-18/9-1'5	694	756	415	301	475	323	25	1050	341	526	566	482	75	90	9x17	520	608	664	361	333
TSAT-18/9-2	694	756	415	301	475	323	25	1050	341	526	566	482	75	90	9x17	520	608	664	361	333
TSAT-18/9-3	694	756	415	301	475	323	25	1070	341	526	566	482	75	90	9x17	520	608	664	361	333
TSAT-18/9-4	694	756	415	301	475	323	25	1070	341	526	566	482	75	90	9x17	520	608	664	361	333
TSAT-18/9-5'5	694	756	415	301	475	323	25	1095	341	526	566	482	75	90	9x17	520	608	664	361	333

Dimensions in mm

TSAT

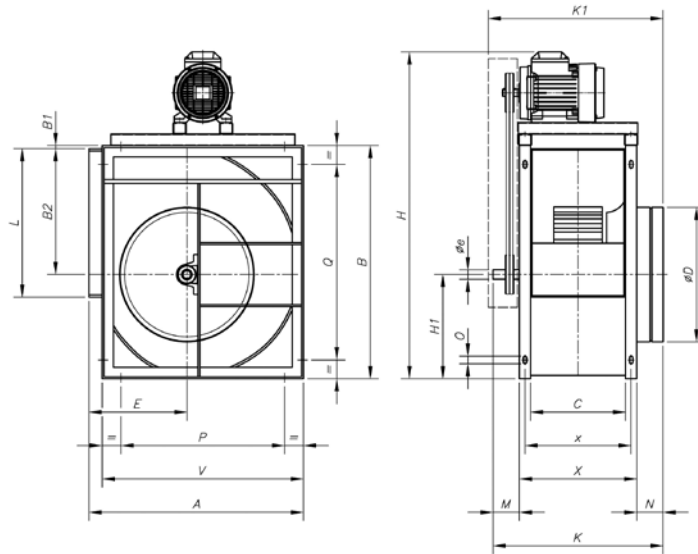

Model	A	B	B1	B2	C	øD	E	øe	H	H1	K	K1	L	M	N	O	P	Q	V	X	x
TSAT-20/10-2	843	963	35	523	330	575	375	35	1255	440	620	670	603	100	110	9x17	646	811	798	410	370
TSAT-20/10-3	843	963	35	523	330	575	375	35	1275	440	620	670	603	100	110	9x17	646	811	798	410	370
TSAT-20/10-4	843	963	35	523	330	575	375	35	1275	440	620	670	603	100	110	9x17	646	811	798	410	370
TSAT-20/10-5'5	843	963	35	523	330	575	375	35	1300	440	620	670	603	100	110	9x17	646	811	798	410	370
TSAT-20/10-7'5	843	963	35	523	330	575	375	35	1340	440	620	670	603	100	110	9x17	646	811	798	410	370
TSAT-22/11-3	913	1046	35	569	358	615	400	35	1355	477	648	700	693	100	110	9x17	716	894	868	438	398
TSAT-22/11-4	913	1046	35	569	358	615	400	35	1355	477	648	700	693	100	110	9x17	716	894	868	438	398
TSAT-22/11-5'5	913	1046	35	569	358	615	400	35	1280	477	648	700	693	100	110	9x17	716	894	868	438	398
TSAT-22/11-7'5	913	1046	35	569	358	615	400	35	1420	477	648	700	693	100	110	9x17	716	894	868	438	398
TSAT-22/11-10	913	1046	35	569	358	615	400	35	1420	477	648	700	693	100	110	9x17	716	894	868	438	398
TSAT-22/11-12'5	913	1046	35	569	358	615	400	35	1420	477	648	700	693	100	110	9x17	716	894	868	438	398
TSAT-22/11-15	913	1046	35	569	358	615	400	35	1480	477	648	700	693	100	110	9x17	716	894	868	438	398
TSAT-22/11-20	913	1046	35	569	358	615	400	35	1480	477	648	700	693	100	110	9x17	716	894	868	438	398
TSAT-22/11-25	913	1046	35	569	358	615	400	35	1565	477	648	700	693	100	110	9x17	716	894	868	438	398
TSAT-25/13-4	998	1161	35	642	412	695	423	35	1470	519	701	750	793	100	110	9x17	801	1009	953	492	452
TSAT-25/13-5'5	998	1161	35	642	412	695	423	35	1495	519	701	750	793	100	110	9x17	801	1009	953	492	452
TSAT-25/13-7'5	998	1161	35	642	412	695	423	35	1540	519	701	750	793	100	110	9x17	801	1009	953	492	452
TSAT-25/13-10	998	1161	35	642	412	695	423	35	1540	519	701	750	793	100	110	9x17	801	1009	953	492	452
TSAT-25/13-12'5	998	1161	35	642	412	695	423	35	1540	519	701	750	793	100	110	9x17	801	1009	953	492	452
TSAT-25/13-15	998	1161	35	642	412	695	423	35	1565	519	701	750	793	100	110	9x17	801	1009	953	492	452
TSAT-25/13-20	998	1161	35	642	412	695	423	35	1565	519	701	750	793	100	110	9x17	801	1009	953	492	452
TSAT-25/13-25	998	1161	35	642	412	695	423	35	1680	519	701	750	793	100	110	9x17	801	1009	953	492	452
TSAT-30/14-5'5	1206	1400	35	776	474	835	515	40	1735	624	764	815	933	100	110	9x17	1009	1248	1161	554	514
TSAT-30/14-7'5	1206	1400	35	776	474	835	515	40	1775	624	764	815	933	100	110	9x17	1009	1248	1161	554	514
TSAT-30/14-10	1206	1400	35	776	474	835	515	40	1775	624	764	815	933	100	110	9x17	1009	1248	1161	554	514
TSAT-30/14-12'5	1206	1400	35	776	474	835	515	40	1775	624	764	815	933	100	110	9x17	1009	1248	1161	554	514
TSAT-30/14-15	1206	1400	35	776	474	835	515	40	1835	624	764	815	933	100	110	9x17	1009	1248	1161	554	514
TSAT-30/14-20	1206	1400	35	776	474	835	515	40	1835	624	764	815	933	100	110	9x17	1009	1248	1161	554	514
TSAT-30/14-25	1206	1400	35	776	474	835	515	40	1925	624	764	815	933	100	110	9x17	1009	1248	1161	554	514

Dimensions in mm

CJTSA

Standard supply horizontal outlet (H) RD-90

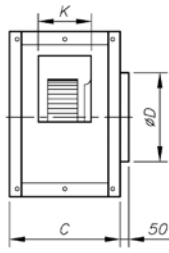
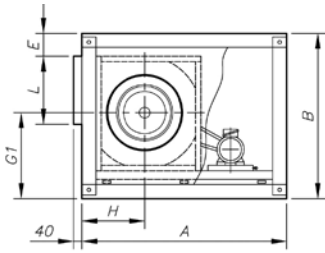

On request vertical outlet (V) RD-0

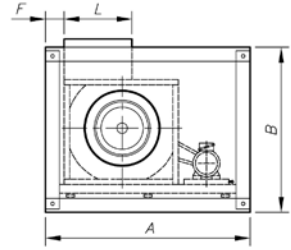
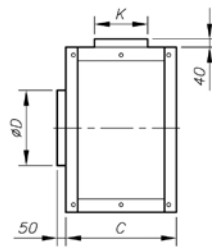

On request horizontal outlet (H) LG-90

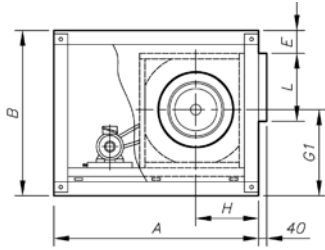
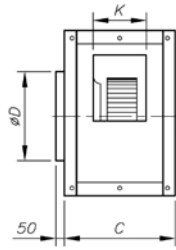

On request vertical outlet (V) LG-0

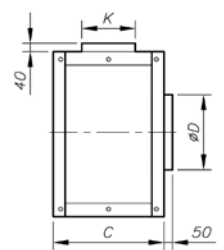
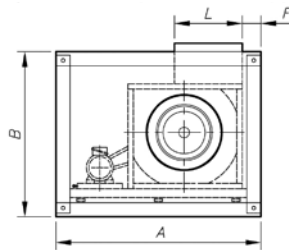

Model	A	B	C	ØD	E	with bedplate		G1	with bedplate		L	with bedplate	
						F	E		H	L		K	
CJTSA-12/6-H	850	650	540	330	74	-	-	288	-	288	346	-	210
CJTSA-12/6-V	850	650	540	330	-	-	30	318	-	328	346	-	210
CJTSA-15/7-H	1000	755	600	400	74	-	-	328	-	328	411	-	270
CJTSA-15/7-V	1000	755	600	400	-	-	30	378	-	383	411	-	270
CJTSA-18/9-H	1200	875	620	480	74	-	-	383	-	388	491	-	305
CJTSA-18/9-V	1200	875	620	480	-	-	30	433	-	448	491	-	305
CJTSA-20/10-H	1485	1175	730	565	175	120	-	475	530	440	613	605	343
CJTSA-20/10-V	1485	1175	730	565	-	-	75	535	-	585	613	-	343
CJTSA-22/11-H	1570	1250	760	615	165	110	-	510	565	470	708	700	373
CJTSA-22/11-V	1570	1250	760	615	-	-	75	570	-	640	708	-	373
CJTSA-25/13-H	1610	1375	820	685	175	120	-	550	605	495	803	795	423
CJTSA-25/13-V	1610	1375	820	685	-	-	75	625	-	705	803	-	423
CJTSA-30/14-H	1845	1600	855	820	160	95	-	655	710	580	943	935	488
CJTSA-30/14-V	1845	1600	855	820	-	-	75	760	-	825	943	-	488

Characteristic curves

Q = Airflow in m³/h, m³/s and cfm.

Pe = Static pressure in mm.w.c., Pa and in wg.

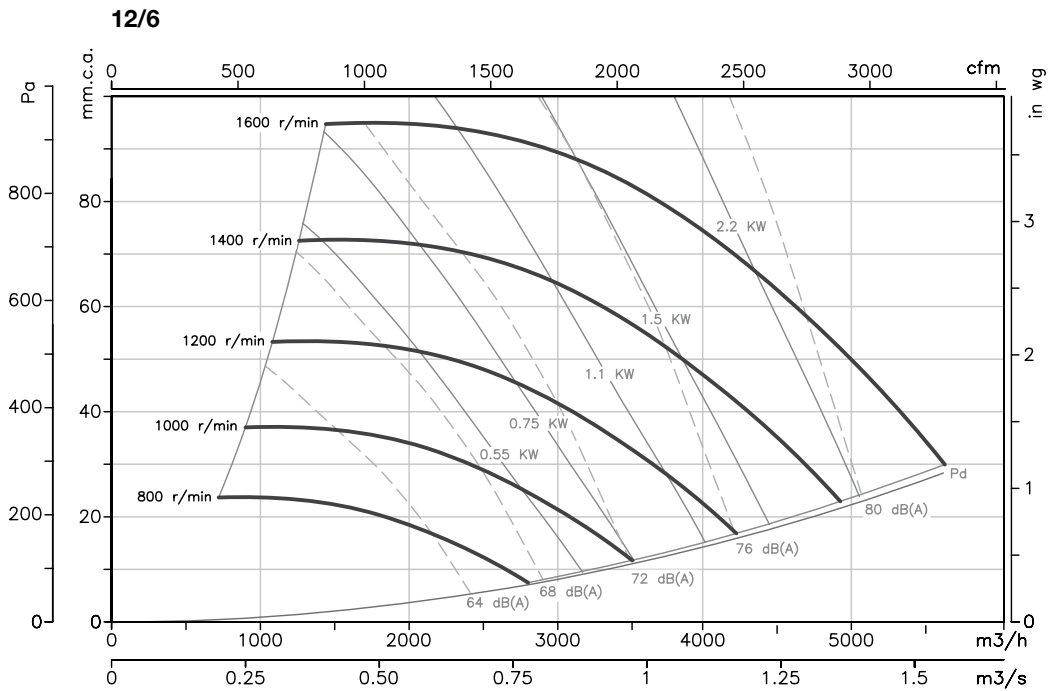

Characteristic curves

Q = Airflow in m³/h, m³/s and cfm.

Pe = Static pressure in mm.w.c., Pa and in wg.

15/7

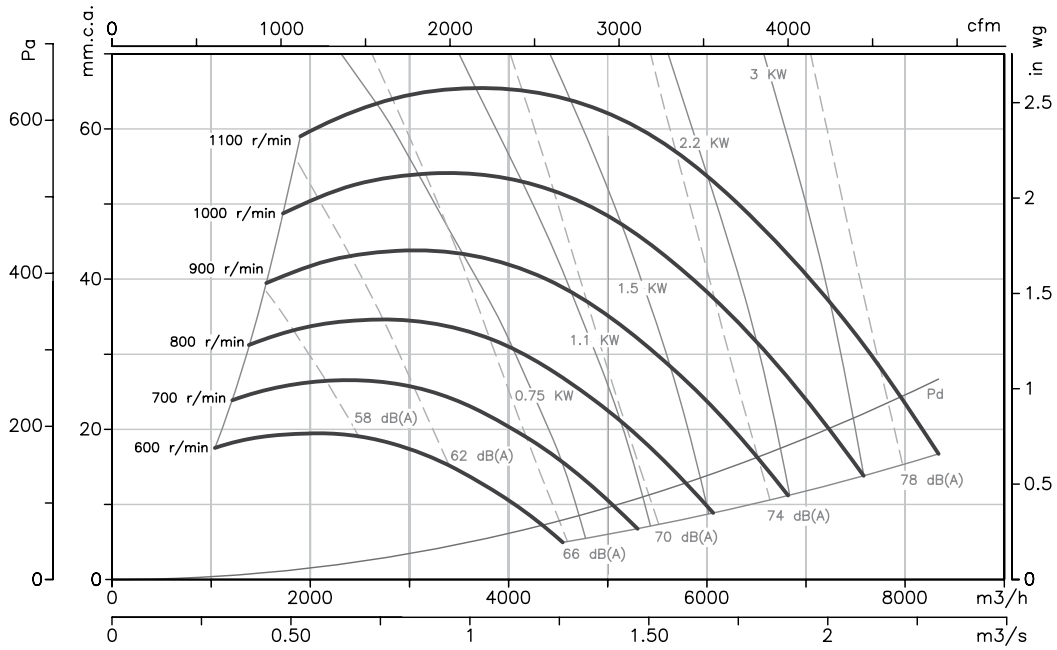

18/9

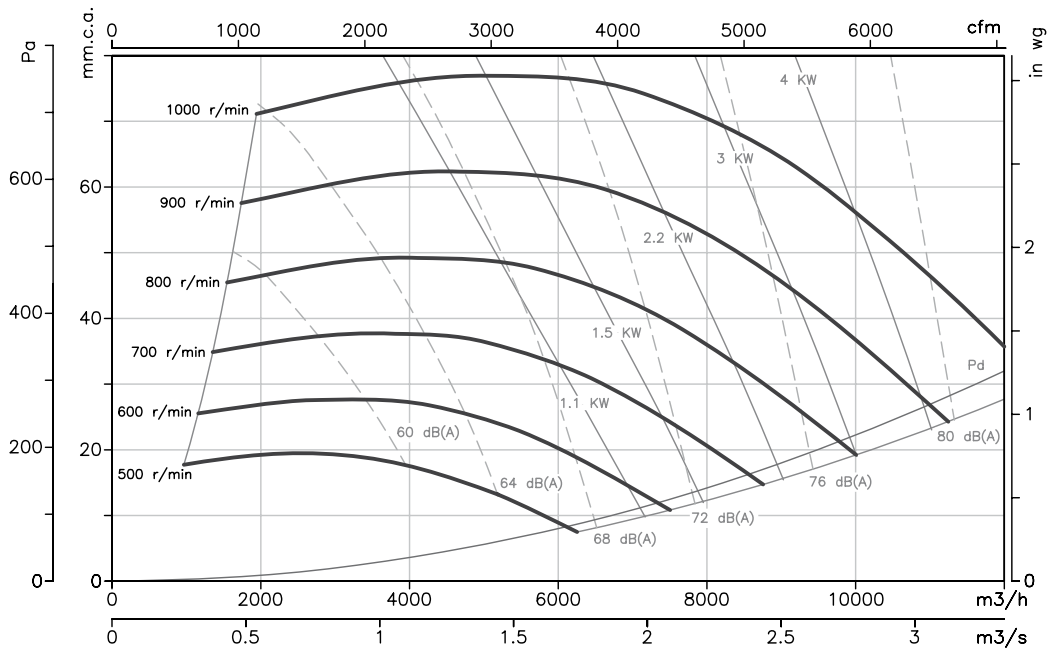

Characteristic curves

Q = Airflow in m³/h, m³/s and cfm.

Pe= Static pressure in mm.w.c., Pa and in wg.

20/10

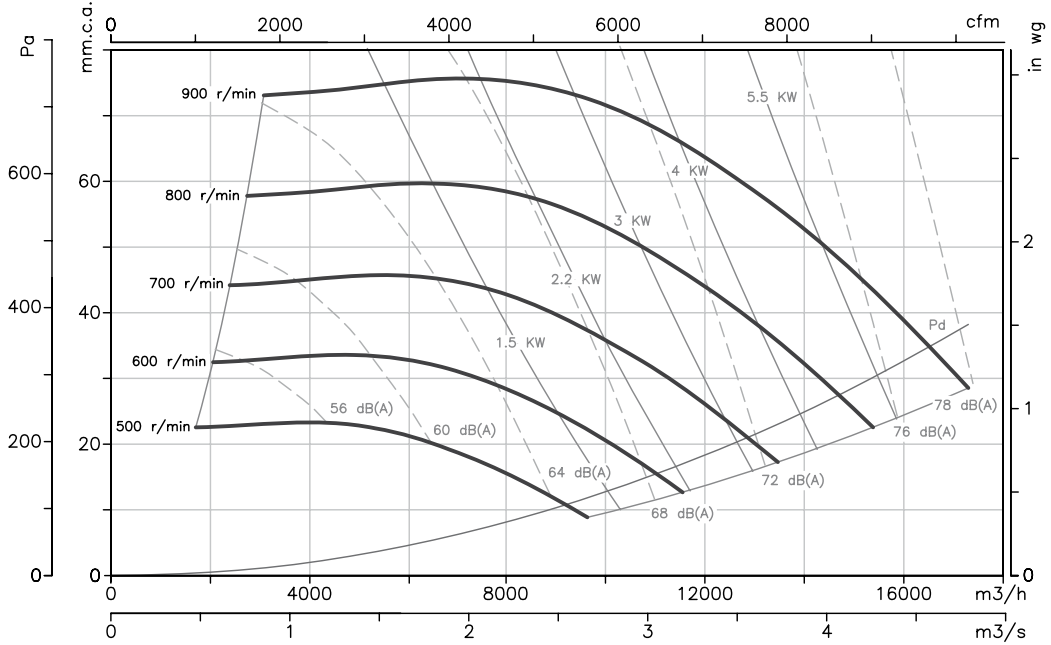

22/11

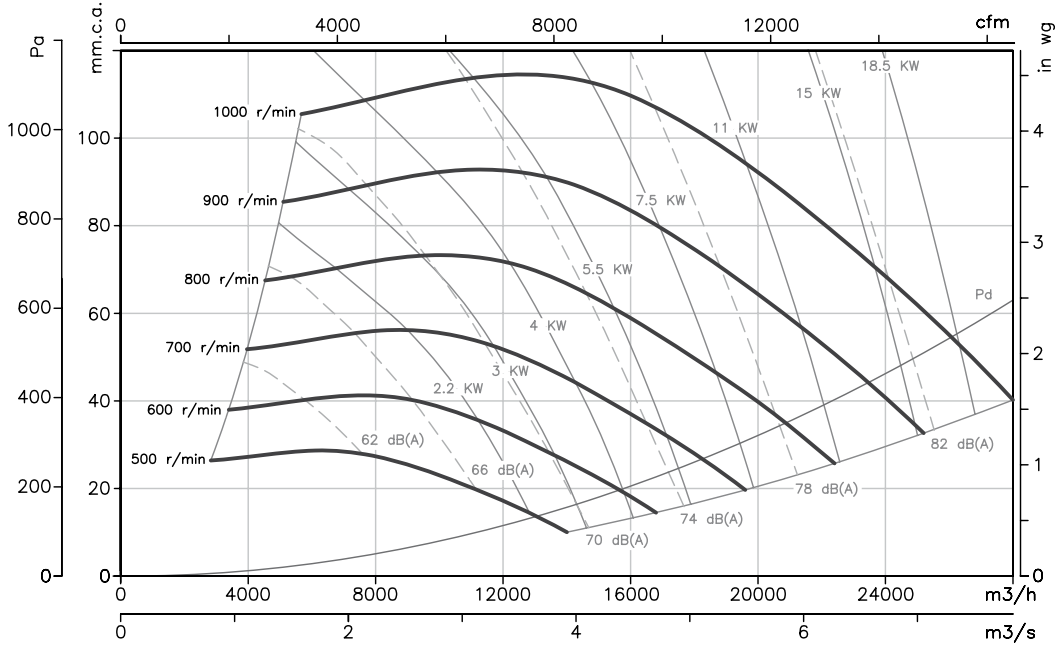

Characteristic curves

Q = Airflow in m³/h, m³/s and cfm.

Pe= Static pressure in mm.w.c., Pa and in wg.

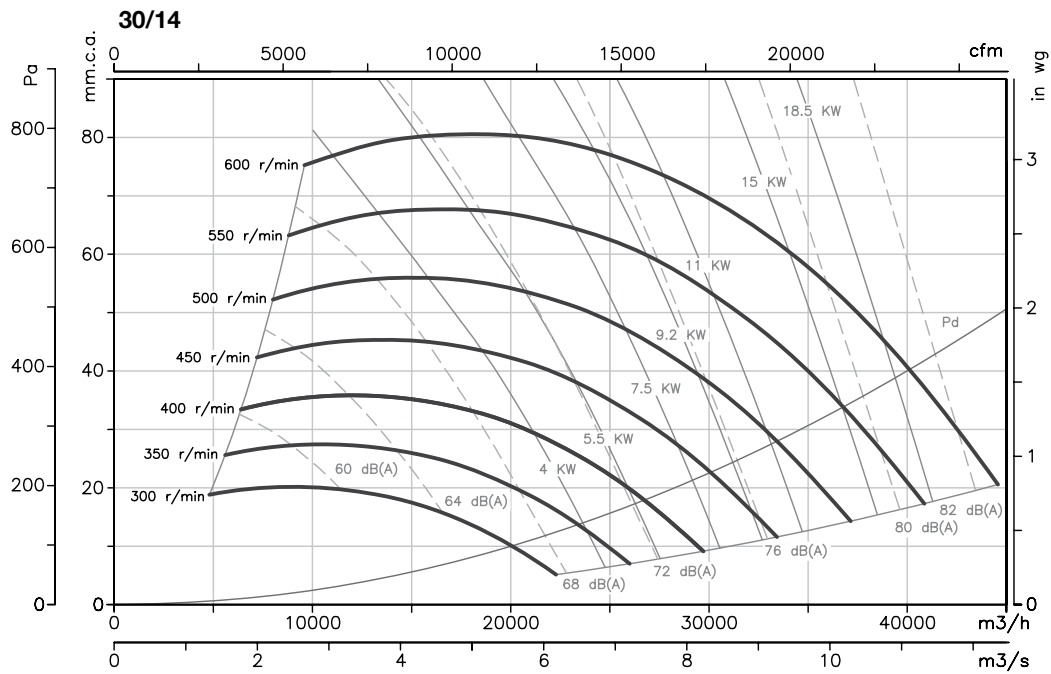
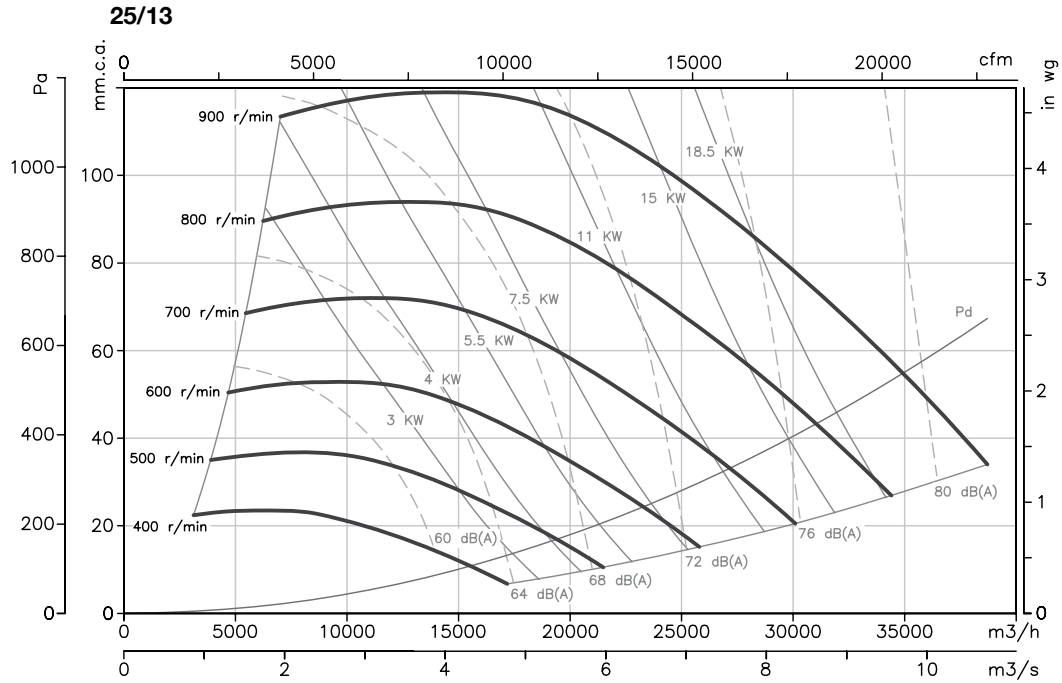

Accessories



INT

C2V

RM

AR

RFT

AET

VIS

TEJ

CDXR CDXRT CJDXR

CDXR: Double-inlet, belt-driven centrifugal fans with axis outlet on both sides and impeller with backward-facing blades

CDXRT: Double-inlet, belt-driven centrifugal fans with electric motor, pulley, belt kit and standardised protectors and impeller with backward-facing blades.

CJDXR: Soundproof ventilation units with backward-facing blades, fitted with CDXR series fans on rubber dampers



CDXR



CDXRT



CJDXR

Fan:

- Galvanized sheet steel casing
- Impeller with backward-facing blades made from galvanised sheet steel
- Galvanised sheet steel structure with thermal insulation and soundproofing (CJDXR)
- Stuffing-box for cable input (CJDXR)

Motor:

- Motors with IE-2 efficiency, except for motors with lower powers than 0.75 kW, monophase motors or two-speed motors
- Class F motors with ball bearings, IP55 protection
- Three-phase 230/400V, 50Hz (up to 5.5CV) and 400/690V, 50Hz (power over 5.5CV)
- Max. air temperature to transport: -20°C. +60°C.

Finish:

- Anticorrosive galvanized sheet steel.

On request:

- Different outlet positions
- Special windings for different voltages
- With 2 speed motors

Order code

CDXR — 450



CDXR: Centrifugal double-inlet fans with axis outlet and impeller with backward-facing blades.



Impeller size in mm

CDXRT — 450 — 3



CDXRT: Double-inlet, belt-driven centrifugal fans with electric motor impeller, with backward-facing blades.



Impeller size in mm



Motor power (c.v.)

CJDXR: Ventilation units with impeller with backward-facing blades.

Technical characteristics

Model	Max. Speed (r/min)	Installed Power (kW)	Maximum Airflow (m³/h)	Air temperature (°C)		Approx. weight (Kg)
				min.	max.	
CDXR-200	4900	2,2	3950	-20	85	10,0
CDXR-250	4100	3,0	5500	-20	85	18,0
CDXR-315	3200	4,0	10550	-20	85	32,6
CDXR-355	2800	5,5	13950	-20	85	42,7
CDXR-400	2400	5,5	16000	-20	85	50,6
CDXR-450	2200	7,5	20700	-20	85	67,5
CDXR-500	2000	11,0	27200	-20	85	84,2
CDXR-560	1800	15,0	34710	-20	85	142,0
CDXR-630	1700	22,0	47000	-20	85	168,0
CDXR-710	1400	22	53750	-20	85	223

Technical characteristics

Model			Max. Speed (r/min)	Installed Power (kW)	Maximum Airflow (m³/h)	Air temperature (°C)		Approx. weight (Kg)	Assembly type
						min.	max.		
CDXRT	CJDXR	355-0,5	1085	0.33	5600	-20	85	47.7	A
CDXRT	CJDXR	355-0,75	1230	0.55	6400	-20	85	49.3	A
CDXRT	CJDXR	355-1	1360	0.75	7100	-20	85	50.9	A
CDXRT	CJDXR	355-1,5	1540	1.10	8060	-20	85	52.6	A
CDXRT	CJDXR	355-2	1700	1.50	8890	-20	85	55.6	A
CDXRT	CJDXR	355-3	1930	2.20	10100	-20	85	58.4	A
CDXRT	CJDXR	355-4	2180	3.00	11395	-20	85	65.7	A
CDXRT	CJDXR	355-5,5	2400	4.00	12545	-20	85	72.7	B
CDXRT	CJDXR	355-7,5	2670	5.50	13955	-20	85	85.7	B
CDXRT	CJDXR	400-0,75	1010	0.55	7340	-20	85	57.2	A
CDXRT	CJDXR	400-1	1130	0.75	8140	-20	85	58.8	A
CDXRT	CJDXR	400-1,5	1290	1.10	9350	-20	85	60.5	A
CDXRT	CJDXR	400-2	1420	1.50	10260	-20	85	63.5	A
CDXRT	CJDXR	400-3	1620	2.20	11650	-20	85	66.3	A
CDXRT	CJDXR	400-4	1820	3.00	13110	-20	85	73.6	A
CDXRT	CJDXR	400-5,5	2000	4.00	14430	-20	85	80.6	B
CDXRT	CJDXR	400-7,5	2230	5.50	16040	-20	85	93.6	B
CDXRT	CJDXR	450-1	940	0.75	9500	-20	85	75.7	A
CDXRT	CJDXR	450-1,5	1075	1.10	10750	-20	85	77.4	A
CDXRT	CJDXR	450-2	1190	1.50	11960	-20	85	80.4	A
CDXRT	CJDXR	450-3	1340	2.20	13600	-20	85	83.2	A
CDXRT	CJDXR	450-4	1510	3.00	15100	-20	85	90.5	A
CDXRT	CJDXR	450-5,5	1670	4.00	16835	-20	85	97.5	B
CDXRT	CJDXR	450-7,5	1850	5.50	18500	-20	85	110.5	B
CDXRT	CJDXR	450-10	2060	7.50	20760	-20	85	120.5	B
CDXRT	CJDXR	500-1,5	880	1.10	12460	-20	85	94.1	A
CDXRT	CJDXR	500-2	970	1.50	13815	-20	85	97.1	A
CDXRT	CJDXR	500-3	1100	2.20	15700	-20	85	99.9	A
CDXRT	CJDXR	500-4	1240	3.00	17650	-20	85	107.2	A
CDXRT	CJDXR	500-5,5	1370	4.00	19430	-20	85	114.2	B
CDXRT	CJDXR	500-7,5	1510	5.50	21600	-20	85	127.2	B
CDXRT	CJDXR	500-10	1675	7.50	23950	-20	85	137.2	B
CDXRT	CJDXR	500-15	1910	11.00	27220	-20	85	156.2	B
CDXRT	CJDXR	560-2	810	1.50	15620	-20	85	154.9	A
CDXRT	CJDXR	560-3	925	2.20	17830	-20	85	157.7	A
CDXRT	CJDXR	560-4	1050	3.00	20380	-20	85	165.0	A
CDXRT	CJDXR	560-5,5	1150	4.00	22170	-20	85	172.0	B
CDXRT	CJDXR	560-7,5	1290	5.50	24940	-20	85	185.0	B
CDXRT	CJDXR	560-10	1420	7.50	27658	-20	85	195.0	B
CDXRT	CJDXR	560-15	1610	11.00	31050	-20	85	214.0	B
CDXRT	CJDXR	560-20	1800	15.00	34710	-20	85	227.0	B
CDXRT	CJDXR	630-3	740	2.20	21210	-20	85	183.7	A
CDXRT	CJDXR	630-4	830	3.00	23860	-20	85	191.0	A
CDXRT	CJDXR	630-5,5	920	4.00	26260	-20	85	198.0	B
CDXRT	CJDXR	630-7,5	1020	5.50	29200	-20	85	211.0	B
CDXRT	CJDXR	630-10	1135	7.50	32385	-20	85	221.0	B
CDXRT	CJDXR	630-15	1285	11.00	36800	-20	85	240.0	B
CDXRT	CJDXR	630-20	1450	15.00	41415	-20	85	253.0	B
CDXRT	CJDXR	630-25	1550	18.50	44410	-20	85	270.0	B
CDXRT	CJDXR	630-30	1640	22.00	47050	-20	85	313.0	B
CDXRT	CJDXR	710-3	580	2.20	23200	-20	85	238.7	A
CDXRT	CJDXR	710-4	655	3.00	26200	-20	85	246.0	A
CDXRT	CJDXR	710-5,5	730	4.00	29200	-20	85	253.0	B
CDXRT	CJDXR	710-7,5	805	5.50	32200	-20	85	266.0	B
CDXRT	CJDXR	710-10	890	7.50	35600	-20	85	276.0	B
CDXRT	CJDXR	710-15	1015	11.00	40600	-20	85	295.0	B
CDXRT	CJDXR	710-20	1140	15.00	45600	-20	85	308.0	B
CDXRT	CJDXR	710-25	1225	18.50	49000	-20	85	325.0	B
CDXRT	CJDXR	710-30	1300	22.00	52000	-20	85	368.0	B

Dimensions in mm

CDXR 200 - 250

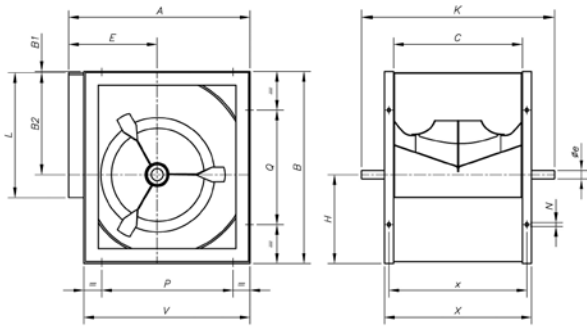

CDXR 315...710

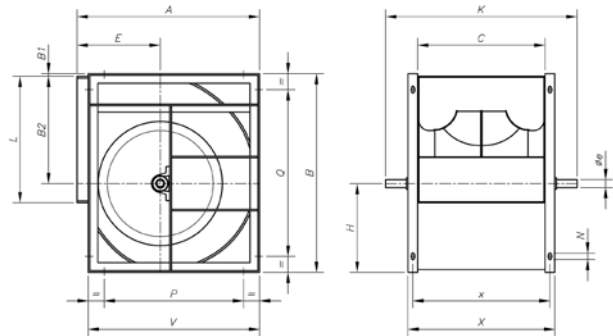

	A	B	B1	B2	C	E	øe	H	K	L	N	P	Q	V	X	x
CDXR-200	343	370	4	215	256	164	20	151	420	256	11x16	224	224	306	306	281
CDXR-250	419	461	4	270	322	195	20	187	490	322	11x16	224	224	384	372	347
CDXR-315	518	578	3	340	404	236	25	235	640	404	13x18	280	280	480	464	434
CDXR-355	578	655	6	383	453	261	30	266	700	453	13x18	355	355	548	533	493
CDXR-400	651	736	4,5	431,5	507	290	30	300	760	507	13x18	355	355	613	587	547
CDXR-450	728	827	5	486	569	322	35	336	845	569	13x18	530	530	681	649	609
CDXR-500	800	918	5	538	638	352	35	375	915	638	13x18	530	530	750	718	678
CDXR-560	893	1030	8	602	715	390	40	420	1000	715	13x18	530	530	845	815	765
CDXR-630	999	1157	7	678,5	801	434	45	471,5	1090	801	13x18	530	530	946	901	851
CDXR-710	1121	1303	7	765	898	485	50	531	1255	898	17x22	630	630	1058	998	948

CDXRT Installation A

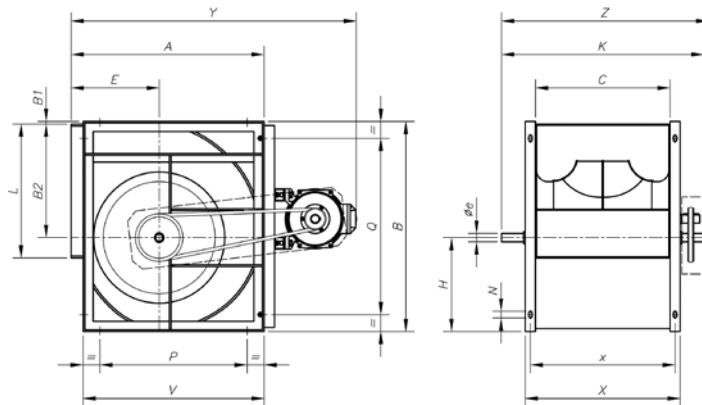

Model	A	B	B1	B2	C	E	øe	H	K	L	N	P	Q	V	X	x	Y	Z
CDXRT-355-0'5	578	655	6	383	453	261	30	266	700	453	13x18	355	355	548	533	493	830	780
CDXRT-355-0'75	578	655	6	383	453	261	30	266	700	453	13x18	355	355	548	533	493	850	780
CDXRT-355-1	578	655	6	383	453	261	30	266	700	453	13x18	355	355	548	533	493	850	780
CDXRT-355-1'5	578	655	6	383	453	261	30	266	700	453	13x18	355	355	548	533	493	870	780
CDXRT-355-2	578	655	6	383	453	261	30	266	700	453	13x18	355	355	548	533	493	870	780
CDXRT-355-3	578	655	6	383	453	261	30	266	700	453	13x18	355	355	548	533	493	885	780
CDXRT-355-4	578	655	6	383	453	261	30	266	700	453	13x18	355	355	548	533	493	885	780
CDXRT-400-0'75	651	736	4,5	431,5	507	290	30	300	760	507	13x18	355	355	613	587	547	925	840
CDXRT-400-1	651	736	4,5	431,5	507	290	30	300	760	507	13x18	355	355	613	587	547	925	840
CDXRT-400-1'5	651	736	4,5	431,5	507	290	30	300	760	507	13x18	355	355	613	587	547	940	840
CDXRT-400-2	651	736	4,5	431,5	507	290	30	300	760	507	13x18	355	355	613	587	547	940	840
CDXRT-400-3	651	736	4,5	431,5	507	290	30	300	760	507	13x18	355	355	613	587	547	956	840
CDXRT-400-4	651	736	4,5	431,5	507	290	30	300	760	507	13x18	355	355	613	587	547	956	840
CDXRT-450-1	728	827	5	486	569	322	35	336	845	569	13x18	530	530	681	649	609	1000	925
CDXRT-450-1'5	728	827	5	486	569	322	35	336	845	569	13x18	530	530	681	649	609	1020	925
CDXRT-450-2	728	827	5	486	569	322	35	336	845	569	13x18	530	530	681	649	609	1020	925
CDXRT-450-3	728	827	5	486	569	322	35	336	845	569	13x18	530	530	681	649	609	1035	925
CDXRT-450-4	728	827	5	486	569	322	35	336	845	569	13x18	530	530	681	649	609	1035	925
CDXRT-500-1'5	800	918	5	538	638	352	35	375	915	638	13x18	530	530	750	718	678	1090	995
CDXRT-500-2	800	918	5	538	638	352	35	375	915	638	13x18	530	530	750	718	678	1090	995
CDXRT-500-3	800	918	5	538	638	352	35	375	915	638	13x18	530	530	750	718	678	1105	995
CDXRT-500-4	800	918	5	538	638	352	35	375	915	638	13x18	530	530	750	718	678	1105	995
CDXRT-560-2	893	1030	8	602	715	390	40	420	1000	715	13x18	530	530	845	815	765	1185	1080
CDXRT-560-3	893	1030	8	602	715	390	40	420	1000	715	13x18	530	530	845	815	765	1205	1080
CDXRT-560-4	893	1030	8	602	715	390	40	420	1000	715	13x18	530	530	845	815	765	1205	1080
CDXRT-630-3	999	1157	7	678,5	801	434	45	471,5	1090	801	13x18	530	530	946	901	851	1310	1170
CDXRT-630-4	999	1157	7	678,5	801	434	45	471,5	1090	801	13x18	530	530	946	901	851	1310	1170
CDXRT-710-3	1121	1303	7	765	898	485	50	531	1255	898	17x22	630	630	1058	998	948	1435	1335
CDXRT-710-4	1121	1303	7	765	898	485	50	531	1255	898	17x22	630	630	1058	998	948	1435	1335

Dimensions in mm

CDXRT Installation B

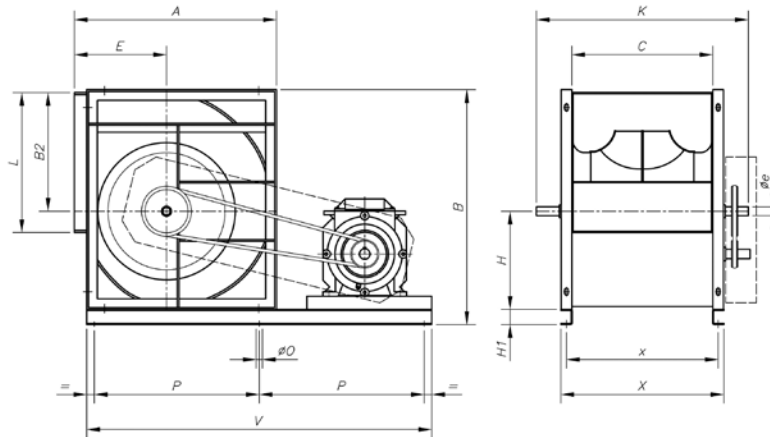

Model	A	B	B2	C	E	øe	H	H1	K	L	øO	P	V	x	X
CDXRT-355-5'5	578	715	383	453	261	30	266	60	700	453	12	495	1070	493	533
CDXRT-355-7'5	578	715	383	453	261	30	266	60	700	453	12	495	1070	493	533
CDXRT-400-5'5	651	796	431.5	507	290	30	300	60	760	507	12	540	1160	547	587
CDXRT-400-7'5	651	796	431.5	507	290	30	300	60	760	507	12	540	1160	547	587
CDXRT-450-5'5	728	887	486	569	322	35	336	60	845	569	12	635	1350	609	649
CDXRT-450-7'5	728	887	486	569	322	35	336	60	845	569	12	635	1350	609	649
CDXRT-450-10	728	887	486	569	322	35	336	60	845	569	12	635	1350	609	649
CDXRT-500-5'5	800	978	538	638	352	35	375	60	915	638	12	635	1350	678	718
CDXRT-500-7'5	800	978	538	638	352	35	375	60	915	638	12	635	1350	678	718
CDXRT-500-10	800	978	538	638	352	35	375	60	915	638	12	635	1350	678	718
CDXRT-500-15	800	978	538	638	352	35	375	60	915	638	12	635	1350	678	718
CDXRT-560-5'5	893	1090	602	715	390	40	420	60	1000	715	12	680	1440	765	815
CDXRT-560-7'5	893	1090	602	715	390	40	420	60	1000	715	12	680	1440	765	815
CDXRT-560-10	893	1090	602	715	390	40	420	60	1000	715	12	680	1440	765	815
CDXRT-560-15	893	1090	602	715	390	40	420	60	1000	715	12	680	1440	765	815
CDXRT-560-20	893	1090	602	715	390	40	420	60	1000	715	12	680	1440	765	815
CDXRT-630-5'5	999	1217	678.5	801	434	45	471.5	60	1090	801	12	745	1570	851	901
CDXRT-630-7'5	999	1217	678.5	801	434	45	471.5	60	1090	801	12	745	1570	851	901
CDXRT-630-10	999	1217	678.5	801	434	45	471.5	60	1090	801	12	745	1570	851	901
CDXRT-630-15	999	1217	678.5	801	434	45	471.5	60	1090	801	12	745	1570	851	901
CDXRT-630-20	999	1217	678.5	801	434	45	471.5	60	1090	801	12	745	1570	851	901
CDXRT-630-25	999	1217	678.5	801	434	45	471.5	60	1090	801	12	745	1570	851	901
CDXRT-630-30	999	1217	678.5	801	434	45	471.5	60	1090	801	12	745	1570	851	901
CDXRT-710-5'5	1121	1363	765	898	485	50	531	60	1255	898	12	860	1800	948	998
CDXRT-710-7'5	1121	1363	765	898	485	50	531	60	1255	898	12	860	1800	948	998
CDXRT-710-10	1121	1363	765	898	485	50	531	60	1255	898	12	860	1800	948	998
CDXRT-710-15	1121	1363	765	898	485	50	531	60	1255	898	12	860	1800	948	998
CDXRT-710-20	1121	1363	765	898	485	50	531	60	1255	898	12	860	1800	948	998
CDXRT-710-25	1121	1363	765	898	485	50	531	60	1255	898	12	860	1800	948	998
CDXRT-710-30	1121	1363	765	898	485	50	531	60	1255	898	12	860	1800	948	998

CJDXR

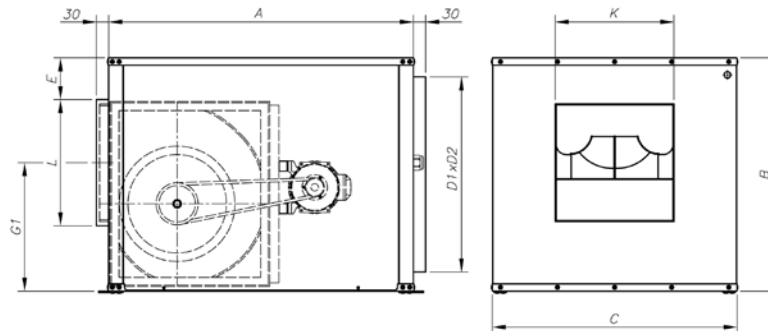

Installation A

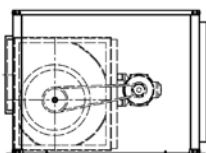

Installation B

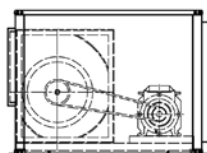

Model	A	B	C	D1xD2	E	G1	LxK
CJDXR-355	1000	755	800	661x706	36,5	484	468.5x468.5
CJDXR-400	1200	875	1000	781x906	58	555,5	522.5x522.5
CJDXR-450	1300	1025	1050	929x956	98	634,5	584.5x584.5
CJDXR-500	1400	1175	1100	1079x1004	157,5	691	635.5x635.5
CJDXR-560	1480	1250	1250	1154x1154	118	766,5	730.5x730.5
CJDXR-630	1660	1375	1450	1279x1354	115	851,5	816.5x816.5
CJDXR-710	1800	1600	1650	1504x1554	194	949	913.5x913.5

Characteristic curves

Q = Airflow in m³/h, m³/s and cfm.

Pe = Static pressure in mm.w.c., Pa and in wg.

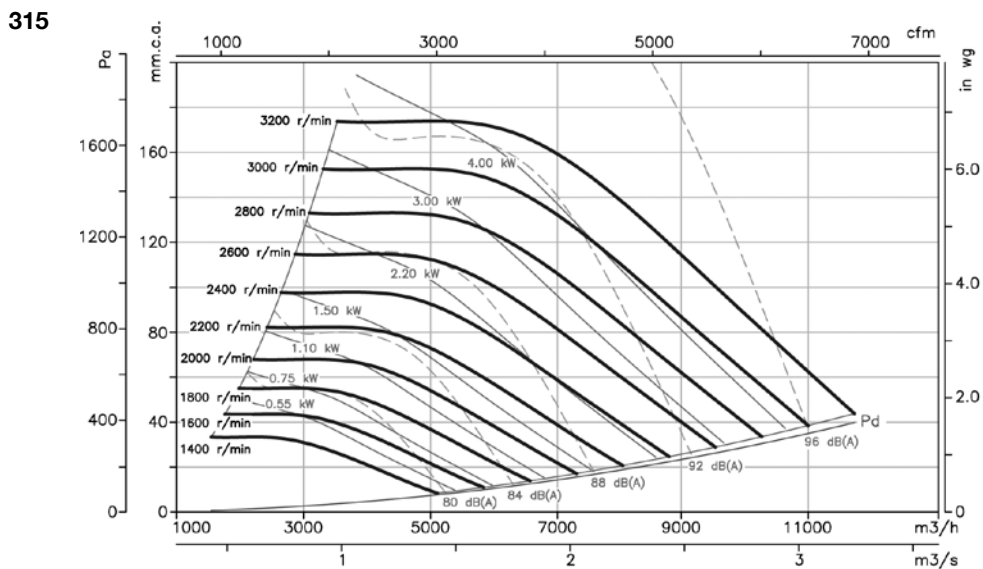
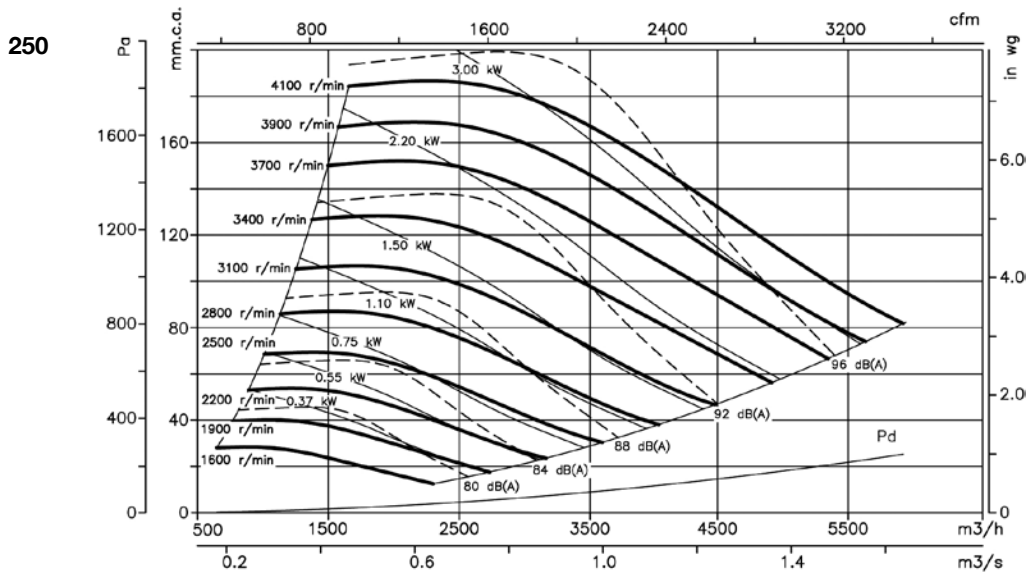
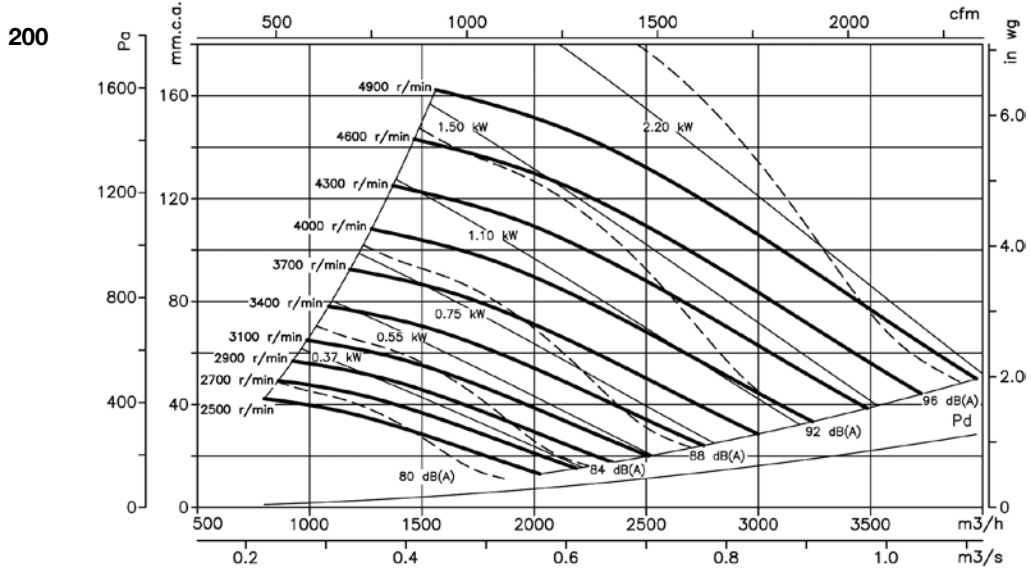

Characteristic curves

Q = Airflow in m³/h, m³/s and cfm.

Pe= Static pressure in mm.w.c., Pa and in wg.

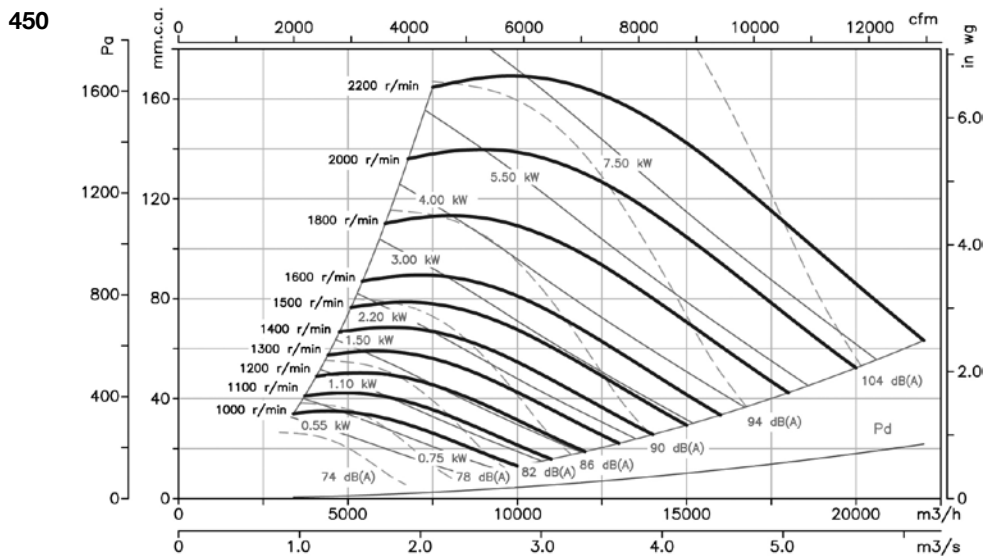
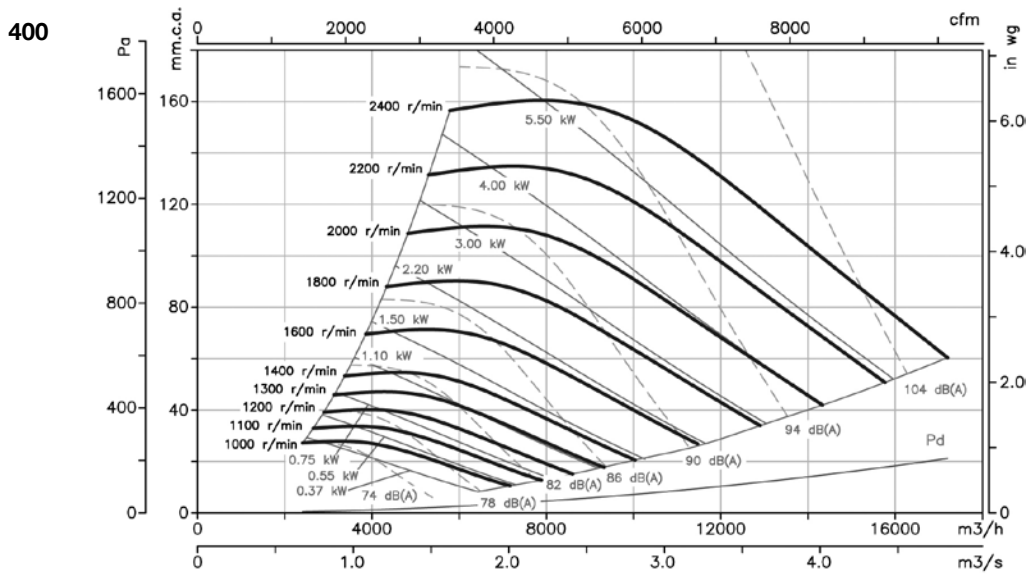
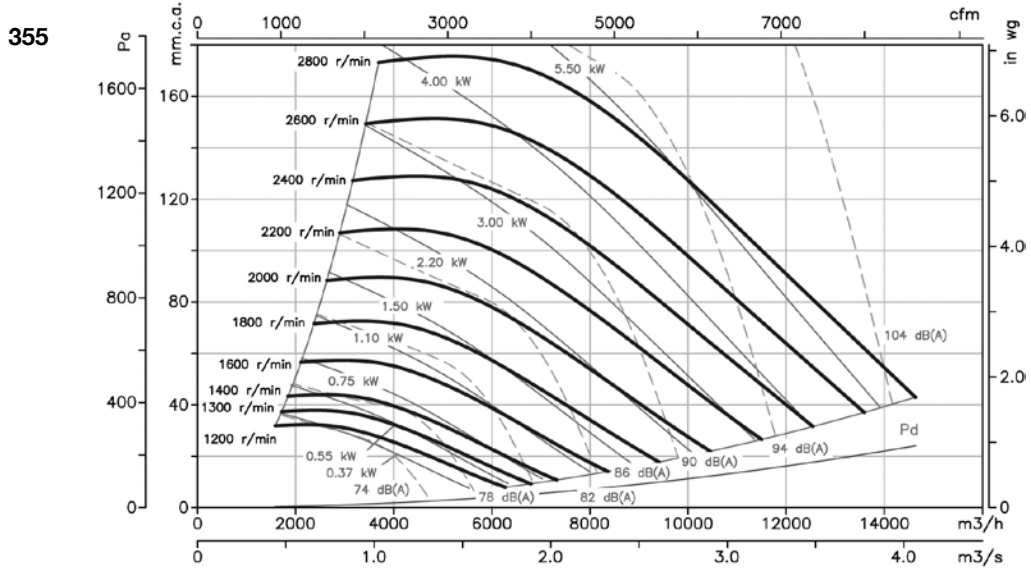

Characteristic curves

Q = Airflow in m³/h, m³/s and cfm.

Pe= Static pressure in mm.w.c., Pa and in wg.

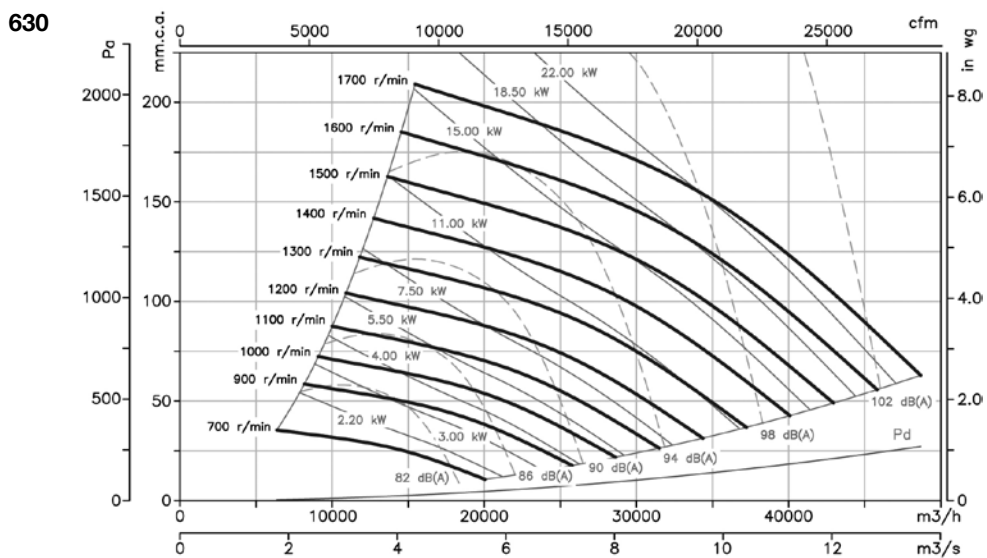
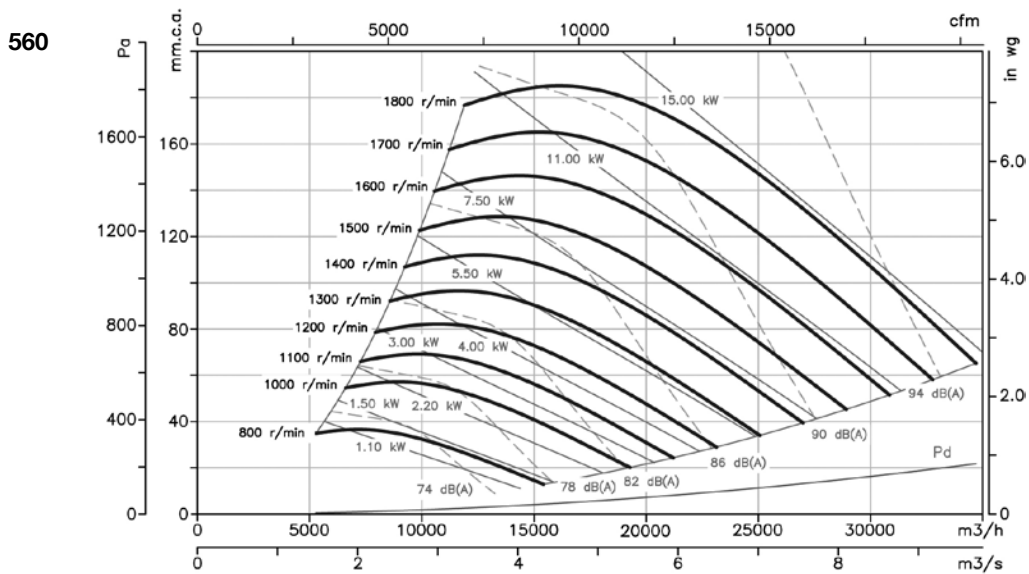
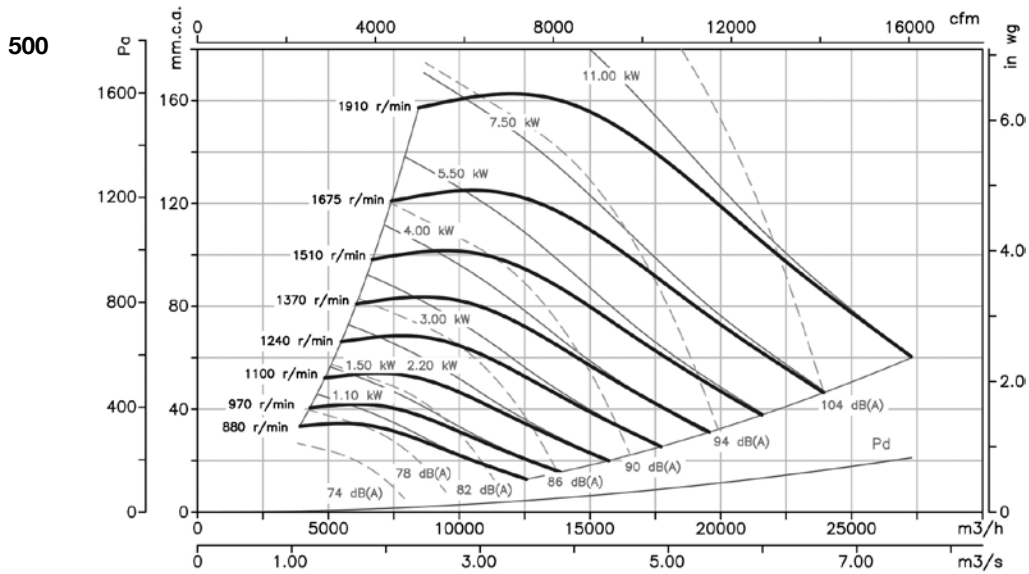

Characteristic curves

Q = Airflow in m³/h, m³/s and cfm.

Pe= Static pressure in mm.w.c., Pa and in wg.

710

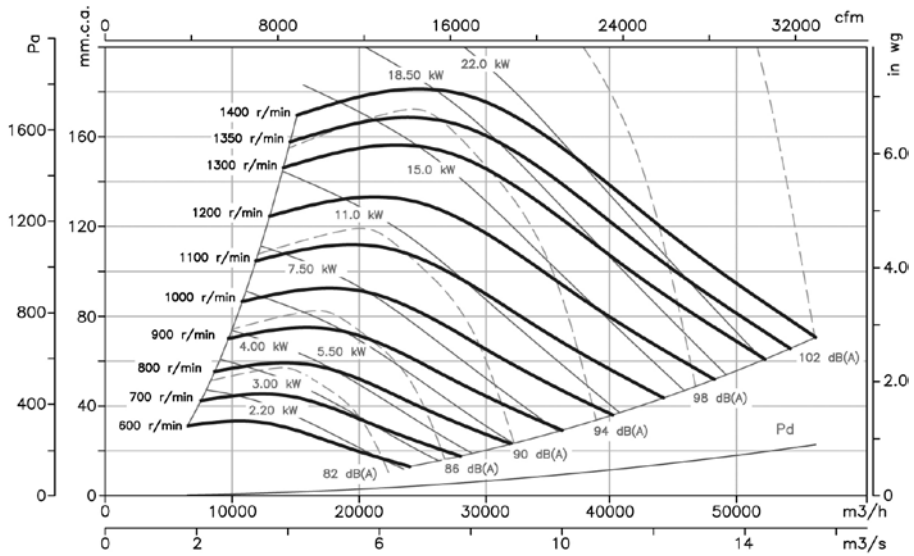

Accessories



CSXR CSXRT CJSXR

CSXR: Single-inlet, belt-driven centrifugal fans with axis outlet and impeller with backward-facing blades

CSXRT: Single-inlet, belt-driven centrifugal fans with electric motor, pulley, belt kit and standardised protectors and impeller with backward-facing blades.

CJSXR: Soundproof ventilation units with backward-facing blades, fitted with CSXR series fans on rubber dampers



CSXR



CSXRT



CJSXR

Fan:

- Galvanized sheet steel casing
- Impeller with backward-facing blades made from galvanised sheet steel
- Galvanised sheet steel structure with thermal insulation and soundproofing (CJSXR)
- Stuffing-box for cable input (CJSXR)

Motor:

- Motors with IE-2 efficiency, except for motors with lower powers than 0.75 kW, monophase motors or two-speed motors
- Class F motors with ball bearings, IP55 protection
- Three-phase 230/400V. 50Hz (up to 5.5CV) and 400/690V. 50Hz (power over 5.5CV)
- Max. air temperature to transport: -20°C. +60°C.

Finish:

- Anticorrosive galvanized sheet steel.

On request:

- Different outlet positions
- Special windings for different voltages
- With 2 speed motors

Order code

CSXR — 400



CSXR: Centrifugal single-inlet fans with axis outlet

Impeller size

CSXRT — 500 — 4



CSXRT: Centrifugal single-inlet fans with motor

Impeller size

Power motor (c.v.)

CJSXR: Ventilation units with impeller with backward-facing blades

Technical characteristics

Model	Max. Speed (r/min)	Max. Power installed (kW)	Maximum Airflow (m³/h)	Air temperature (°C)		Approx. weight (Kg)
				min.	max.	
CSXR-315	3200	1.1	5050	-20	85	27
CSXR-355	2800	1.5	6650	-20	85	39
CSXR-400	2400	1.5	7700	-20	85	44
CSXR-450	2200	3	10100	-20	85	55
CSXR-500	2200	5.5	14000	-20	85	70
CSXR-560	2000	7.5	18300	-20	85	110
CSXR-630	1600	7.5	19800	-20	85	125
CSXR-710	1400	9.2	25920	-20	85	175
CSXR-800	1600	22	40000	-20	85	252
CSXR-900	1400	30	51000	-20	85	360
CSXR-1000	1400	37	64000	-20	85	445

Technical characteristics

Model			Speed (r/min)	Maximum admissible current (A)			Installed Power (kW)	Maximum Airflow (m³/h)	Approx. weight (Kg)	Assembly type	
				230V	400V	690V				CSXRT	CJSXR
CSXRT	CJSXR	315-0,75	2520	2.4	1.4	-	0.55	4000	32	A	B
CSXRT	CJSXR	315-1	2800	3.1	1.8	-	0.75	4500	34	A	B
CSXRT	CJSXR	315-1,5	3250	4.4	2.5	-	1.1	5050	36	A	B
CSXRT	CJSXR	355-0,75	2100	2.4	1.4	-	0.55	4750	41	A	B
CSXRT	CJSXR	355-1	2300	3.1	1.8	-	0.75	5200	44	A	B
CSXRT	CJSXR	355-1,5	2600	4.4	2.5	-	1.1	6000	46	A	B
CSXRT	CJSXR	355-2	2875	5.8	3.4	-	1.5	6650	48	A	B
CSXRT	CJSXR	400-0,75	1730	2.4	1.4	-	0.55	5600	49	A	B
CSXRT	CJSXR	400-1	1900	3.3	1.9	-	0.75	6100	52	A	B
CSXRT	CJSXR	400-1,5	2180	4.5	2.6	-	1.1	7000	54	A	B
CSXRT	CJSXR	400-2	2400	5.8	3.4	-	1.5	7700	56	A	B
CSXRT	CJSXR	450-0,75	1230	2.4	1.4	-	0.55	5800	61	A	B
CSXRT	CJSXR	450-1	1380	3.3	1.9	-	0.75	6500	64	A	B
CSXRT	CJSXR	450-1,5	1550	4.5	2.6	-	1.1	7500	66	A	B
CSXRT	CJSXR	450-2	1700	6.0	3.5	-	1.5	8050	68	A	B
CSXRT	CJSXR	450-3	1950	8.4	4.8	-	2.2	9050	72	A	B
CSXRT	CJSXR	450-4	2200	10.4	6.0	-	3	10100	76	A	B
CSXRT	CJSXR	500-1,5	1250	4.5	2.6	-	1.1	8200	88	A	B
CSXRT	CJSXR	500-2	1380	6.0	3.5	-	1.5	9000	90	A	B
CSXRT	CJSXR	500-3	1560	8.4	4.8	-	2.2	10200	93	A	B
CSXRT	CJSXR	500-4	1730	11.3	6.5	-	3	11500	98	A	B
CSXRT	CJSXR	500-5,5	1900	13.9	8.0	-	4	12500	107	A	B
CSXRT	CJSXR	500-7,5	2130	-	11.1	6.4	5.5	14000	116	A	B
CSXRT	CJSXR	560-2	1200	6.0	3.5	-	1.5	11000	100	A	B
CSXRT	CJSXR	560-3	1380	8.4	4.8	-	2.2	12200	103	A	B
CSXRT	CJSXR	560-4	1500	11.3	6.5	-	3	14000	108	A	B
CSXRT	CJSXR	560-5,5	1670	13.9	8.0	-	4	15500	117	A	B
CSXRT	CJSXR	560-7,5	1850	-	11.1	6.4	5.5	16200	122	A	B
CSXRT	CJSXR	560-10	2050	-	14.8	8.6	7.5	18300	132	A	B
CSXRT	CJSXR	630-3	1060	8.4	4.8	-	2.2	13200	119	A	B
CSXRT	CJSXR	630-4	1150	11.3	6.5	-	3	14400	123	A	B
CSXRT	CJSXR	630-5,5	1300	13.9	8.0	-	4	16000	132	A	B
CSXRT	CJSXR	630-7,5	1450	-	11.1	6.4	5.5	18000	138	A	B
CSXRT	CJSXR	630-10	1600	-	14.8	8.6	7.5	19800	147	A	B
CSXRT	CJSXR	710-4	1000	11.3	6.5	-	3	17280	186	A	B
CSXRT	CJSXR	710-5,5	1100	13.9	8.0	-	4	19080	195	A	B
CSXRT	CJSXR	710-7,5	1200	-	11.1	6.4	5.5	20880	200	A	B
CSXRT	CJSXR	710-10	1350	-	14.8	8.6	7.5	23760	210	A	B
CSXRT	CJSXR	710-12,5	1480	-	17.5	10.1	9.2	25920	219	A	B
CSXRT		800-4	800	11.3	6.5	-	3	20800	226	B	
CSXRT		800-5,5	880	13.9	8.0	-	4	22680	234	B	
CSXRT		800-7,5	970	-	11.1	6.4	5.5	25100	240	B	
CSXRT		800-10	1070	-	14.8	8.6	7.5	27720	250	B	
CSXRT		800-12,5	1150	-	17.5	10.1	9.2	30000	259	B	
CSXRT		800-15	1230	-	22.0	12.8	11	32040	284	B	
CSXRT		800-20	1350	-	29.0	16.8	15	34000	305	B	
CSXRT		800-25	1450	-	36.5	21.2	18.5	37800	325	B	
CSXRT		800-30	1540	-	42.0	24.4	22	40000	344	B	
CSXRT		900-4	650	11.3	6.5	-	3	23760	281	B	
CSXRT		900-5,5	720	13.9	8.0	-	4	26000	289	B	
CSXRT		900-7,5	790	-	11.1	6.4	5.5	29500	295	B	
CSXRT		900-10	860	-	14.8	8.6	7.5	32100	305	B	
CSXRT		900-12,5	940	-	17.5	10.1	9.2	34200	314	B	
CSXRT		900-15	1020	-	22.0	12.8	11	37900	339	B	
CSXRT		900-20	1120	-	29.0	16.8	15	42000	360	B	
CSXRT		900-25	1190	-	36.5	21.2	18.5	43500	380	B	
CSXRT		900-30	1250	-	42.0	24.4	22	45500	399	B	
CSXRT		900-40	1400	-	59.0	34.2	30	51000	453	B	
CSXRT		1000-5,5	600	13.9	8.0	-	4	30500	342	B	
CSXRT		1000-7,5	660	-	11.1	6.4	5.5	33000	348	B	
CSXRT		1000-10	730	-	14.8	8.6	7.5	37000	358	B	
CSXRT		1000-12,5	790	-	17.5	10.1	9.2	40000	366	B	
CSXRT		1000-15	840	-	22.0	12.8	11	42500	392	B	
CSXRT		1000-20	940	-	29.0	16.8	15	46000	413	B	
CSXRT		1000-25	1000	-	36.5	21.2	18.5	50000	432	B	
CSXRT		1000-30	1060	-	42.0	24.4	22	52500	452	B	
CSXRT		1000-40	1160	-	59.0	34.2	30	59000	506	B	
CSXRT		1000-50	1260	-	68.0	39.4	37	64000	549	B	

Dimensions in mm

CSXR

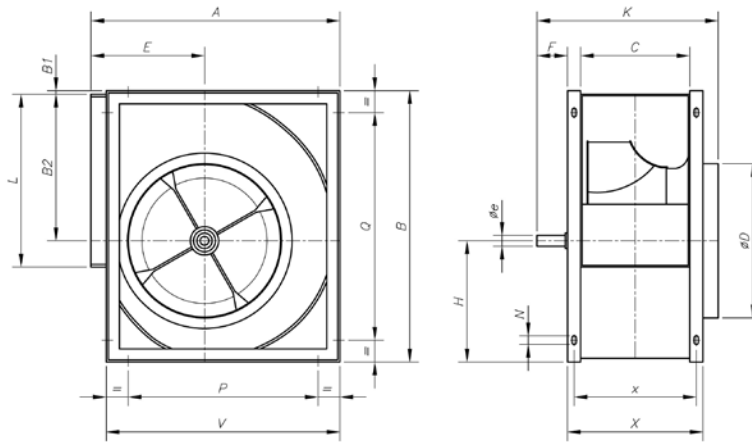

Model	A	B	B1	B2	C	øD	øe	E	F	H	K	L	N	P	Q	V	X	x
CSXR-315	518	578	3	340	223	322	25	236	83	235	395	404	13x18	280	280	480	283	253
CSXR-355	578	655	6	383	247	362	30	261	78	266	425	453	13x18	355	355	548	327	287
CSXR-400	651	736	4.5	431.5	274	404	30	290	78	300	452	507	13x18	355	355	613	354	314
CSXR-450	726	827	5	486	308	448	35	322	92	336	500	569	13x18	530	530	681	388	348
CSXR-500	800	918	5	538	344	510	35	352	92	375	535	638	13x18	530	530	750	424	394
CSXR-560	893	1030	8	602	383	570	40	390	87	420	600	715	13x18	530	530	845	483	433
CSXR-630	999	1157	7	678.5	432	635	45	434	87	471.5	650	801	13x18	530	530	946	532	482
CSXR-710	1121	1303	7	765	478	722	50	485	115	531	725	898	17x22	630	630	1058	578	528

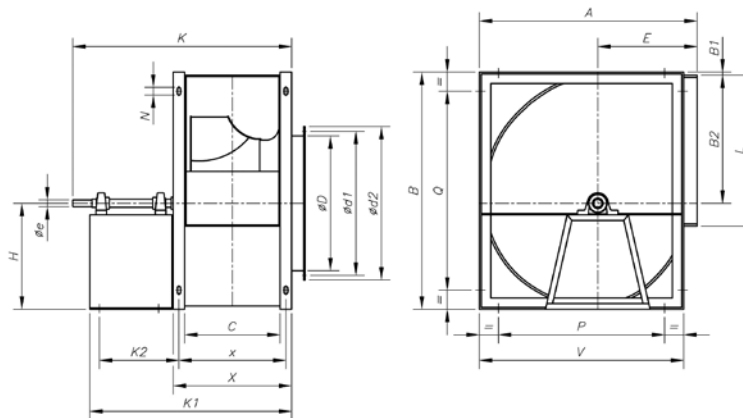

Model	A	B	B1	B2	C	øD	øD1	øD2	øe	E	H	K	K1	K2	L	N	P	Q	V	X	x
CSXR-800	1250	1468	7	862	533	808	844	875	45	535	599	1170	1060	440	1007	17x22	710	710	1181	633	583
CSXR-900	1408	1648	7	971	595	896	945	980	55	604	670	1313	1191	510	1130	17x22	800	800	1319	715	655
CSXR-1000	1541	1810	9	1066	663	996	1044	1080	55	657	735	1381	1259	510	1267	17x22	900	900	1462	783	713

Dimensions in mm

CSXRT
Installation A

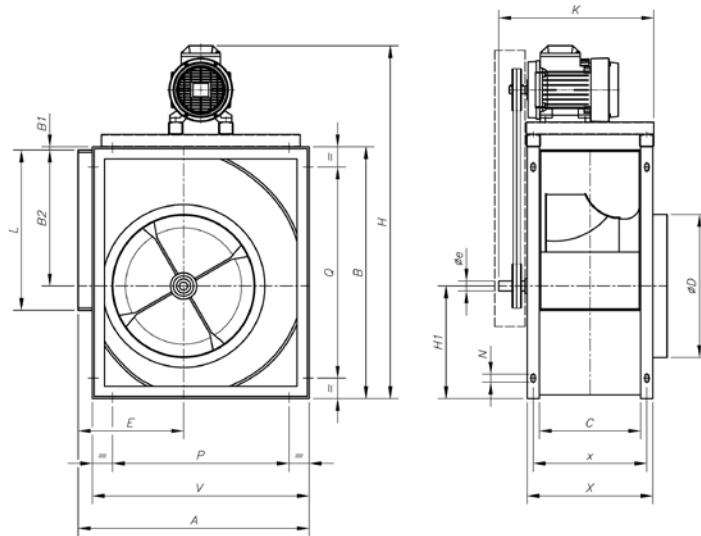

Model	A	B	B1	B2	C	øD	øe	E	H	H1	K	L	N	P	Q	V	X	x
CSXRT-315-0'75	518	578	3	340	223	322	25	236	835	235	395	404	13x18	280	280	480	283	253
CSXRT-315-1	518	578	3	340	223	322	25	236	855	235	395	404	13x19	280	280	480	283	253
CSXRT-315-1'5	518	578	3	340	223	322	25	236	855	235	395	404	13x20	280	280	480	283	253
CSXRT-315-2	518	578	3	340	223	322	25	236	875	235	395	404	13x21	280	280	480	283	253
CSXRT-315-3	518	578	3	340	223	322	25	236	875	235	395	404	13x22	280	280	480	283	253
CSXRT-355-0'75	578	655	6	383	247	362	30	261	910	266	425	453	13x18	355	355	548	327	287
CSXRT-355-1	578	655	6	383	247	362	30	261	930	266	425	453	13x19	355	355	548	327	287
CSXRT-355-1'5	578	655	6	383	247	362	30	261	930	266	425	453	13x20	355	355	548	327	287
CSXRT-355-2	578	655	6	383	247	362	30	261	945	266	425	453	13x21	355	355	548	327	287
CSXRT-355-3	578	655	6	383	247	362	30	261	945	266	425	453	13x22	355	355	548	327	287
CSXRT-355-4	578	655	6	383	247	362	30	261	963	266	425	453	13x23	355	355	548	327	287
CSXRT-400-0'75	651	736	4.5	431.5	274	404	30	290	1012	300	452	507	13x18	355	355	613	354	314
CSXRT-400-1	651	736	4.5	431.5	274	404	30	290	1012	300	452	507	13x19	355	355	613	354	314
CSXRT-400-1'5	651	736	4.5	431.5	274	404	30	290	1012	300	452	507	13x20	355	355	613	354	314
CSXRT-400-2	651	736	4.5	431.5	274	404	30	290	1033	300	452	507	13x21	355	355	613	354	314
CSXRT-400-3	651	736	4.5	431.5	274	404	30	290	1033	300	452	507	13x22	355	355	613	354	314
CSXRT-400-4	651	736	4.5	431.5	274	404	30	290	1045	300	452	507	13x23	355	355	613	354	314
CSXRT-400-5'5	651	736	4.5	431.5	274	404	30	290	1072	300	452	507	13x24	355	355	613	354	314
CSXRT-450-0'75	726	827	5	486	308	448	35	322	1100	336	500	569	13x18	530	530	681	388	348
CSXRT-450-1	726	827	5	486	308	448	35	322	1100	336	500	569	13x19	530	530	681	388	348
CSXRT-450-1'5	726	827	5	486	308	448	35	322	1120	336	500	569	13x20	530	530	681	388	348
CSXRT-450-2	726	827	5	486	308	448	35	322	1120	336	500	569	13x21	530	530	681	388	348
CSXRT-450-3	726	827	5	486	308	448	35	322	1138	336	500	569	13x22	530	530	681	388	348
CSXRT-450-4	726	827	5	486	308	448	35	322	1138	336	500	569	13x23	530	530	681	388	348
CSXRT-450-5'5	726	827	5	486	308	448	35	322	1162	336	500	569	13x24	530	530	681	388	348
CSXRT-450-7'5	726	827	5	486	308	448	35	322	1205	336	500	569	13x25	530	530	681	388	348
CSXRT-450-10	726	827	5	486	308	448	35	322	1205	336	500	569	13x26	530	530	681	388	348
CSXRT-450-12'5	726	827	5	486	308	448	35	322	1205	336	500	569	13x27	530	530	681	388	348
CSXRT-500-1'5	800	918	5	538	344	510	35	352	1214	375	535	638	13x18	530	530	750	424	394
CSXRT-500-2	800	918	5	538	344	510	35	352	1214	375	535	638	13x19	530	530	750	424	394
CSXRT-500-3	800	918	5	538	344	510	35	352	1228	375	535	638	13x20	530	530	750	424	394
CSXRT-500-4	800	918	5	538	344	510	35	352	1228	375	535	638	13x21	530	530	750	424	394
CSXRT-500-5'5	800	918	5	538	344	510	35	352	1255	375	535	638	13x22	530	530	750	424	394
CSXRT-500-7'5	800	918	5	538	344	510	35	352	1292	375	535	638	13x23	530	530	750	424	394
CSXRT-500-10	800	918	5	538	344	510	35	352	1292	375	535	638	13x24	530	530	750	424	394
CSXRT-500-12'5	800	918	5	538	344	510	35	352	1292	375	535	638	13x25	530	530	750	424	394
CSXRT-500-15	800	918	5	538	344	510	35	352	1350	375	535	638	13x26	530	530	750	424	394

Dimensions in mm

CSXRT-560-2	893	1030	8	602	383	570	40	390	1325	420	600	715	13x18	530	530	845	483	433
CSXRT-560-3	893	1030	8	602	383	570	40	390	1340	420	600	715	13x19	530	530	845	483	433
CSXRT-560-4	893	1030	8	602	383	570	40	390	1340	420	600	715	13x20	530	530	845	483	433
CSXRT-560-5'5	893	1030	8	602	383	570	40	390	1365	420	600	715	13x21	530	530	845	483	433
CSXRT-560-7'5	893	1030	8	602	383	570	40	390	1410	420	600	715	13x22	530	530	845	483	433
CSXRT-560-10	893	1030	8	602	383	570	40	390	1410	420	600	715	13x23	530	530	845	483	433
CSXRT-560-12'5	893	1030	8	602	383	570	40	390	1410	420	600	715	13x24	530	530	845	483	433
CSXRT-560-15	893	1030	8	602	383	570	40	390	1464	420	600	715	13x25	530	530	845	483	433
CSXRT-630-3	999	1157	7	678.5	432	635	45	434	1470	471.5	650	801	13x18	530	530	946	532	482
CSXRT-630-4	999	1157	7	678.5	432	635	45	434	1470	471.5	650	801	13x19	530	530	946	532	482
CSXRT-630-5'5	999	1157	7	678.5	432	635	45	434	1492	471.5	650	801	13x20	530	530	946	532	482
CSXRT-630-7'5	999	1157	7	678.5	432	635	45	434	1531	471.5	650	801	13x21	530	530	946	532	482
CSXRT-630-10	999	1157	7	678.5	432	635	45	434	1531	471.5	650	801	13x22	530	530	946	532	482
CSXRT-630-12'5	999	1157	7	678.5	432	635	45	434	1531	471.5	650	801	13x23	530	530	946	532	482
CSXRT-630-15	999	1157	7	678.5	432	635	45	434	1590	471.5	650	801	13x24	530	530	946	532	482
CSXRT-630-20	999	1157	7	678.5	432	635	45	434	1590	471.5	650	801	13x25	530	530	946	532	482
CSXRT-710-4	1121	1303	7	765	478	722	50	485	1612	531	725	898	17x22	630	630	1058	578	528
CSXRT-710-5'5	1121	1303	7	765	478	722	50	485	1638	531	725	898	17x23	630	630	1058	578	528
CSXRT-710-7'5	1121	1303	7	765	478	722	50	485	1675	531	725	898	17x24	630	630	1058	578	528
CSXRT-710-10	1121	1303	7	765	478	722	50	485	1675	531	725	898	17x25	630	630	1058	578	528
CSXRT-710-12'5	1121	1303	7	765	478	722	50	485	1675	531	725	898	17x26	630	630	1058	578	528
CSXRT-710-15	1121	1303	7	765	478	722	50	485	1735	531	725	898	17x27	630	630	1058	578	528
CSXRT-710-20	1121	1303	7	765	478	722	50	485	1735	531	725	898	17x28	630	630	1058	578	528
CSXRT-710-25	1121	1303	7	765	478	722	50	485	1820	531	725	898	17x29	630	630	1058	578	528

**CSXRT
Installation B**

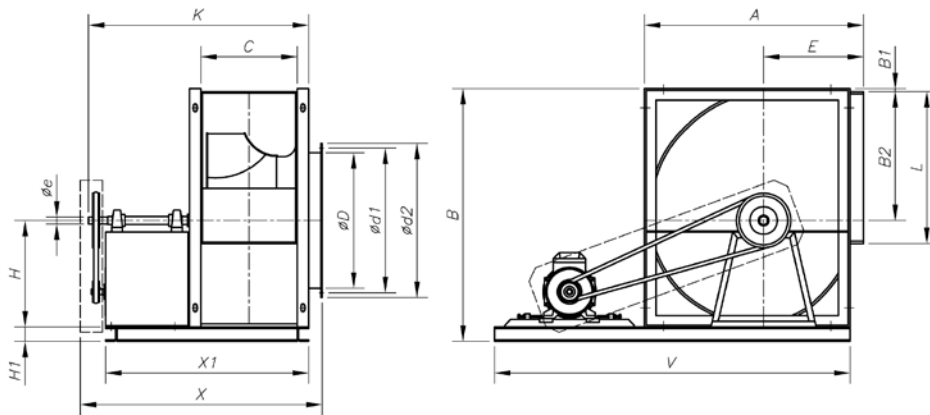

Model	A	B	B1	B2	C	øD	ød1	ød2	øe	E	H	H1	K	L	V	X	X1
CSXRT-800	1250	1548	7	862	533	808	844	875	45	535	599	80	1170	1007	1880	1245	1060
CSXRT-900	1408	1728	7	971	595	896	945	980	55	604	670	80	1313	1130	2050	1375	1291
CSXRT-1000	1541	1890	9	1066	663	996	1044	1080	55	657	735	80	1381	1267	2250	1450	1259

Dimensions in mm

CJSXR

Standard supply horizontal outlet (H) RD90

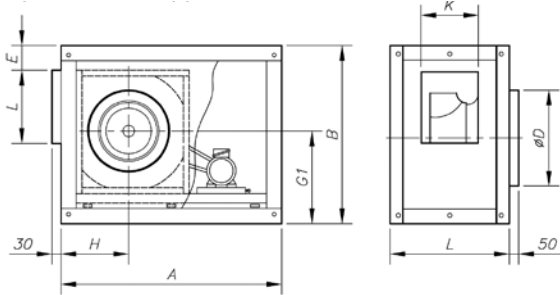

On request horizontal outlet (H) LG 90

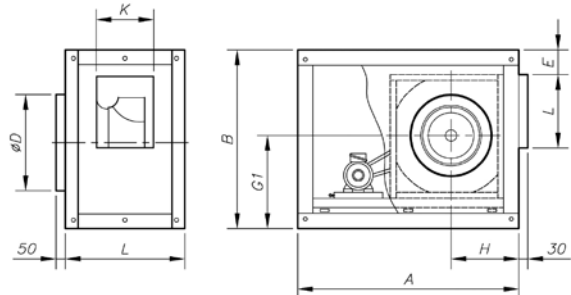

On request vertical outlet (V) LG 0

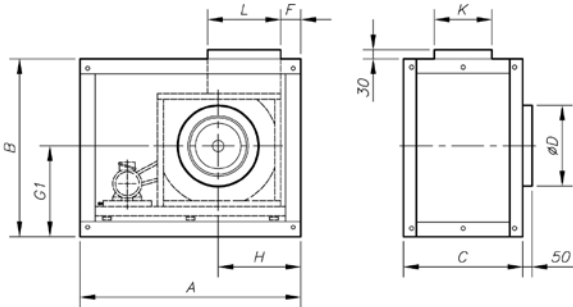

On request vertical outlet (V) RD 0

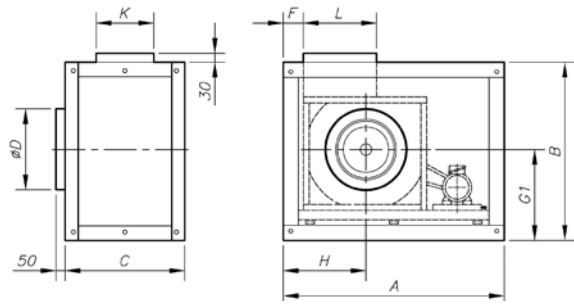

Model	A	B	C	ØD	E	F	G1	H	L	K
CJSXR-315-H	853	710	543	315	70	-	298	259.5	409	228
CJSXR-315-V	950	675	543	315	-	62	345	404.5	409	228
CJSXR-355-H	1000	785	573	365	70	-	329	292.5	458	252
CJSXR-355-V	1078	740	573	365	-	65	380	450.5	458	252
CJSXR-400-H	1200	875	583	405	77	-	363	313.5	514	280
CJSXR-400-V	1120	805	583	405	-	65	424	497.5	514	280
CJSXR-450-H	1200	955	623	450	67	-	399	338.5	575	314
CJSXR-450-V	1355	875	623	450	-	63.5	467	552.5	575	314
CJSXR-500-H	1300	1100	680	515	121	-	438	363.5	644	350
CJSXR-500-V	1430	940	680	515	-	63.5	511	604.5	644	350
CJSXR-560-H	1400	1250	736	575	162	-	483	403.5	721	390
CJSXR-560-V	1590	1070	736	575	-	66.5	566	671.5	721	390
CJSXR-630-H	1500	1380	786	640	162	-	527.5	442.5	807	438
CJSXR-630-V	1720	1170	786	640	-	65.5	630	756	807	438
CJSXR-410-H	1800	1525	860	725	161	-	596	523.5	904	484
CJSXR-710-V	1925	1285	860	725	-	65.5	701	833.5	904	484

Characteristic curves

Q = Airflow in m³/h, m³/s and cfm.

Pe = Static pressure in mm.w.c., Pa and in wg.

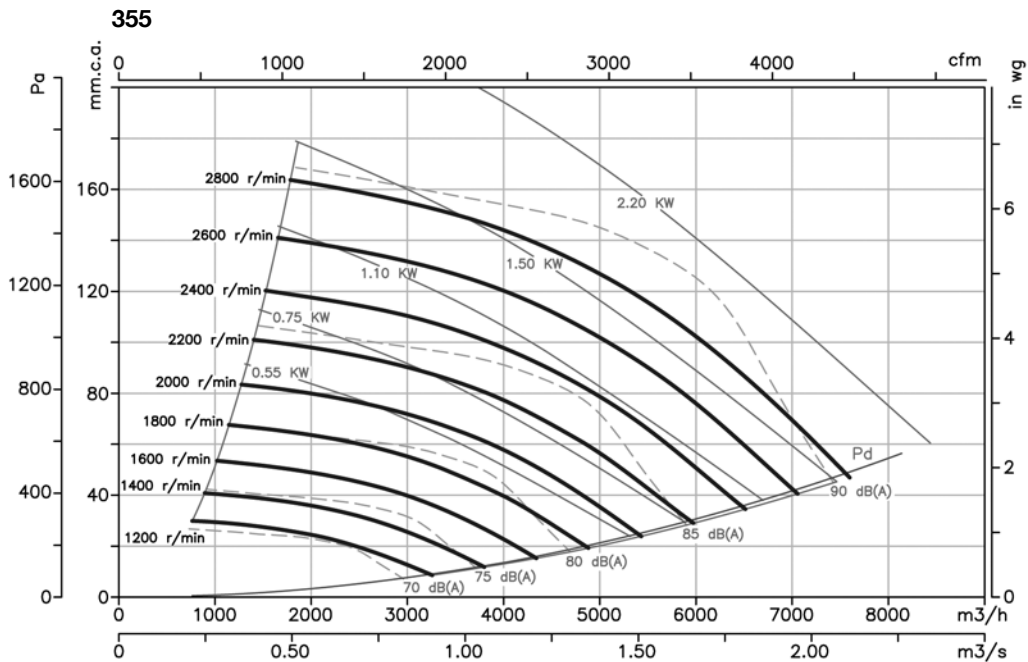
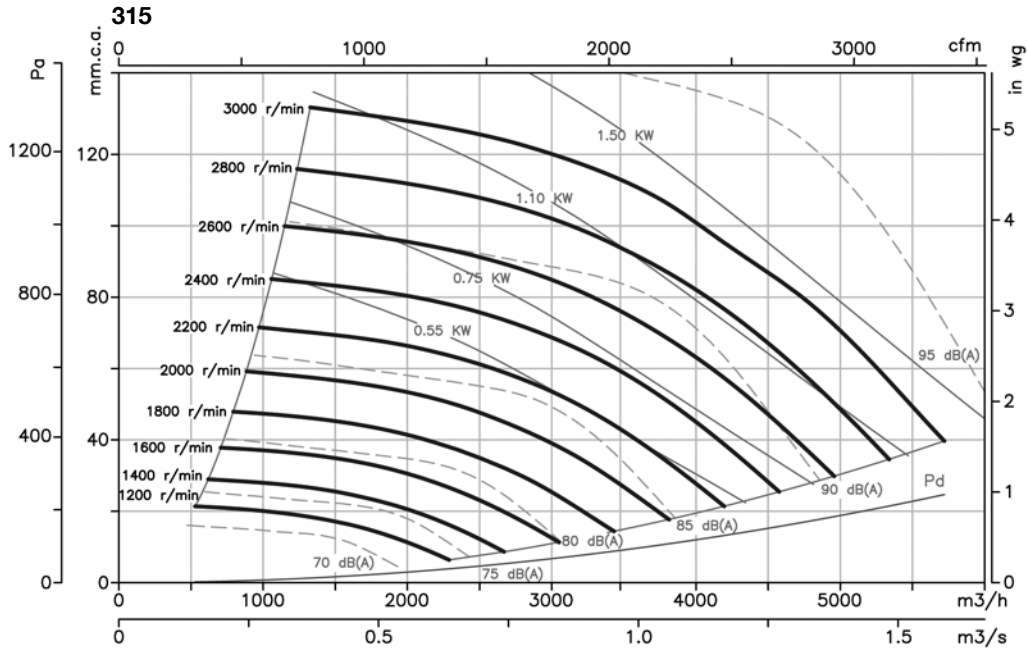

Characteristic curves

Q = Airflow in m³/h, m³/s and cfm.

Pe = Static pressure in mm.w.c., Pa and in wg.

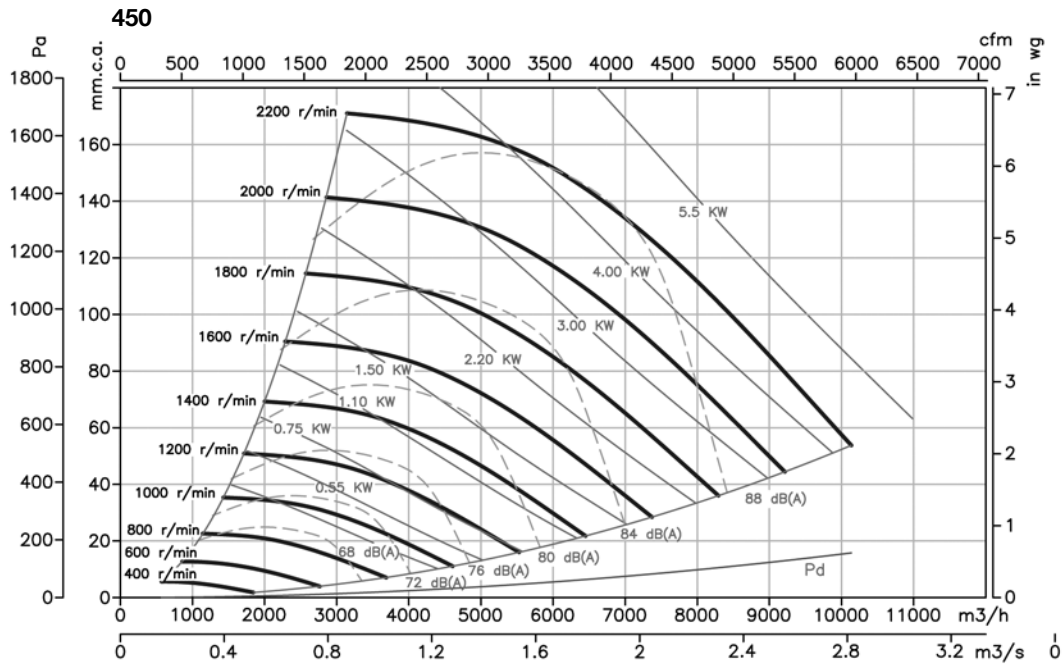
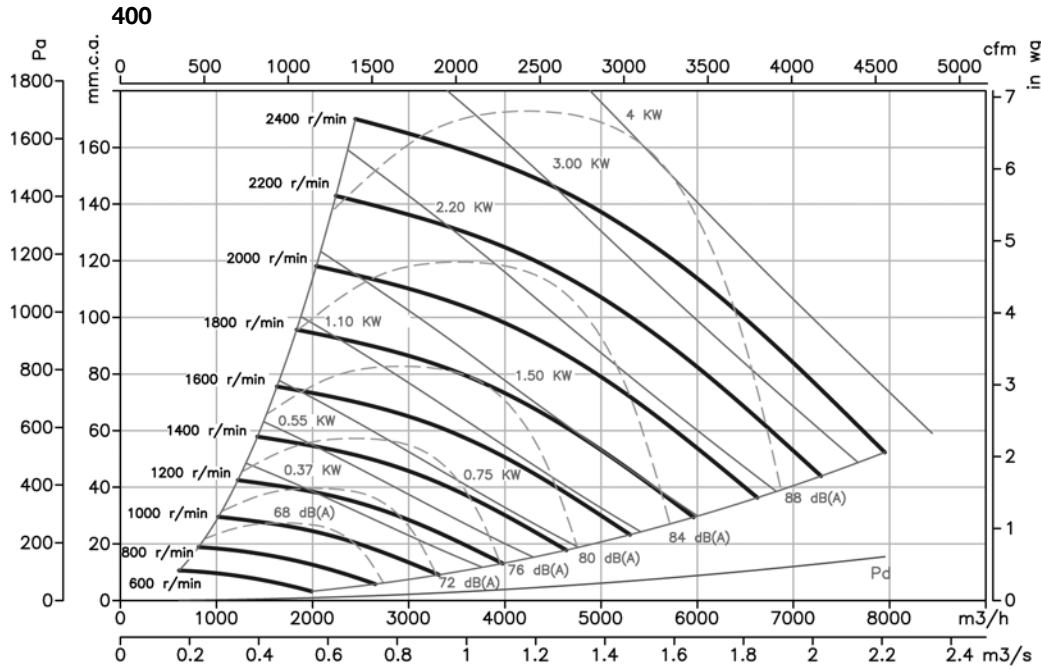

Characteristic curves

Q = Airflow in m³/h, m³/s and cfm.

Pe = Static pressure in mm.w.c., Pa and in wg.

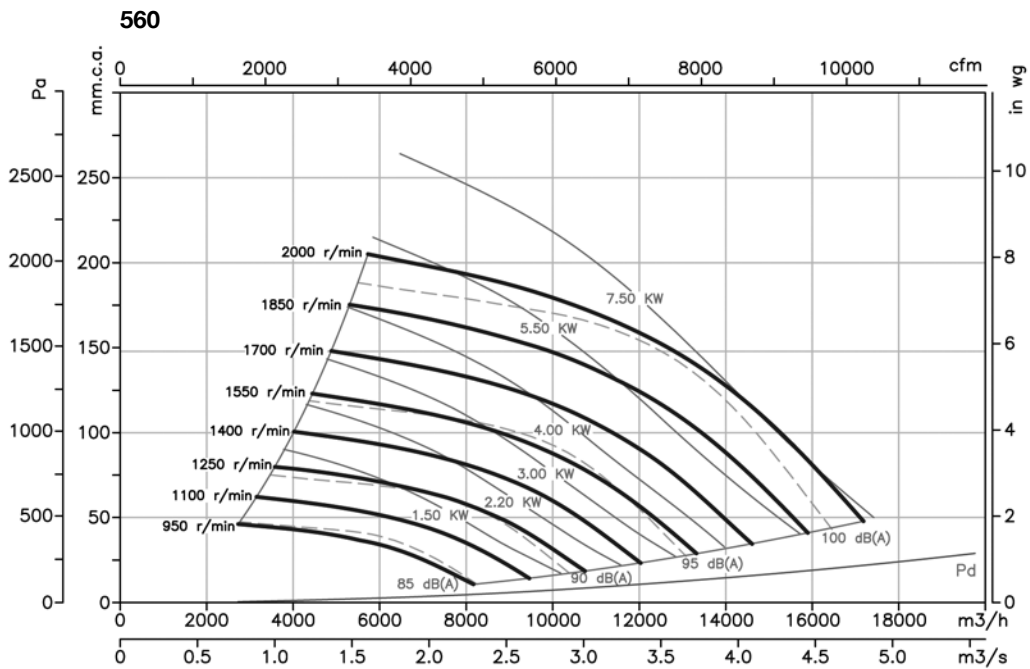
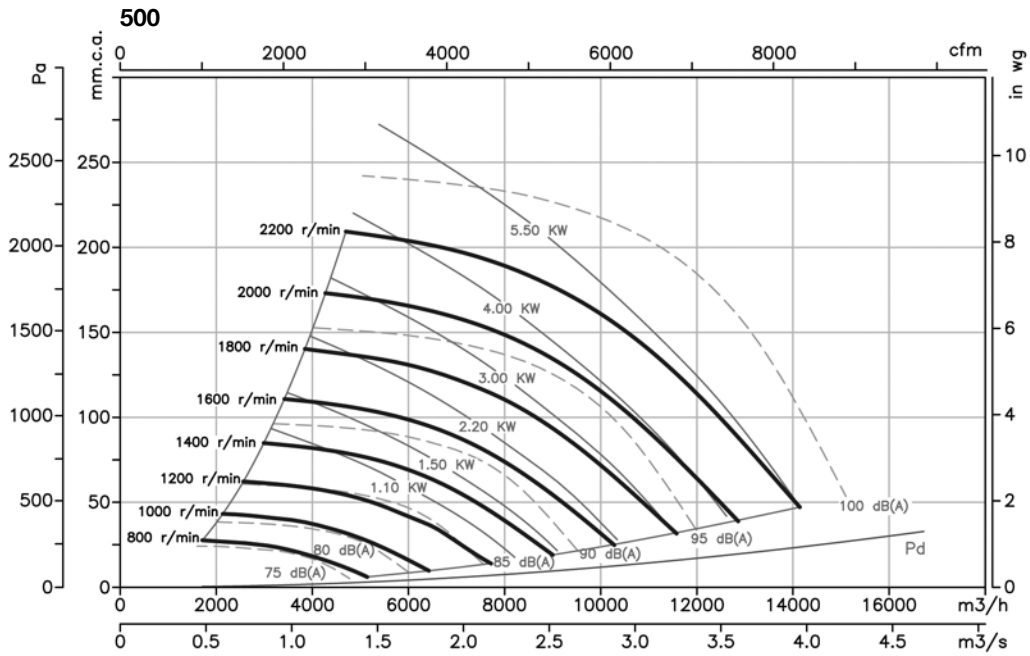

Characteristic curves

Q = Airflow in m³/h, m³/s and cfm.

Pe = Static pressure in mm.w.c., Pa and in wg.

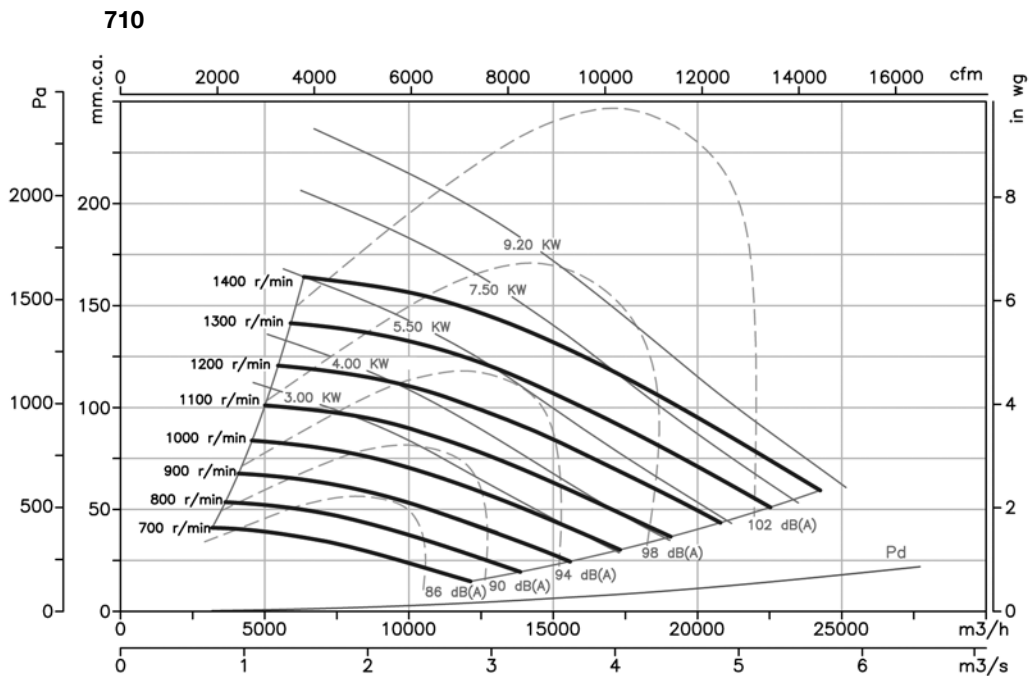
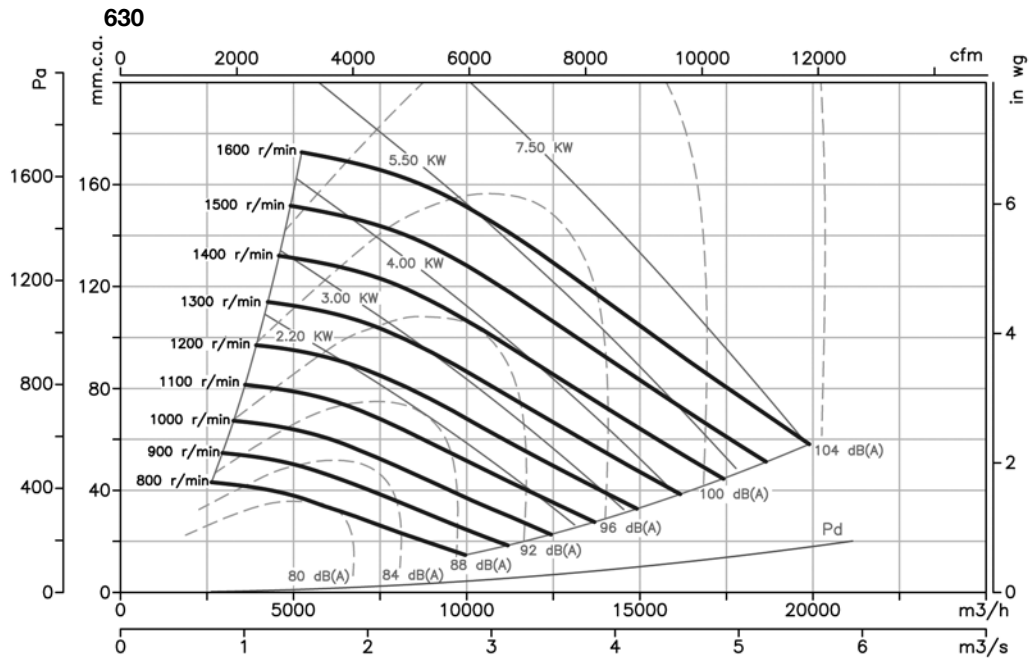

Characteristic curves

Q = Airflow in m³/h, m³/s and cfm.

Pe = Static pressure in mm.w.c., Pa and in wg.

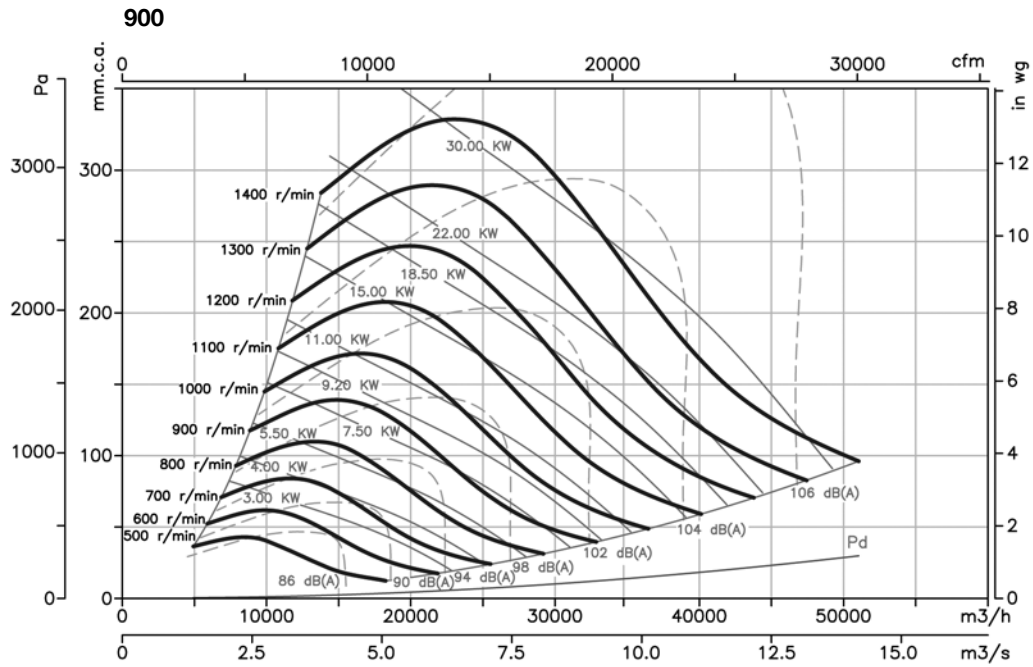
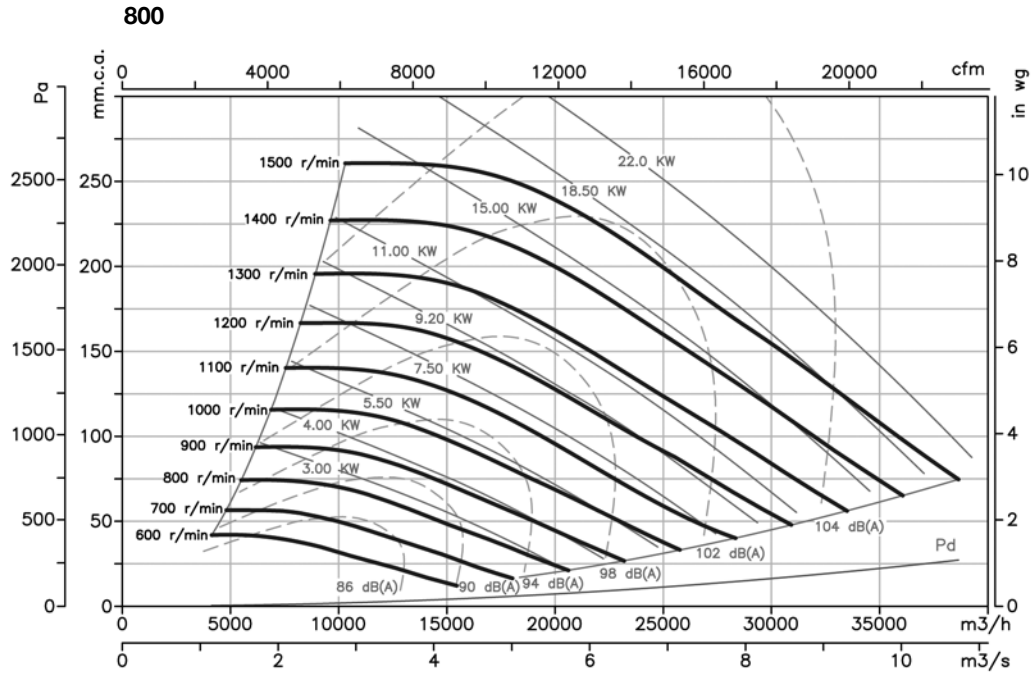

Characteristic curves

Q = Airflow in m³/h, m³/s and cfm.

Pe = Static pressure in mm.w.c., Pa and in wg.

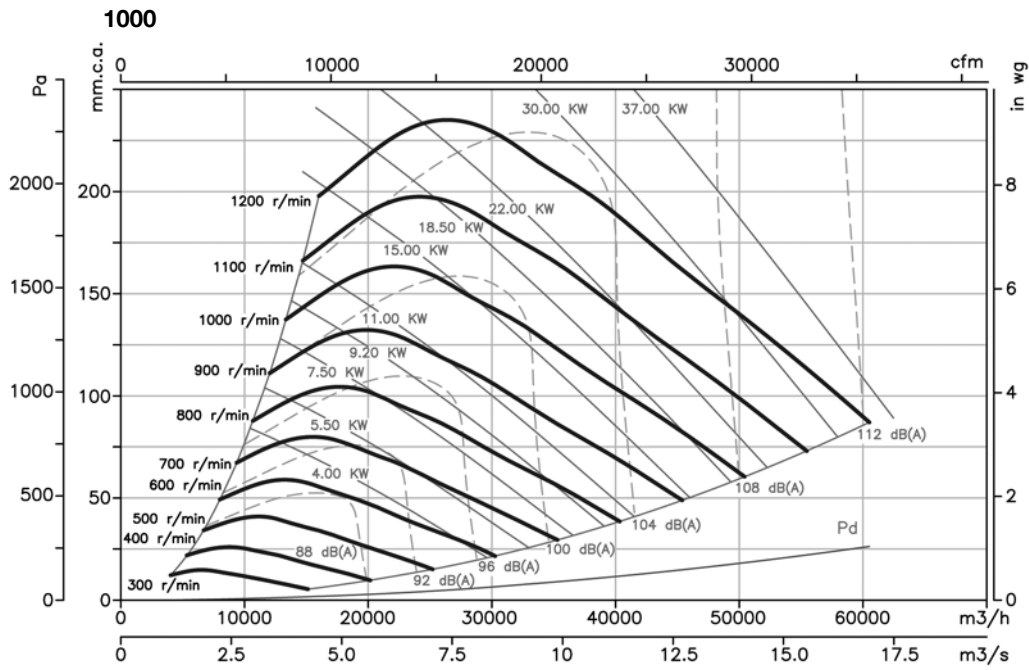

Accessories



CJBDT/CBDT

Double inlet extraction units and centrifugal fans with direct motor for working inside fire danger zones 400°C/2h and 300°C/1h, with possibility of single-phase motor



Double inlet extraction units and centrifugal fans with direct motor for working inside fire danger zones 400°C/2h, with possibility of single-phase motor



Fan:

- Galvanized sheet steel casing
- Impeller with forward-facing blades made from galvanized sheet steel
- Outside connecting box.
- Anti-vibration dampers (CJBDT)
- Approval according to Standard EN12101-3:2002, certificate no.: 370-CPD-0580

Motor:

- Class H motors, ongoing use S1 and emergency use S2, with ball bearings, IP55 protection, and one- or two- speed depending on the model.
- Single-phase 230V 50 Hz. and Three-phase 230/400V.50Hz. (up to 4CV.) and 400/690V.-50Hz. (power over 4CV.)
- Max. air temperature to transport: S1 Service -20°C + 60°C for ongoing use, S2 Service 300°C/2h, 400°C/2h

Finish:

- Anticorrosive galvanized sheet steel.

On request:

- Fans with circular inlet
- Fans with vertical outlet



Outside connecting box and base stands



Single-phase motors, 400°C/2h

Order code

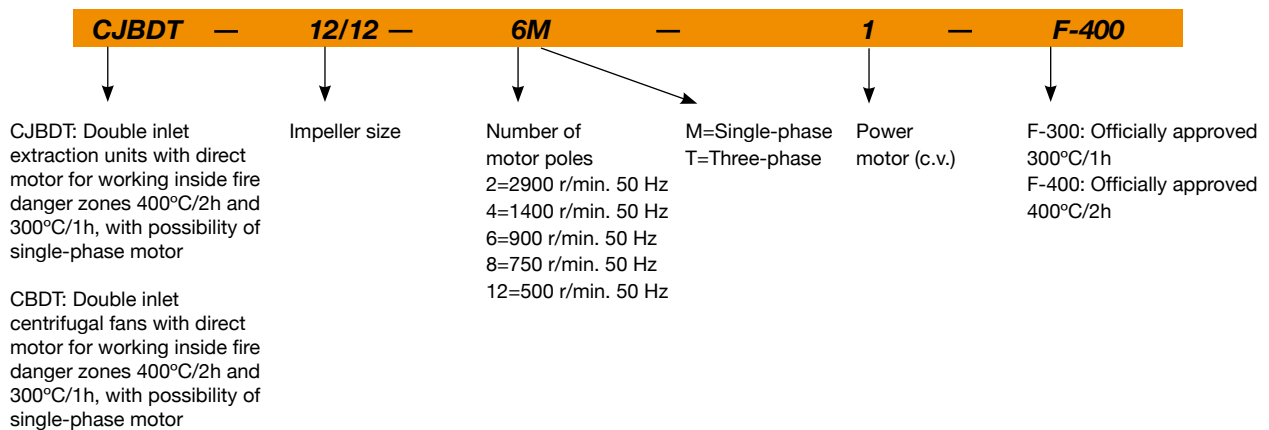

Technical characteristics

Model		Speed (r/min)	Maximum admissible current (A)			Installed Power (kW)	Maximum Airflow (m³/h)	Sound pressure level dB(A)		Approx. weight (Kg)	
			230V	400V	690V			CJBDT	CBDT	CJBDT	CBDT
CJBDT-9/9-4T	CBDT-9/9-4T	1420	2.90	1.70		0.55	3000	64	66	44	24
CJBDT-9/9-4/8T	CBDT-9/9-4/8T	1440 / 710		1.76 / 0.76		0.55 / 0.15	3000 / 1750	64 / 51	66 / 53	45	25
CJBDT-9/9-4M	CBDT-9/9-4M	1410	4.10			0.55	3000	64	66	44	23
CJBDT-9/9-6T	CBDT-9/9-6T	920	1.50	0.90		0.25	2100	60	61	42	22
CJBDT-9/9-6M	CBDT-9/9-6M	900	2.20			0.25	2100	60	61	42	21
CJBDT-10/10-4T	CBDT-10/10-4T	1420	2.90	1.70		0.55	3450	67	68	49	26
CJBDT-10/10-4/8T	CBDT-10/10-4/8T	1440 / 710		1.76 / 0.76		0.55 / 0.15	3450 / 1750	67 / 54	68 / 55	50	27
CJBDT-10/10-4M	CBDT-10/10-4M	1410	4.10			0.55	3450	67	68	49	25
CJBDT-10/10-6T	CBDT-10/10-6T	920	1.50	0.90		0.25	2250	63	64	47	24
CJBDT-10/10-6M	CBDT-10/10-6M	900	2.20			0.25	2250	63	64	47	23
CJBDT-12/12-6T-1	CBDT-12/12-6T-1	940	4.40	2.60		0.75	4800	64	65	69	37
CJBDT-12/12-6/12T-1	CBDT-12/12-6/12T-1	935 / 430		2.50 / 1.03		0.75 / 0.15	4800 / 2600	64 / 52	65 / 53	72	41
CJBDT-12/12-6M-1	CBDT-12/12-6M-1	920	5.80			0.75	4800	64	65	69	37
CJBDT-12/12-6T-1,5	CBDT-12/12-6T-1,5	945	6.40	3.70		1.10	6200	65	67	71	39
CJBDT-12/12-6/12T-1,5	CBDT-12/12-6/12T-1,5	940 / 450		3.30 / 1.20		1.10 / 0.18	6200 / 3250	65 / 53	67 / 55	75	44
CJBDT-12/12-6M-1,5	CBDT-12/12-6M-1,5	920	8.40			1.10	6200	65	67	71	39
CJBDT-15/15-6T	CBDT-15/15-6T	950	10.30	5.90		2.20	8250	67	68	110	68
CJBDT-15/15-6/12T	CBDT-15/15-6/12T	940 / 470		5.60 / 2.20		2.20 / 0.37	8250 / 4600	67 / 54	68 / 55	116	74
CJBDT-18/18-6T	CBDT-18/18-6T	970		11.00	6.35	4.00	11800	67	69	175	109
CJBDT-18/18-6/12T	CBDT-18/18-6/12T	970 / 480		11.30 / 4.20		4.00 / 0.65	11800 / 6600	67 / 54	69 / 56	183	117
CJBDT-20/20-6T	CBDT-20/20-6T	970		14.00		5.50	14300	68	70	247	151
CJBDT-20/20-6/12T	CBDT-20/20-6/12T	970 / 480		13.70 / 5.60		5.50 / 1.00	14300 / 9700	68 / 55	70 / 57	255	159
CJBDT-22/22-6T	CBDT-22/22-6T	960		18.40	10.60	7.50	18050	69	71	309	190
CJBDT-22/22-6/12T	CBDT-22/22-6/12T	970 / 480		19.00 / 8.00		7.50 / 1.40	18050 / 11800	69 / 56	71 / 58	319	200

Acoustic features

The specified values are determined according to free field measurements of pressure and sound levels in dB(A) at an equivalent distance of twice the fan's span plus the impeller's diameter, with a minimum of 1.5 m.

Sound power Lw(A) spectrum in dB(A) via frequency band in Hz.

CBDT Model	63	125	250	500	1000	2000	4000	8000	CJBDT Model	63	125	250	500	1000	2000	4000	8000
9/9-4	46	56	64	68	73	72	69	61	9/9-4	51	66	70	69	68	65	65	55
9/9-6	43	54	59	66	67	67	62	56	9/9-6	47	62	66	65	64	61	61	51
9/9-8	34	45	51	57	60	59	55	48	9/9-8	44	51	57	57	54	50	53	48
10/10-4	48	58	66	70	75	74	71	63	10/10-4	54	69	73	72	71	68	68	58
10/10-6	46	57	62	69	70	70	65	59	10/10-6	50	65	69	68	67	64	64	54
10/10-8	36	47	53	59	62	61	57	50	10/10-8	47	54	60	60	57	53	56	51
12/12-6-1	47	58	63	70	71	71	66	60	12/12-6-1	51	66	70	69	68	65	65	55
12/12-6-1,5	49	60	65	72	73	73	68	62	12/12-6-1,5	52	67	71	70	69	66	66	56
12/12-12-1	34	45	51	57	60	59	55	48	12/12-12-1	45	52	58	58	55	51	54	49
12/12-12-1,5	46	53	59	59	56	52	55	50	12/12-12-1,5	46	53	59	59	56	52	55	50
15/15-6	63	72	74	76	71	70	64	55	15/15-6	63	72	74	76	71	70	64	55
15/15-12	51	54	63	60	58	60	60	48	15/15-12	51	54	63	60	58	60	60	48
18/18-6	64	74	76	78	73	72	66	57	18/18-6	64	74	76	78	73	72	66	57
18/18-12	53	56	65	62	60	62	62	50	18/18-12	53	56	65	62	60	62	62	50
20/20-6	67	77	79	80	76	74	69	60	20/20-6	67	77	79	80	76	74	69	60
20/20-12	55	59	68	65	63	65	64	53	20/20-12	55	59	68	65	63	65	64	53
22/22-6	69	79	81	83	78	77	71	62	22/22-6	69	79	81	83	78	77	71	62
22/22-12	58	61	70	67	65	67	67	55	22/22-12	58	61	70	67	65	67	67	55

Dimensions in mm

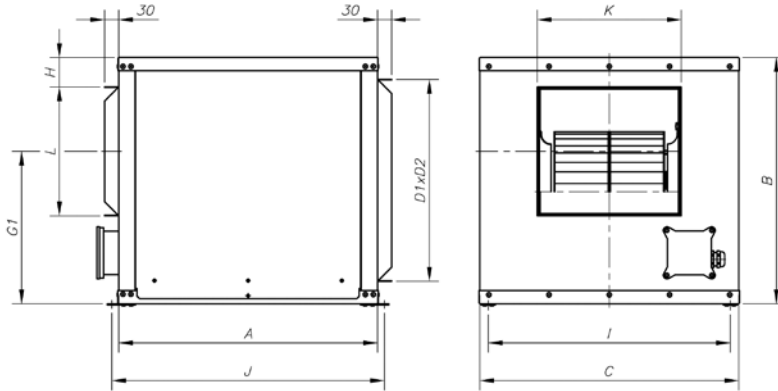

Model	A	B	C	D1xD2	G1	H	I	J	K	L
CJBDT-9/9	500	522	550	428x456	323	62.5	514	573	306	273
CJBDT-10/10	600	575	600	480x505	358.5	67.5	564	623	334	298
CJBDT-12/12	650	650	700	555x605	414.5	60.5	664	673	394	350
CJBDT-15/15	755	755	800	660x705	471.5	77.5	764	780	480	412
CJBDT-18/18	1000	875	1000	804x904	582	73.5	940	1047	565	489
CJBDT-20/20	1200	1175	1100	1070x1000	701	167.5	1040	1247	610	613
CJBDT-22/22	1280	1250	1250	1154x1154	739.5	158.5	1190	1327	664	704

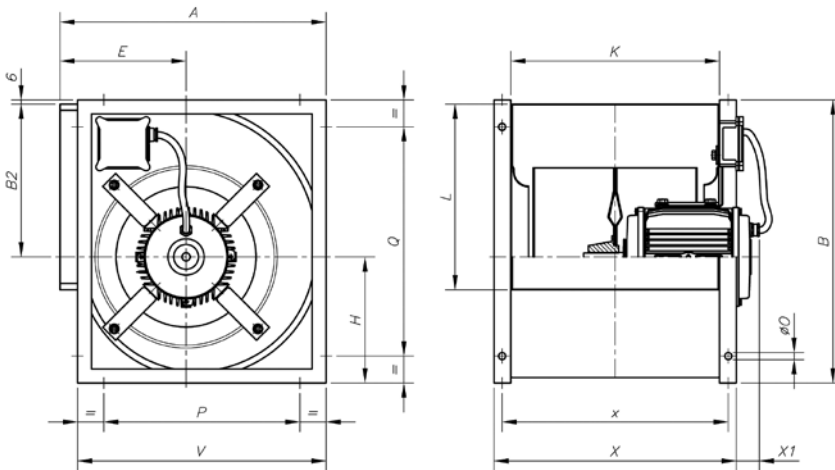

Location of terminal board:

CBDT-9/9
10/10
12/12
15/15

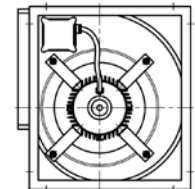

CBDT-18/18
20/20
22/22

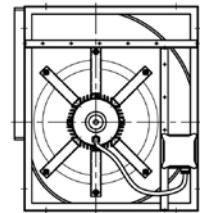

Model	A	B	B2	E	H	K	L	P	Q	V	X	X1	x	ØO
CBDT-9/9	380	404	218	180	180	298	265	280	327	355	346	49	323	10
CBDT-10/10	432	452	245	207	201	326	290	326	377	402	374	33	350	10
CBDT-12/12	508	534	292	236	236	386	342	384	443	475	444	57	416	10
CBDT-15/15	586	622	343	268	273	473	404	460	531	553	532	58	504	10
CBDT-18/18	701	754	414	320	334	556	480	553	641	666	26	85	592	10
CBDT-20/20	839	935	523	372	406	602	604	595	735	795	682	58	642	12
CBDT-22/22	907	1019	571	399	442	655	695	663	819	863	735	105	695	12

Characteristic curves

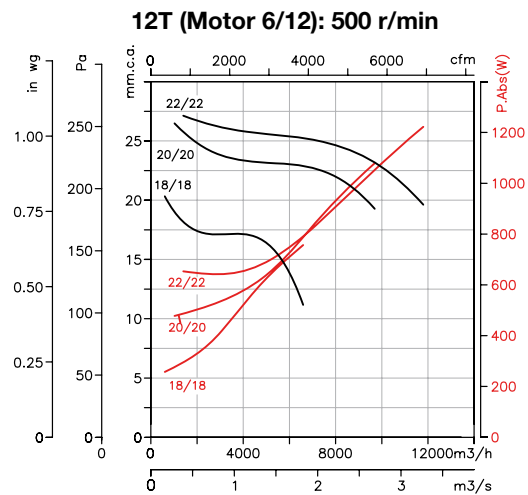
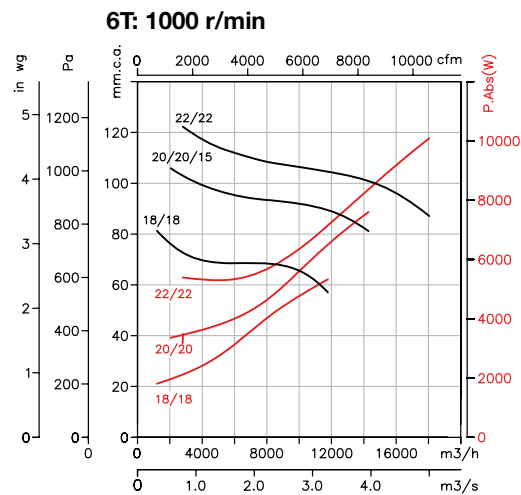
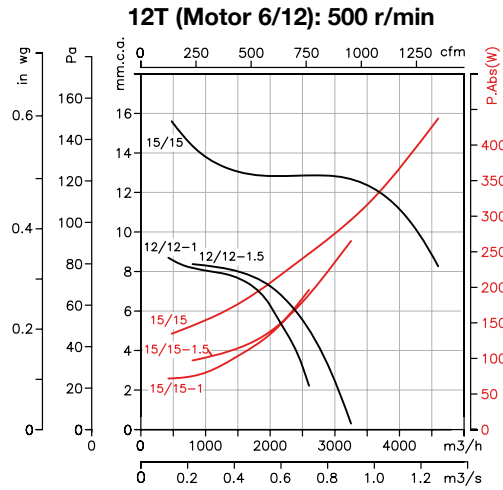
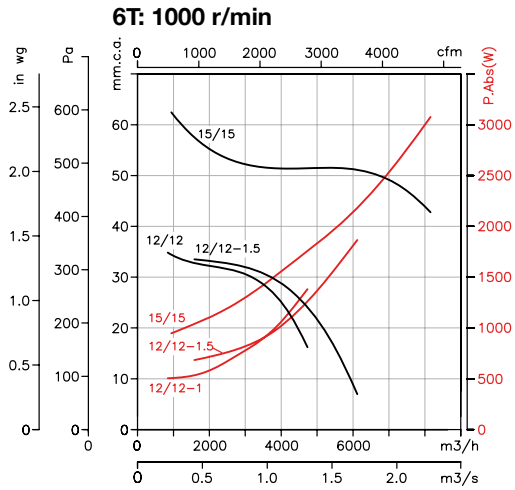
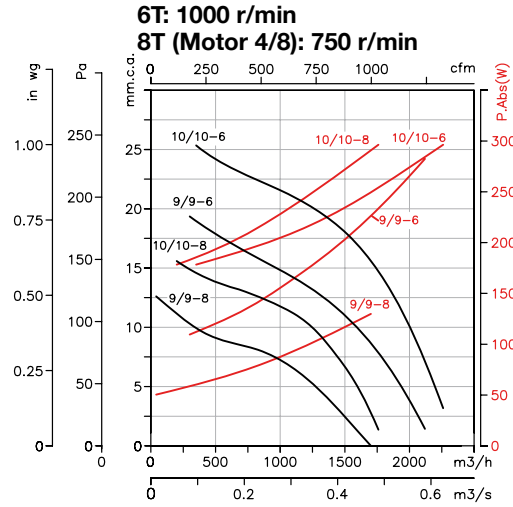
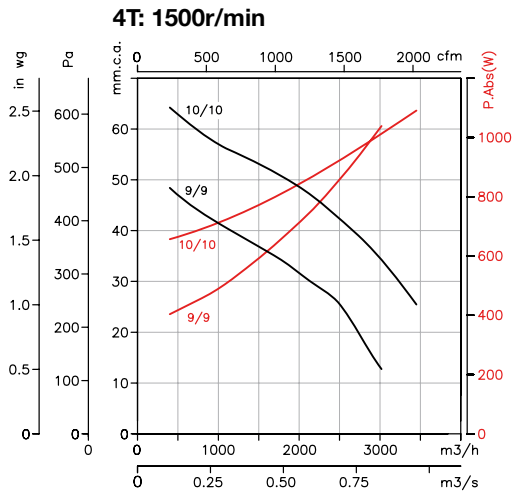

Accessories



CJTX-C

400°C/2h belt-driven extraction units with double-inlet fan



Exclusive system of anchoring

400°C/2h extraction units with motor and belt-driven inside the plate to work outside fire danger zones.

Fan:

- Galvanized sheet steel structure.
- Impeller with forward-facing blades made from galvanised sheet steel
- Approval according to Standard EN-12101-3-2002, certification No.: 0370-CPD-0468
- Linear air circulation

Motor:

- Class F motors with ball bearings, IP55 protection, one- or two-speed depending on the model
- Three-phase 230/400V.-50Hz. (up to 5.5CV) and 400/690V.-50Hz. (power over 5.5CV)
- Max. air temperature to transport: S1 Service -20°C+ 120°C for ongoing use,

S2 Service 200°C/2h, 300°C/2h and 400°C/2h

Finish:

- Anticorrosive galvanized sheet steel.

On request:

- Fans with vertical outlet



Order code



400°C/2h belt-driven extraction units with double-inlet fan

Impeller size

Power motor (c.v.)

Reference with 2V: Two-speed fan

F-400: Officially approved 400°C/2h

For Service S2: 200°C/2h, 300°C/2h and 400°C/2h

Technical characteristics

Model	Speed (r/min)	Maximum admissible current (A)			Installed Power (kW)	Maximum Airflow (m³/h)	Sound pressure level dB(A)	Approx. weight (Kg)
		230V	400V (A)	690V				
CJTX-C-7/7-0,25	1000	1.03	0.59		0.18	1600	58	53
CJTX-C-7/7-0,33	1200	1.30	0.75		0.25	1825	60	54
CJTX-C-7/7-0,33 2V	1200 / 600		0.70 / 0.30		0.25 / 0.10	1825 / 915	60 / 45	54
CJTX-C-7/7-0,5	1400	1.85	1.06		0.37	2100	64	54
CJTX-C-7/7-0,5 2V	1400 / 700		1.05 / 0.50		0.37 / 0.11	2100 / 1050	64 / 49	57
CJTX-C-7/7-0,75	1600	2.59	1.49		0.55	2350	67	58
CJTX-C-7/7-0,75 2V	1600 / 800		1.70 / 0.80		0.55 / 0.19	2350 / 1175	67 / 52	58
CJTX-C-7/7-1	1800	2.96	1.71		0.75	2600	69	62
CJTX-C-7/7-1 2V	1800 / 900		2.00 / 0.90		0.75 / 0.20	2600 / 1300	69 / 54	61
CJTX-C-9/9-0,33	850	1.30	0.75		0.25	2300	58	65
CJTX-C-9/9-0,33 2V	850 / 425		0.70 / 0.30		0.25 / 0.10	2300 / 1150	58 / 43	65
CJTX-C-9/9-0,5	960	1.85	1.06		0.37	2800	61	66
CJTX-C-9/9-0,5 2V	960 / 480		1.05 / 0.50		0.37 / 0.11	2800 / 1400	61 / 46	67
CJTX-C-9/9-0,75	1060	2.59	1.49		0.55	3200	65	69
CJTX-C-9/9-0,75 2V	1060 / 530		1.70 / 0.80		0.55 / 0.19	3200 / 1600	65 / 50	69
CJTX-C-9/9-1	1200	2.96	1.71		0.75	3500	67	73
CJTX-C-9/9-1 2V	1200 / 600		2.00 / 0.90		0.75 / 0.20	3500 / 1750	67 / 52	72
CJTX-C-9/9-1,5	1340	4.38	2.53		1.10	4100	70	80
CJTX-C-9/9-1,5 2V	1340 / 670		2.90 / 1.30		1.10 / 0.25	4100 / 2050	70 / 55	74
CJTX-C-9/9-2	1500	5.53	3.19		1.50	4400	72	84
CJTX-C-9/9-2 2V	1500 / 750		3.50 / 1.50		1.50 / 0.37	4400 / 2200	72 / 57	76
CJTX-C-10/10-0,33	660	1.30	0.75		0.25	2800	57	77

Technical characteristics

Model	Speed (r/min)	Maximum admissible current (A)			Installed Power (kW)	Maximum Airflow (m³/h)	Sound pressure level dB(A)	Approx. weight (Kg)
		230V	400V (A)	690V				
CJTX-C-10/10-0.33 2V	660 / 330		0.70 / 0.30		0.25 / 0.10	2800 / 1400	57 / 42	77
CJTX-C-10/10-0.5	800	1.85	1.06		0.37	3300	61	77
CJTX-C-10/10-0.5 2V	800 / 400		1.05 / 0.50		0.37 / 0.11	3300 / 1650	61 / 46	79
CJTX-C-10/10-0.75	880	2.59	1.49		0.55	3800	63	81
CJTX-C-10/10-0.75 2V	880 / 440		1.70 / 0.80		0.55 / 0.19	3800 / 1900	63 / 48	81
CJTX-C-10/10-1	1000	2.96	1.71		0.75	4200	65	85
CJTX-C-10/10-1 2V	1000 / 500		2.00 / 0.90		0.75 / 0.20	4200 / 2100	65 / 50	84
CJTX-C-10/10-1.5	1130	4.38	2.53		1.10	4800	68	92
CJTX-C-10/10-1.5 2V	1130 / 565		2.90 / 1.30		1.10 / 0.25	4800 / 2400	68 / 53	85
CJTX-C-10/10-2	1270	5.53	3.19		1.50	5300	71	94
CJTX-C-10/10-2 2V	1270 / 635		3.50 / 1.50		1.50 / 0.37	5300 / 2650	71 / 56	86
CJTX-C-10/10-3	1450	8.40	4.85		2.20	5900	74	89
CJTX-C-10/10-3 2V	1450 / 725		4.90 / 1.70		2.20 / 0.45	5900 / 2950	74 / 59	93
CJTX-C-12/12-0.5	600	1.85	1.06		0.37	4200	60	96
CJTX-C-12/12-0.5 2V	600 / 300		1.05 / 0.50		0.37 / 0.11	4200 / 2100	60 / 45	98
CJTX-C-12/12-0.75	700	2.59	1.49		0.55	4600	63	99
CJTX-C-12/12-0.75 2V	700 / 350		1.70 / 0.80		0.55 / 0.19	4600 / 2300	63 / 48	100
CJTX-C-12/12-1	800	2.96	1.71		0.75	5100	65	104
CJTX-C-12/12-1 2V	800 / 400		2.00 / 0.90		0.75 / 0.20	5100 / 2550	65 / 50	103
CJTX-C-12/12-1.5	880	4.38	2.53		1.10	5700	68	111
CJTX-C-12/12-1.5 2V	880 / 440		2.90 / 1.30		1.10 / 0.25	5700 / 2850	68 / 53	104
CJTX-C-12/12-2	1020	5.53	3.19		1.50	6400	70	113
CJTX-C-12/12-2 2V	1020 / 510		3.50 / 1.50		1.50 / 0.37	6400 / 3200	70 / 55	105
CJTX-C-12/12-3	1140	8.40	4.85		2.20	7400	73	107
CJTX-C-12/12-3 2V	1140 / 570		4.90 / 1.70		2.20 / 0.45	7400 / 3700	73 / 58	110
CJTX-C-12/12-4	1250	11.22	6.48		3.00	8200	75	115
CJTX-C-12/12-4 2V	1250 / 625		6.50 / 2.30		3.00 / 0.60	8200 / 4100	75 / 60	118
CJTX-C-15/15-0.75	530	2.59	1.49		0.55	4700	59	126
CJTX-C-15/15-0.75 2V	530 / 265		1.70 / 0.80		0.55 / 0.19	4700 / 2350	59 / 44	126
CJTX-C-15/15-1	560	2.96	1.71		0.75	6000	61	130
CJTX-C-15/15-1 2V	560 / 280		2.00 / 0.90		0.75 / 0.20	6000 / 3000	61 / 46	129
CJTX-C-15/15-1.5	630	4.38	2.53		1.10	7000	64	138
CJTX-C-15/15-1.5 2V	630 / 315		2.90 / 1.30		1.10 / 0.25	7000 / 3500	64 / 49	131
CJTX-C-15/15-2	700	5.53	3.19		1.50	7800	66	141
CJTX-C-15/15-2 2V	700 / 350		3.50 / 1.50		1.50 / 0.37	7800 / 3900	66 / 51	133
CJTX-C-15/15-3	800	8.40	4.85		2.20	9000	69	135
CJTX-C-15/15-3 2V	800 / 400		4.90 / 1.70		2.20 / 0.45	9000 / 4500	69 / 54	140
CJTX-C-15/15-4	880	11.22	6.48		3.00	10000	72	144
CJTX-C-15/15-4 2V	880 / 440		6.50 / 2.30		3.00 / 0.60	10000 / 5000	72 / 57	147
CJTX-C-15/15-5.5	970	14.98	8.65		4.00	11000	73	145
CJTX-C-15/15-5.5 2V	970 / 485		8.20 / 2.90		4.00 / 0.80	11000 / 5500	73 / 58	151
CJTX-C-18/18-1	460	2.96	1.71		0.75	7500	60	163
CJTX-C-18/18-1 2V	460 / 230		2.00 / 0.90		0.75 / 0.20	7500 / 3750	60 / 45	163
CJTX-C-18/18-1.5	510	4.38	2.53		1.10	9000	61	171
CJTX-C-18/18-1.5 2V	510 / 255		2.90 / 1.30		1.10 / 0.25	9000 / 4500	61 / 46	165
CJTX-C-18/18-2	540	5.53	3.19		1.50	10800	64	175
CJTX-C-18/18-2 2V	540 / 270		3.50 / 1.50		1.50 / 0.37	10800 / 5400	64 / 49	167
CJTX-C-18/18-3	610	8.40	4.85		2.20	12500	67	170
CJTX-C-18/18-3 2V	610 / 305		4.90 / 1.70		2.20 / 0.45	12500 / 6250	67 / 52	173
CJTX-C-18/18-4	680	11.22	6.48		3.00	14000	70	177
CJTX-C-18/18-4 2V	680 / 340		6.50 / 2.30		3.00 / 0.60	14000 / 7000	70 / 55	180
CJTX-C-18/18-5.5	750	14.98	8.65		4.00	15000	72	178
CJTX-C-18/18-5.5 2V	750 / 375		8.20 / 2.90		4.00 / 0.80	15000 / 7500	72 / 57	184
CJTX-C-18/18-7.5	850		11.40	6.60	5.50	16500	74	188
CJTX-C-18/18-7.5 2V	850 / 425		11.80 / 3.80		5.50 / 1.10	16500 / 8250	74 / 59	204
CJTX-C-18/18-10	930		14.80	8.50	7.50	18000	77	202
CJTX-C-18/18-10 2V	930 / 465		15.30 / 5.40		7.50 / 1.50	18000 / 9000	77 / 62	213
CJTX-C-20/20-2	450	5.53	3.19		1.50	13000	64	276
CJTX-C-20/20-2 2V	450 / 225		3.50 / 1.50		1.50 / 0.37	13000 / 6500	64 / 49	268
CJTX-C-20/20-3	530	8.40	4.85		2.20	15000	68	270
CJTX-C-20/20-3 2V	530 / 265		4.90 / 1.70		2.20 / 0.45	15000 / 7500	68 / 53	274
CJTX-C-20/20-4	580	11.22	6.48		3.00	16300	70	277
CJTX-C-20/20-4 2V	580 / 290		6.50 / 2.30		3.00 / 0.60	16300 / 8150	70 / 55	280
CJTX-C-20/20-5.5	660	14.98	8.65		4.00	18000	72	279

Technical characteristics

Model	Speed (r/min)	Maximum admissible current (A)			Installed Power (kW)	Maximum Airflow (m³/h)	Sound pressure level dB(A)	Approx. weight (Kg)
		230V	400V (A)	690V				
CJTX-C-20/20-5,5 2V	660 / 330		8.20 / 2.90		4.00 / 0.80	18000 / 9000	72 / 57	285
CJTX-C-20/20-7,5	740		11.40	6.60	5.50	20500	74	289
CJTX-C-20/20-7,5 2V	740 / 370		11.80 / 3.80		5.50 / 1.10	20500 / 10250	74 / 59	305
CJTX-C-20/20-10	815		14.80	8.50	7.50	22500	77	304
CJTX-C-20/20-10 2V	815 / 408		15.30 / 5.40		7.50 / 1.50	22500 / 11250	77 / 62	314
CJTX-C-22/22-2	380	5.53	3.19		1.50	14000	62	318
CJTX-C-22/22-2 2V	380 / 190		3.50 / 1.50		1.50 / 0.37	14000 / 7000	62 / 47	310
CJTX-C-22/22-3	430	8.40	4.85		2.20	16000	64	312
CJTX-C-22/22-3 2V	430 / 215		4.90 / 1.70		2.20 / 0.45	16000 / 8000	64 / 49	316
CJTX-C-22/22-4	480	11.22	6.48		3.00	18000	68	320
CJTX-C-22/22-4 2V	480 / 240		6.50 / 2.30		3.00 / 0.60	18000 / 9000	68 / 53	323
CJTX-C-22/22-5,5	520	14.98	8.65		4.00	20000	69	323
CJTX-C-22/22-5,5 2V	520 / 260		8.20 / 2.90		4.00 / 0.80	20000 / 10000	69 / 54	329
CJTX-C-22/22-7,5	580		11.40	6.60	5.50	22500	72	333
CJTX-C-22/22-7,5 2V	580 / 290		11.80 / 3.80		5.50 / 1.10	22500 / 11250	72 / 57	350
CJTX-C-22/22-10	650		14.80	8.50	7.50	25000	74	346
CJTX-C-22/22-10 2V	650 / 325		15.30 / 5.40		7.50 / 1.50	25000 / 12500	74 / 59	357
CJTX-C-22/22-15	740		21.00	12.10	11.00	28000	77	358
CJTX-C-22/22-15 2V	740 / 370		23.20 / 8.70		10.50 / 2.80	28000 / 14000	77 / 62	389
CJTX-C-22/22-20	780		28.60	16.50	15.00	31000	79	424
CJTX-C-22/22-20 2V	780 / 390		31.72 / 11.75		15.00 / 3.80	31000 / 15500	79 / 64	413
CJTX-C-25/25-3	340	8.40	4.85		2.20	20000	66	369
CJTX-C-25/25-3 2V	340 / 170		4.90 / 1.70		2.20 / 0.45	20000 / 10000	66 / 51	372
CJTX-C-25/25-4	380	11.22	6.48		3.00	22000	68	376
CJTX-C-25/25-4 2V	380 / 190		6.50 / 2.30		3.00 / 0.60	22000 / 11000	68 / 53	379
CJTX-C-25/25-5,5	420	14.98	8.65		4.00	24000	70	377
CJTX-C-25/25-5,5 2V	420 / 210		8.20 / 2.90		4.00 / 0.80	24000 / 12000	70 / 55	383
CJTX-C-25/25-7,5	470		11.40	6.60	5.50	26500	73	393
CJTX-C-25/25-7,5 2V	470 / 235		11.80 / 3.80		5.50 / 1.10	26500 / 13250	73 / 58	409
CJTX-C-25/25-10	510		14.80	8.50	7.50	29000	75	401
CJTX-C-25/25-10 2V	510 / 255		15.30 / 5.40		7.50 / 1.50	29000 / 14500	75 / 60	412
CJTX-C-25/25-15	570		21.00	12.10	11.00	34000	78	419
CJTX-C-25/25-15 2V	570 / 285		23.20 / 8.70		10.50 / 2.80	34000 / 17000	78 / 63	450
CJTX-C-25/25-20	630		28.60	16.50	15.00	38000	80	482
CJTX-C-25/25-20 2V	630 / 315		31.72 / 11.75		15.00 / 3.80	38000 / 19000	80 / 65	471
CJTX-C-30/28-3	250	8.40	4.85		2.20	25000	64	502
CJTX-C-30/28-3 2V	250 / 125		4.90 / 1.70		2.20 / 0.45	25000 / 12500	64 / 49	507
CJTX-C-30/28-4	280	11.22	6.48		3.00	27000	66	516
CJTX-C-30/28-4 2V	280 / 140		6.50 / 2.30		3.00 / 0.60	27000 / 13500	66 / 51	519
CJTX-C-30/28-5,5	340	14.98	8.65		4.00	29000	68	517
CJTX-C-30/28-5,5 2V	340 / 170		8.20 / 2.90		4.00 / 0.80	29000 / 14500	68 / 53	523
CJTX-C-30/28-7,5	360		11.40	6.60	5.50	32500	71	530
CJTX-C-30/28-7,5 2V	360 / 180		11.80 / 3.80		5.50 / 1.10	32500 / 16250	71 / 56	546
CJTX-C-30/28-10	410		14.80	8.50	7.50	36000	73	545
CJTX-C-30/28-10 2V	410 / 205		15.30 / 5.40		7.50 / 1.50	36000 / 18000	73 / 58	556
CJTX-C-30/28-15	480		21.00	12.10	11.00	40000	76	557
CJTX-C-30/28-15 2V	480 / 240		23.20 / 8.70		10.50 / 2.80	40000 / 20000	76 / 61	588
CJTX-C-30/28-20	520		28.60	16.50	15.00	45000	78	627
CJTX-C-30/28-20 2V	520 / 260		31.72 / 11.75		15.00 / 3.80	45000 / 22500	78 / 63	616
CJTX-C-30/28-25	550		36.00	20.80	18.50	49000	79	609
CJTX-C-30/28-25 2V	550 / 275		33.00 / 11.00		17.00 / 3.40	49000 / 24500	79 / 64	643

Dimensions in mm

Standard supply horizontal outlet (H): LG -90

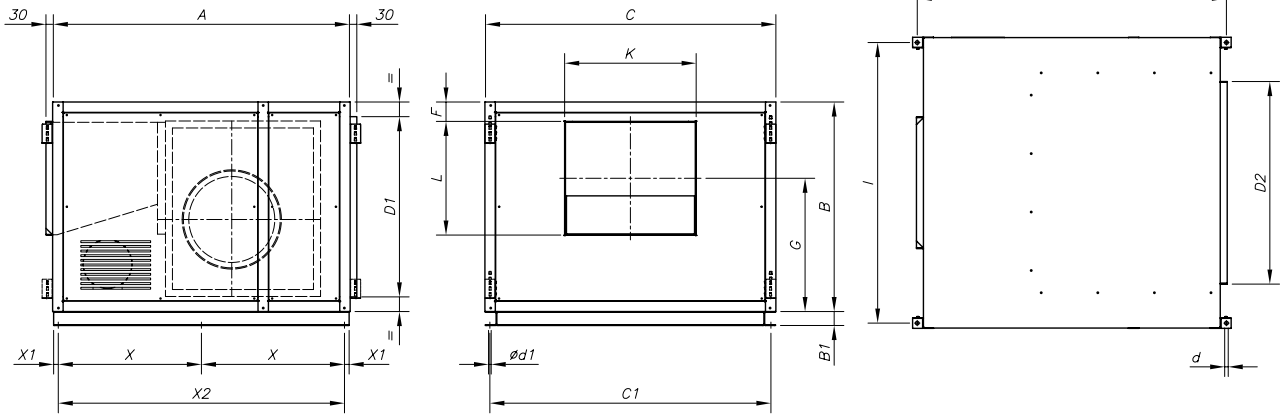

Model	A	B	B1	C	C1	Ød	Ød1	D1	D2	F	G	H	I	K	L	X	X1	X2
CJTX-C-7/7	700	480	-	730	695	10.5	9	354	470	60	532	750	685	239	216	-	-	-
CJTX-C-9/9	785	592	-	759	716	10.5	9	466	490	43	607	835	714	305	270	-	-	-
CJTX-C-10/10	860	618	-	825	782	10.5	9	492	520	28.5	683.5	910	780	334	296	-	-	-
CJTX-C-12/12	970	680	-	945	902	10.5	9	554	620	38.5	756.5	1020	900	395	350	-	-	-
CJTX-C-15/15	1100	776	-	1100	1057	10.5	9	650	720	41	853.5	1150	1055	483	411	-	-	-
CJTX-C-18/18	1278	900	60	1250	1207	10.5	11	774	870	41	993	1328	1205	565	488	614.5	20	1229
CJTX-C-20/20	1495	1080	60	1474	1431	13	11	954	1100	29.5	1160	1555	1419	611	611	722.5	20	1545
CJTX-C-22/22	1640	1180	60	1625	1582	13	11	1054	1250	47	1240.5	1700	1570	665	705	795.5	20	1591
CJTX-C-25/25	1800	1300	60	1825	1782	13	11	1174	1450	59	1338	1860	1770	775	806	875.5	20	1751
CJTX-C-30/28	2000	1525	60	2134	2091	13	11	1399	1760	56.5	1473	2060	2079	900	941	975.5	20	1951

Supplied on request: Vertical outlet (V) LG-0

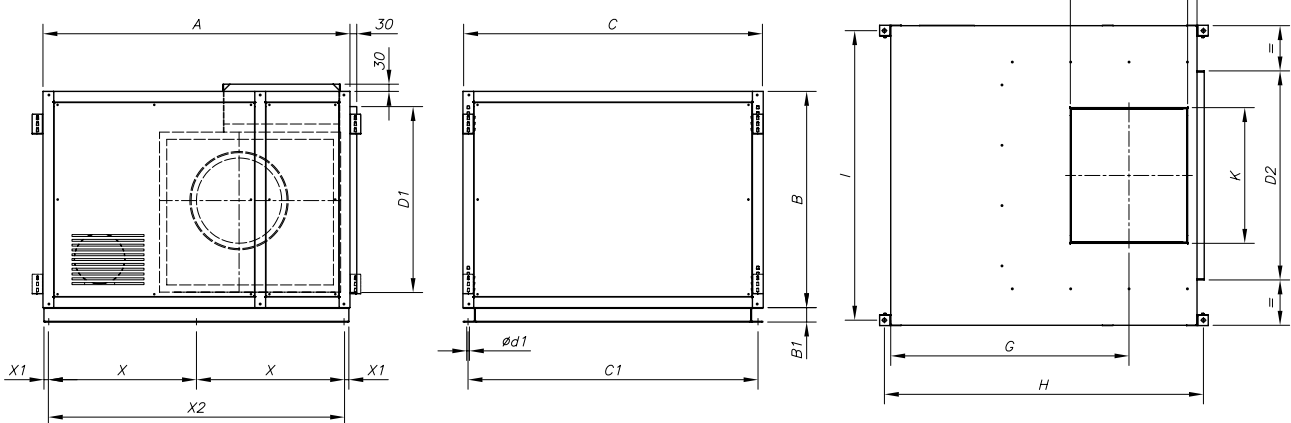

Model	A	B	B1	C	C1	Ød	Ød1	D1	D2	F	G	H	I	K	L	X	X1	X2
CJTX-C-7/7	700	480	-	730	695	10.5	9	354	470	66	306	750	685	239	216	-	-	-
CJTX-C-9/9	785	592	-	759	716	10.5	9	466	490	89	368	835	714	305	270	-	-	-
CJTX-C-10/10	860	618	-	825	782	10.5	9	492	520	86.5	383.5	910	780	334	296	-	-	-
CJTX-C-12/12	970	680	-	945	902	10.5	9	554	620	81.5	423.5	1020	900	395	350	-	-	-
CJTX-C-15/15	1100	776	-	1100	1057	10.5	9	650	720	83.5	457	1150	1055	483	411	-	-	-
CJTX-C-18/18	1278	900	60	1250	1207	10.5	11	774	870	83.5	572.5	1328	1205	565	488	614.5	20	1229
CJTX-C-20/20	1495	1080	60	1474	1431	13	11	954	1100	66	667.5	1555	1419	611	611	722.5	20	1545
CJTX-C-22/22	1640	1180	60	1625	1582	13	11	1054	1250	125.5	702	1700	1570	665	705	795.5	20	1591
CJTX-C-25/25	1800	1300	60	1825	1782	13	11	1174	1450	121	777	1860	1770	775	806	875.5	20	1751
CJTX-C-30/28	2000	1525	60	2134	2091	13	11	1399	1760	115.5	941.5	2060	2079	900	941	975.5	20	1951

Characteristic curves

Q = Airflow in m³/h, m³/s and cfm.

Pe = Static pressure in mm.w.c., Pa and in wg.

CJTX-C-7/7

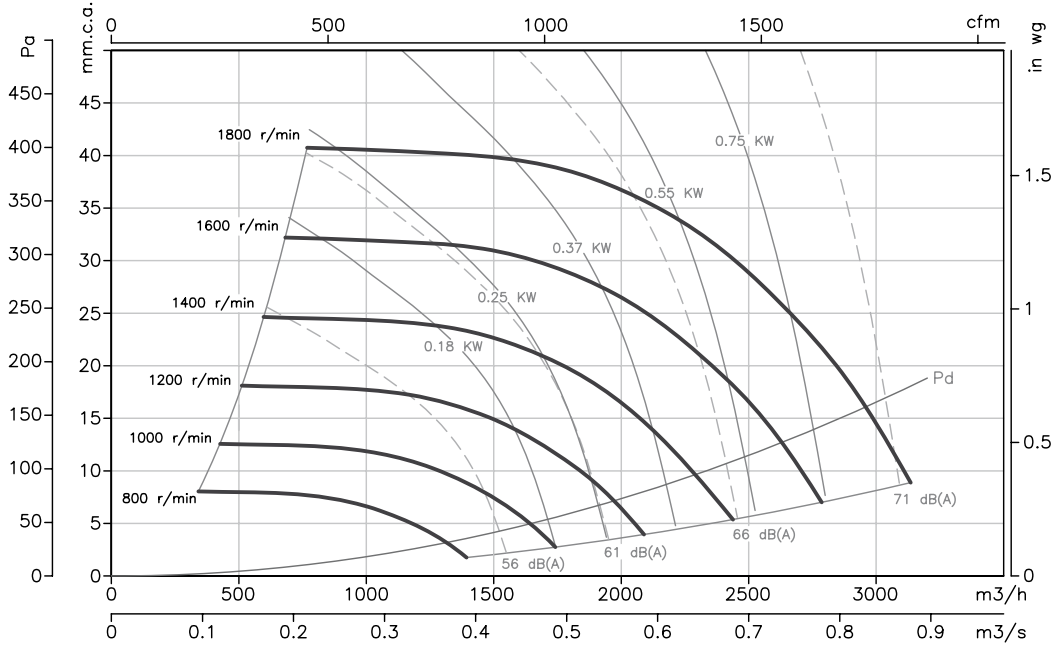

CJTX-C-9/9

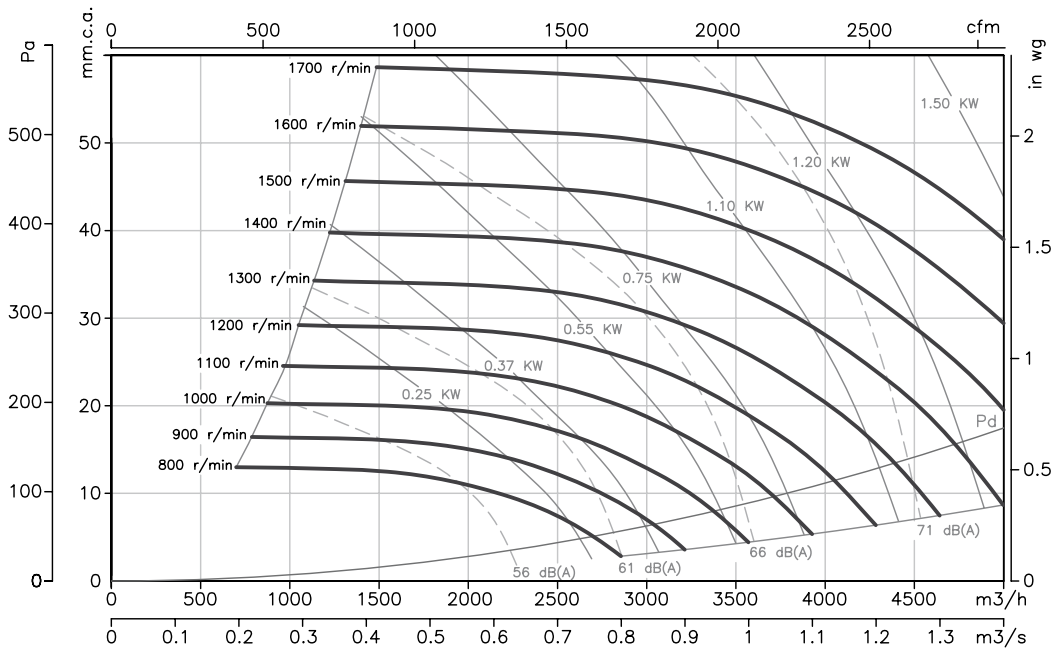

Characteristic curves

Q = Airflow in m³/h, m³/s and cfm.

Pe = Static pressure in mm.w.c., Pa and in wg.

CJTX-C-10/10

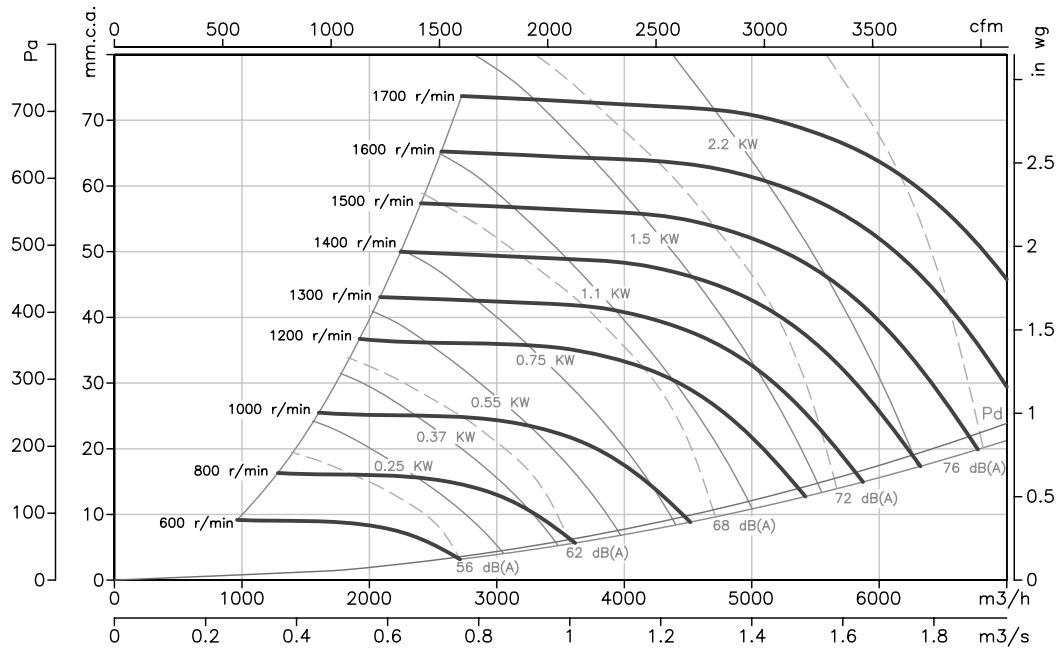

CJTX-C-12/12

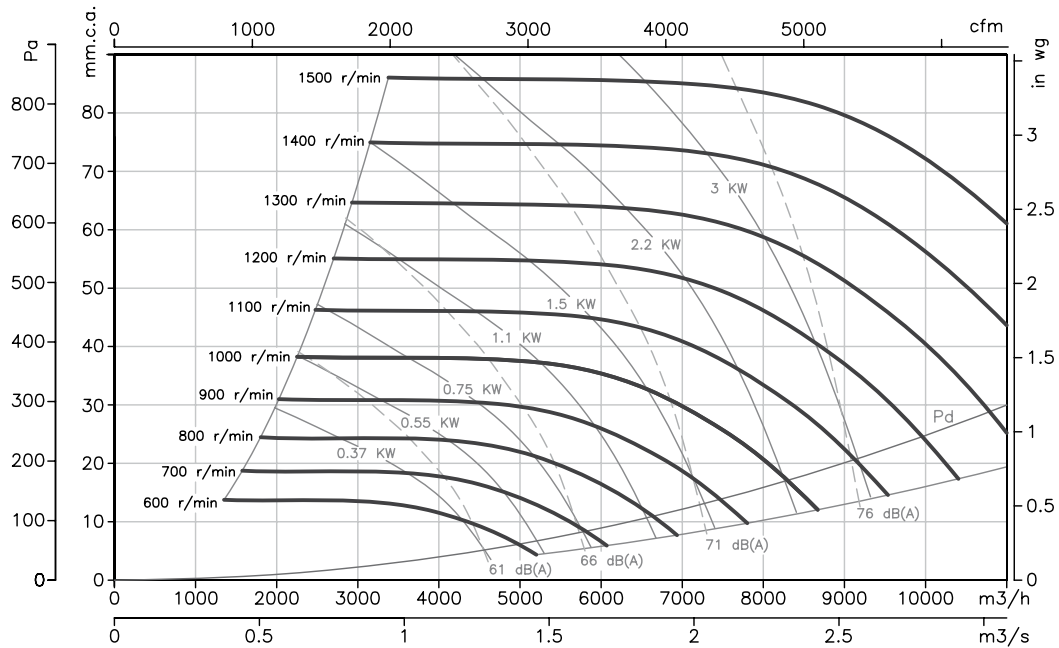

Characteristic curves

Q = Airflow in m³/h, m³/s and cfm.

Pe = Static pressure in mm.w.c., Pa and in wg.

CJTX-C-15/15

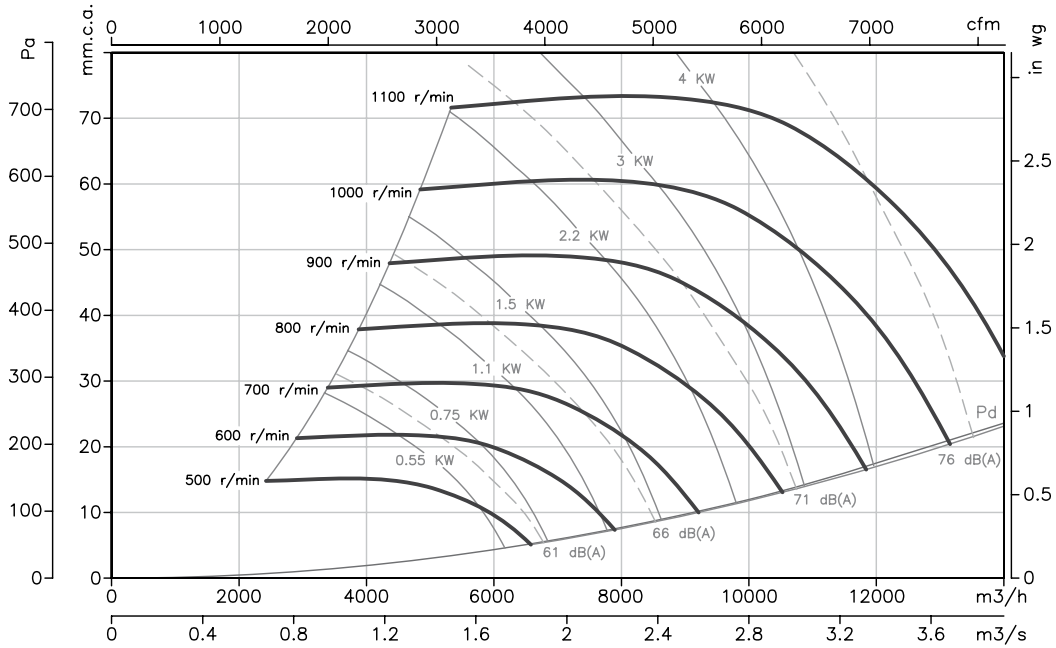

CJTX-C-18/18

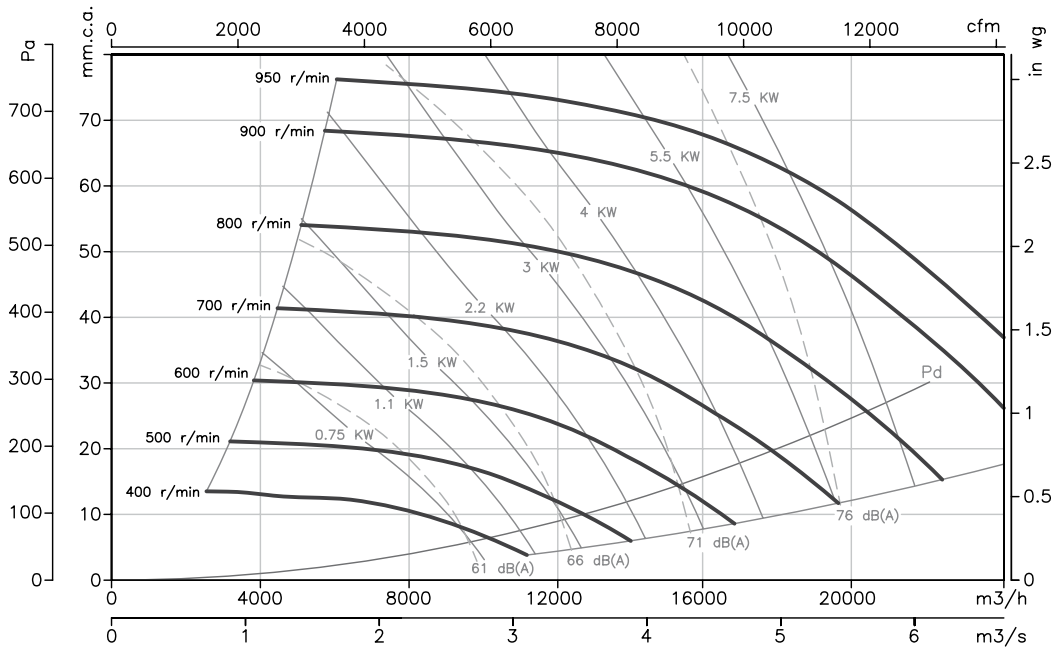

Characteristic curves

Q = Airflow in m³/h, m³/s and cfm.

Pe = Static pressure in mm.w.c., Pa and in wg.

CJTX-C-20/20

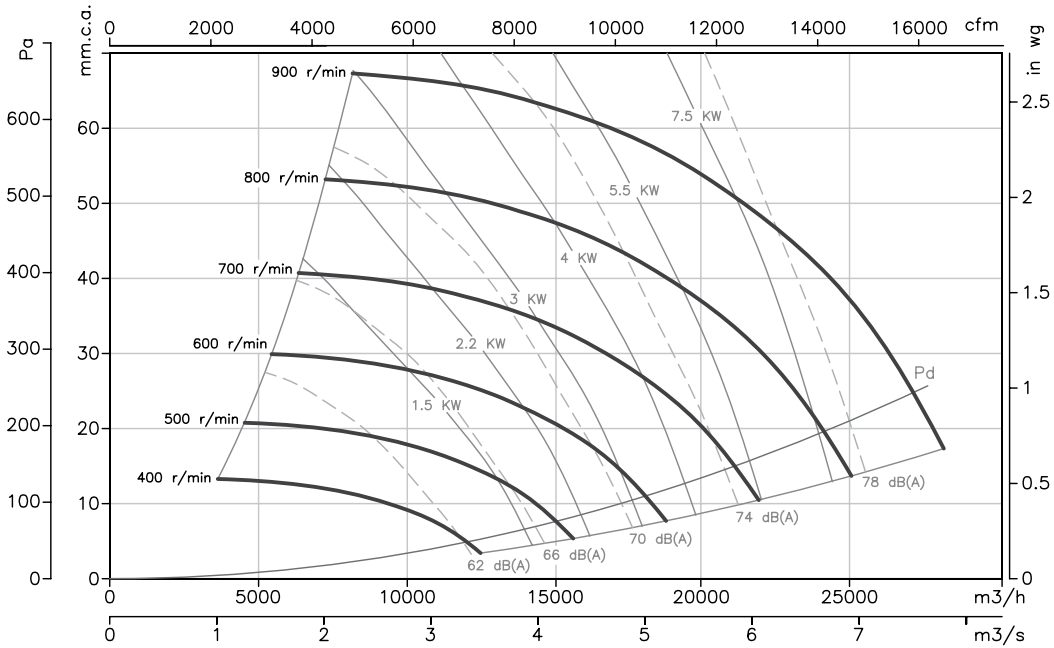

CJTX-C-22/22

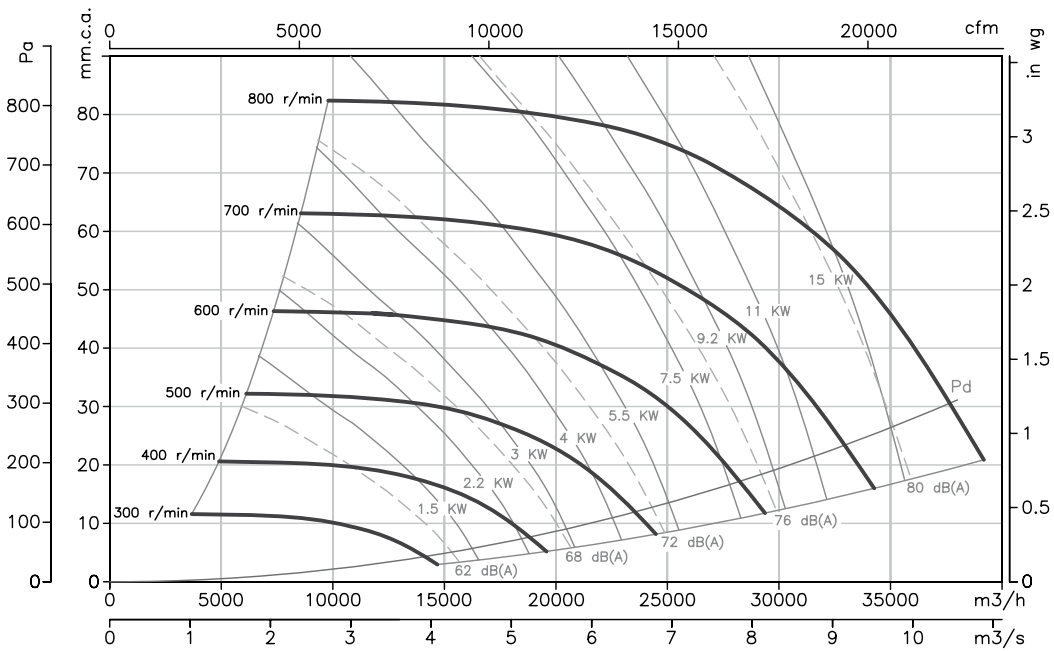

Characteristic curves

Q = Airflow in m³/h, m³/s and cfm.

Pe= Static pressure in mm.w.c., Pa and in wg.

CJTX-C-25/25

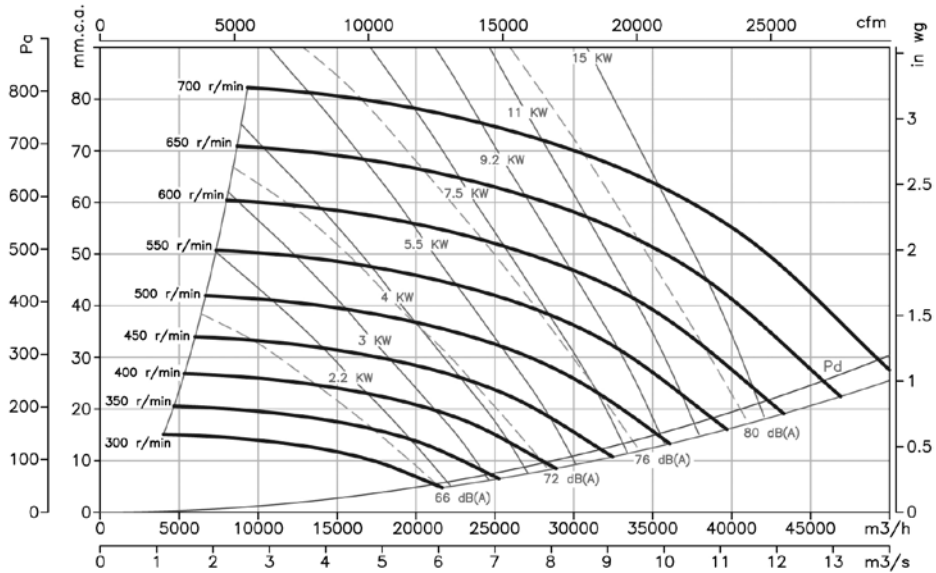

CJTX-C-30/28

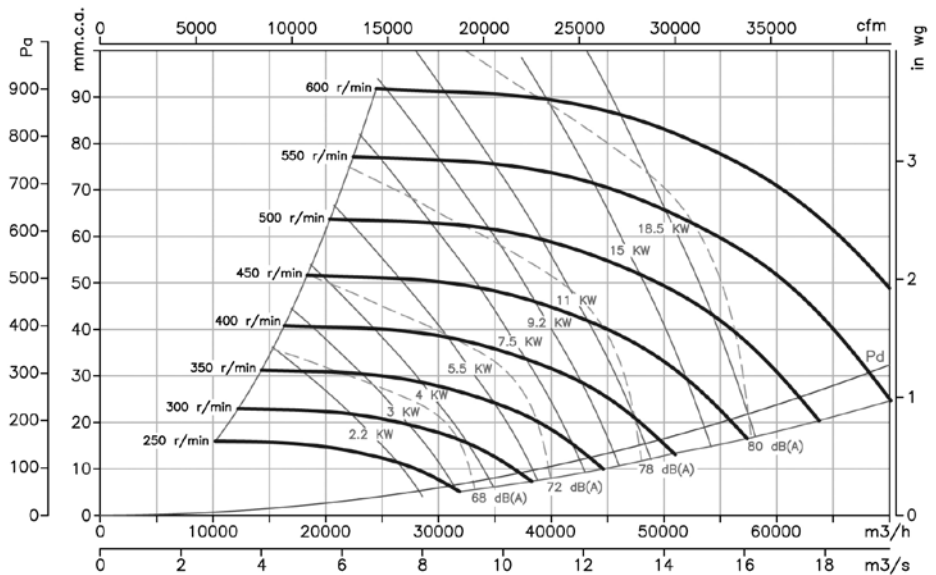

Accessories



CJSX



Motor outside the airflow path

400°C/2h belt-driven extraction units with single-inlet fan

400°C/2h extraction units with motor outside the airflow path to work outside fire danger zones.

Fan:

- Galvanized sheet steel structure.
- Impeller with forward-facing blades made from galvanised sheet steel
- Approval according to Standard EN-12101-3-2002, certification No.: 0370-CPD-0503

Motor:

- Class F motors with ball bearings, IP55 protection
- Three-phase 230/400V.-50Hz. (up to 5.5CV.) and 400/690V.-50Hz. (power over 5.5CV.)
- Max. air temperature to transport: S1 Service -20°C+ 120°C for ongoing use, S2 Service 200°C/2h, 300°C/2h and 400°C/2h

Finish:

- Anticorrosive galvanized sheet steel.

On request:

- Fans with two-speed motor.
- Fans with vertical outlet



Order code

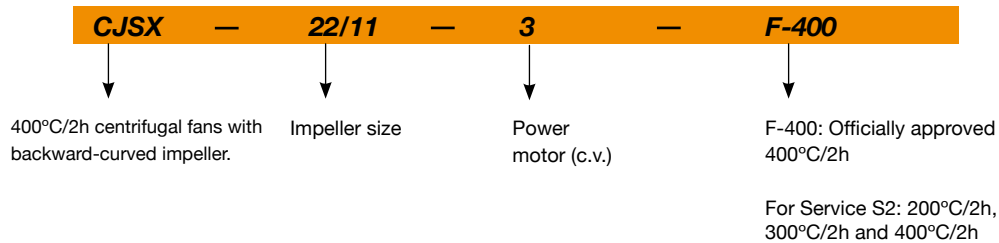

Technical characteristics

Model	Speed (r/min)	Maximum admissible current (A)			Installed Power (kW)	Maximum Airflow (m³/h)	Sound pressure level dB(A)	Approx. weight (Kg)
		230V	400V (A)	690V				
CJSX-12/6-0.75	1000	2.42	1.40		0.55	2600	69	73
CJSX-12/6-1	1100	3.29	1.90		0.75	3100	71	74
CJSX-12/6-1.5	1250	4.49	2.59		1.10	3500	74	77
CJSX-12/6-2	1300	5.98	3.45		1.50	4250	77	80
CJSX-12/6-3	1500	8.31	4.80		2.20	4800	79	85
CJSX-15/7-1	800	3.29	1.90		0.75	4000	67	92
CJSX-15/7-1.5	850	4.49	2.59		1.10	4800	69	95
CJSX-15/7-2	920	5.98	3.45		1.50	5400	72	98
CJSX-15/7-3	1000	8.31	4.80		2.20	6400	75	103
CJSX-15/7-4	1050	11.22	6.48		3.00	7400	77	106
CJSX-18/9-1.5	750	4.49	2.59		1.10	5800	68	111
CJSX-18/9-2	790	5.98	3.45		1.50	6600	70	114
CJSX-18/9-3	800	8.31	4.80		2.20	8200	74	119
CJSX-18/9-4	850	11.22	6.48		3.00	9000	76	122
CJSX-18/9-5.5	920	14.90	8.60		4.00	10500	78	125
CJSX-20/10-2	650	5.98	3.45		1.50	8100	65	203
CJSX-20/10-3	690	8.31	4.80		2.20	10100	68	208
CJSX-20/10-4	750	11.22	6.48		3.00	11500	70	211
CJSX-20/10-5.5	790	14.90	8.60		4.00	13100	73	214

Technical characteristics

Model	Speed (r/min)	Maximum admissible current (A)			Installed Power (kW)	Maximum Airflow (m³/h)	Sound pressure level dB(A)	Approx. weight (Kg)
		230V	400V (A)	690V				
CJSX-20/10-7,5	850		11.10	6.40	5.50	15000	75	227
CJSX-22/11-3	580	8.31	4.80		2.20	11200	67	219
CJSX-22/11-4	610	11.22	6.48		3.00	13000	70	222
CJSX-22/11-5,5	650	14.90	8.60		4.00	15000	72	225
CJSX-22/11-7,5	690		11.10	6.40	5.50	17000	74	238
CJSX-22/11-10	750		14.80	8.50	7.50	19000	76	246
CJSX-22/11-12,5	790		17.80	10.30	9.20	21000	78	257
CJSX-22/11-15	830		21.50	12.40	11.00	22000	79	273
CJSX-22/11-20	910		28.50	16.50	15.00	24500	81	292
CJSX-22/11-25	1000		35.00	20.20	18.50	26000	83	322
CJSX-25/13-4	520	11.22	6.48		3.00	14000	62	254
CJSX-25/13-5,5	550	14.90	8.60		4.00	17000	65	257
CJSX-25/13-7,5	590		11.10	6.40	5.50	19500	67	270
CJSX-25/13-10	620		14.80	8.50	7.50	23000	70	278
CJSX-25/13-12,5	650		17.80	10.30	9.20	25000	72	289
CJSX-25/13-15	690		21.50	12.40	11.00	26500	74	305
CJSX-25/13-20	750		28.50	16.50	15.00	29500	75	324
CJSX-25/13-25	810		35.00	20.20	18.50	32000	77	354
CJSX-30/14-5,5	400	14.90	8.60		4.00	21000	69	331
CJSX-30/14-7,5	425		11.10	6.40	5.50	24000	72	344
CJSX-30/14-10	460		14.80	8.50	7.50	27500	74	352
CJSX-30/14-12,5	480		17.80	10.30	9.20	30000	76	363
CJSX-30/14-15	500		21.50	12.40	11.00	33000	77	379
CJSX-30/14-20	550		28.50	16.50	15.00	36500	78	398
CJSX-30/14-25	600		35.00	20.20	18.50	38000	81	428

Dimensions in mm

Standard supply horizontal outlet (H) RD-90

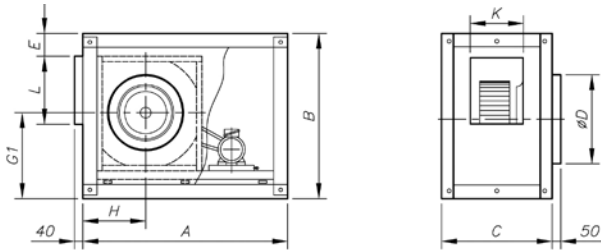

Supply on demand vertical outlet (V) RD-0

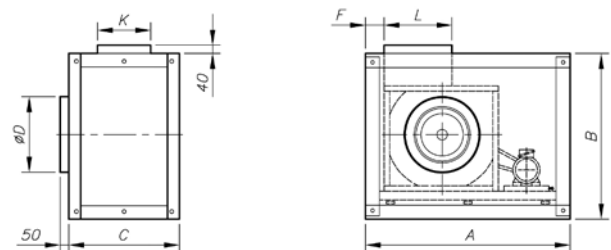

Supply on demand horizontal outlet (H) LG-90

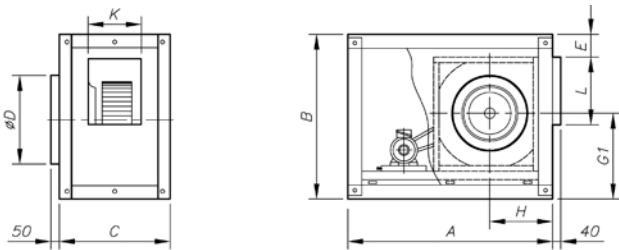

Supply on demand vertical outlet (V) LG-0

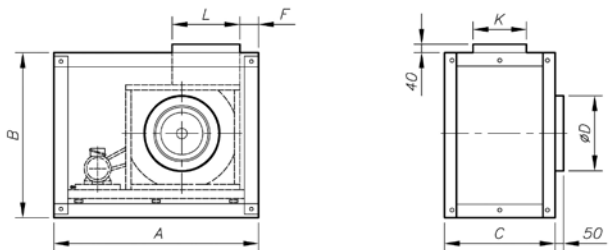

Model	A	B	C	ØD	E	with bedplate E	F	G1	with bedplate G1	H	L	with bedplate L	K
CJSX-12/6-H	850	650	540	330	74	-	-	288	-	288	346	-	210
CJSX-12/6-V	850	650	540	330	-	-	30	318	-	328	346	-	210
CJSX-15/7-H	1000	755	600	400	74	-	-	328	-	328	411	-	270
CJSX-15/7-V	1000	755	600	400	-	-	30	378	-	383	411	-	270
CJSX-18/9-H	1200	875	620	480	74	-	-	383	-	388	491	-	305
CJSX-18/9-V	1200	875	620	480	-	-	30	433	-	448	491	-	305
CJSX-20/10-H	1485	1175	730	565	175	120	-	475	530	440	613	605	343
CJSX-20/10-V	1485	1175	730	565	-	-	75	535	-	585	613	-	343
CJSX-22/11-H	1570	1250	760	615	165	110	-	510	565	470	708	700	373
CJSX-22/11-V	1570	1250	760	615	-	-	75	570	-	640	708	-	373
CJSX-25/13-H	1610	1375	820	685	175	120	-	550	605	495	803	795	423
CJSX-25/13-V	1610	1375	820	685	-	-	75	625	-	705	803	-	423
CJSX-30/14-H	1845	1600	855	820	160	95	-	655	710	580	943	935	488
CJSX-30/14-V	1845	1600	855	820	-	-	75	760	-	825	943	-	488

Characteristic curves

Q = Airflow in m³/h, m³/s and cfm.

Pe= Static pressure in mm.w.c., Pa and in wg.

CJSX 12/6

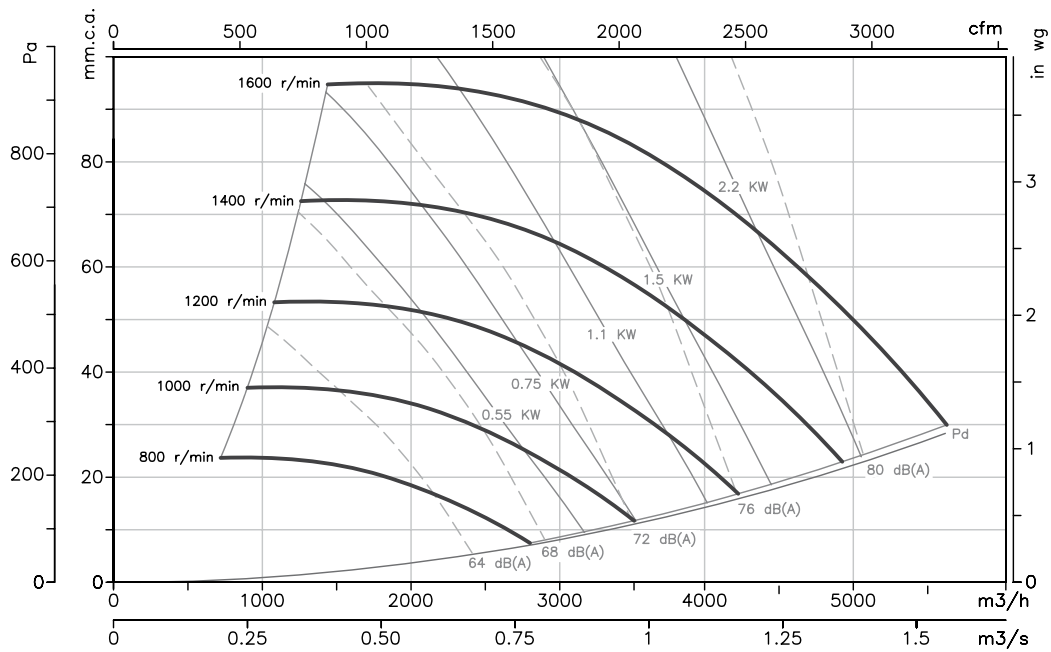

CJSX 15/7

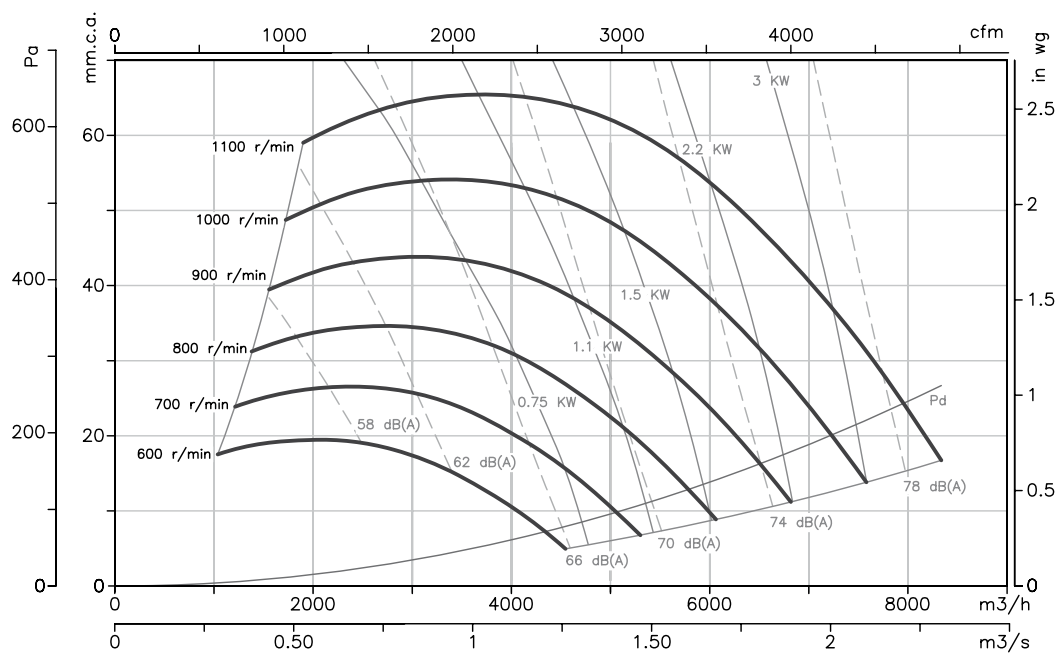

Characteristic curves

Q = Airflow in m³/h, m³/s and cfm.

Pe= Static pressure in mm.w.c., Pa and in wg.

CJSX 18/9

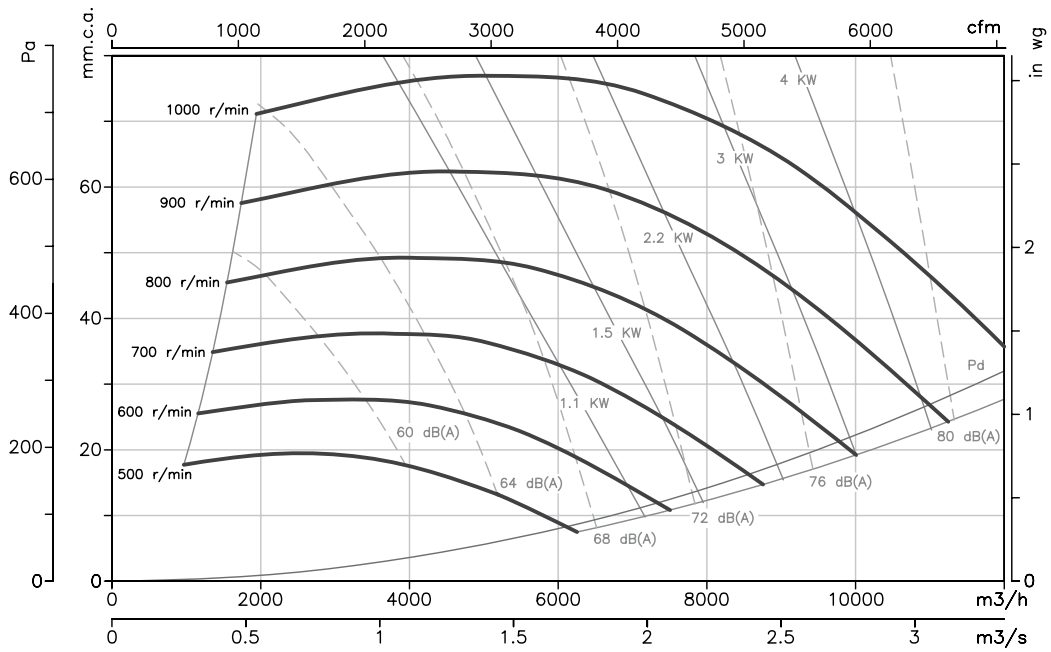

CJSX 20/10

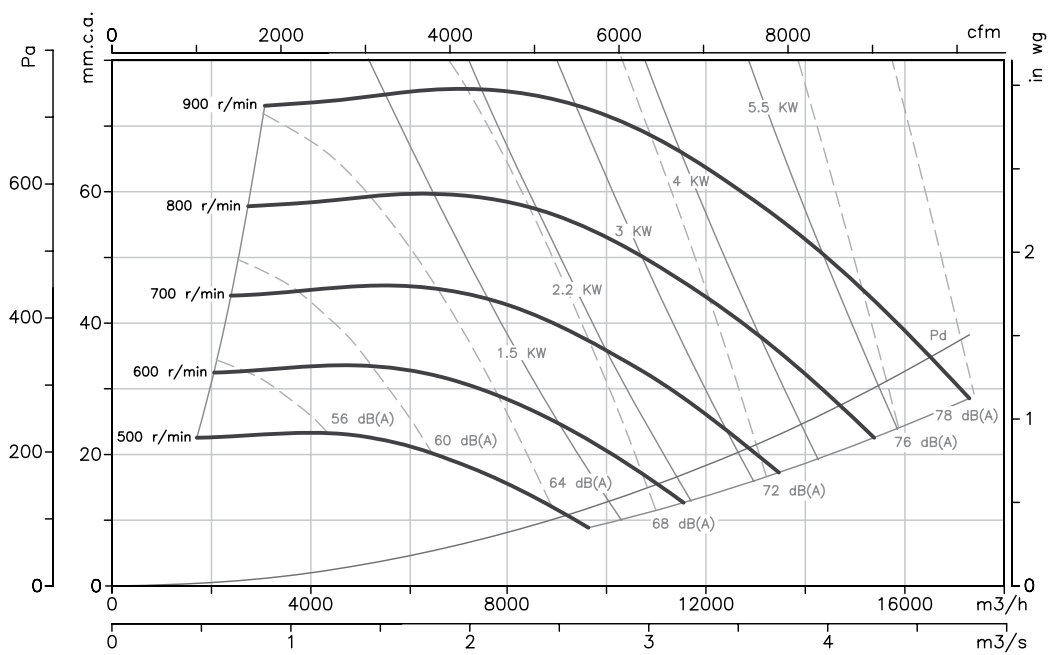

Characteristic curves

Q = Airflow in m³/h, m³/s and cfm.

Pe= Static pressure in mm.w.c., Pa and in wg.

CJSX 22/11

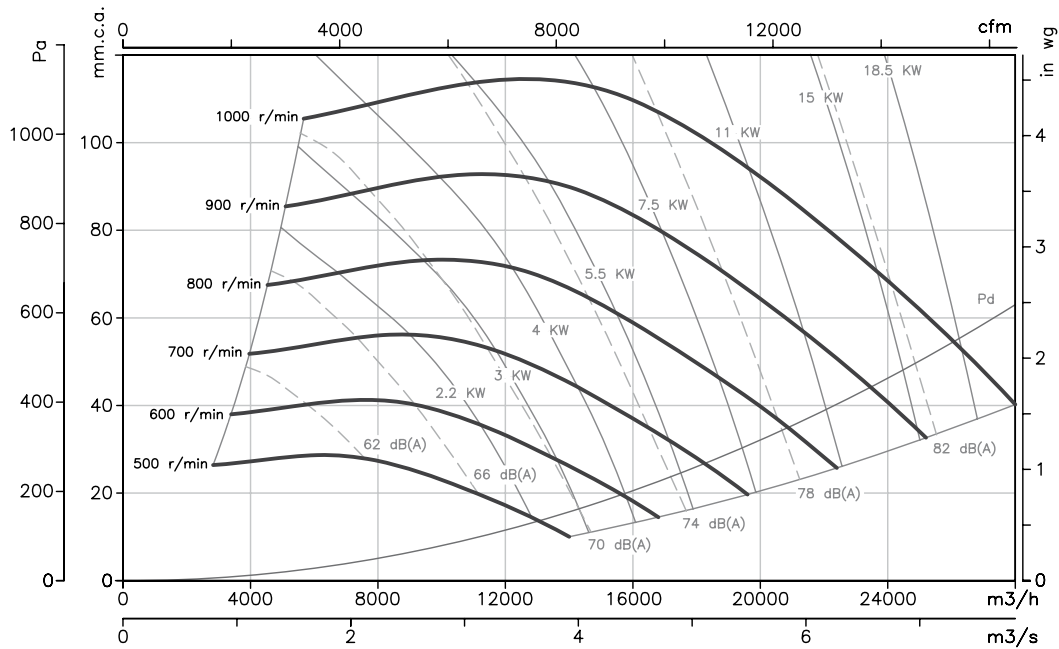

CJSX 25/13

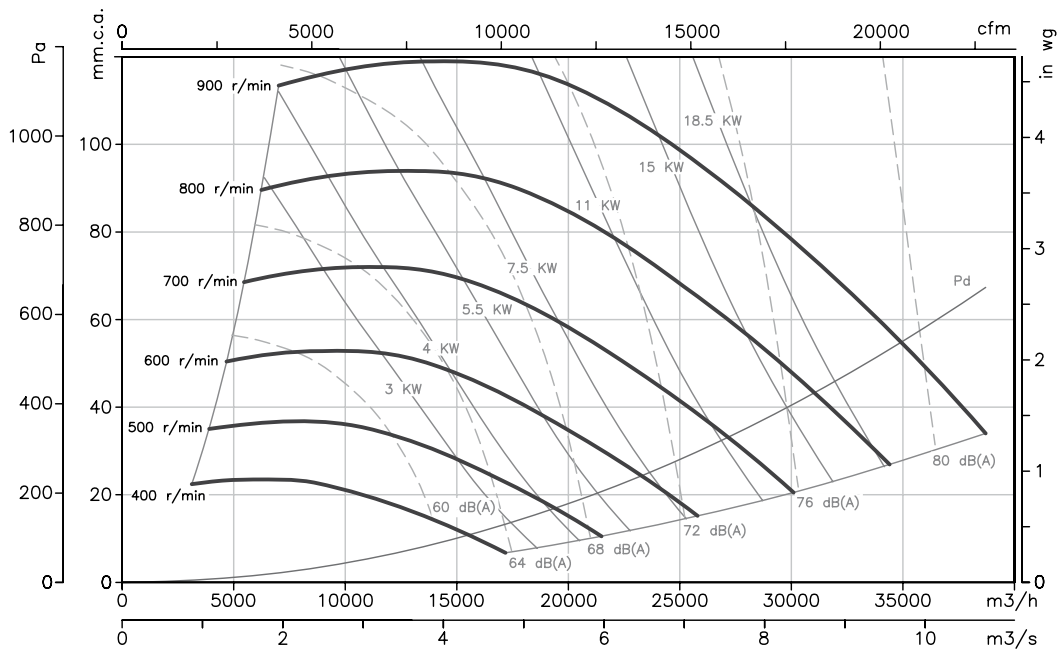

Characteristic curves

Q = Airflow in m³/h, m³/s and cfm.

Pe= Static pressure in mm.w.c., Pa and in wg.

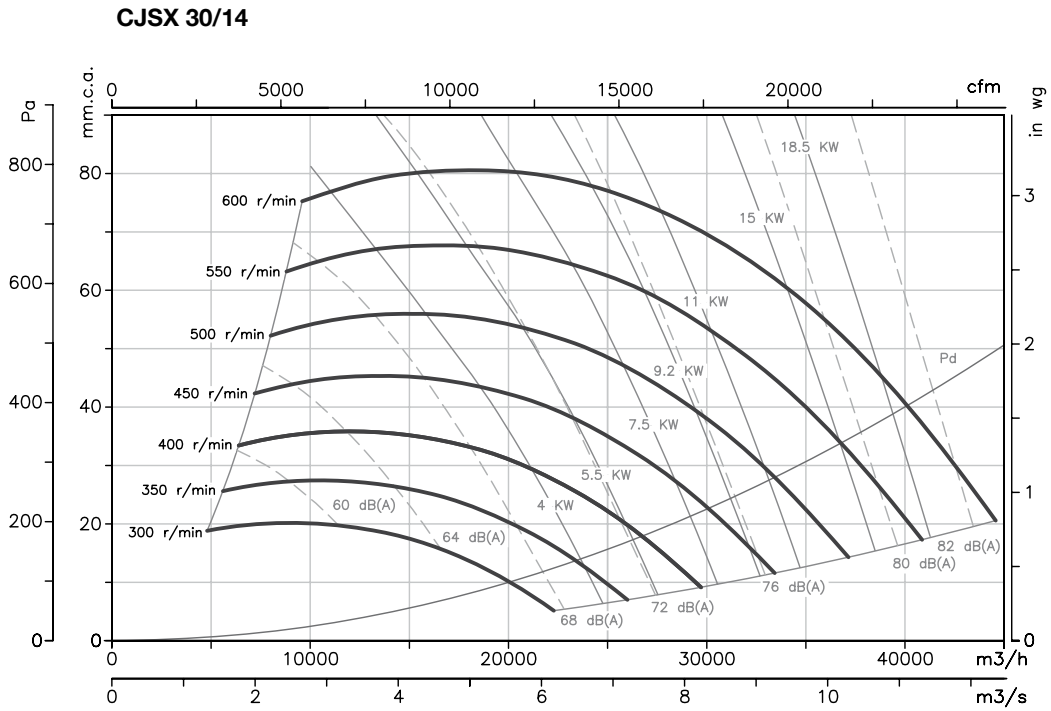

Accessories



CSX CJSRX



CSX



CJSRX

400°C/2h belt-driven centrifugal fans and extraction units to work outside fire danger zones with backward-curved impeller

CSX: 400°C/2h belt-driven centrifugal fans with backward-curved impeller.

CJSRX: 400°C/2h belt-driven extraction units with backward-curved impeller.

Fan:

- Steel sheet casing
- Impeller with backward-curved blades made from sheet steel
- Approval according to Standard EN-12101-3:2002, certificate no.: 0370-CPD-
- Protective anti-contact guard

Motor:

- Class F motors with ball bearings, IP55 protection
- Three-phase 230/400V.-50Hz. (up to 5.5CV.) and 400/690V.-50Hz. (power over 5.5CV.)
- Max. air temperature to transport: S1 Service -20°C to + 150°C for ongoing use, S2 Service 200°C/2h, 300°C/2h and 400°C/2h

Finish:

- Anticorrosive galvanized sheet steel.

On request:

- Special windings for different voltages
- Fan designed to transport air up to 250°C
- ATEX certification, Category 2
- Fans with two-speed motor.



High-performance and robust backward-curved impeller.



Order code

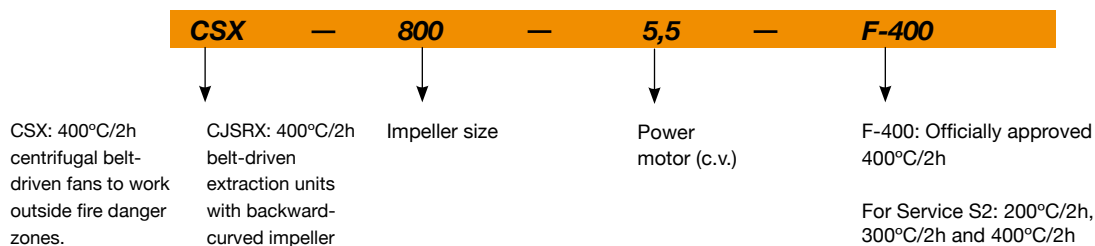

Technical characteristics

Model	Speed (r/min)	Maximum admissible current (A)			Installed Power (kW)	Maximum Airflow (m³/h)	Approx. weight (Kg)
		230V	400V (A)	690V			
CSX CJSRX 315-0,75	2520	2.35	1.35	-	0.55	4000	32
CSX CJSRX 315-1	2800	3.13	1.80	-	0.75	4500	34
CSX CJSRX 315-1,5	3250	4.35	2.50	-	1.10	5050	36
CSX CJSRX 315-2	3550	5.83	3.35	-	1.50	5650	39
CSX CJSRX 315-3	4000	7.60	4.37	-	2.20	6400	42
CSX CJSRX 355-0,75	2100	2.43	1.40	-	0.55	4750	41
CSX CJSRX 355-1	2300	3.13	1.80	-	0.75	5200	44

Technical characteristics

Model			Speed (r/min)	Maximum admissible current (A)			Installed Power (kW)	Maximum Airflow (m³/h)	Approx. weight (Kg)
				230V	400V (A)	690V			
CSX	CJSRX	355-1,5	2600	4.35	2.50	-	1.10	6000	46
CSX	CJSRX	355-2	2875	5.83	3.35	-	1.50	6650	48
CSX	CJSRX	355-3	3350	7.60	4.37	-	2.20	7500	53
CSX	CJSRX	355-4	3600	10.35	5.95	-	3.00	8200	57
CSX	CJSRX	400-0,75	1730	2.35	1.35	-	0.55	5600	49
CSX	CJSRX	400-1	1900	3.30	1.90	-	0.75	6100	52
CSX	CJSRX	400-1,5	2180	4.50	2.59	-	1.10	7000	54
CSX	CJSRX	400-2	2400	5.83	3.35	-	1.50	7700	56
CSX	CJSRX	400-3	2750	7.60	4.37	-	2.20	8800	59
CSX	CJSRX	400-4	3050	10.35	5.95	-	3.00	9800	64
CSX	CJSRX	400-5,5	3300	13.22	7.60	-	4.00	10500	72
CSX	CJSRX	450-0,75	1230	2.43	1.40	-	0.55	5800	61
CSX	CJSRX	450-1	1380	3.30	1.90	-	0.75	6500	64
CSX	CJSRX	450-1,5	1550	4.50	2.59	-	1.10	7500	66
CSX	CJSRX	450-2	1700	6.00	3.45	-	1.50	8050	68
CSX	CJSRX	450-3	1950	8.35	4.80	-	2.20	9050	72
CSX	CJSRX	450-4	2200	10.35	5.95	-	3.00	10100	76
CSX	CJSRX	450-5,5	2400	13.22	7.60	-	4.00	11500	85
CSX	CJSRX	450-7,5	2600	-	10.50	6.09	5.50	12500	95
CSX	CJSRX	450-10	2980	-	13.90	8.06	7.50	14000	100
CSX	CJSRX	450-12,5	3150	-	16.80	9.74	9.20	15000	108
CSX	CJSRX	500-1,5	1250	4.50	2.59	-	1.10	8200	88
CSX	CJSRX	500-2	1380	6.00	3.45	-	1.50	9000	90
CSX	CJSRX	500-3	1560	8.35	4.80	-	2.20	10200	93
CSX	CJSRX	500-4	1730	11.27	6.48	-	3.00	11500	98
CSX	CJSRX	500-5,5	1900	13.91	8.00	-	4.00	12500	107
CSX	CJSRX	500-7,5	2130	-	11.10	6.43	5.50	14000	116
CSX	CJSRX	500-10	2300	-	13.90	8.06	7.50	15500	121
CSX	CJSRX	500-12,5	2500	-	16.80	9.74	9.20	16500	130
CSX	CJSRX	500-15	2600	-	20.50	11.88	11.00	17500	156
CSX	CJSRX	560-2	1200	6.00	3.45	-	1.50	11000	100
CSX	CJSRX	560-3	1380	8.35	4.80	-	2.20	12200	103
CSX	CJSRX	560-4	1500	11.27	6.48	-	3.00	14000	108
CSX	CJSRX	560-5,5	1670	13.91	8.00	-	4.00	15500	117
CSX	CJSRX	560-7,5	1850	-	11.10	6.43	5.50	16200	122
CSX	CJSRX	560-10	2050	-	14.80	8.58	7.50	18300	132
CSX	CJSRX	560-12,5	2200	-	16.80	9.74	9.20	20000	141
CSX	CJSRX	560-15	2300	-	20.50	11.88	11.00	21000	166
CSX	CJSRX	630-3	1060	8.35	4.80	-	2.20	13200	119
CSX	CJSRX	630-4	1150	11.27	6.48	-	3.00	14400	123
CSX	CJSRX	630-5,5	1300	13.91	8.00	-	4.00	16000	132
CSX	CJSRX	630-7,5	1450	-	11.10	6.43	5.50	18000	138
CSX	CJSRX	630-10	1600	-	14.80	8.58	7.50	19800	147
CSX	CJSRX	630-12,5	1700	-	17.50	10.14	9.20	21600	156
CSX	CJSRX	630-15	1820	-	22.00	12.75	11.00	23040	181
CSX	CJSRX	630-20	1890	-	29.00	16.81	15.00	25200	202
CSX	CJSRX	710-4	1000	11.27	6.48	-	3.00	17280	186
CSX	CJSRX	710-5,5	1100	13.91	8.00	-	4.00	19080	195
CSX	CJSRX	710-7,5	1200	-	11.10	6.43	5.50	20880	200
CSX	CJSRX	710-10	1350	-	14.80	8.58	7.50	23760	210
CSX	CJSRX	710-12,5	1480	-	17.50	10.14	9.20	25920	219
CSX	CJSRX	710-15	1550	-	22.00	12.75	11.00	27720	244
CSX	CJSRX	710-20	1680	-	29.00	16.81	15.00	29880	265
CSX	CJSRX	710-25	1790	-	36.50	21.16	18.50	32100	285
CSX		800-4	800	11.27	6.48	-	3.00	20800	226
CSX		800-5,5	880	13.91	8.00	-	4.00	22680	234
CSX		800-7,5	970	-	11.10	6.43	5.50	25100	240
CSX		800-10	1070	-	14.80	8.58	7.50	27720	250
CSX		800-12,5	1150	-	17.50	10.14	9.20	30000	259
CSX		800-15	1230	-	22.00	12.75	11.00	32040	284
CSX		800-20	1350	-	29.00	16.81	15.00	34000	305
CSX		800-25	1450	-	36.50	21.16	18.50	37800	325
CSX		800-30	1540	-	42.00	24.35	22.00	40000	344
CSX		900-4	650	11.27	6.48	-	3.00	23760	281
CSX		900-5,5	720	13.91	8.00	-	4.00	26000	289
CSX		900-7,5	790	-	11.10	6.43	5.50	29500	295

Technical characteristics

Model	Speed (r/min)	Maximum admissible current (A)			Installed Power (kW)	Maximum Airflow (m³/h)	Approx. weight (Kg)
		230V	400V (A)	690V			
CSX 900-10	860	-	14.80	8.58	7.50	32100	305
CSX 900-12,5	940	-	17.50	10.14	9.20	34200	314
CSX 900-15	1020	-	22.00	12.75	11.00	37900	339
CSX 900-20	1120	-	29.00	16.81	15.00	42000	360
CSX 900-25	1190	-	36.50	21.16	18.50	43500	380
CSX 900-30	1250	-	42.00	24.35	22.00	45500	399
CSX 900-40	1400	-	59.00	34.20	30.00	51000	453
CSX 1000-5,5	600	13.91	8.00	-	4.00	30500	342
CSX 1000-7,5	660	-	11.10	6.43	5.50	33000	348
CSX 1000-10	730	-	14.80	8.58	7.50	37000	358
CSX 1000-12,5	790	-	17.50	10.14	9.20	40000	366
CSX 1000-15	840	-	22.00	12.75	11.00	42500	392
CSX 1000-20	940	-	29.00	16.81	15.00	46000	413
CSX 1000-25	1000	-	36.50	21.16	18.50	50000	432
CSX 1000-30	1060	-	42.00	24.35	22.00	52500	452
CSX 1000-40	1160	-	59.00	34.20	30.00	59000	506
CSX 1000-50	1260	-	68.00	39.42	37.00	64000	549

Dimensions in mm

RD 90 standard supply

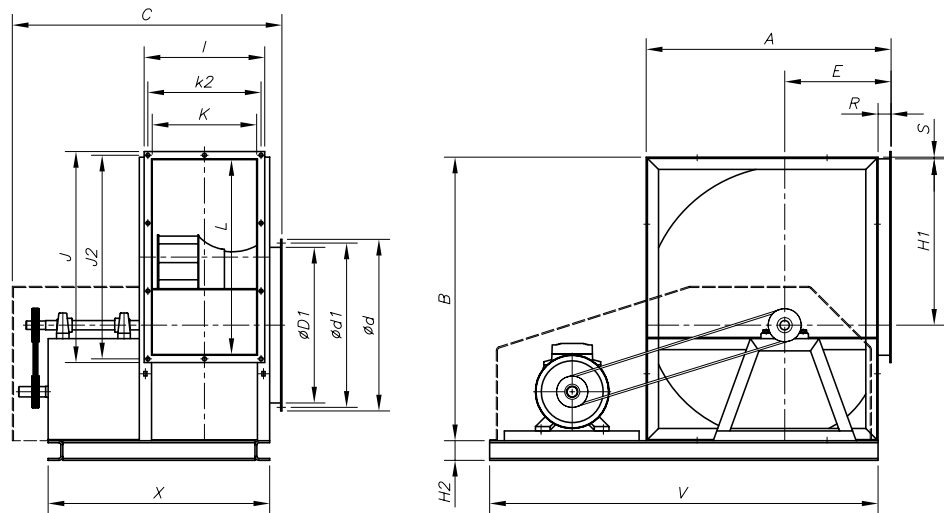

Model	A	B	C	ød	ød1	øD1	E	H1	H2	I
CSX -315	518	578	700	383	344	322	236	340	80	259
CSX -355	578	655	775	423	386	362	261	383	80	286
CSX -400	661	736	800	466	432	404	2902	431.5	80	316
CSX -450	726	827	895	515	485	448	322	486	80	344
CSX -500	800	918	930	570	544	510	352	538	80	376
CSX -560	893	1030	1020	635	605	570	390	603	80	414
CSX -630	999	1157	1065	700	670	635	434	678.5	80	460
CSX -710	1121	1303	1185	778	750	722	485	765	80	512
CSX -800	1250	1468	1245	875	844	808	535	862	80	567
CSX -900	1408	1648	1375	980	845	896	604	971	80	613
CSX -1000	1541	1810	1450	1080	1044	996	657	1066	80	694

Model	J	J2	K	k2	L	R	S	V	X
CSX -315	460	434	223	233	404	38	3	920	556
CSX -355	509	483	247	260	453	30	6	980	627
CSX -400	563	537	274	290	507	38	4.5	1100	654
CSX -450	526	599	308	318	569	45	5	1200	728
CSX -500	694	668	344	350	638	50	5	1280	764
CSX -560	771	745	383	366	715	48	8	1400	855
CSX -630	867	831	432	434	801	53	7	1550	904
CSX -710	964	928	478	483	898	63	7	1700	1005
CSX -800	1063	1039	533	541	1007	69	7	1880	1060
CSX -900	1186	1160	595	602	1130	89	7	2050	1191
CSX -1000	1323	1297	663	668	1267	79	9	2250	1259

Dimensions in mm

Standard supply
horizontal outlet (H) RD 90

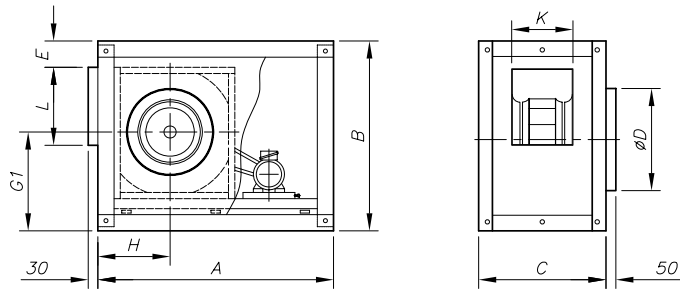

On request
horizontal outlet (H) LG 90

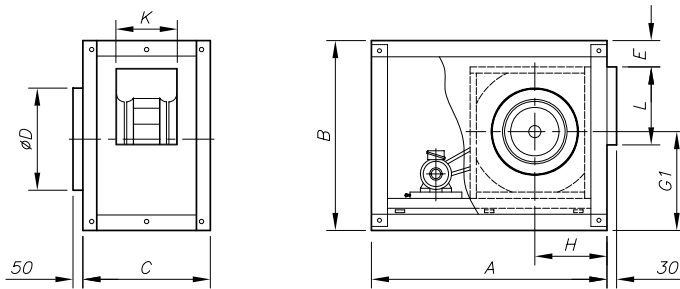

On request
vertical outlet (V) LG 0

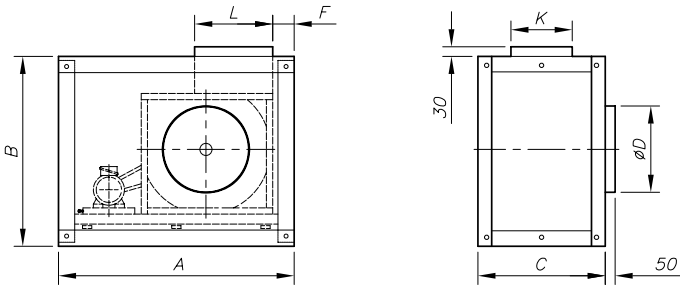

On request
vertical outlet (V) RD 0

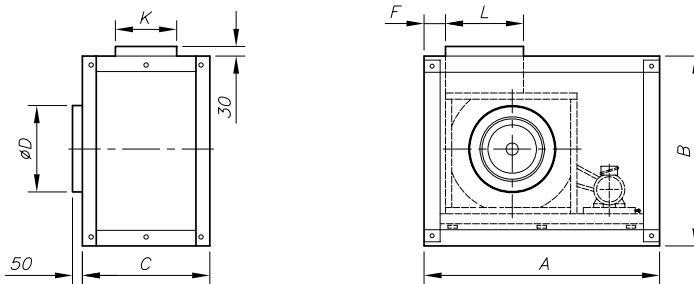

Model	A	B	C	ØD	E	F	G1	H	L	K
CJSRX-315-H	850	695	540	325	55.5	-	298	271	412	230
CJSRX-315-V	895	650	540	325	-	41	345	385	412	230
CJSRX-355-H	1000	788	600	365	72	-	329	312.5	461.5	256
CJSRX-355-V	1035	755	600	365	-	34	378	380	461.5	256
CJSRX-400-H	1200	875	620	405	76.5	-	363	341.5	515.5	282
CJSRX-400-V	1200	875	620	405	-	33	424	469	515.5	282
CJSRX-450-H	1250	975	670	450	86	-	396	373.5	577.5	316
CJSRX-450-V	1300	925	670	450	-	35	467	524	577.5	316
CJSRX-500-H	1300	1175	734	515	195	-	438	397	646.5	352
CJSRX-500-V	1401	995	734	515	-	44	510.5	584	646.5	352
CJSRX-560-H	1400	1250	766	575	141.5	-	502.5	435	723	392
CJSRX-560-V	1500	1080	766	575	-	39	585.5	643.5	723	392
CJSRX-630-H	1500	1380	823	640	143.5	-	55	479	809	440
CJSRX-630-V	1700	1220	823	640	-	64	647.5	745.5	809	440
CJSRX-710-H	1750	1600	857	730	217	-	613.5	530	907	486
CJSRX-710-V	1850	1390	857	730	-	26	718.5	794	907	486

Characteristic curves

Q = Airflow in m³/h, m³/s and cfm.

Pe = Static pressure in mm.w.c., Pa and in wg.

CSX CJSRX 315

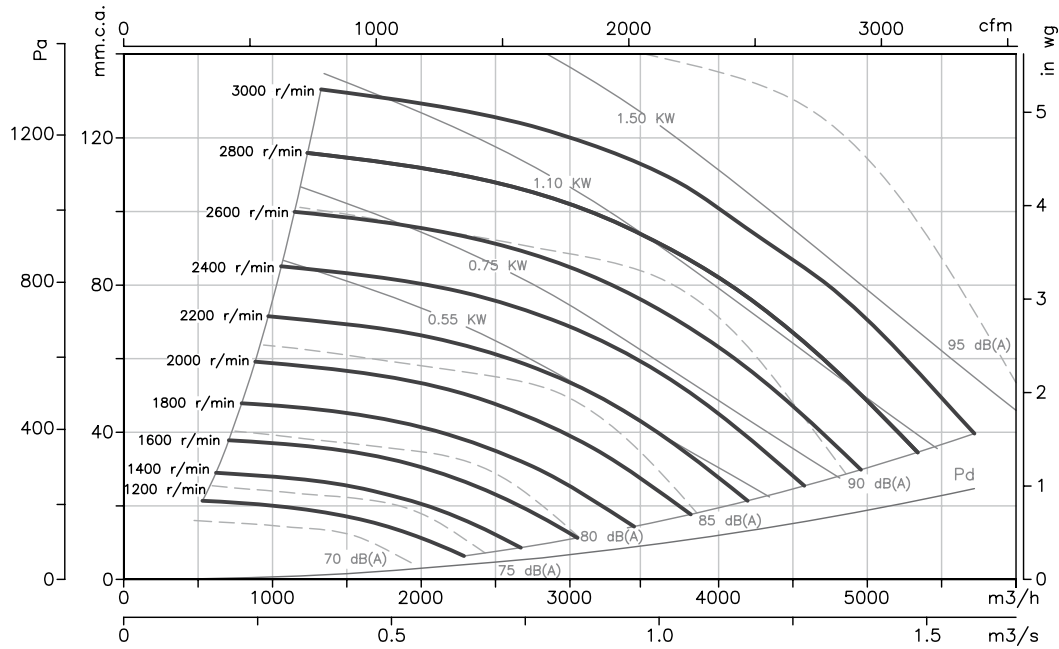

CSX CJSRX 355

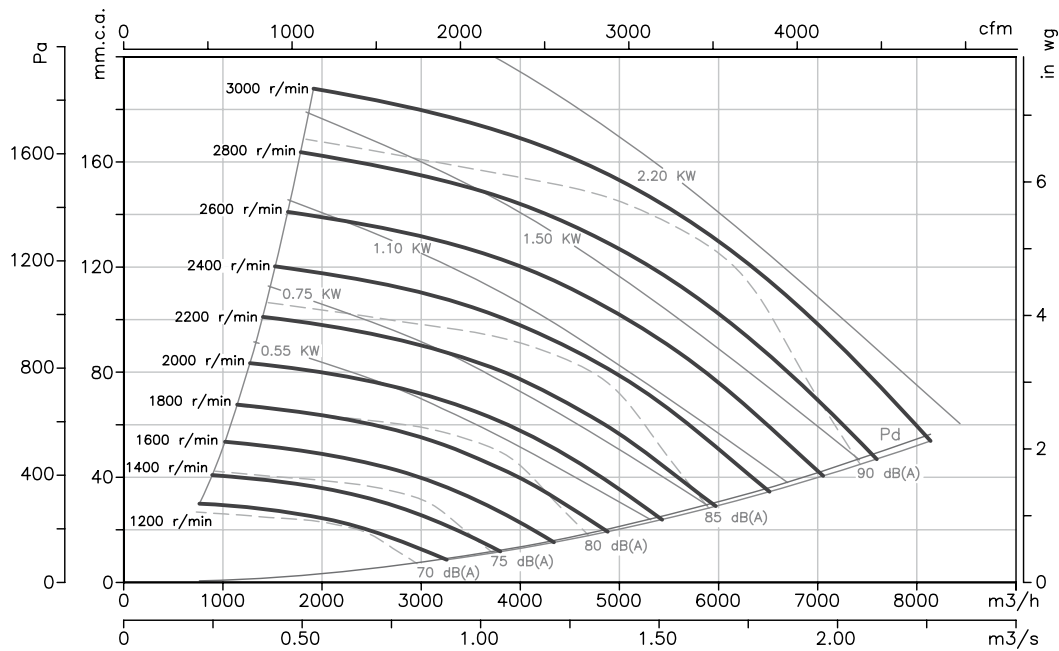

Characteristic curves

Q = Airflow in m³/h, m³/s and cfm.

Pe= Static pressure in mm.w.c., Pa and in wg.

CSX CJSRX 400

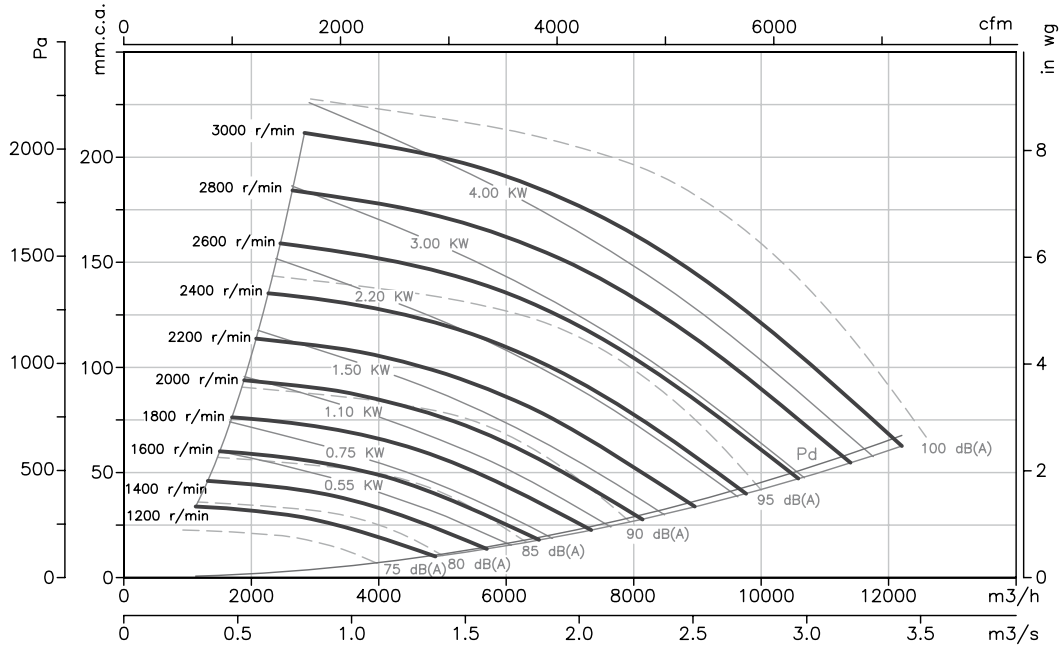

CSX CJSRX 450

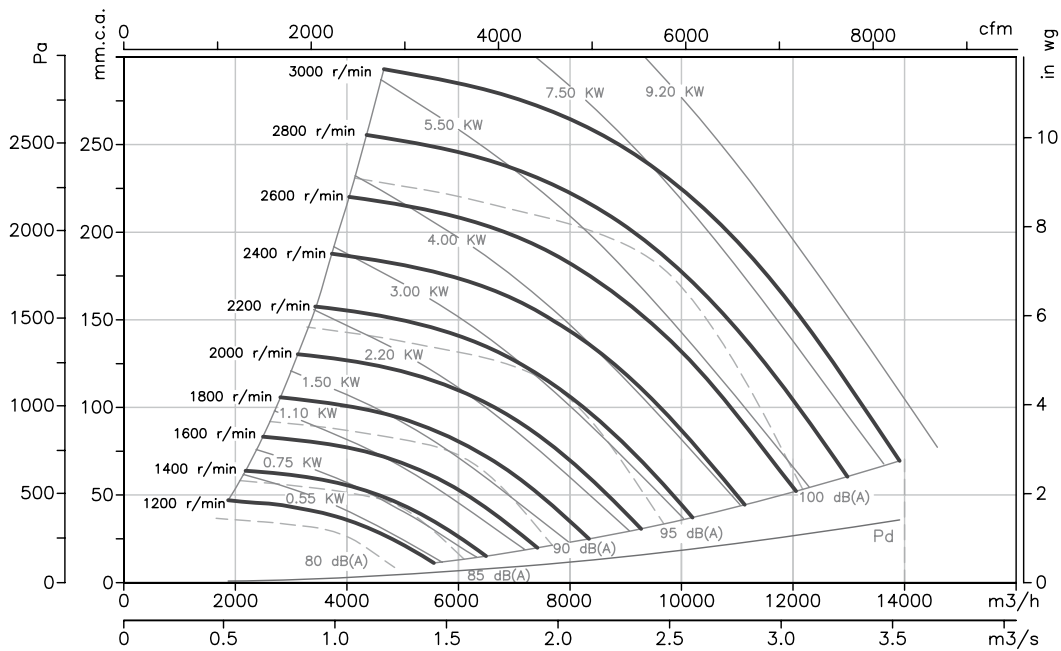

Characteristic curves

Q = Airflow in m³/h, m³/s and cfm.

Pe = Static pressure in mm.w.c., Pa and in wg.

CSX CJSRX 500

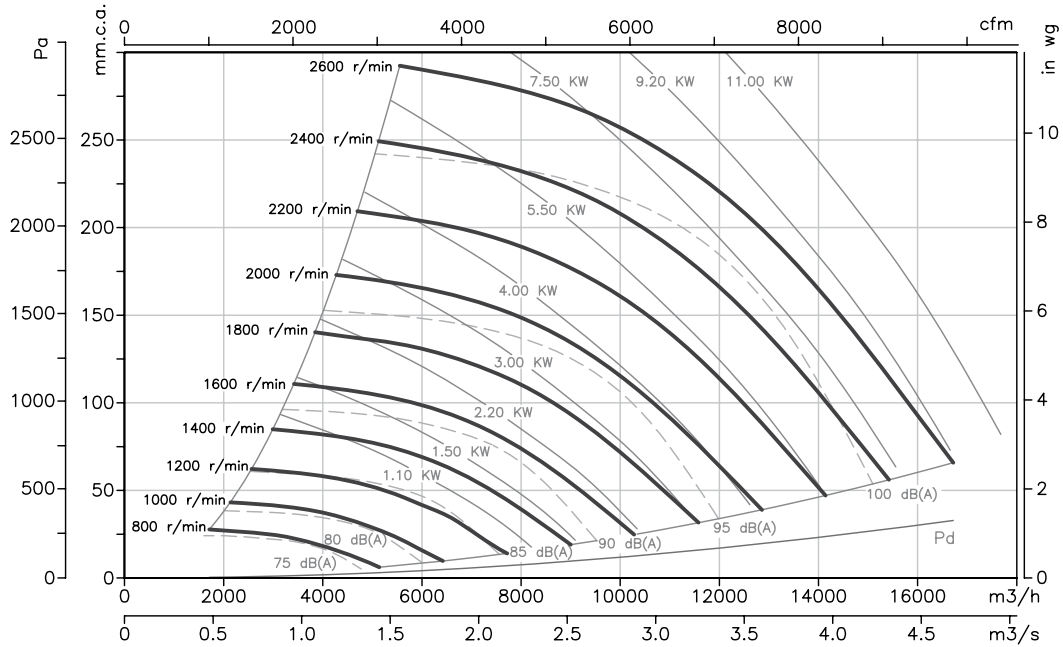

CSX CJSRX 560

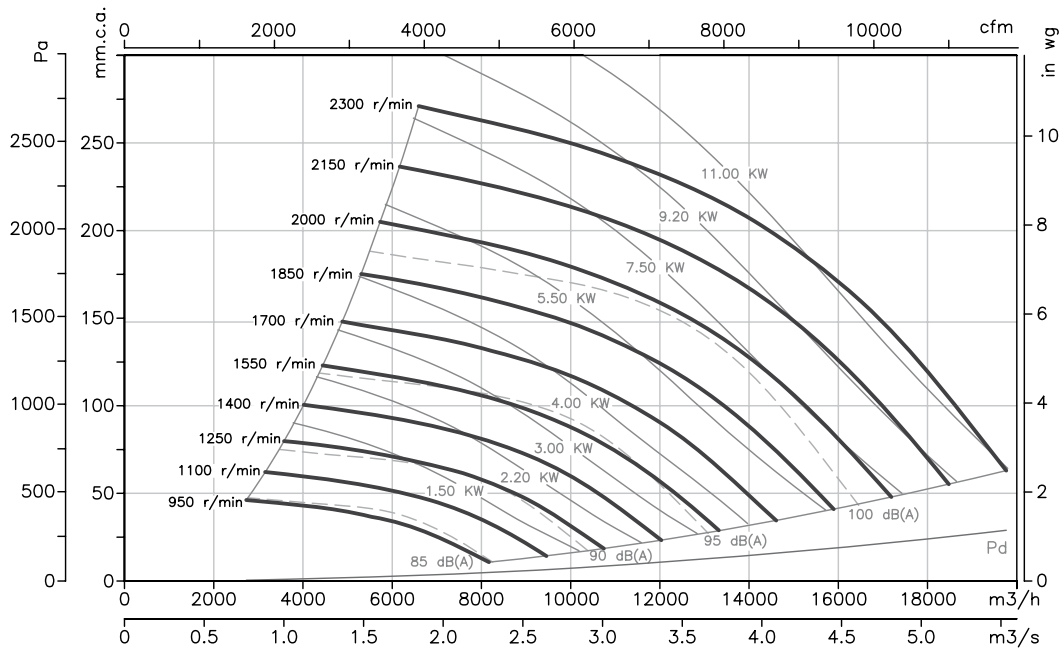

Characteristic curves

Q = Airflow in m³/h, m³/s and cfm.

Pe= Static pressure in mm.w.c., Pa and in wg.

CSX CJSRX 630

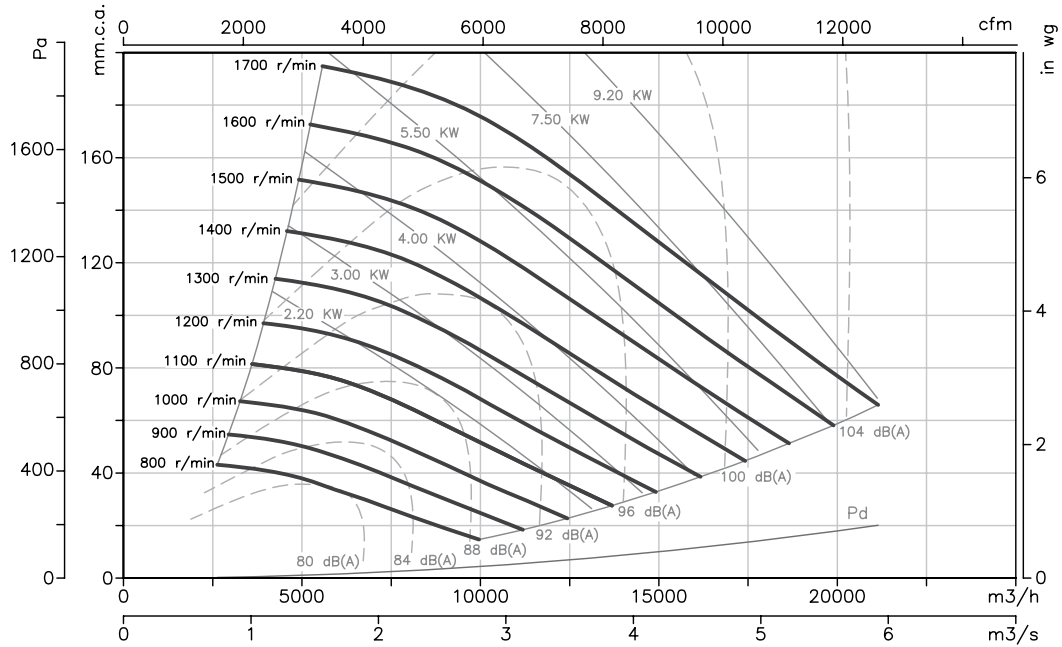

CSX CJSRX 710

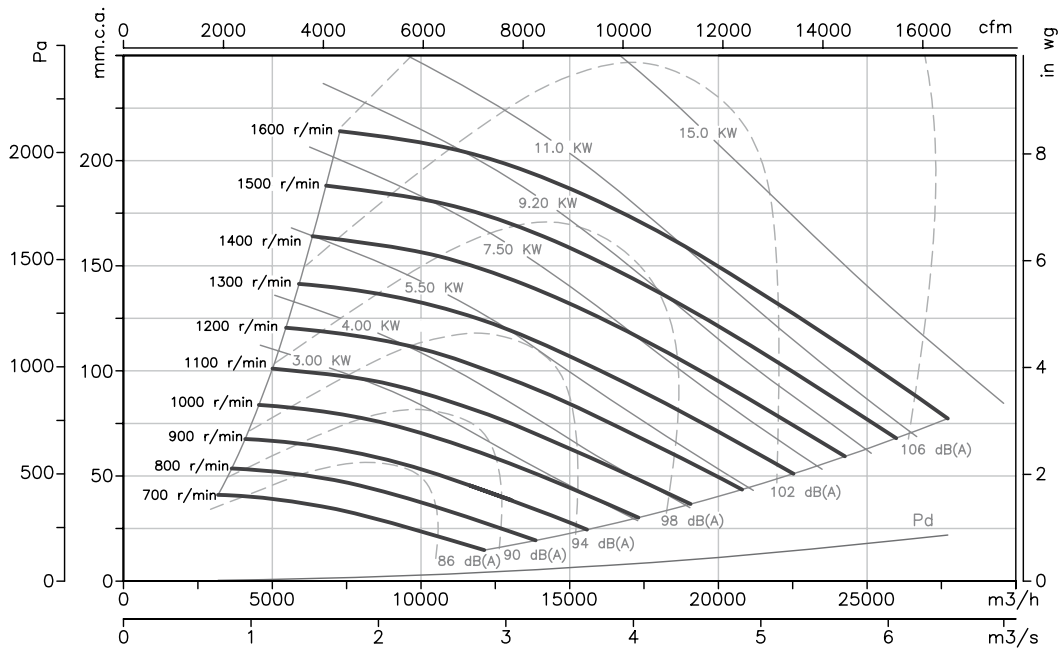

Characteristic curves

Q = Airflow in m³/h, m³/s and cfm.

Pe = Static pressure in mm.w.c., Pa and in wg.

CSX 800

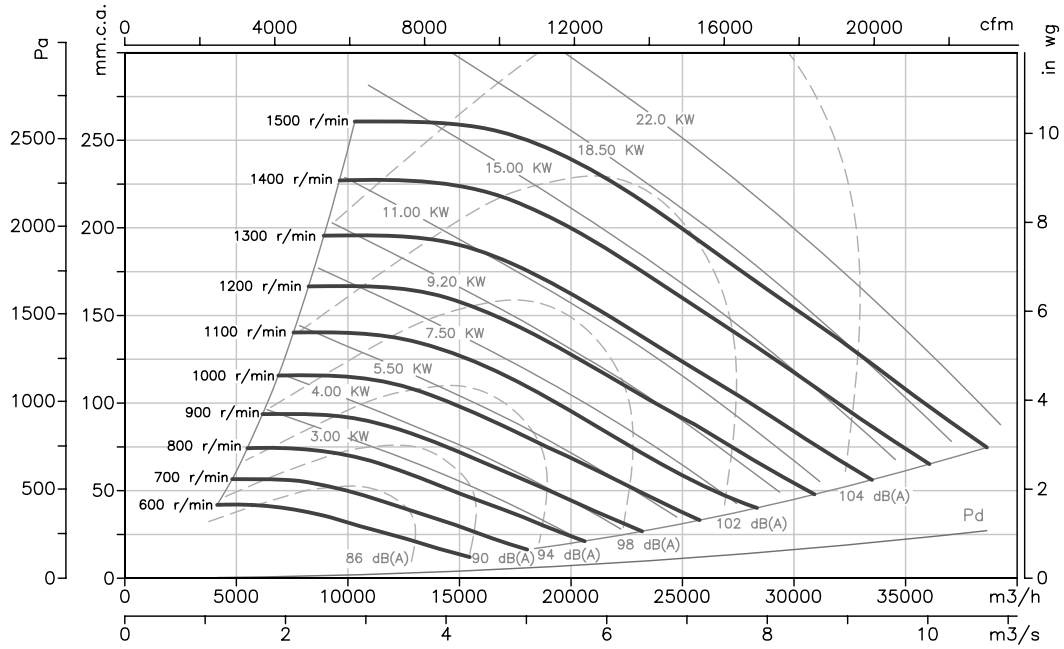

CSX 900

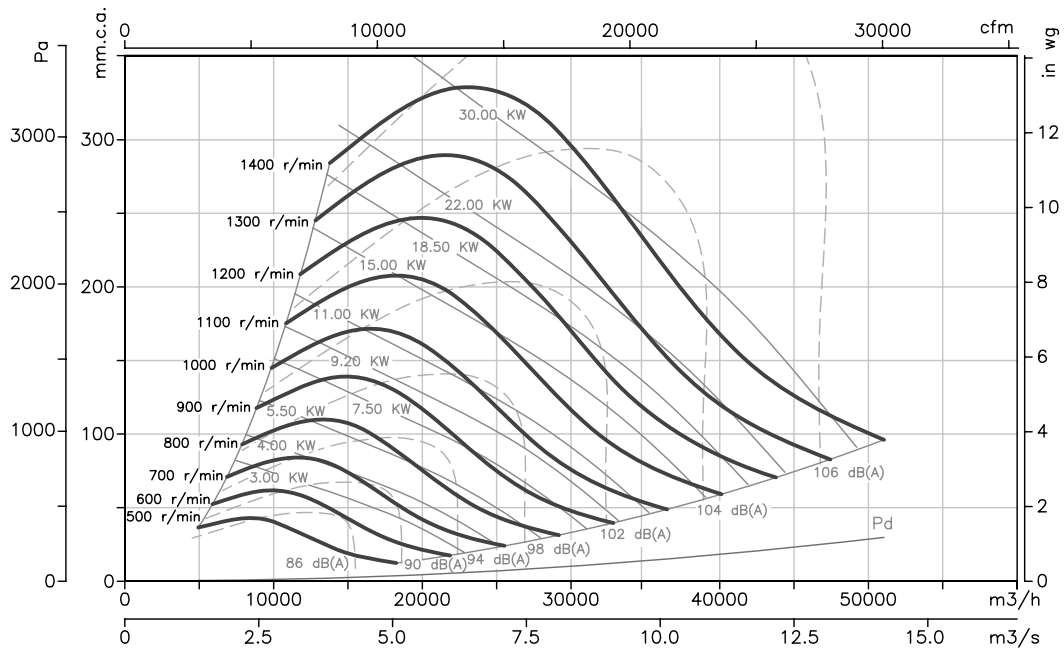

Characteristic curves

Q = Airflow in m³/h, m³/s and cfm.

Pe= Static pressure in mm.w.c., Pa and in wg.

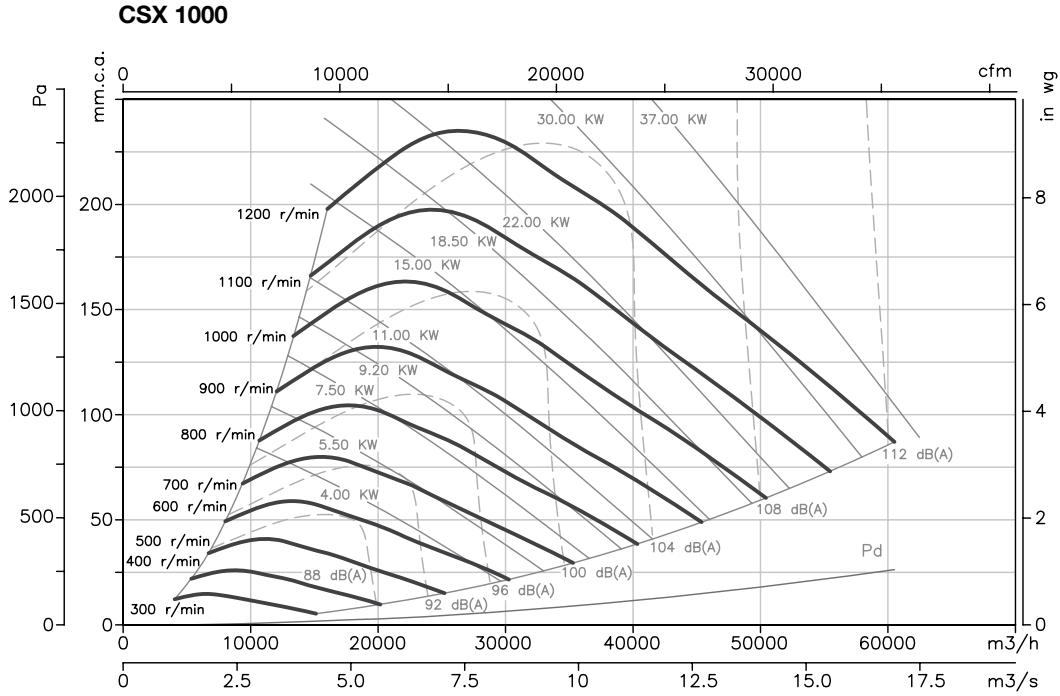

Accessories



Alphabetical index of references

CBD	8
CBDT	68
CBX	21
CBXC	21
CBXR	21
CBXT	21
CDXR	48
CDXRT	48
CJBC	15
CJBC/ECO	15
CJBD	13
CJBD/AL	13
CJBDT	68
CJBX	31
CJBX/AL	31
CJDXR	48
CJSRX	87
CJSX	81
CJSXR	56
CJTSA	40
CJTX-C	72
CSX	87
CSXR	56
CSXRT	56
TSA	40
TSAT	40
TWIN	19

OUR PRODUCTS

In-line duct fans



Axial fans



Centrifugal fans



Fans for smoke extraction
400°C/2h - 300°C/1h



ATEX Fans for explosive atmospheres



Roof fans



Ventilation systems
for houses

NEW



Heat recovery units

NEW



Filtration units

NEW



Air curtains

NEW



Efficient Energy Applications



Ask us for
information

Ventilation software.
General catalogue



Crta. de Berga, km 0.7
 E-08580 SANT QUIRZE DE BESORA
 (Barcelona - Spain)
 Tel. +34 93 852 91 11
 Fax +34 93 852 90 42
 comercial@sodeca.com
 Export sales: ventilation@sodeca.com
 www.sodeca.com



Export Sales

SODECA EXPORT
 Crta. de Berga, km 0.7
 E-08580 SANT QUIRZE DE BESORA
 Barcelona - SPAIN
 Tel. +34 93 852 91 11
 Fax +34 93 852 90 42
 ventilation@sodeca.com

PORTUGAL
 Mr. Albert Bartés
 E-08580 SANT QUIRZE DE BESORA
 Barcelona - SPAIN
 Tel. +34 93 852 91 11
 Fax +34 93 852 90 42
 comercial@sodeca.com

SODECA SOUTH AMERICA
 Sodeca Ventiladores Ltda
 Mr. Juan Susacasa
 Avda. Puerta Sur 03380
 San Bernardo, SANTIAGO, CHILE
 Tel. 0056 9 6 835 8131
 jsusacasa@sodeca.com

SODECA CARIBBEAN AREA
 Mr. Carlos A. Hernández Gil
 Residencial Miramar N° 120B-7ma
 Ave. N° 1805 entre 18 y 20.
 Miramar Playa, CIUDAD DE LA HABANA, CUBA
 Tel. 00537 20 43721
 sodeca@enet.cu



Crta. de Berga, km 0.7
E-08580 SANT QUIRZE DE BESORA
(Barcelona - Spain)
Tel. +34 93 852 91 11
Fax +34 93 852 90 42
comercial@sodeca.com
Export sales: ventilation@sodeca.com

www.sodeca.com

