

CENTRIFUGAL FANS



CBD



CMR



CAS

IN-LINE DUCT EXTRACTORS



SV



NEOLINEO



CL

CENTRIFUGAL FANS AND IN-LINE DUCT EXTRACTORS

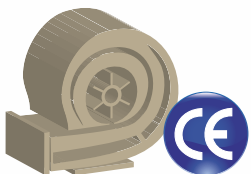

According
EU Regulation





OUR COMMITMENT TO THE ENVIRONMENT

Sodeca has begun a new stage of study and design of new trends in ventilation which will help to preserve the environment and to make the energy saving which so much concerns today's society.



To obtain an **improvement in energy efficiency** of fans and of ventilation facilities, the engineering department of Sodeca has **balanced the energy consumption of the fans** with their maximum performance, in the habitual areas of work. This has required a restructuring of the curves and their presentation in this and future Sodeca catalogues.

SODECA has concentrated its activity on the production of industrial fans, ventilation systems and extractors for the removal of smoke in case of fire since 1983, when it was founded.

SODECA's fans and extractors are present in all European countries and in many parts of the world, thanks to the quality of the product and the methods of research and development used.

Our quality procedures used and certified by BUREAU VERITAS, in accordance with ISO 9001:2008, are another of the reasons which make **SODECA** one of the best and most renowned fan manufacturers in Europe.

Without a doubt, the most important factor to achieve our objectives is the human factor, the great professionals who work at your service, offering not only ventilation equipment but also solutions to any ventilation need required by our customers.

We sincerely offer you the possibility of visiting our facilities in Sant Quirze de Besora, with over 16,000 square metres of built area, where you will be able to see our fan manufacture with perfect clarity and with the highest standards of quality, complying with the ISO and AMCA standards.

This catalogue is only a small part of our possibilities. Do not hesitate to contact us. We will put all our experience and our human resources at your disposal.



*installations
headquarters of
SODECA s.a.,
at Sant Quirze
de Besora and
manufacturing plant
in Santiago
de Chile.*



CENTRIFUGAL FANS AND IN-LINE EXTRACTORS

Sodeca has specialised since its inception in the design and manufacture of fans and accessories for industrial applications.

The union of the experience acquired over decades of work with fans together with the technology supplied by engineers in different departments has made it possible for Sodeca to become one of the largest manufacturers of industrial ventilation in the world.

The industrial applications require a great capacity for adaptation to the specifications of each project and flexibility in manufacture, so as to fulfil the real needs of each client.

In order to fulfil this objective, Sodeca has a line of Standard products and a line of products with special manufacture, for the construction of fans adapted to the demands of our clients.

For years constant investments have been made in the development of internal processes and applications to achieve the manufacture and supply of special industrial fans, with an extremely limited design and manufacturing period.

Teamwork of our engineering department, together with universities and technology centres as well as close collaboration between the design departments of our external collaborators makes it possible to achieve innovative solutions of industrial ventilation in a short period of time.

Throughout our history, we have developed all kinds of technology in fans for industrial applications which are currently used all over the world. It is our objective to continue to invest in this sector so as to continue to be one of the most esteemed manufacturers of industrial fans in the world.



IN-LINE DUCT FANS

<p>SV SV/PLUS SV/ECO</p>  <p>In-line duct fans</p> <p>12</p>	<p>CJBC CJBC/ECO</p>  <p>Exhaust fans and compact extraction units for direct operation</p> <p>18</p>		
<p>NEOLINEO</p>  <p>In-line duct fans with Long Life ball bearings</p> <p>22</p>	<p>CA/LINE</p>  <p>In-line duct fans with Long Life ball bearings</p> <p>26</p>	<p>CL CL/PLUS</p>  <p>Low-profile rectangular in-line fans</p> <p>28</p>	<p>TUB</p>  <p>In-line fans for high temperatures</p> <p>35</p>

CENTRIFUGAL FANS

<p>CBD CBD 3V</p>  <p>Low-pressure, double-inlet centrifugal fans with direct motor</p> <p>37</p>	<p>CJBD CJBD/AL</p>  <p>Ventilation units with direct motor and double-inlet fan</p> <p>42</p>	<p>CBX CBXC CBXR CBXT</p>  <p>Low-pressure, double-inlet belt-driven centrifugal fans</p> <p>44</p>	
<p>CJBX CJBX/AL</p>  <p>Belt-driven ventilation units with double-inlet fan</p> <p>54</p>	<p>CDXR CDXRT CJDXR</p>  <p>Belt-driven fans with double-inlet</p> <p>63</p>	<p>CSXR CSXRT CJSXR</p>  <p>Belt-driven fans with single-inlet</p> <p>71</p>	
<p>TSA TSAT CJTSA</p>  <p>Belt-driven fans with single-inlet</p> <p>83</p>	<p>TWIN</p>  <p>Ventilation units with direct motor and two independent fans</p> <p>91</p>	<p>KIT DE SOBREPRESIÓN</p>  <p>93</p>	<p>BR</p>  <p>High-performance centrifugal fans of the PLUG FAN type</p> <p>97</p>

<p>CJBR</p>  <p>Ventilation units with backward-curved impeller</p> <p>99</p>	<p>CJEC</p>  <p>400°C/2h kitchen extraction units with two-speed motor</p> <p>101</p>	<p>CB</p>  <p>Centrifugal medium-pressure fans with multi-blade impeller</p> <p>104</p>	<p>CPV</p>  <p>Plastic anticorrosive centrifugal fans</p> <p>107</p>
<p>CMA</p>  <p>Centrifugal medium-pressure fans made from cast aluminium</p> <p>112</p>	<p>CMC</p>  <p>Centrifugal high-pressure fans made from sheet steel</p> <p>115</p>	<p>COMP</p>  <p>Centrifugal medium-pressure fans fitted with multi-blade impeller.</p> <p>117</p>	<p>CMP/AL CJMP/AL</p>  <p>Centrifugal medium-pressure fans fitted with multi-blade impeller.</p> <p>124</p>
<p>CMRE</p>  <p>Centrifugal single-inlet, medium-pressure fans fitted with an impeller with backward-facing blades and external rotor motor</p> <p>126</p>	<p>CMR</p>  <p>Robust centrifugal medium-pressure fans fitted with backward-curved impeller</p> <p>128</p>	<p>CBP CBPC</p>  <p>Centrifugal medium-pressure fans without stands, fitted with backward-curved impeller and vertical outlet</p> <p>134</p>	<p>CAS CAS-S</p>  <p>Centrifugal high-pressure fans made from sheet steel with built-in noise reducer</p> <p>137</p>
<p>CA</p>  <p>Centrifugal high-pressure fans made from cast aluminium</p> <p>143</p>	<p>CAM</p>  <p>Centrifugal high-pressure fans made from sheet steel</p> <p>146</p>	<p>CAS-X</p>  <p>Centrifugal belt-driven fans with electric motor</p> <p>149</p>	<p>CMP-X</p>  <p>Robust centrifugal medium-pressure belt-driven fans fitted with backward-curved or multi-blade impeller</p> <p>156</p>
<p>CMR-X</p>  <p>Robust centrifugal medium-pressure belt-driven fans fitted with backward-curved or multi-blade impeller</p> <p>164</p>	<p>CMRH</p>  <p>Centrifugal belt-driven fans to re-circulate hot gases</p> <p>177</p>	<p>CMSH</p>  <p>Centrifugal fans to re-circulate hot gases, with a direct motor and backward-curved or multi-blade impeller</p> <p>179</p>	<p>CMPH</p>  <p>Centrifugal fans to re-circulate hot gases, with a direct motor and backward-curved or multi-blade impeller</p> <p>182</p>
<p>CMAT</p>  <p>Centrifugal medium-pressure fans to transport solids</p> <p>185</p>	<p>CMT</p>  <p>Centrifugal medium-pressure fans to transport solids</p> <p>188</p>	<p>CAST</p>  <p>Centrifugal high-pressure fans to transport solids</p> <p>191</p>	

NEW SERIES. NEW PRODUCTS.
NEW CATALOGUES.
 NEW BUSINESS OPPORTUNITIES.



Ask us for information



AXIAL AND
 ROOF FANS



CENTRIFUGAL
 AND IN-LINE
 DUCT FANS



LOW-PRESSURE
 CENTRIFUGAL
 FANS



FANS FOR
 SMOKE
 EXTRACTION



FANS FOR
 ATEX EXPLOSIVE
 ATMOSPHERES



VENTILATION SYSTEM
 FOR HOUSES



HEAT RECOVERY
 SYSTEMS AND
 FILTRATION UNITS



AIR CURTAINS
 FOR DOMESTIC AND
 COMMERCIAL
 APPLICATIONS

Crta. de Berga, km 0.7
 E-08580 St. Quirze de Besora
 BARCELONA (Spain)
 Tel. +34 93 852 91 11
 Fax. +34 93 852 90 42
 comercial@sodeca.com
 Export sales: ventilation@sodeca.com
 www.sodeca.com



FULFILMENT OF STANDARDS

SODECA's fans and extractors comply with the following standards:

QUALITY	
ISO 9001:2008	Sistemas de gestión de la calidad. Requisitos. Quality management systems -- Requirements
TESTS	
ISO 5801	Ventiladores industriales. Industrial fans -- Performance testing using standardized airways Industrial fans -- Performance testing using standardized airways
AMCA 210-99	Ventiladores industriales. Métodos de ensayos de ventiladores y su representación de ensayos. Laboratory Methods of Testing Fans for Aerodynamic Performance Rating
UNE 100212:1990	Ventiladores. Dispositivos e instalaciones para el ensayo de ventiladores.
ISO 13350	Ventiladores industriales. Ensayos de comportamiento de ventiladores de chorro. Industrial fans -- Performance testing of jet fans
ISO 13348	Industrial fans -- Tolerances, methods of conversion and technical data presentation
FANS FOR HIGH TEMPERATURES	
EN 12101-3:2002	Sistemas de control de humos y calor. Parte 3: Especificaciones para aireadores extractores de humos y calor mecánicos. Smoke and heat control systems - Part 3: Specification for powered smoke and heat exhaust ventilators
ACOUSTICS	
ISO 3744	Acústica. Determinación de los niveles de potencia acústica de fuentes de ruido a partir de la presión acústica. Método de ingeniería para condiciones de campo libre sobre un plano reflectante. Acoustics -- Determination of sound power levels of noise sources using sound pressure -- Engineering method in an essentially free field over a reflecting plane
BALANCE AND VIBRATIONS	
ISO 1940-1	Vibraciones mecánicas. Calidad de equilibrado Mechanical vibration -- Balance quality requirements for rotors in a constant (rigid) state -- Part 1: Specification and verification of balance tolerances
ISO 10816-1	Vibraciones mecánicas. Evaluación de las vibraciones de máquinas Mechanical vibration -- Evaluation of machine vibration by measurements on non-rotating parts -- Part 1: General guidelines
ISO 14694	Ventiladores industriales. Especificaciones para equilibrado y niveles de vibración Industrial fans -- Specifications for balance quality and vibration levels
SAFETY (Declaration of EC Compliance)	
EN ISO 12100-1	Seguridad de las máquinas. Conceptos básicos, principios generales para el diseño. Parte 1: Terminología básica, metodología. Safety of machinery -- Basic concepts, general principles for design -- Part 1: Basic terminology, methodology
EN ISO 12100-2	Seguridad de las máquinas. Conceptos básicos, principios generales para el diseño. Parte 2: Principios técnicos. Safety of machinery -- Basic concepts, general principles for design -- Part 2: Technical principles
EN 60204-1	Seguridad de las máquinas. Equipo eléctrico de las máquinas. Parte 1: Requisitos generales. Safety of machinery - Electrical equipment of machines - Part 1: General requirements
EN 294	Seguridad de máquinas. Distancias de seguridad para impedir que se alcancen zonas peligrosas con los miembros superiores Safety of machinery; safety distances to prevent danger zones from being reached by the upper limbs
ISO 13857	Seguridad de máquinas. Distancias de seguridad para impedir que se alcancen zonas peligrosas con los miembros superiores e inferiores. Safety of machinery -- Safety distances to prevent danger zones being reached by upper and lower limbs
UNE 100250	Ventiladores industriales. Seguridad mecánica de los ventiladores (equivalente ISO 12499)
ISO 12499	Ventiladores industriales. Seguridad mecánica en los ventiladores Industrial fans -- Mechanical safety of fans -- Guarding
DIRECTIVES	
Directiva 2006/42/CE	Directiva de máquinas Machinery Directive
Directiva 2006/95/CE	Directiva de baja tensión Low Voltage Directive
Directiva 2004/108/CE	Directiva compatibilidad electromagnética EMC Directive
Directiva 89/106/CE	Directiva productos de construcción Construction Products Directive (CPD)
ATEX EXECUTIONS	
Directiva ATEX 94/9/CE	Aparatos y sistemas de protección para uso en atmósferas potencialmente explosivas Equipment and protective systems intended for use in potentially explosive atmospheres
EN 14986	Diseño de ventiladores para trabajar en atmósferas potencialmente explosivas. Design of fans working in potentially explosive atmospheres
EN 13463-1	Equipos no eléctricos destinados a atmósferas potencialmente explosivas. Parte 1: Requisitos y metodología básica. Non-electrical equipment for use in potentially explosive atmospheres - Part 1: Basic method and requirements
EN 1127-1	Atmósferas explosivas. Prevención y protección contra la explosión. Parte 1: Conceptos básicos y metodología. Explosive atmospheres - Explosion prevention and protection - Part 1: Basic concepts and methodology



Our design, research and development department is working intensively to improve the quality and efficiency of our products day by day.

DESIGN, RESEARCH AND DEVELOPMENT

The modern facilities of our aerodynamic testing laboratory with an area of 450 m², are the nerve centre for the development of all our products. Here we obtain maximum reliability in the results from the strict checks to which we base both products and manufacturing processes.

We have also begun a new stage of study and design of new trends in ventilation which will help to preserve the environment and to make energy savings.

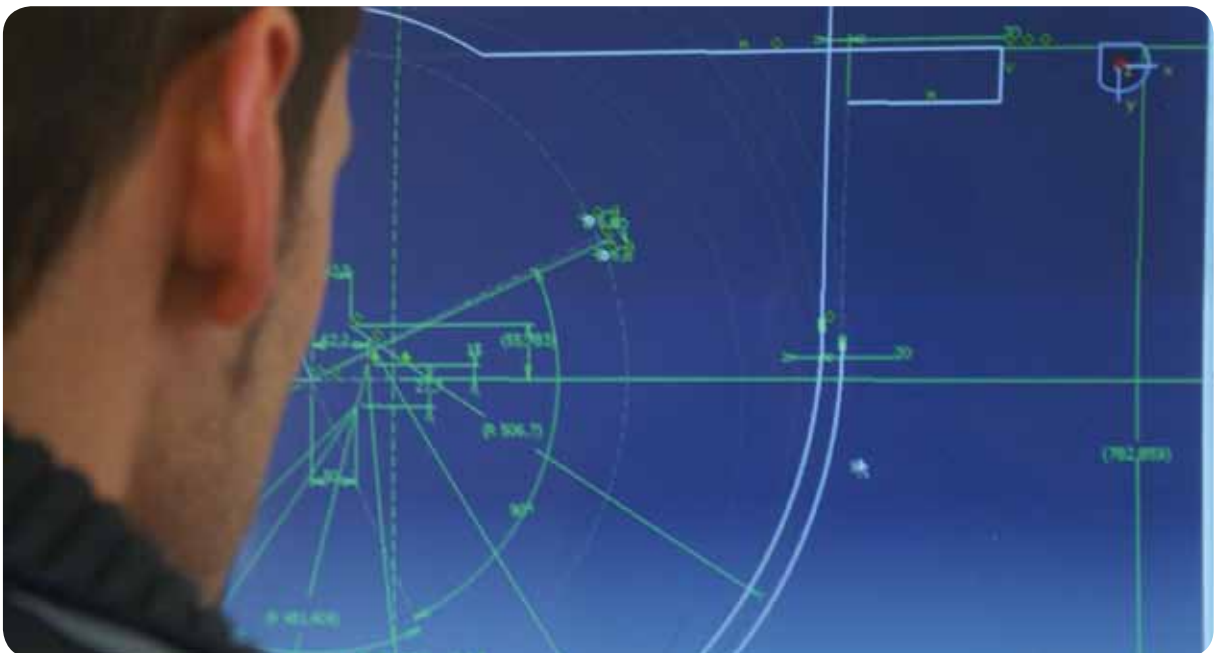
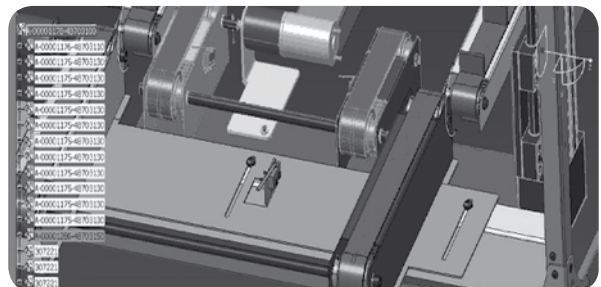



OUR IMPELLERS

CSXR Impeller

Single-inlet medium-pressure multi-blade impeller with backward-curved blades



NEOLINEO Impeller

A helico-centrifugal impeller, for linear air circulation, with high pressures



CMR Impeller

Robust single-inlet impeller with backward-curved blades for large flows and pressure, with high performance



CBD Impeller

Double inlet multi-blade impeller with forward-facing blades, for low pressure



CMRH Impeller

Robust single-inlet impeller with backward-curved blades, designed for working at high temperatures



CDXR Impeller

Double inlet backward-curved blades impeller for large flows



CA-CAM Impeller

Impellers designed to obtain high pressure



CMP Impeller

Single-inlet medium-pressure multi-blade impeller with forward-facing blades



CMT Impeller

Robust impellers, designed to transport dust and solids materials

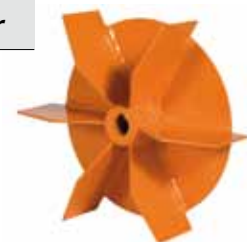

SV SV/PLUS SV/ECO

SV: Low noise in-line duct fans mounted in acoustic casing
SV/PLUS: Low noise in-line duct fans mounted in acoustic casing with 50mm insulation
SV/ECO: Low noise in-line duct fans mounted in acoustic casing with 50 mm insulation, fitted with EC motors



SV



SV/PLUS



SV/ECO

Fan:

- Acoustic casing covered with deadening material
- SV: Impeller with backward-curved blades, except models 125-150-200, with multi-blade impeller
- SV/PLUS: Multi-blade impeller for all models
- SV/ECO: Backward-curved impeller for all models
- Standard flanged inlet and outlet to aid installation on duct
- They are supplied with 4 base stands to aid installation
- Linear air circulation
- T-models are fitted with 1-5 minute adjustable timer.

Motor:

- Class F motors with external rotor incorporated thermal protector, ball bearings and IP54 protection
- Single-phase 230V.-50/60Hz. adjustable
- Max. air temperature to transport: + 50°C.
- SV/ECO: Highly-efficient brushless-EC motor, electronically controlled by means of a potentiometer of 10KΩ MTP010, or an external signal of 0-10VDC

Finish:

- Anticorrosive finish in polyester resin, polymerised at 190°C, after alkaline degreasing and phosphate-free pre-treatment.

Order code

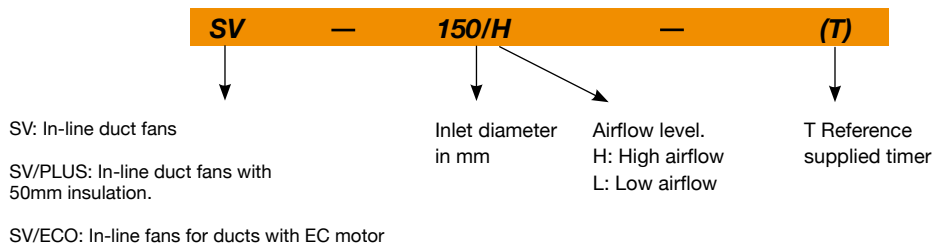

Technical characteristics

Model	Speed (r/min)	Maximum admissible current 230V (A)	Installed Power (kW)	Maximum Airflow (m³/h)	Irradiated sound level dB(A)	Approx. weight (Kg)
SV-125/H	2220	0.65	0.08	400	32	5.2
SV-125/H-T	2220	0.65	0.08	400	32	5.2
SV-150/H	2200	1.25	0.17	560	40	6.8
SV-150/H-T	2200	1.25	0.17	560	40	6.8
SV-200/H	1240	0.85	0.12	880	44	8.0
SV-200/H-T	1240	0.85	0.12	880	44	8.0
SV-200/L	1280	0.75	0.10	760	42	8.0
SV-250/H	2380	0.95	0.14	1300	48	10.8
SV-250/L	2360	0.85	0.12	1000	46	10.8
SV-315/H	1330	0.75	0.12	2100	50	21.0
SV-350/H	1280	0.95	0.14	2850	51	28.5
SV-400/H	1400	1.80	0.30	3500	53	38.0

Technical characteristics

Model	Speed (r/min)	Maximum admissible current (A)		Installed Power (kW)	Maximum Airflow (m³/h)	Irradiated sound level* dB(A)	Approx. weight (Kg)
		230V					
SV/PLUS-125/H	2335	0.33		0.08	260	30	12.0
SV/PLUS-160/H	2480	0.59		0.14	465	36	13.0
SV/PLUS-200/H	1550	0.72		0.17	700	37	17.0
SV/PLUS-250/H	2082	1.15		0.27	1050	38	18.0

* Sound pressure level dB(A) are measurements at a distance of 1.5 meters

Model	Speed (r/min)	Maximum admissible current (A)		Installed Power (kW)	Maximum Airflow (m³/h)	Sound pressure level to 50% of maximum speed* dB(A)	Approx. weight (Kg)
		230V					
SV/ECO-125/H	4480	0.46		0.055	367	29	12.0
SV/ECO-160/H	3490	0.99		0.114	565	28	19.0
SV/ECO-200/H	3380	1.48		0.192	914	39	24.0
SV/ECO-250/H	3220	1.69		0.213	1107	32	24.0
SV/ECO-315/H	3580	2.8		0.448	1638	49	31.0

* Sound pressure level dB(A) are measurements at a distance of 1.5 meters

Acoustic features

The specified values are determined according to free field measurements of sound levels in dB(A) at an equivalent distance of twice the fan's span plus the impeller's diameter, with a minimum of 1.5 m.

Sound power Lw(A) spectrum in dB(A) via frequency band in Hz.

Model	63	125	250	500	1000	2000	4000	8000	Model	63	125	250	500	1000	2000	4000	8000
125/H	22	32	36	34	33	34	30	24	SV/PLUS-125/H	35	46	52	57	64	62	55	48
150/H	31	41	42	44	45	46	42	36	SV/PLUS-160/H	43	54	61	66	72	71	67	63
200/H	31	42	47	51	50	47	43	33	SV/PLUS-200/H	43	55	58	62	69	68	66	61
200/L	29	39	46	47	47	46	45	37	SV/PLUS-250/H	49	58	64	70	72	80	70	65
250/H	32	42	47	54	55	53	50	41									
250/L	33	43	47	53	51	50	48	41									
315/H	34	44	49	56	57	55	52	43									
350/H	38	48	52	59	60	58	56	47									
400/H	40	50	54	61	62	60	58	49									

Dimensions in mm

SV

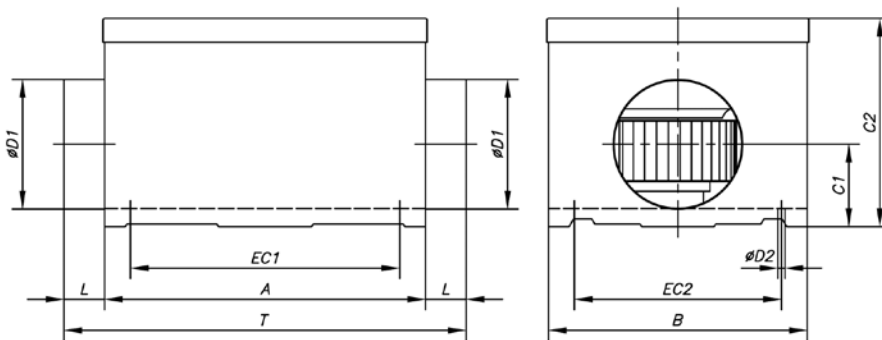

Model	A	B	C1	C2	øD1	L	øD2	EC1	EC2	T
SV-125/H	310	250	80	201	125	36.5	7	260	200	383
SV-150/H	370	290	92	222	150	34.5	7	320	240	439
SV-200/H	430	340	117	246	200	34.5	7	380	290	499
SV-200/L	430	340	117	246	200	34.5	7	380	290	499
SV-250/H	480	395	140	296	250	51.5	7	430	345	583
SV-250/L	480	395	140	296	250	51.5	7	430	345	583
SV-315/H	565	490	173.5	370	315	55	8.5	515	440	675
SV-350/H	650	550	200	410	355	57	8.5	600	500	764
SV-400/H	725	610	200	454	400	70	8.5	675	560	865

Dimensions in mm

SV/PLUS

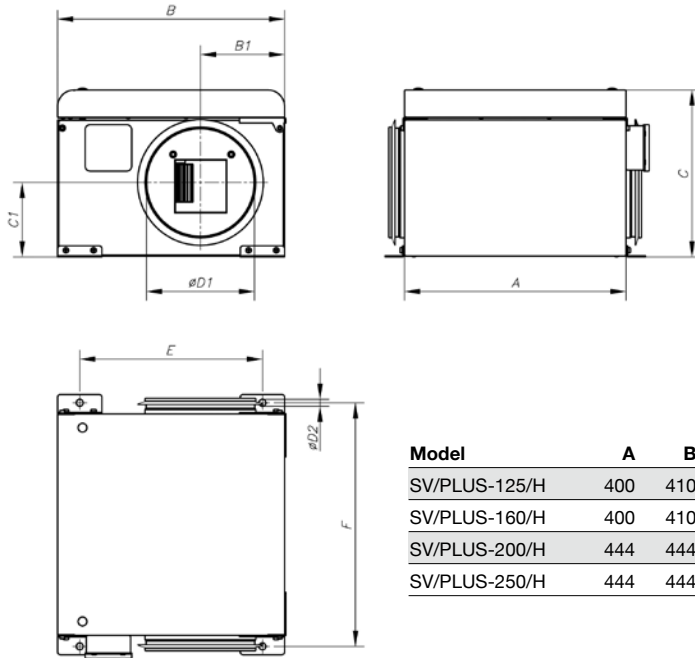

Model	A	B	B1	C	C1	øD1	øD2	E	F
SV/PLUS-125/H	400	410	277	300	171.5	125	12.5	330	440
SV/PLUS-160/H	400	410	148.5	300	142.5	160	12.5	330	440
SV/PLUS-200/H	444	444	222	420	251.5	200	12.5	364	484
SV/PLUS-250/H	444	444	222	420	221.5	250	12.5	364	484

SV/ECO

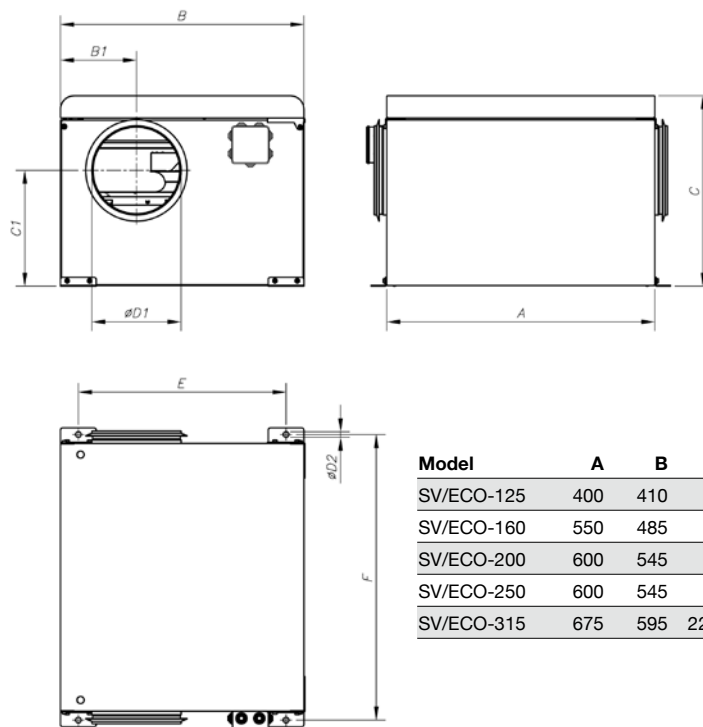

Model	A	B	B1	C	C1	øD1	øD2	E	F
SV/ECO-125	400	410	205	325	165.5	125	12.5	330	440
SV/ECO-160	550	485	149	340	194.5	160	12.5	405	590
SV/ECO-200	600	545	170	425	259.5	200	12.5	465	640
SV/ECO-250	600	545	194	425	234.5	250	12.5	465	640
SV/ECO-315	675	595	227.5	475	251.5	315	12.5	515	715

Characteristic curves

Q = Airflow in m³/h, m³/s and cfm.

Pe = Static pressure in mm.w.c., Pa and in wg.

SV

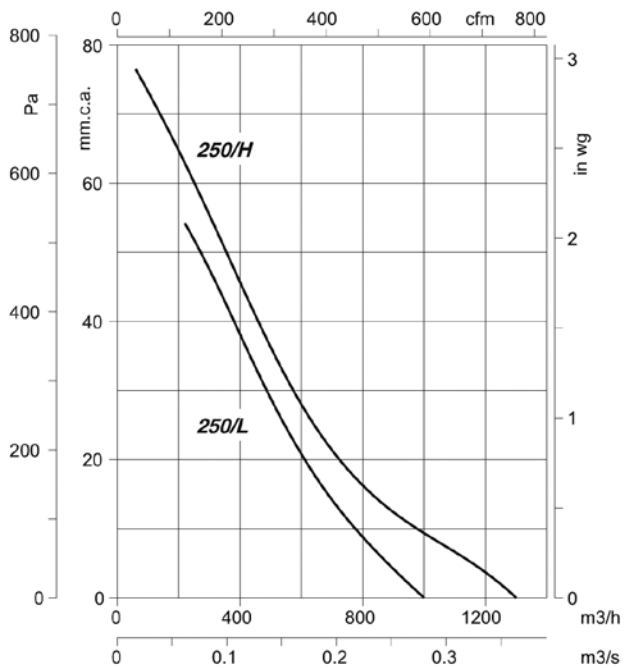
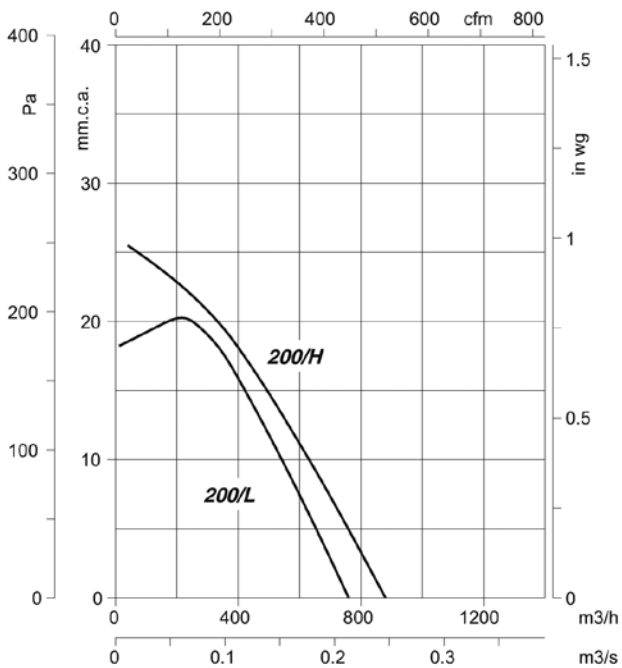
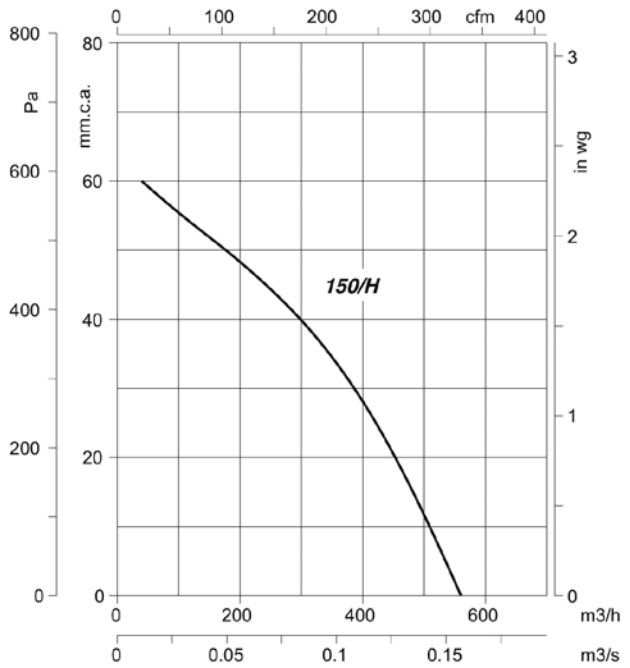
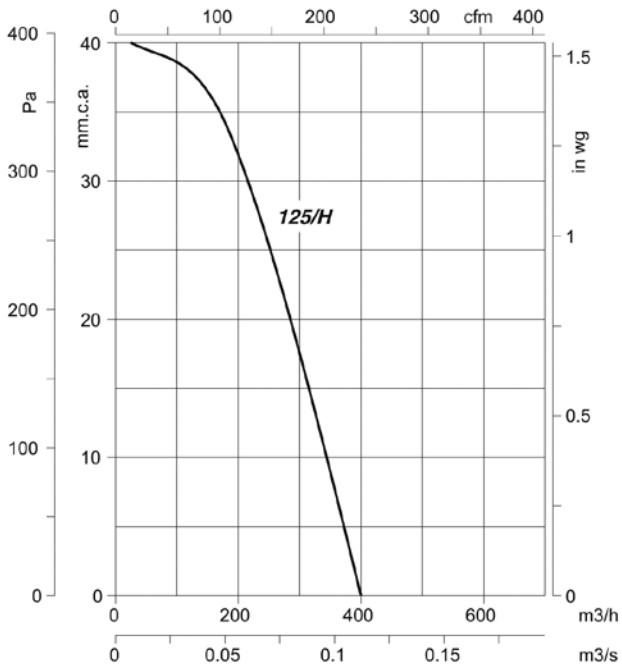

Characteristic curves

Q = Airflow in m³/h, m³/s and cfm.

Pe = Static pressure in mm.w.c., Pa and in wg.

SV

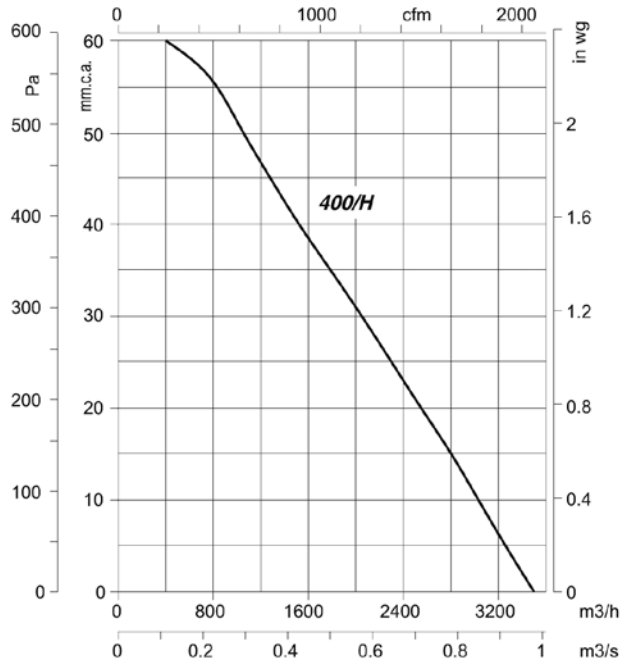
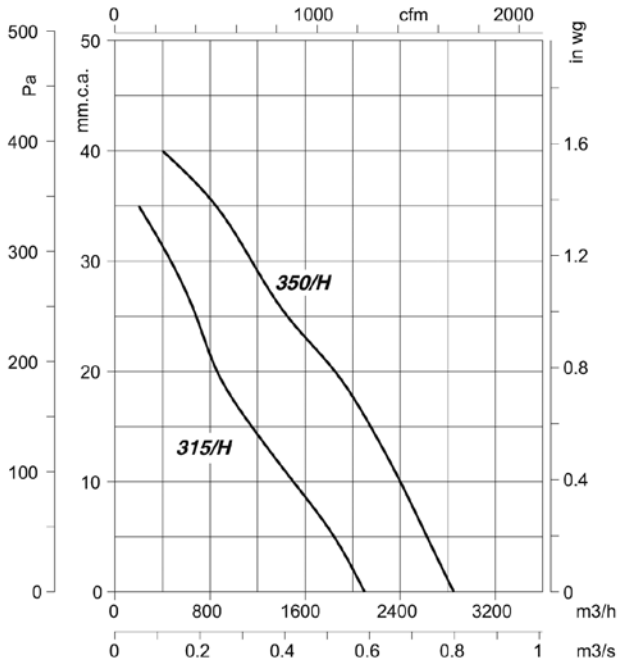

SV/PLUS

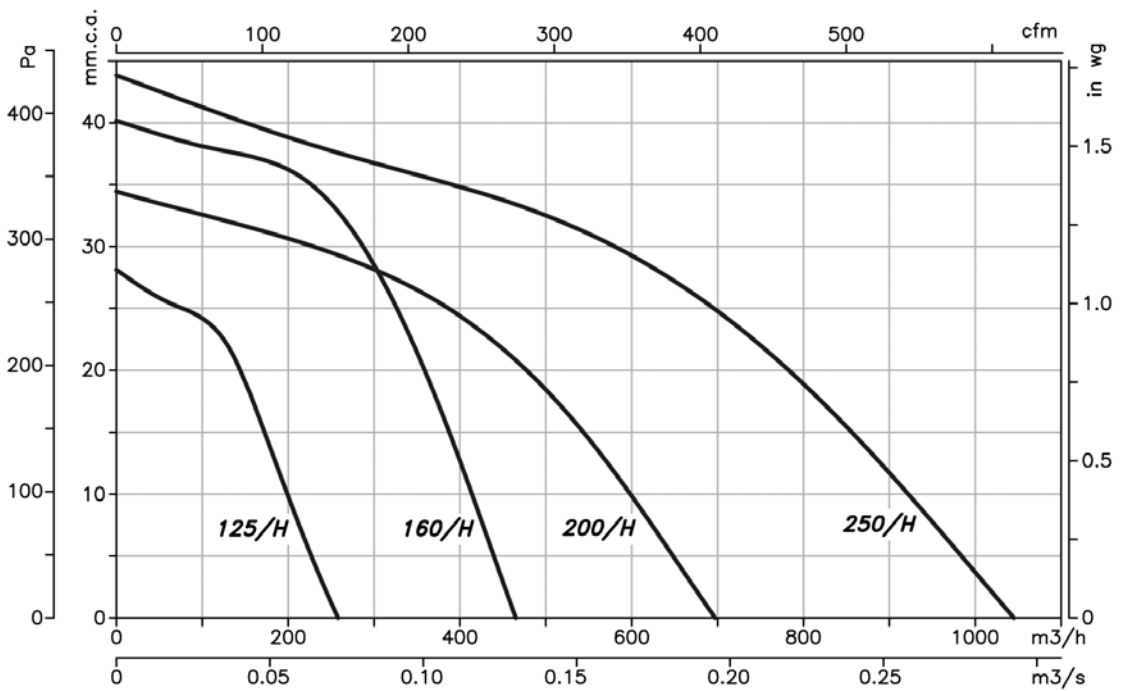

Characteristic curves

Q = Airflow in m³/h, m³/s and cfm.

Pe = Static pressure in mm.w.c., Pa and in wg.

SV/ECO

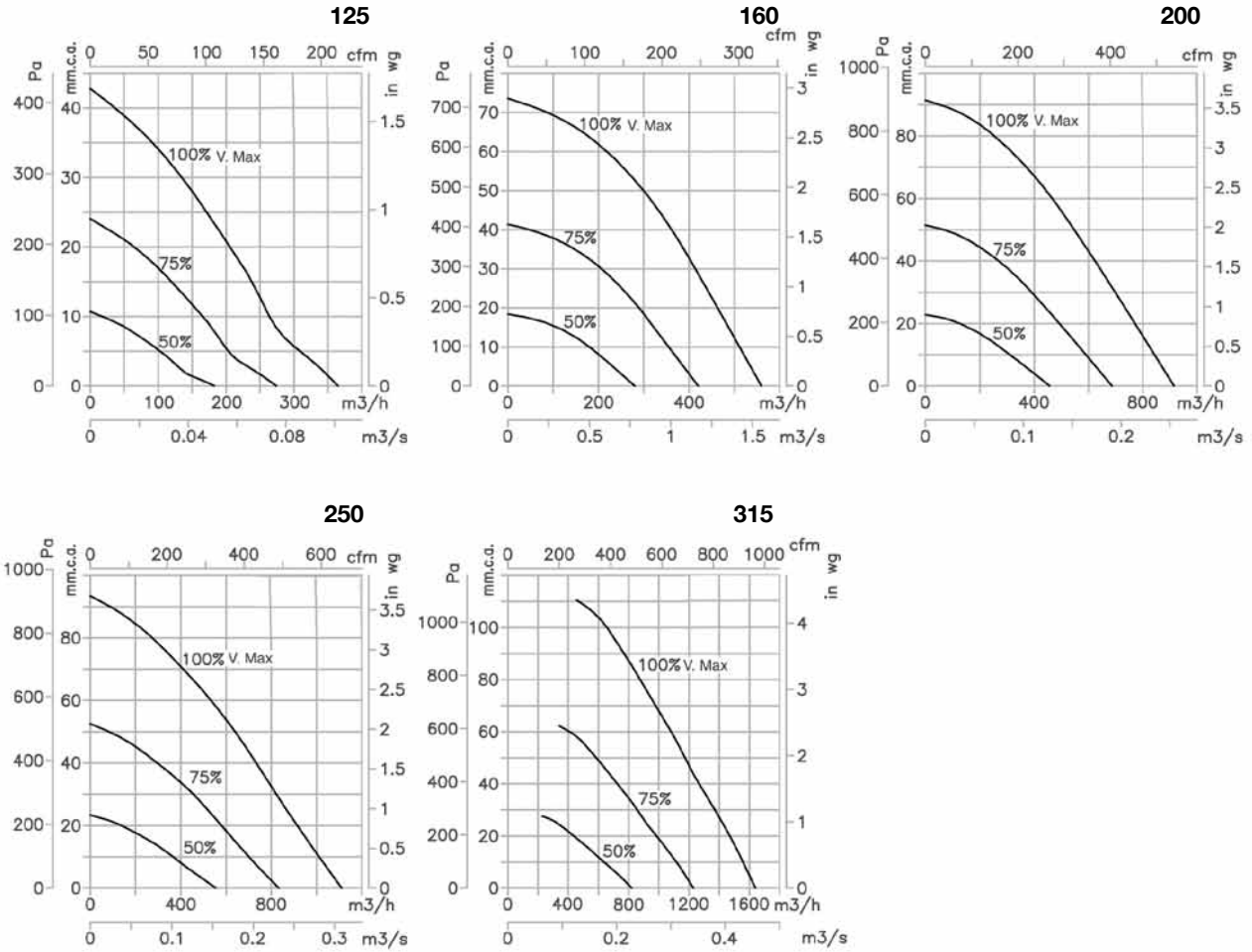

Accessories

See the accessories section.



CJBC CJBC/ECO

CJBC: Compact extraction units direct drive for community housing
CJBC/ECO: Compact extraction units direct drive for community housing with constant pressure control.

Fan:

- Galvanised sheet steel structure with thermal insulation and soundproofing.
- Impeller with forward-facing blades made from galvanised sheet steel
- Stuffing-box for cable input
- CJBC/ECO: It incorporates a low-pressure switch and speed regulator by means of a frequency converter to maintain a constant pressure

Motor:

- Class F closed motors with incorporated thermal protector, ball bearings and IP-54 protection
- Single-phase 220-240V.-50Hz. and three-phase 220-240/380-415V.-50Hz.
- Max. air temperature to transport: -20°C.+ 60°C.

Finish:

- Anticorrosive galvanized sheet steel.

On request:

- With circular inlet



CJBC



CJBC/ECO

Example of use

SELF-REGULATING CONTROL OPTION



CJBC



BE ALIZE



EA



MOISTURE-REGULATING CONTROL OPTION



CJBC/ECO



BE ALIZE-H



EA-A-HY

Order code

CJBC	—	2525	—	6M	—	1/3	—	CIR
↓		↓		↓		↓		↓
CJBC: Compact extraction units direct drive for community housing		Impeller size in mm mm inches		Number of motor poles 4=1400 r/min. 50 Hz 6=900 r/min. 50 Hz		T=Three-phase M=Single-phase Power motor (c.v.)		Circular inlet/outlet
CJBC/ECO: Compact extraction units direct drive for community housing with constant pressure control.		1919 7/7 2525 9/9 2828 10/10 3333 12/12 3939 15/15						

Technical characteristics

Model	Speed (r/min)	Equivalent Inches	Maximum admissible current (A)		Installed Power (kW)	Maximum Airflow (m³/h)	Sound pressure level dB(A)	Approx. weight (Kg)
			230V	400V				
CJBC-1919-4M 1/5	1230	7/7	1,75		0,15	1368	58	15,7
CJBC-1919-6M 1/10	820	7/7	0,98		0,07	1107	53	15,7
CJBC-2525-4M 3/4	1310	9/9	4,50		0,55	3240	70	23,3
CJBC-2525-6M 1/3	830	9/9	2,40		0,25	2430	61	22,3
CJBC-2828-4M 3/4	1310	10/10	4,50		0,55	3555	70	27,3
CJBC-2828-6M 1/3	830	10/10	2,40		0,25	2880	61	26,2
CJBC-3333-6M 1	850	12/12	6,30		0,75	5400	70	38,3
CJBC-3333-6T 1 1/2	900	12/12	6,60	3,80	1,10	7020	74	38,7
CJBC-3939-6T 3	890	15/15	10,90	6,30	2,20	10710	74	58,0
CJBC/ECO-3333-6T 1 1/2	900	12/12	6,6	3,8	1,1	7020	74	40,6
CJBC/ECO-3939-6T 3	890	15/15	10,9	6,3	2,2	10710	74	60,0

Acoustic features

The specified values are determined according to free field measurements of sound levels in dB(A) at an equivalent distance of twice the fan's span plus the impeller's diameter, with a minimum of 1.5 m.

Sound power Lw(A) spectrum in dB(A) via frequency band in Hz. Maximum speed

Model	63	125	250	500	1000	2000	4000	8000	Model	63	125	250	500	1000	2000	4000	8000
CJBC-1919-4M 1/5	43	54	58	62	64	63	62	53	CJBC-3333-6M 1	55	66	70	74	76	75	74	65
CJBC-1919-6M 1/10	38	49	53	57	59	58	57	48	CJBC-3333-6T 1 1/2	59	70	74	78	80	79	78	69
CJBC-2525-4M 3/4	55	66	70	74	76	75	74	65	CJBC-3939-6T 3	61	72	77	81	83	81	80	71
CJBC-2525-6M 1/3	46	57	61	65	67	66	65	56	CJBC/ECO-3333-6T 1 1/2	59	70	74	78	80	79	78	69
CJBC-2828-4M 3/4	55	66	70	74	76	75	74	65	CJBC/ECO-3939-6T 3	61	72	77	81	83	81	80	71
CJBC-2828-6M 1/3	46	57	61	65	67	66	65	56									



Version with circular inlet/outlet

Dimensions in mm

CJBC

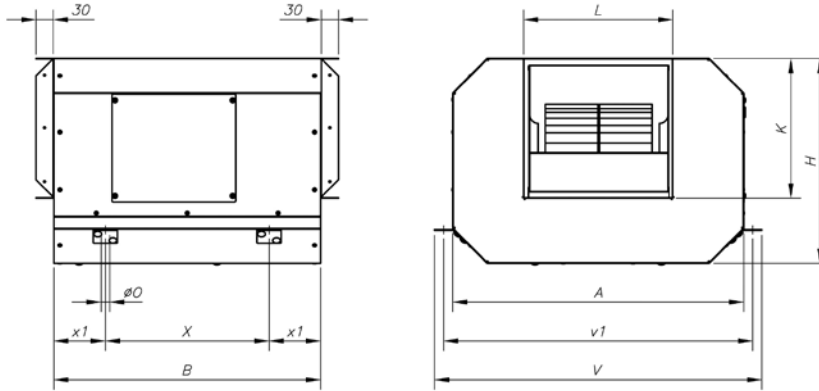

Model	A	B	H	K	L	øO	V	v1	X	x1
CJBC-1919-4M-1/5	480	440	340	210	225	15	540	510	270	85
CJBC-1919-6M-1/10	480	440	340	210	225	15	540	510	270	85
CJBC-2525-4M-3/4	630	575	405	265	291	15	690	660	375	100
CJBC-2525-6M-1/3	630	575	405	265	291	15	690	660	375	100
CJBC-2828-4M-3/4	696	645	460	290	320	15	755	725	445	100
CJBC-2828-6M-1/3	696	645	460	290	320	15	755	725	445	100
CJBC-3333-6M-1	825	760	535	345	379	15	885	855	510	125
CJBC-3333-6T-1 1/2	825	760	535	345	379	15	885	855	510	125
CJBC-3939-6T-3	910	900	636	405	467	15	970	940	650	125

CJBC/ECO

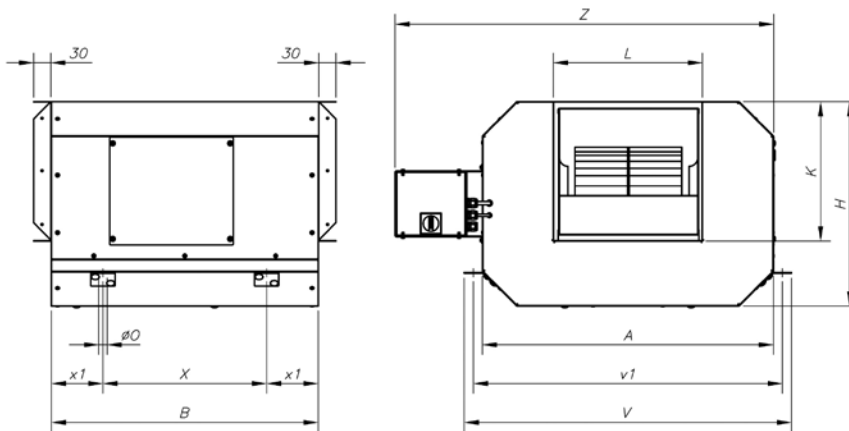

Model	A	B	H	K	L	øO	V	v1	X	x1	Z
CJBC/ECO-3333-6T-1 1/2	825	760	535	345	379	15	885	855	510	125	1080
CJBC/ECO-3939-6T-3	910	900	636	405	467	15	970	940	650	125	1200

Characteristic Curves

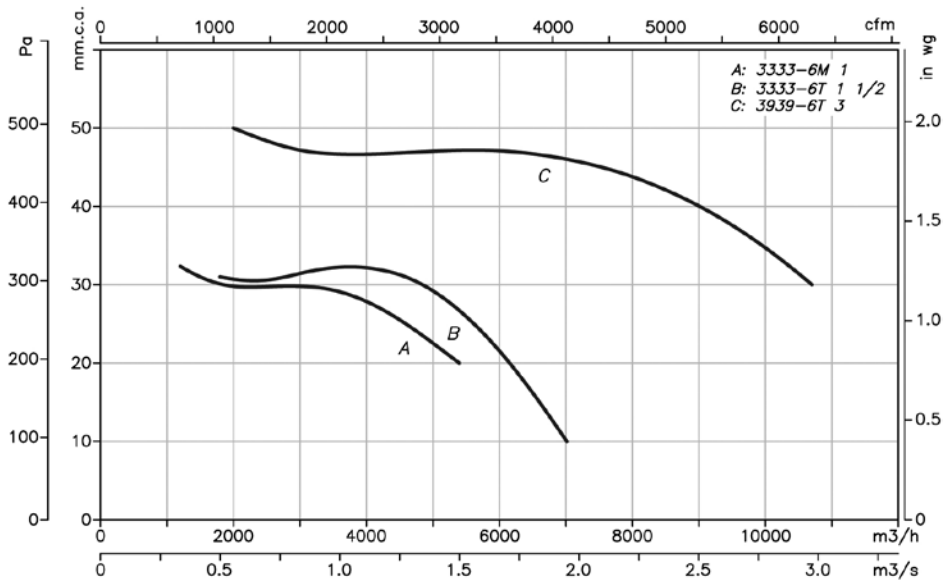
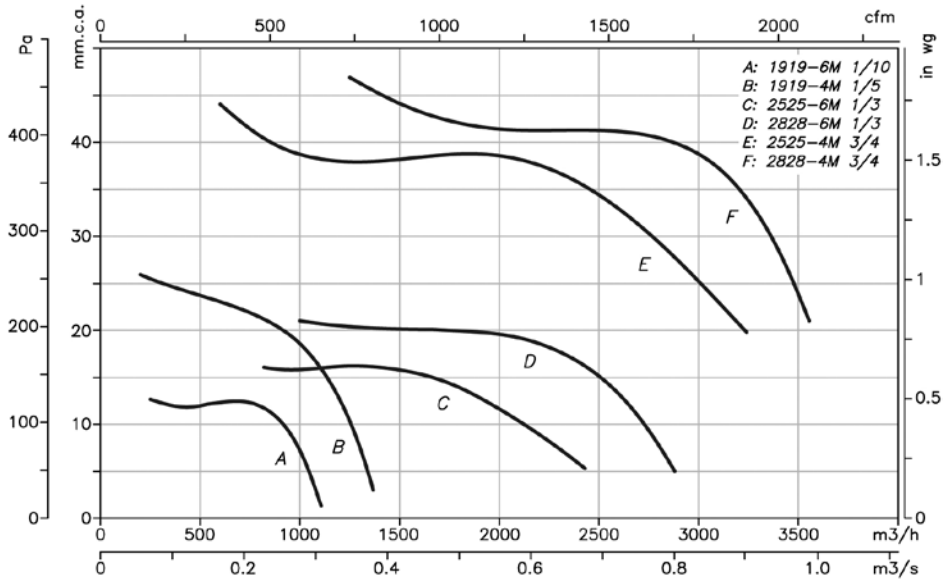

Accessories

See the accessories section.



NEOLINEO

In-line fans for small ducts with removable covers with Long Life ball bearings



Fan:

- V0 flame-retardant plastic casing
- External terminal board, with variable position
- Quick and easy to install
- T-models are fitted with timer

Motor:

- Motors with Long Life ball bearings, IPX4 protection, two-speed and adjustable
- Single-phase 220-240V, 50/60 Hz.
- Working temperature: -10°C +60°C

Finish:

- Made from white, V0 flame-retardant plastic

Order code

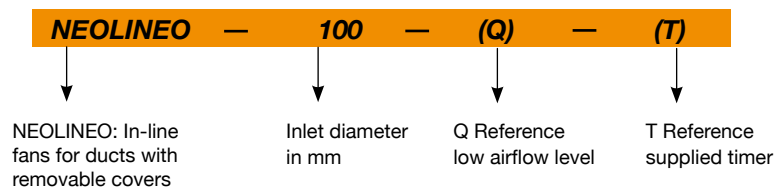

Technical characteristics

Model	Speed max / min. (r/min)	Maximum admissible current 230V (A)	Absorbed Power (W)	Maximum Airflow (m ³ /h)	Irradiated sound level* dB(A)	Approx. weight (Kg)
NEOLINEO-100-Q	2450 / 2070	0.07 / 0.05	15 / 12	200 / 155	29 / 25	1.22
NEOLINEO-100-Q T	2450 / 2070	0.07 / 0.05	15 / 12	200 / 155	29 / 25	1.22
NEOLINEO-100	2170 / 1590	0.11 / 0.09	23 / 20	255 / 180	30 / 25	1.795
NEOLINEO-100 T	2170 / 1590	0.11 / 0.09	23 / 20	255 / 180	30 / 25	1.8
NEOLINEO-125	2300 / 1600	0.15 / 0.11	33 / 25	365 / 250	33 / 27	1.8
NEOLINEO-125 T	2300 / 1600	0.15 / 0.11	33 / 25	365 / 250	33 / 27	1.8
NEOLINEO-150	2290 / 1520	0.26 / 0.18	58 / 40	550 / 385	33 / 28	2.4
NEOLINEO-150 T	2290 / 1520	0.26 / 0.18	58 / 40	550 / 385	33 / 28	2.4
NEOLINEO-160	2290 / 1520	0.26 / 0.18	58 / 40	550 / 385	34 / 28	2.4
NEOLINEO-160 T	2290 / 1520	0.26 / 0.18	58 / 40	550 / 385	34 / 28	2.4
NEOLINEO-200-Q	2720 / 1780	0.37 / 0.22	75 / 45	950 / 700	36 / 30	3.7
NEOLINEO-200	2390 / 1900	0.64 / 0.43	145 / 98	1060 / 790	38 / 32	3.7
NEOLINEO-200 T	2390 / 1900	0.64 / 0.43	145 / 98	1060 / 790	38 / 32	3.7
NEOLINEO-250-Q	2520 / 1740	0.5 / 0.4	110 / 85	990 / 720	39 / 37	7.1
NEOLINEO-250	2640 / 1950	0.78 / 0.48	180 / 110	1350 / 990	40 / 38	7.1
NEOLINEO-315	2500 / 1820	1.32 / 0.9	300 / 200	2300 / 1740	47 / 41	11.4

(*) The radiated sound pressure levels are free field measurements at 3 metres with rigid tubes during inlet and outlet.

Dimensions in mm

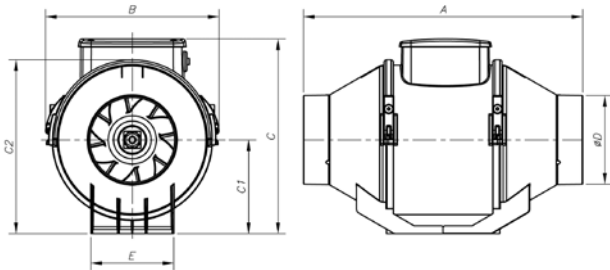

Model	A	B	C	C1	C2	øD	E
NEOLINEO-100-Q	231	156	174	82	152	96	95
NEOLINEO-100-Q T	231	156	174	82	152	96	95
NEOLINEO-100	303	188.5	211	101.5	189	96	90
NEOLINEO-100 T	303	188.5	211	101.5	189	96	90
NEOLINEO-125	258	188.5	211	101.5	189	122	90
NEOLINEO-125 T	258	188.5	211	101.5	189	122	90
NEOLINEO-150	294	214.5	234	112.5	212	146	110
NEOLINEO-150 T	294	214.5	234	112.5	212	146	110
NEOLINEO-160	272.5	214.5	234	112.5	212	156	110
NEOLINEO-160 T	272.5	214.5	234	112.5	212	156	110
NEOLINEO-200-Q	300	234.5	260.5	125.5	235	196	140
NEOLINEO-200	300	234.5	260.5	125.5	235	196	140
NEOLINEO-200 T	300	234.5	260.5	125.5	235	196	140
NEOLINEO-250-Q	385	300	317	152.5	292	247	176.5
NEOLINEO-250	385	300	317	152.5	292	247	176.5
NEOLINEO-315	448	361.5	392.5	188.5	359	312	220.5

Characteristic Curves

Q = Airflow in m³/h

Pe = Static pressure in mm.w.c., Pa

— Maximum speed
 - - - Minimum speed

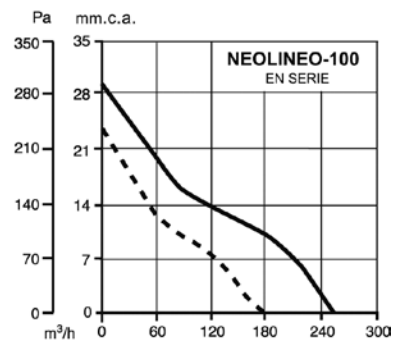
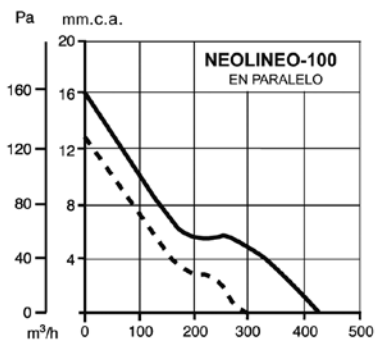
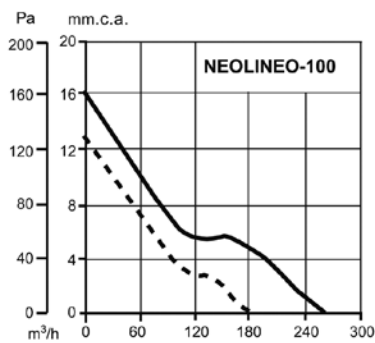
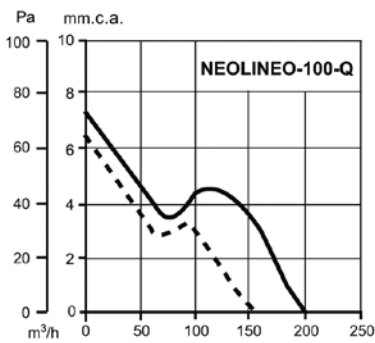

Characteristic Curves

Q = Airflow in m³/h
 Pe = Static pressure in mm.w.c., Pa

— Maximum speed
 - - - Minimum speed

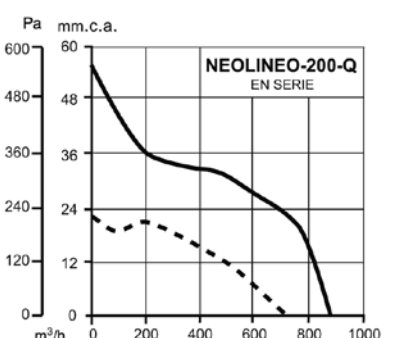
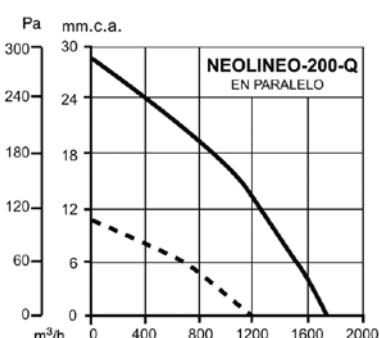
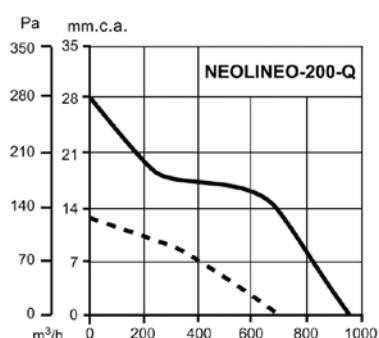
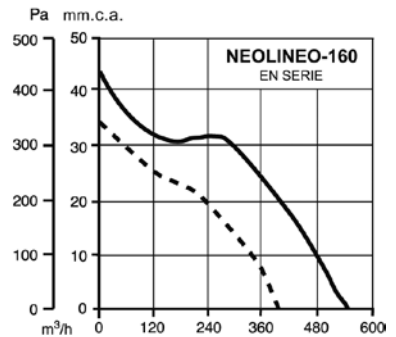
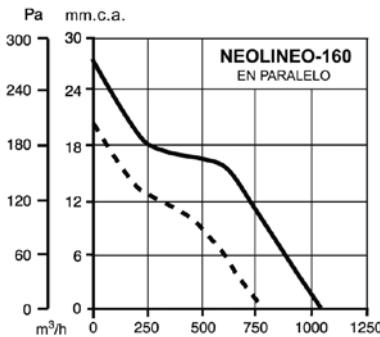
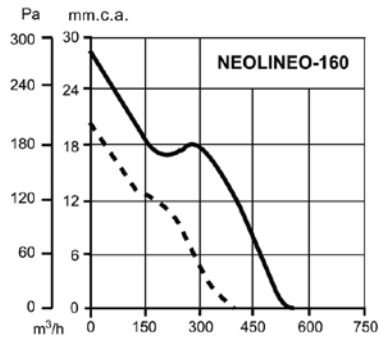
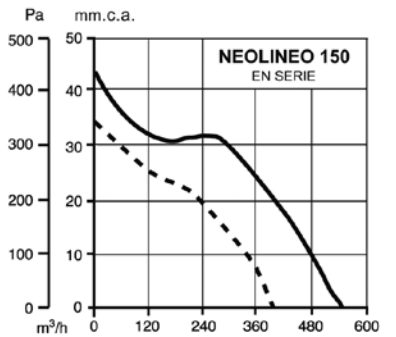
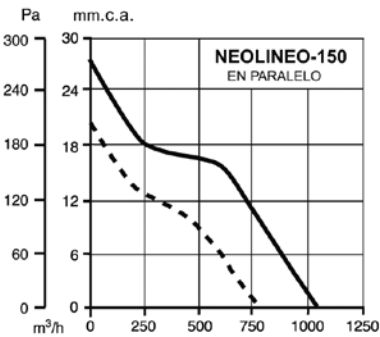
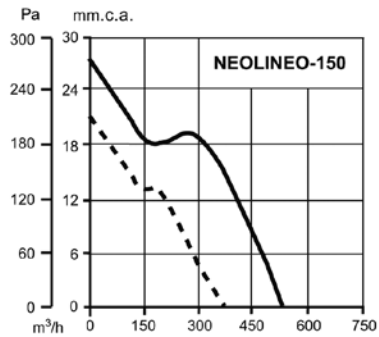
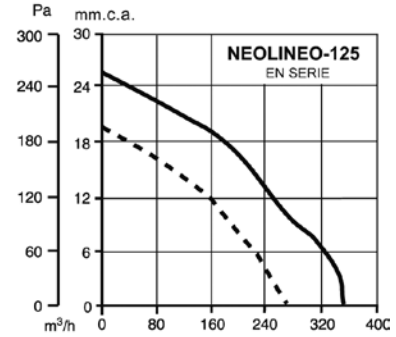
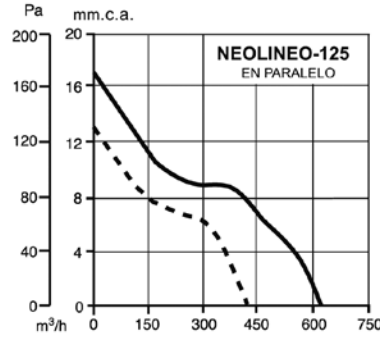
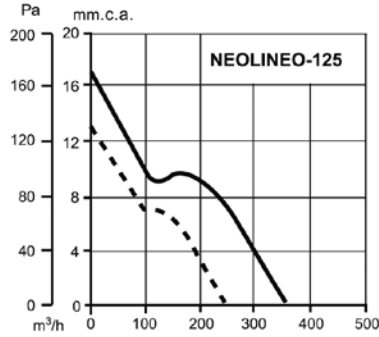

Characteristic Curves

Q = Airflow in m³/h
 Pe = Static pressure in mm.w.c., Pa

— Maximum speed
 - - - Minimum speed

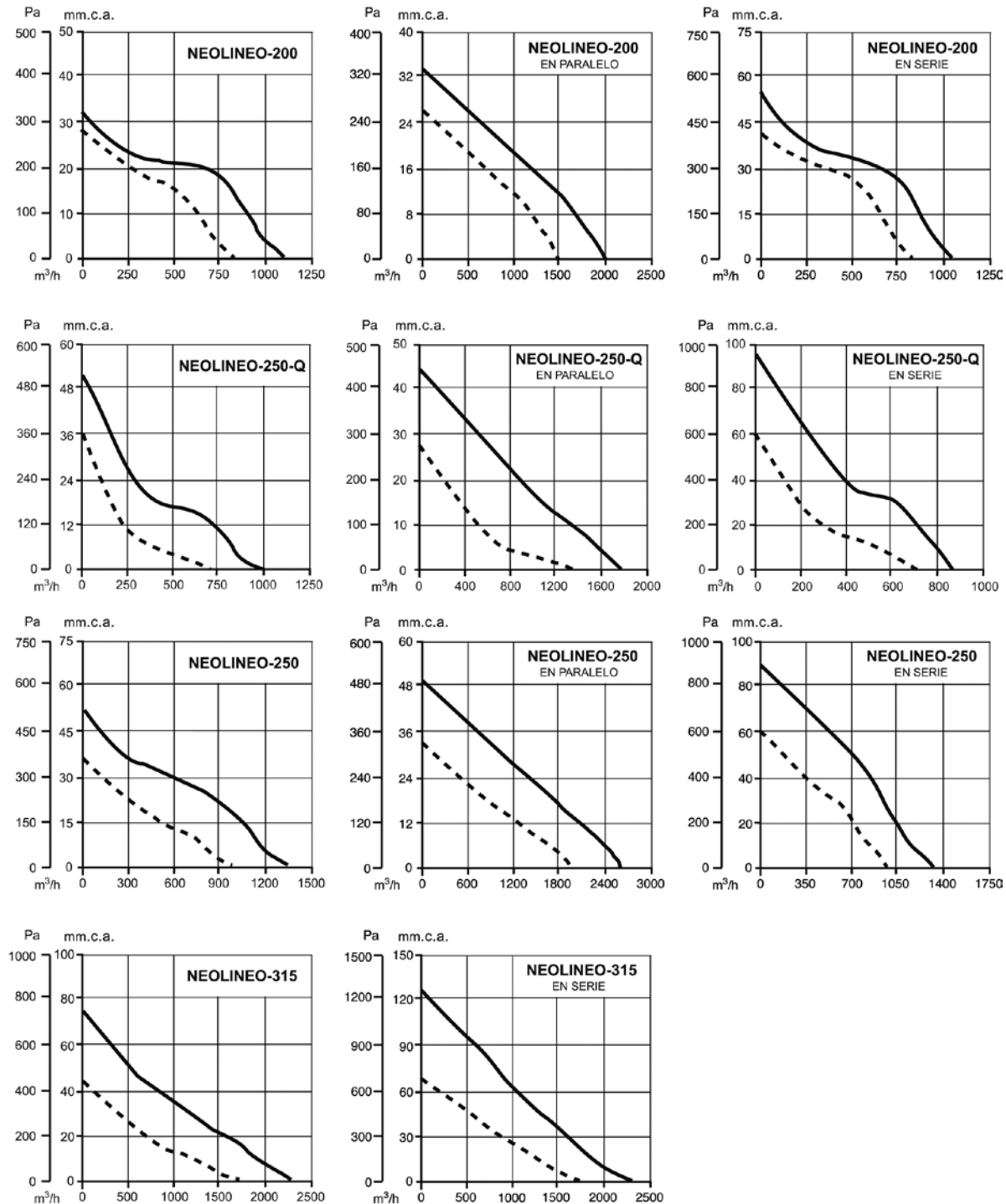

Accessories

See the accessories section.



CA/LINE

In-line circular fans for ducts with Long Life ball bearings



- Fan:
- Steel sheet casing
 - External terminal board
 - Quick and easy to install
 - Includes base stand

- Motor:
- Motors with Long Life ball bearings, IPX4 protection, two-speed and adjustable
 - Single-phase 220-240V. 50/60 Hz.
 - Working temperature: -10°C +60°C



Size 355

- Finish:
- Anticorrosive finish in polyester resin, polymerised at 190°C, after alkaline degreasing and phosphate-free pre-treatment.

Order code

CA/LINE — 200

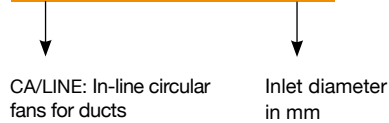

Technical characteristics

Model	Speed (r/min)	Maximum admissible current 230V (A)	Absorbed Power (kW)	Maximum Airflow (m³/h)	Sound pressure level dB(A)	Approx. weight (Kg)
CA/LINE-100	2478	0,27	0,063	260	33	3,0
CA/LINE-125	2514	0,29	0,067	350	35	3,0
CA/LINE-150	2503	0,43	0,100	537	41	4,0
CA/LINE-200	2518	0,71	0,162	980	36	5,0
CA/LINE-250	2518	0,71	0,162	1008	38	5,0
CA/LINE-315	2266	1,23	0,285	1596	37	6,5
CA/LINE-355	2098	1,56	0,357	2098	39	12,0

Acoustic features

The specified values are determined according to free field measurements of sound levels in dB(A) at a distance of 3 m.

Sound power Lw(A) spectrum in dB(A) via frequency band in Hz.

Model	63	125	250	500	1000	2000	4000	8000	Model	63	125	250	500	1000	2000	4000	8000
100	7	23	16	33	45	44	37	26	250	14	21	29	36	39	37	38	38
125	8	17	18	34	43	41	33	22	315	12	20	29	36	36	39	38	35
150	10	19	38	40	49	41	40	24	355	12	17	29	37	39	40	39	38
200	11	13	21	35	41	36	46	38									

Dimensions in mm

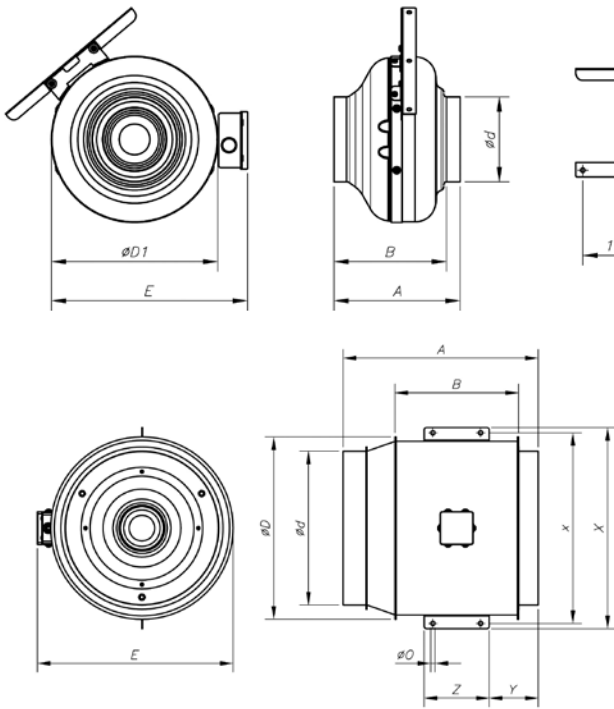

Model	A	B	ød	øD	E
CA/LINE-100	206	167	100	245	287
CA/LINE-125	206	175	125	245	287
CA/LINE-150	227	176	150	345	389
CA/LINE-200	227	175	200	345	389
CA/LINE-250	230	170	250	345	389
CA/LINE-315	257	189	315	402	446

Model	A	B	ød	øD	E	øO	x	X	Y	Z
CA/LINE-355	450	352	354	420	470	10	442	466	135	110

Characteristic Curves

Q = Airflow in m³/h, m³/s and cfm.

Pe = Static pressure in mm.w.c., Pa and in wg.

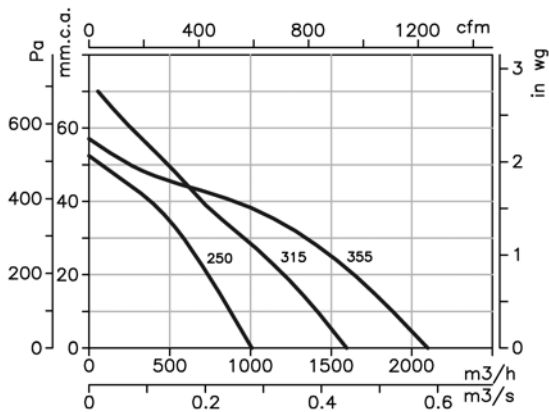
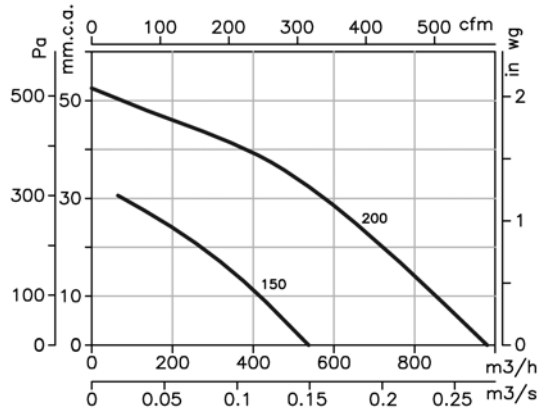
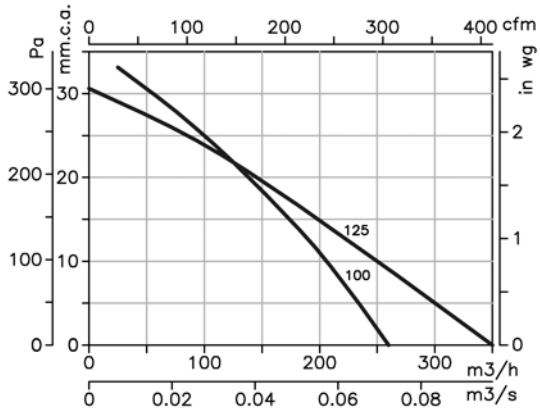

CL CL/PLUS

CL: Low-profile, in-line rectangular duct fans with inspection cover to aid cleaning

CL/PLUS: In-line rectangular duct fans with 50mm insulation.

Fan:

- Galvanized sheet steel casing
- Impeller with forward-facing blades made from galvanised sheet steel
- External connection box, IP-55 protection, V0 flame-retardant

Motor:

- Single-phase two-speed motors with IE-2 efficiency, except lower powers 0.75 kW
- Class F external rotor motors with ball bearings, IP-54 protection
- Single-phase 230 50Hz., and three-phase 230/400V. 50Hz.
- Working temperature: -20°C +50°C

Finish:

- Anticorrosive galvanized sheet steel.



CL



CL/PLUS

Order code

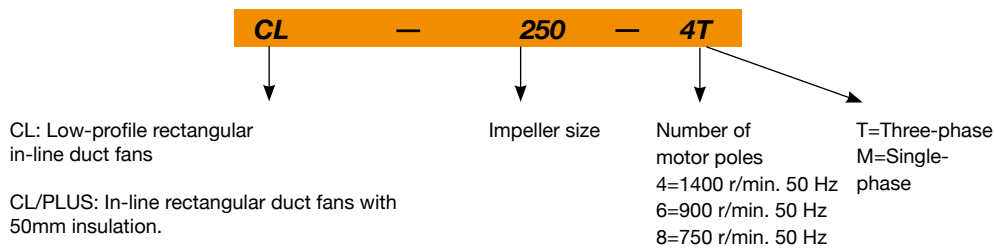

Technical characteristics

Model	Speed (r/min)	Maximum admissible current (A)		Installed Power (kW)	Maximum Airflow (m³/h)	Irradiated sound pressure level at 2/3 of Qmax dB(A) (1)	Approx. weight (Kg)
		230V	400V				
CL-200-4T	1270	0.94	0.54	0.12	1150	52	11
CL-200-4M	1150	0.68		0.08	860	51	11
CL-225-4T	1210	1.42	0.82	0.30	1700	53	17
CL-225-4M	1260	1.90		0.24	1670	53	18
CL-225-6T	720	0.73	0.42	0.08	1070	45	16
CL-225-6M	810	0.75		0.08	1080	45	16
CL-250-4T	1290	2.56	1.48	0.55	2650	55	21
CL-250-4M	1340	3.10		0.50	2350	54	23
CL-250-6T	875	1.11	0.64	0.15	1630	49	19
CL-250-6M	900	1.30		0.15	1500	48	21
CL-280-4T	1330	4.05	2.34	0.85	3100	60	30
CL-280-6T	820	1.42	0.82	0.20	2010	52	27
CL-280-6M	710	2.10		0.24	2120	53	28
CL-315-4T	1380	7.01	4.05	1.80	4160	65	44
CL-315-6T	850	2.46	1.42	0.37	2820	54	34
CL-315-6M	860	3.15		0.37	2780	54	34
CL-355-6T	840	4.54	2.62	0.85	4200	58	46
CL-355-6M	890	6.20		0.80	4070	58	53
CL-355-8T	620	2.15	1.24	0.37	3030	50	43
CL-400-6T	880	7.88	4.55	1.70	7120	63	71
CL-400-8T	620	3.67	2.12	0.70	5020	55	66
CL-450-6T	880	12.47	7.20	2.90	8900	64	94
CL-450-8T	680	7.38	4.26	1.30	7440	58	85

(1) The irradiated sound pressure levels dB(A) are free field measurements at 1 metre.

Technical characteristics

Model	Speed (r/min)	Maximum admissible current (A)		Absorbed Power (kW)	Maximum Airflow (m³/h)	Sound pressure level at 1/3 of Qmax dB(A) (1)	Approx. weight (Kg)
		230V	400V				
CL/PLUS-200-4M	1180	1,80		0,36	1100	36,0	21
CL/PLUS-225-4M	1250	2,30		0,51	1650	38,0	23
CL/PLUS-250-4M	1190	3,00		0,69	1900	42,0	28
CL/PLUS-280-4M	1210	5,10		1,15	2900	47,0	37
CL/PLUS-315-4T	1300		4,10	2,50	5050	52,0	47
CL/PLUS-355-4T	1320		6,00	3,70	6300	58,0	78
CL/PLUS-400-4T	1330		8,10	5,00	7100	61,0	99
CL/PLUS-400-6T	830		4,90	2,70	7050	50,8	59
CL/PLUS-450-4T	1330		8,10	5,00	7200	62,0	111
CL/PLUS-450-6T	830		4,90	2,70	7800	51,8	60

(1) The sound pressure levels dB(A) are free field measurements at 1 metres.

Acoustic features

Sound power Lw(A) spectrum in dB(A) via frequency band in Hz.

Model	63	125	250	500	1000	2000	4000	8000	Model	63	125	250	500	1000	2000	4000	8000
200-4	44	49	52	53	55	52	48	42	CL/PLUS-200-4M	20	22	31	37	40	37	35	35
225-4	45	50	53	54	56	53	49	43	CL/PLUS-225-4M	29	27	33	43	44	38	42	40
225-6	38	43	46	47	47	44	40	34	CL/PLUS-250-4M	34	33	37	43	44	39	39	35
250-4	47	52	55	56	58	55	51	45	CL/PLUS-280-4M	44	37	41	44	48	44	41	40
250-6	42	47	50	51	51	48	44	38	CL/PLUS-315-4T	36	41	40	47	53	48	48	47
280-4	52	57	60	61	63	60	56	50	CL/PLUS-355-4T	41	41	49	55	58	54	52	51
280-6	45	50	53	54	54	51	47	41	CL/PLUS-400-4T	47	48	50	56	63	56	53	53
315-4	57	62	65	66	68	65	61	55	CL/PLUS-400-6T	37	38	40	46	53	46	43	43
315-6	47	52	55	56	56	53	49	43	CL/PLUS-450-4T	45	49	51	59	63	56	53	53
355-6	51	56	59	60	60	57	53	47	CL/PLUS-450-6T	35	39	41	49	53	46	43	43
355-8	43	48	50	53	51	48	44	39									
400-6	56	61	64	65	65	62	58	52									
400-8	48	53	55	58	56	53	49	44									
450-6	57	62	65	66	66	63	59	53									
450-8	51	56	58	61	59	56	52	47									

Dimensions in mm

CL

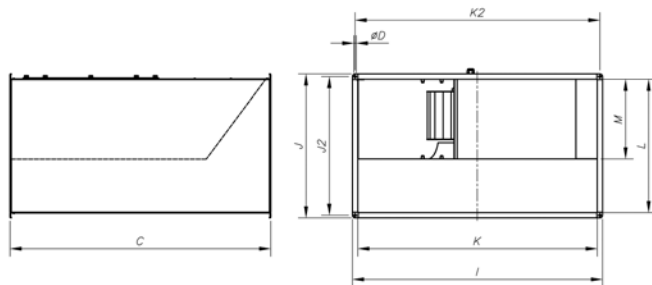

Model	C	øD	I	J	J2	K	k2	L	M
CL-200	450	ø9	440	240	220	400	420	200	115
CL-225	530	ø9	540	290	270	500	520	250	142
CL-250	560	ø9	540	340	320	500	520	300	155
CL-280	640	ø9	640	340	320	600	620	300	165
CL-315	700	ø9	640	390	370	600	620	350	175
CL-355	780	ø9	470	440	420	700	720	400	202
CL-400	880	ø9	840	540	520	800	820	500	285
CL-450	980	ø9	1040	540	520	1000	1020	500	300

CL/PLUS

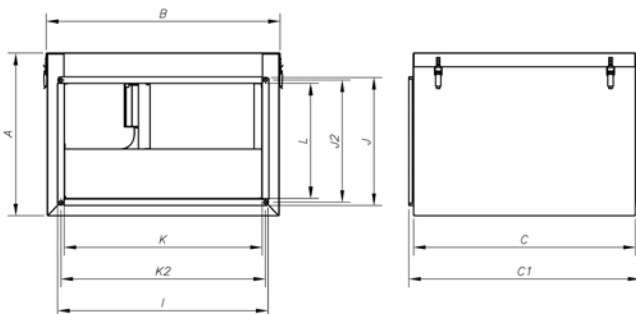

Model	A	B	C	C1	I	J	J2	K	K2	L
CL/PLUS-200	338	507	417	445	440	240	220	400	420	200
CL/PLUS-225	393	605	502	530	540	290	270	500	520	250
CL/PLUS-250	443	605	532	560	540	340	320	500	520	300
CL/PLUS-280	443	705	612	640	640	340	320	600	620	300
CL/PLUS-315	493	705	672	700	640	390	370	600	620	350
CL/PLUS-355	562	811	752	780	740	440	420	700	720	400
CL/PLUS-400	662	911	852	880	840	540	520	800	820	500
CL/PLUS-450	662	1110	952	980	1040	540	520	1000	1020	600

Characteristic Curves

Q = Airflow in m³/h and m³/s

Pe= Static pressure in mm.w.c. and Pa

The radiated sound levels given on the curves are free field pressure measurements at 1 metres.

CL

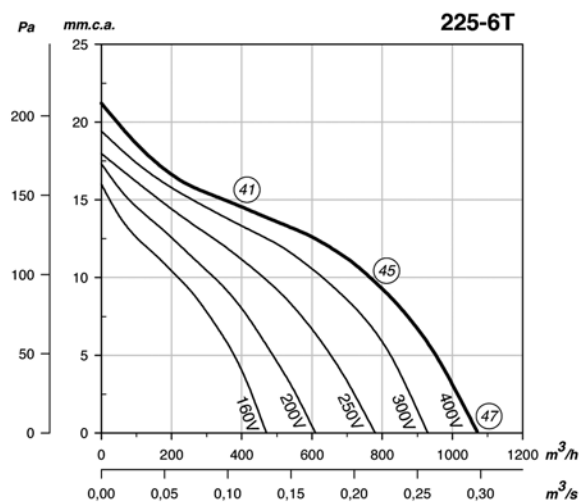
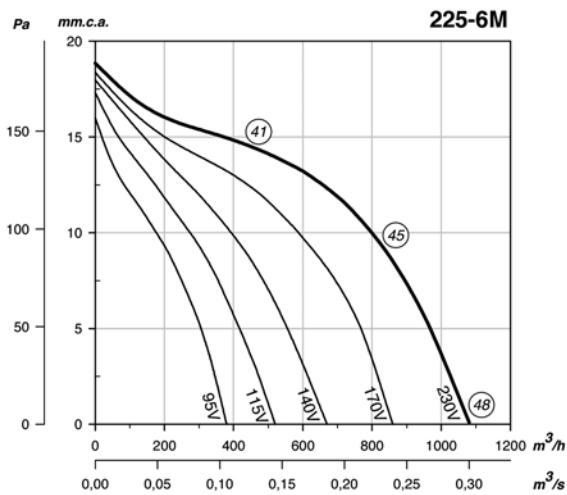
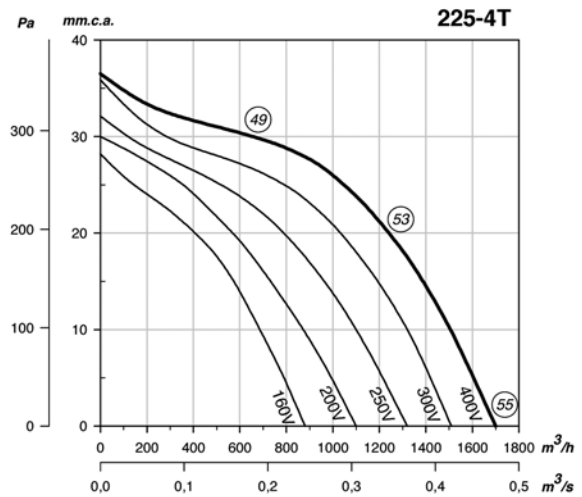
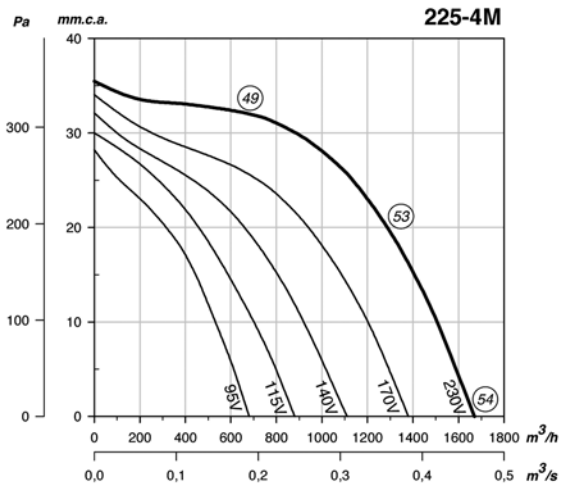
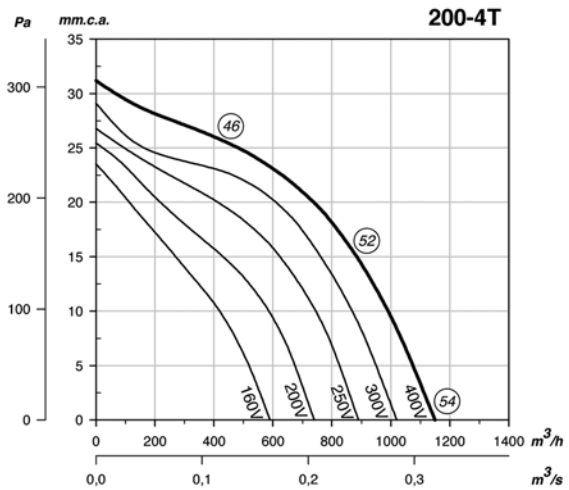
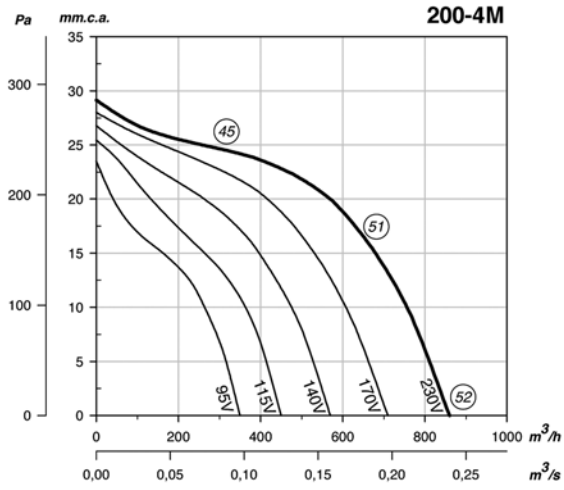

Characteristic Curves

Q = Airflow in m³/h and m³/s

Pe = Static pressure in mm.w.c. and Pa

The radiated sound levels given on the curves are free field pressure measurements at 1 metres.

CL

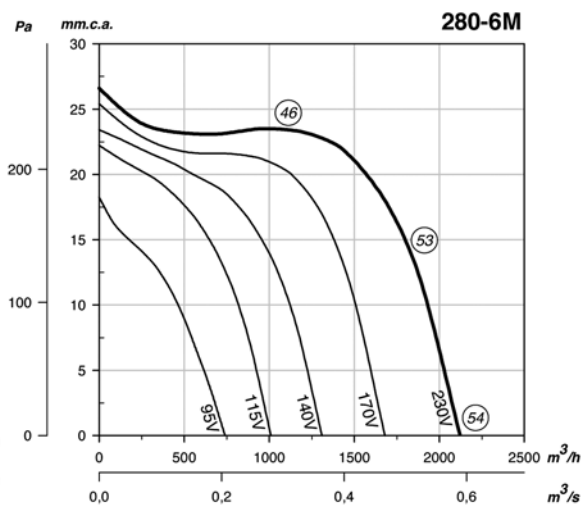
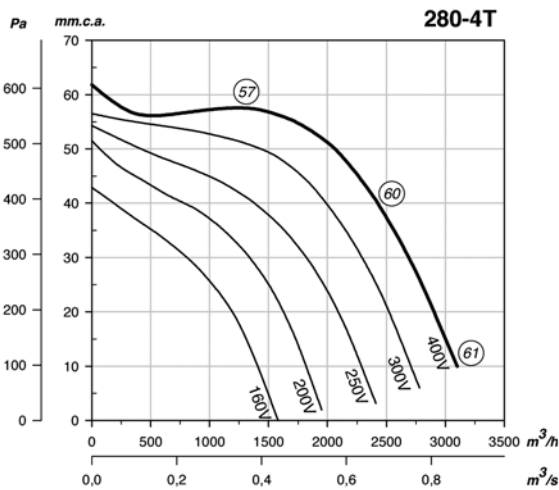
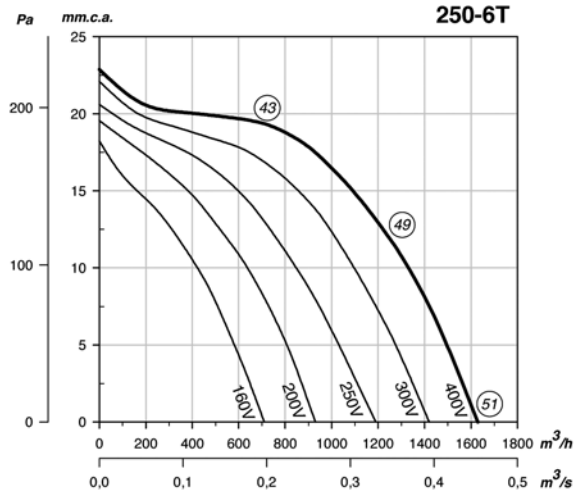
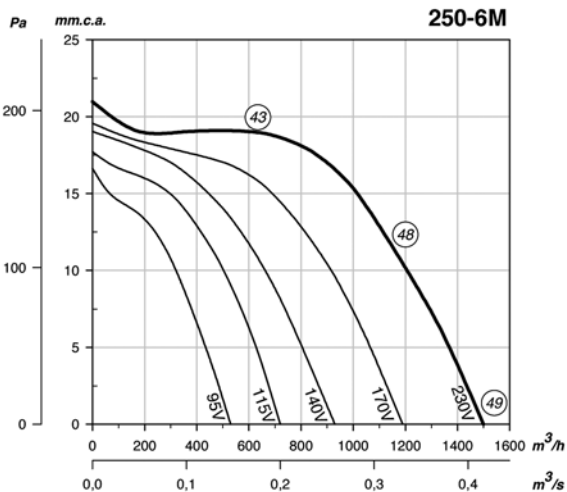
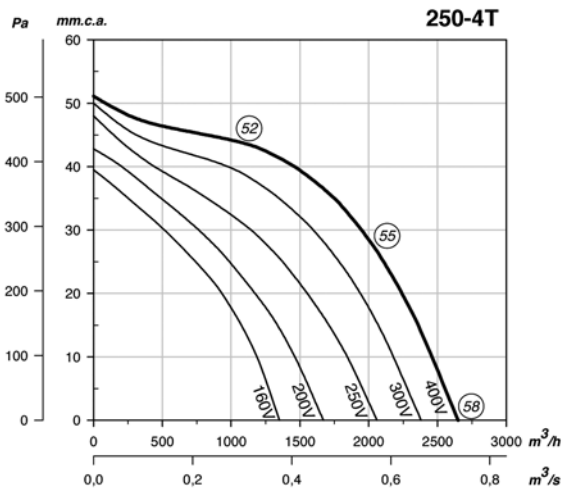
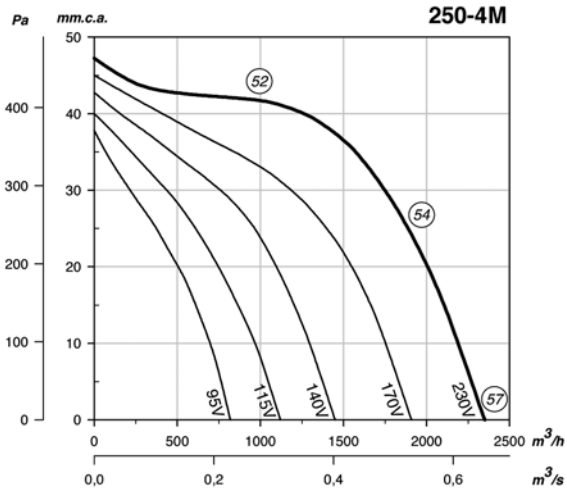

Characteristic Curves

Q = Airflow in m³/h and m³/s Pe= Static pressure in mm.w.c. and Pa
 The radiated sound levels given on the curves are free field pressure measurements at 1 metres.

CL

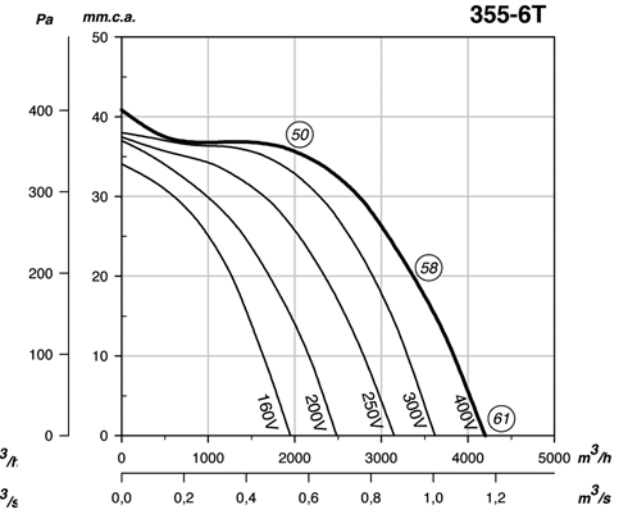
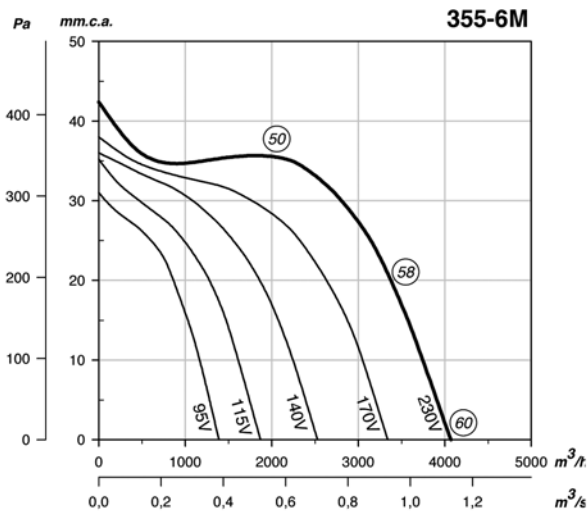
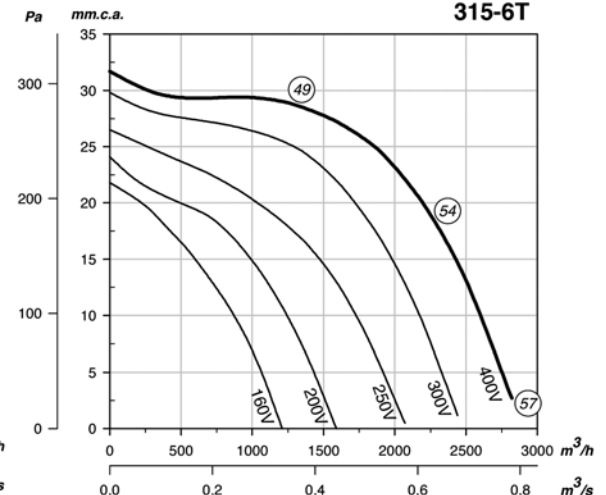
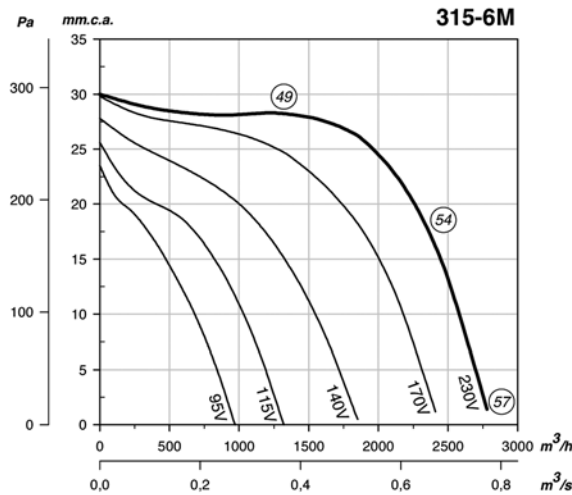
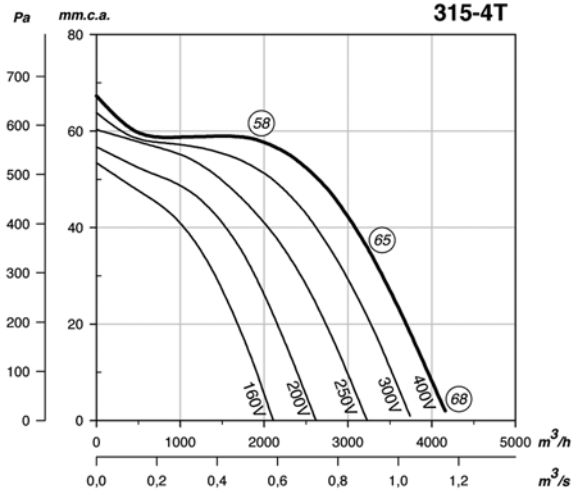
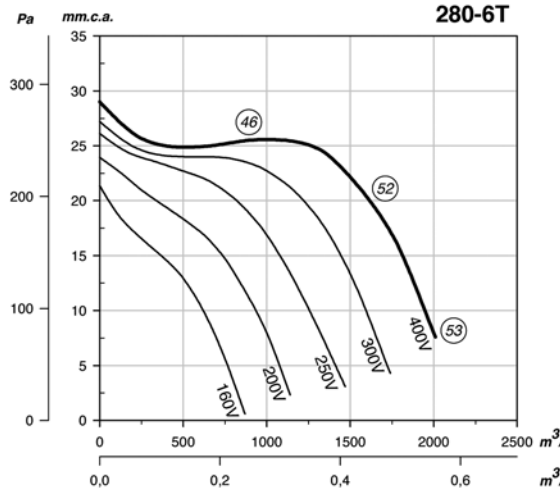

Characteristic Curves

Q = Airflow in m³/h and m³/s

Pe = Static pressure in mm.w.c. and Pa

The radiated sound levels given on the curves are free field pressure measurements at 1 metres.

CL

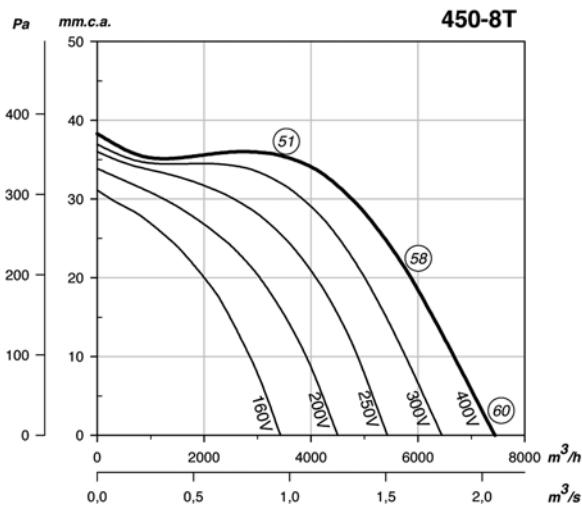
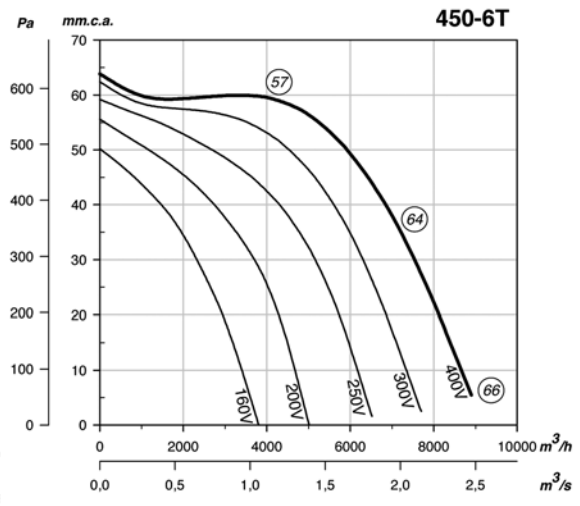
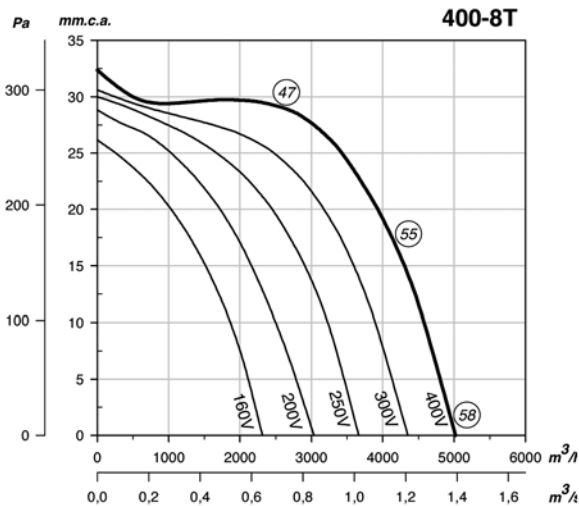
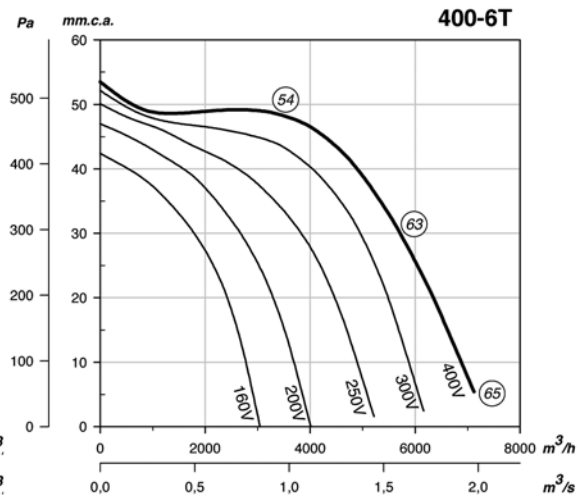
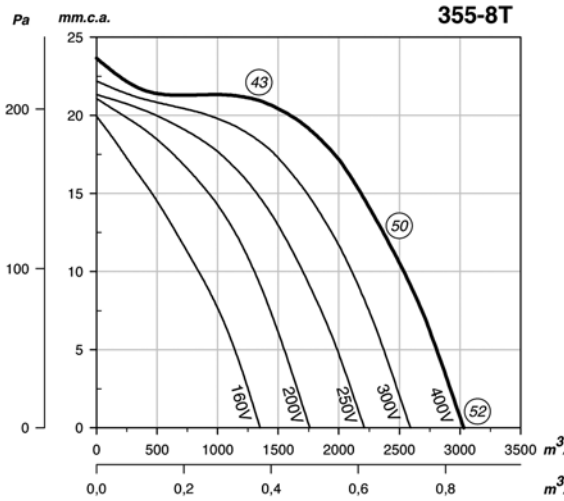

Characteristic Curves

Q = Airflow in m³/h and m³/s

Pe= Static pressure in mm.w.c. and Pa

CL/PLUS

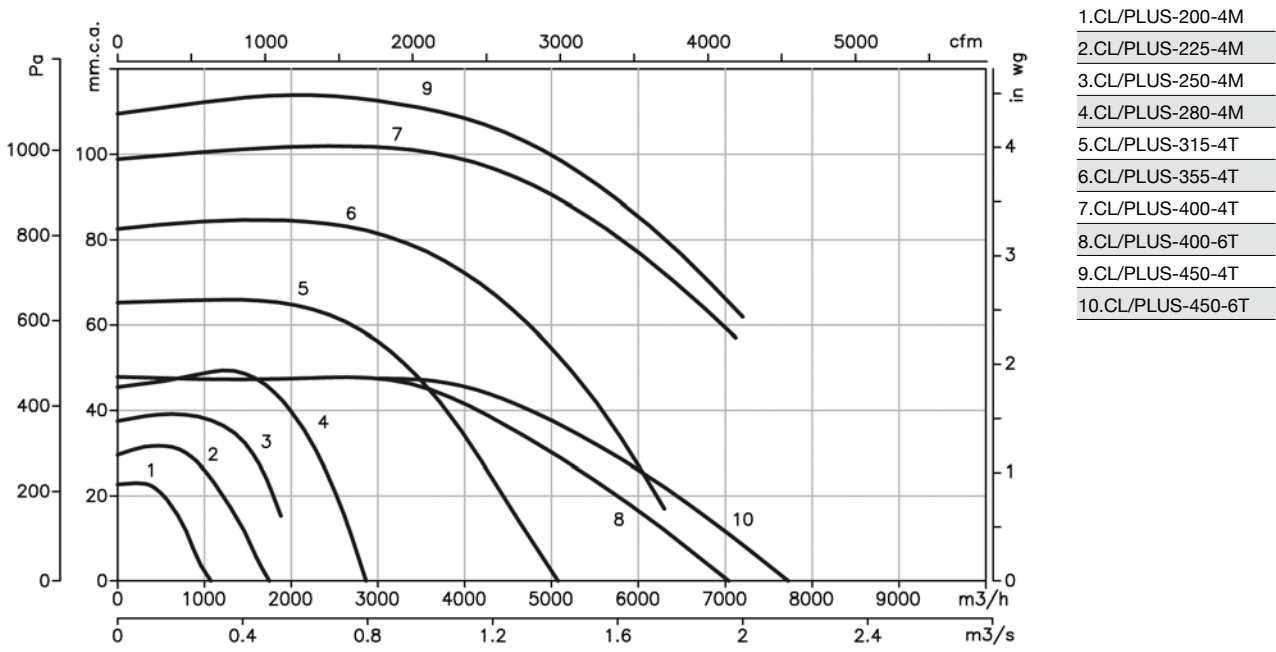

Accessories

See the accessories section.

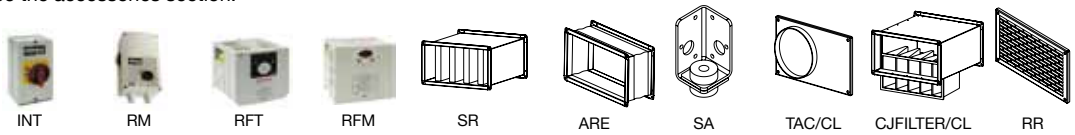

TUB

In-line fans with removable units and small size for high temperatures (250°C) designed to work interleaved in chimney ducts



Fan:

- Steel sheet casing
- Impeller with blades made from galvanised sheet steel
- Closing which makes it possible to extract the body easily and quickly
- External terminal board

Motor:

- Motor with Long Life ball bearings, IPX4 protection
- Single-phase 220-240V. 50Hz
- Working temperature: -10°C +250°C

Finish:

- Anticorrosive in heat-resistant paint

Order code

TUB — 200



TUB: In-line fans with removable bodies and small size for high temperatures (250°C)



Inlet diameter in mm

Technical characteristics

Model	Speed (r/min)	Maximum admissible current 220-240V (A)	Absorbed Power (W)	Maximum Airflow (m ³ /h)	Irradiated sound level (*) dB(A)	Approx. weight (Kg)
TUB-200	2780	0.30	68	250	39	7
TUB-225	2765	0.32	75	330	41	8
TUB-250	2760	0.35	80	400	43	9
TUB-315	2600	0.85	180	830	48	13

(*) The radiated sound pressure levels are free field measurements at 3 metres with rigid tubes during inlet and outlet.

Dimensions in mm

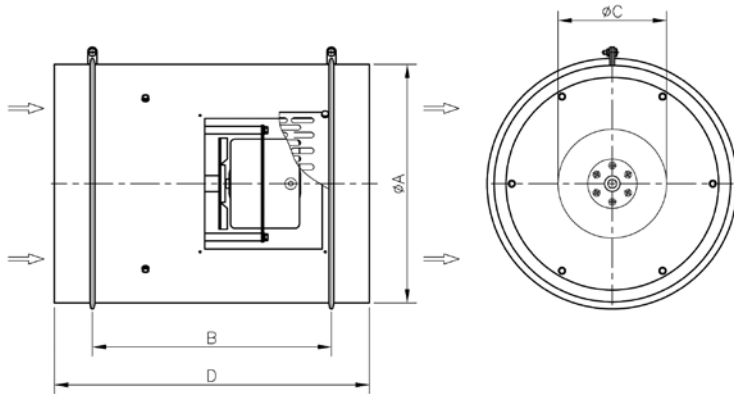

Model	ϕA	B	ϕC	D
TUB-200	200	255	116.5	355
TUB-225	225	255	116.5	355
TUB-250	250	255	116.5	355
TUB-315	315	315	142.5	415

Characteristic Curves

Q = Airflow in m³/h, m³/s and cfm.

Pe = Static pressure in mm.w.c., Pa and in wg.

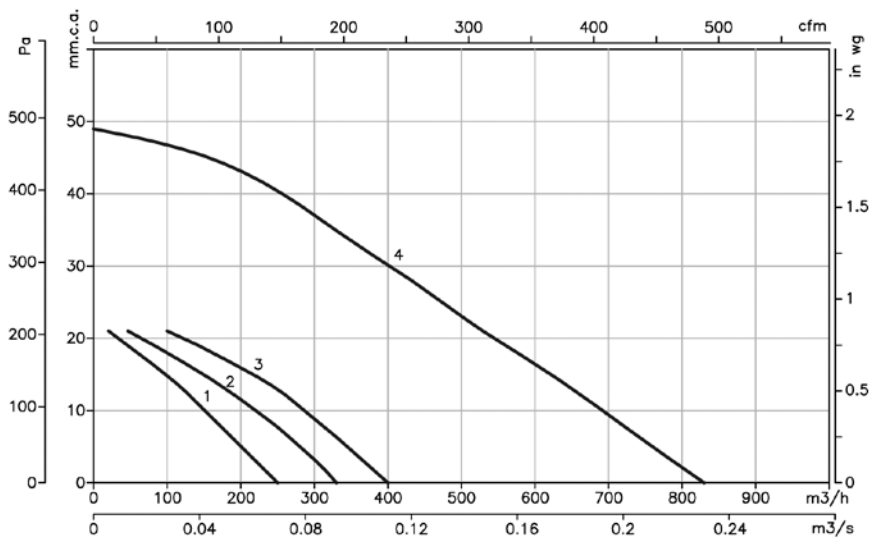

- 1: TUB-200
- 2: TUB-225
- 3: TUB-250
- 4: TUB-315

Accessories

See the accessories section.



STUB

CBD CBD 3V



High-quality, robust impeller, dynamically balanced in accordance with ISO-1940

Centrifugal double-inlet fans with direct motor and impeller with forward-facing blades

DTM 3V: Centrifugal double-inlet fans with three-speed motor

Fan:

- Galvanized sheet steel casing
- Impeller with forward-facing blades made from galvanised sheet steel
- PSB base stands can be supplied

Motor:

- Class F closed motors with incorporated thermal protector, ball bearings and IP-54 protection
- Single-phase 220-240V.-50Hz. and three-phase 220-240/380-415V.-50Hz.
- Max. air temperature to transport: -20°C.+ 60°C.

Finish:

- Anticorrosive galvanized sheet steel.

Order code

CBD	—	2525	—	4M	—	3/4	—	3V
CBD: Centrifugal double-inlet fans with direct motor and impeller with forward-facing blades		Impeller size in mm mm inches		Number of motor poles 4=1400 r/min. 50 Hz 6=900 r/min. 50 Hz		T=Three-phase M=Single-phase Power motor (c.v.)		With 3 speed motors
CDB 3V: Centrifugal double-inlet fans with three-speed motor		1919 7/7 2525 9/9 2828 10/10 3333 12/12 3939 15/15						

Technical characteristics

Model	Maximum Speed (r/min)	Equivalent in inches	Maximum admissible current (A)		Installed Power (kW)	Maximum Airflow (m³/h)	Sound level dB(A)	Approx. weight (Kg)
			230V	400V				
CBD-1919-4M 1/5	1230	7/7	1.75		0.15	1520	59	7.0
CBD-1919-6M 1/10	820	7/7	0.98		0.07	1230	53	7.0
CBD-2525-4M 1/2	1320	9/9	3.30		0.37	2800	66	13.2
CBD-2525-4M 3/4	1310	9/9	4.50		0.55	3600	70	14.0
CBD-2525-6M 1/5	850	9/9	1.50		0.15	2200	60	11.5
CBD-2525-6M 1/3	830	9/9	2.40		0.25	2700	62	12.7
CBD-2828-4M 1/2	1320	10/10	3.30		0.37	2800	65	15.7
CBD-2828-4M 3/4	1310	10/10	4.50		0.55	3950	70	16.5
CBD-2828-6M 1/3	830	10/10	2.40		0.25	3200	62	15.2
CBD-2828-6M 3/4	900	10/10	4.40		0.55	3600	64	21.0
CBD-3333-6T 1 1/2	900	12/12	6.60	3.80	1.10	7800	75	24.5
CBD-3333-6M 3/4	850	12/12	5.00		0.55	4900	64	23.0
CBD-3333-6M 1	850	12/12	6.30		0.75	6000	71	24.0
CBD-3939-6T 3	890	15/15	10.90	6.30	2.20	11900	75	39.0
CBD-1919-4M 1/5 3V	1230	7/7	1.75		0.15	1520	59	7
CBD-2525-4M 1/2 3V	1320	9/9	3.3		0.37	2800	66	13.2
CBD-2525-4M 3/4 3V	1310	9/9	4.5		0.55	3600	70	14
CBD-2525-6M 1/3 3V	830	9/9	2.4		0.25	2700	62	12.7
CBD-2828-4M 1/2 3V	1320	10/10	3.3		0.37	2800	65	15.7
CBD-2828-4M 3/4 3V	1310	10/10	4.5		0.55	3950	70	16.5
CBD-2828-6M 1/3 3V	830	10/10	2.4		0.25	3200	62	15.2
CBD-2828-6M 3/4 3V	900	10/10	4.4		0.55	3600	64	21
CBD-3333-6M 3/4 3V	850	12/12	5		0.55	4900	64	23
CBD-3333-6M 1 3V	850	12/12	6.3		0.75	6000	71	24

Acoustic features

Sound power Lw(A) spectrum in dB(A) via frequency band in Hz. Maximum speed

Model	63	125	250	500	1000	2000	4000	8000	Model	63	125	250	500	1000	2000	4000	8000
CBD-1919-4M 1/5	29	44	55	63	65	64	63	55	CBD-1919-4M 1/5 3V	29	44	55	63	65	64	63	55
CBD-1919-6M 1/10	23	38	49	57	59	58	57	49	CBD-2525-4M 1/2 3V	36	51	62	70	72	71	70	62
CBD-2525-4M 1/2	36	51	62	70	72	71	70	62	CBD-2525-4M 3/4 3V	40	55	66	74	76	75	74	66
CBD-2525-4M 3/4	40	55	66	74	76	75	74	66	CBD-2525-6M 1/3 3V	32	47	58	66	68	67	66	58
CBD-2525-6M 1/5	30	45	56	64	66	65	64	56	CBD-2828-4M 1/2 3V	35	50	61	69	71	70	69	61
CBD-2525-6M 1/3	32	47	58	66	68	67	66	58	CBD-2828-4M 3/4 3V	40	55	66	74	76	75	74	66
CBD-2828-4M 1/2	35	50	61	69	71	70	69	61	CBD-2828-6M 1/3 3V	32	47	58	66	68	67	66	58
CBD-2828-4M 3/4	40	55	66	74	76	75	74	66	CBD-2828-6M 3/4 3V	34	48	60	68	70	69	67	60
CBD-2828-6M 1/3	32	47	58	66	68	67	66	58	CBD-3333-6M 3/4 3V	34	49	60	68	70	69	68	60
CBD-2828-6M 3/4	34	48	60	68	70	69	67	60	CBD-3333-6M 1 3V	41	56	67	75	77	76	75	67
CBD-3333-6T 1 1/2	45	60	71	79	81	80	79	71									
CBD-3333-6M 3/4	34	49	60	68	70	69	68	60									
CBD-3333-6M 1	41	56	67	75	77	76	75	67									
CBD-3939-6T 3	48	62	74	81	84	83	81	73									

Dimensions in mm

CBD- 1919...3333

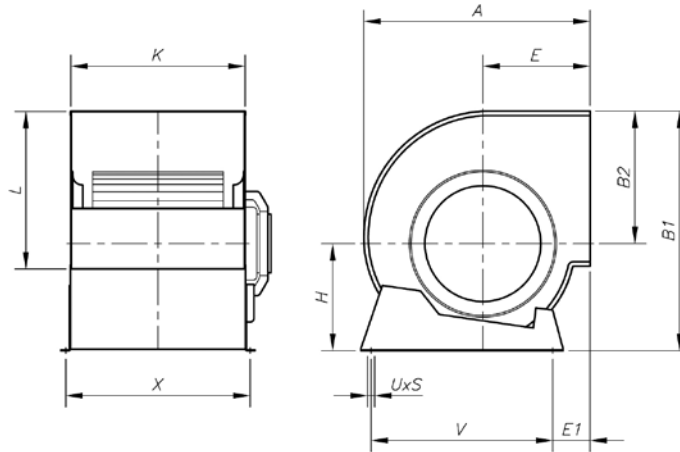

CBD- 3939

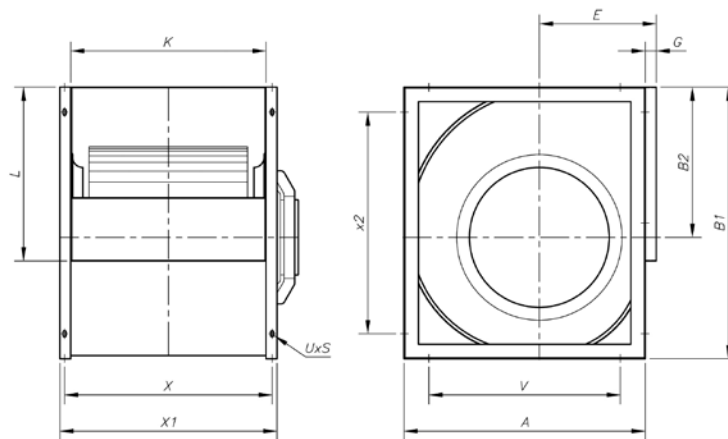

Model	Equiv. in Inches	A	B1	B2	E	E1	G	H	K	L	UxS	V	X	x1	x2
CBD-1919	7/7	315	333	189	152	64	-	144	230	208	9x13	225	258	-	-
CBD-2525	9/9	380	400	218	183	78	-	182	300	263	9x13	275	328	-	-
CBD-2828	10/10	422	450	246	202	73	-	204	326	292	9x17	315	355	-	-
CBD-3333	12/12	493	526	290	230	82	-	236	387	345	9x17	390	415	-	-
CBD-3939	15/15	553	632	348	265	-	30	-	473	404	9x17	406	500	533	406

Characteristic Curves

Q = Airflow in m³/h, m³/s and cfm.

Pe= Static pressure in mm.w.c., Pa and in wg.

CBD

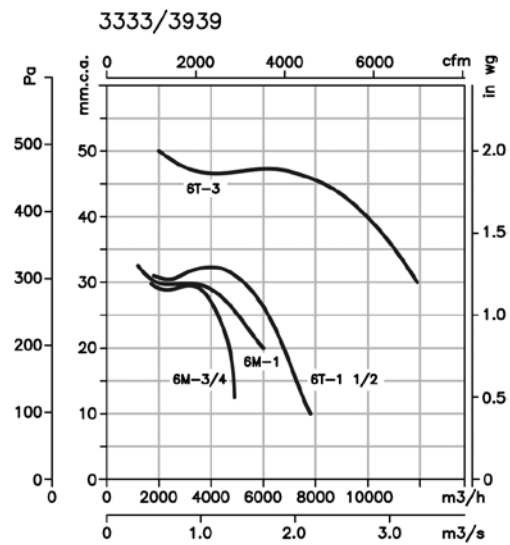
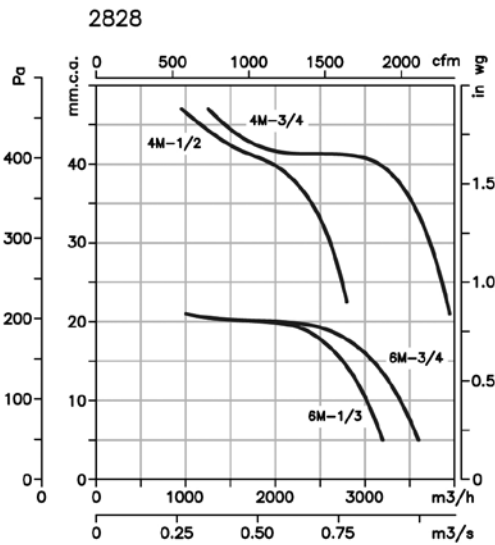
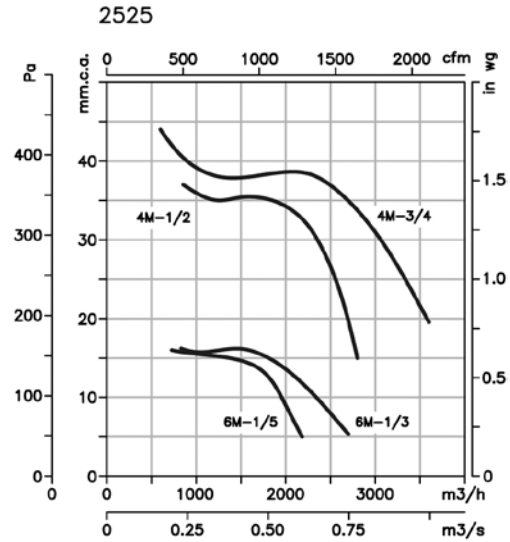
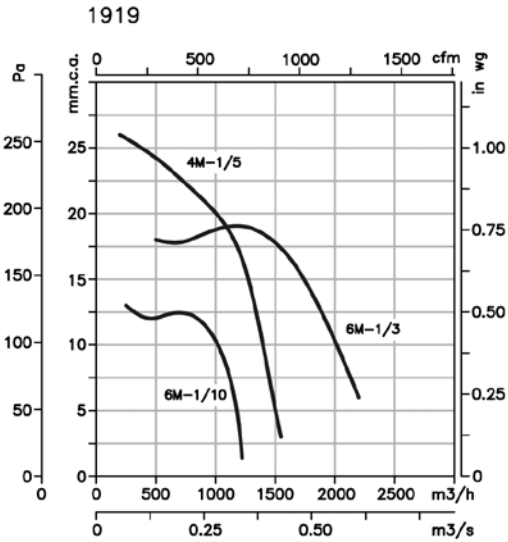

Characteristic Curves

Q = Airflow in m³/h, m³/s and cfm.

Pe = Static pressure in mm.w.c., Pa and in wg.

CBD 3V

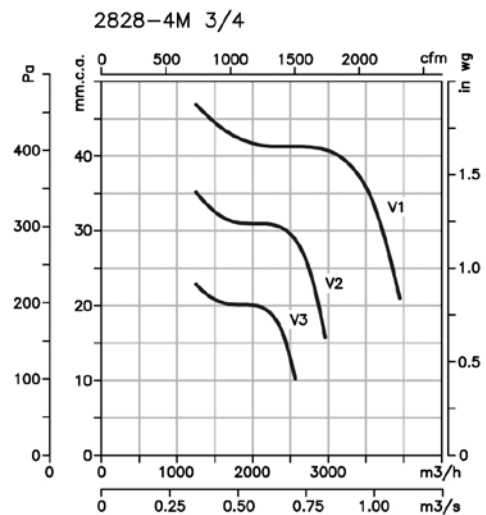
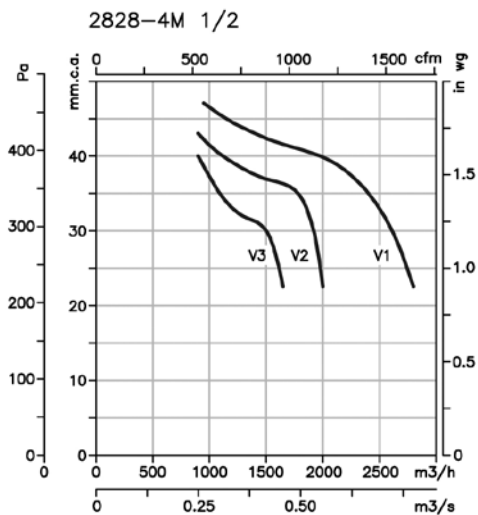
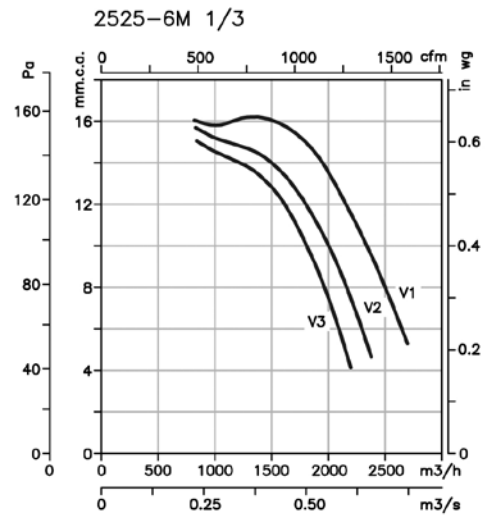
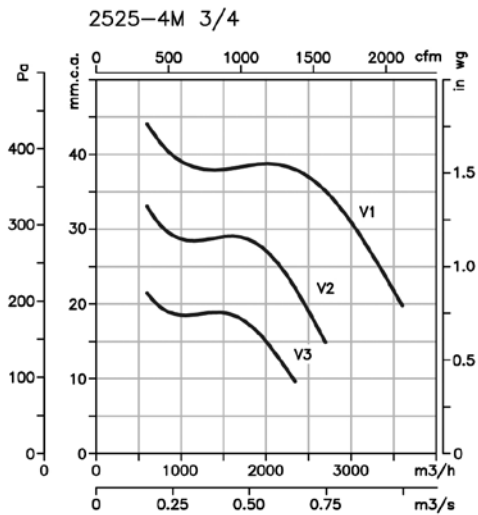
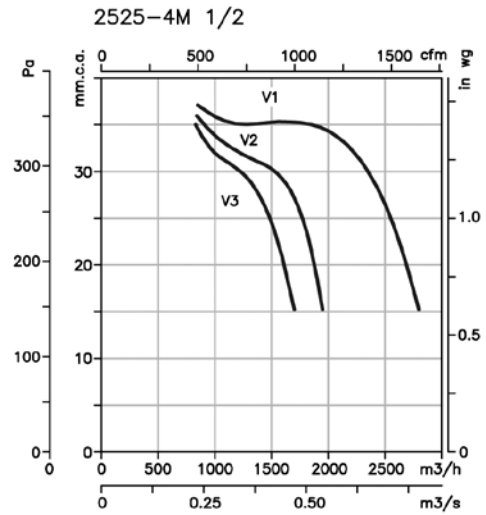
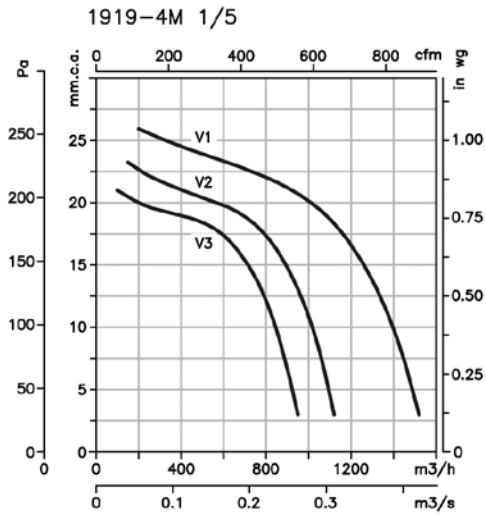

Characteristic Curves

Q = Airflow in m³/h, m³/s and cfm.

Pe= Static pressure in mm.w.c., Pa and in wg.

CBD 3V

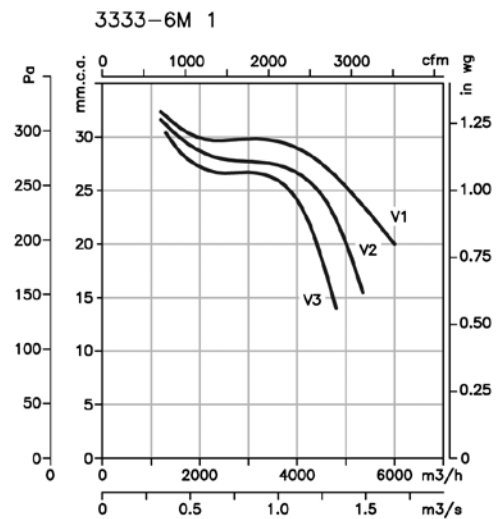
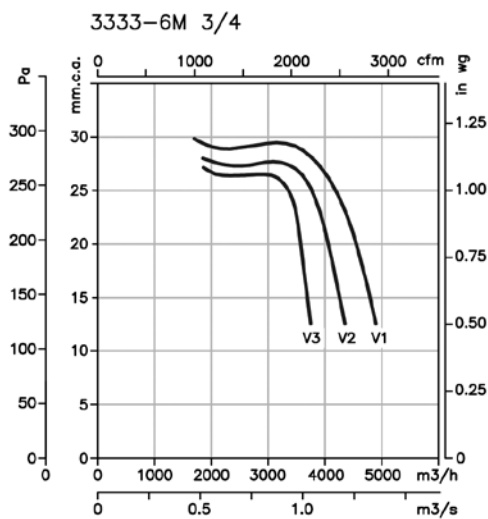
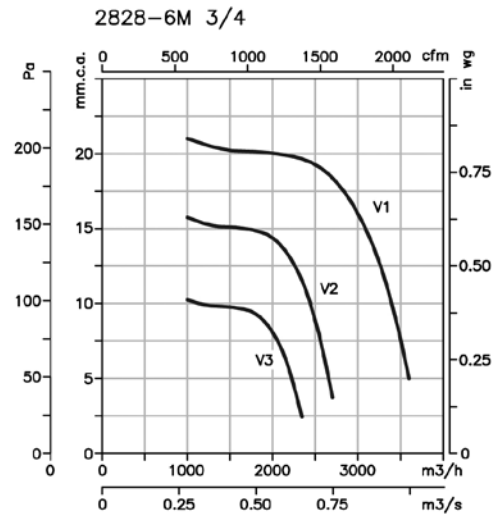
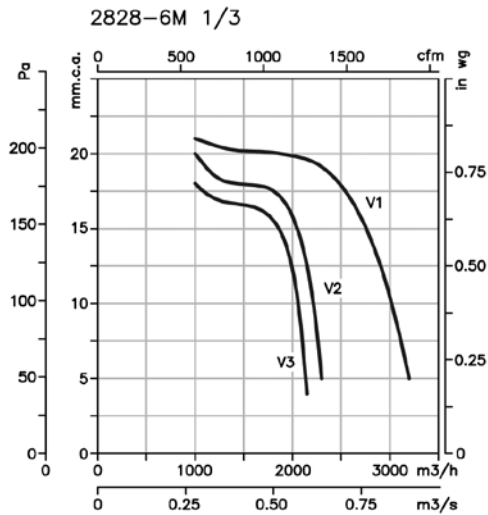

Accessories

See the accessories section.



CJBD CJBD/AL

CJBD: Soundproof ventilation units fitted with double-inlet fans, CBD series

CJBD/AL: Soundproof ventilation units with aluminium profiles fitted with double-inlet fans, CBD series



CJBD



CJBD/AL

Fan:

- Galvanised sheet steel structure with thermal insulation and soundproofing.
- Impeller with forward-facing blades made from galvanised sheet steel
- Stuffing-box for cable input
- CJBD/AL: with aluminium profiles

Motor:

- Class F closed motors with incorporated thermal protector, ball bearings and IP-54 protection
- Single-phase 220-240V.-50Hz. and three-phase 220-240/380-415V.-50Hz.
- Max. air temperature to transport: -20°C.+ 60°C.

Finish:

- Anticorrosive galvanized sheet steel.

On request:

- With circular inlet



CJBD: Includes base stand to aid installation

Order code

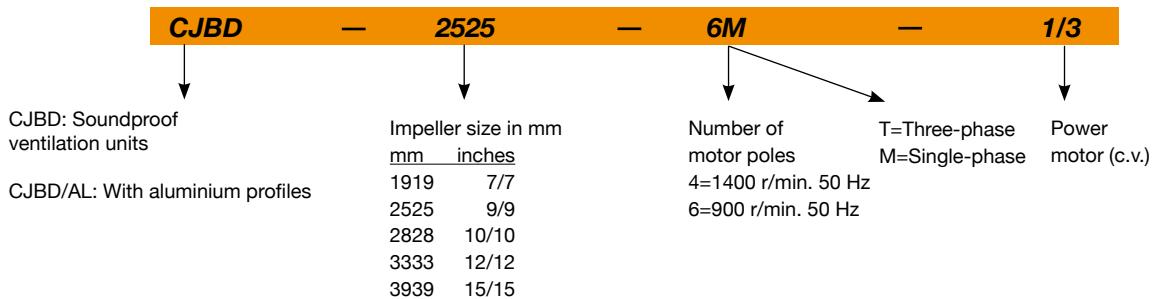

Technical characteristics

Model		Speed (r/min)	Equiv. in Inches	Maximum admissible current (A)		Installed Power (kW)	Maximum Airflow (m³/h)	Sound pressure level dB(A)	Approx. weight (Kg)	
				230V	400V				CJBD	CJBD/AL
CJBD	CJBD/AL 1919-4M 1/5	1230	7/7	1.75		0.15	1520	58	19.4	22.5
CJBD	CJBD/AL 1919-6M 1/10	820	7/7	0.98		0.07	1230	53	19.4	22.5
CJBD	CJBD/AL 2525-4M 1/2	1320	9/9	3.30		0.37	2800	66	28.1	31.8
CJBD	CJBD/AL 2525-4M 3/4	1310	9/9	4.50		0.55	3600	70	28.9	32.6
CJBD	CJBD/AL 2525-6M 1/5	850	9/9	1.50		0.15	2200	59	26.4	30.1
CJBD	CJBD/AL 2525-6M 1/3	830	9/9	2.40		0.25	2700	61	27.6	31.3
CJBD	CJBD/AL 2828-4M 1/2	1320	10/10	3.30		0.37	2800	65	33.0	37.3
CJBD	CJBD/AL 2828-4M 3/4	1310	10/10	4.50		0.55	3950	70	33.8	38.1
CJBD	CJBD/AL 2828-6M 1/3	830	10/10	2.40		0.25	3200	61	32.5	36.8
CJBD	CJBD/AL 3333-6T 1 1/2	900	12/12	6.60	3.80	1.10	7800	74	47.9	53.8
CJBD	CJBD/AL 3333-6M 3/4	850	12/12	5.00		0.55	4900	63	46.4	52.3
CJBD	CJBD/AL 3333-6M 1	850	12/12	6.30		0.75	6000	70	47.4	53.3
CJBD	CJBD/AL 3939-6T 3	890	15/15	10.90	6.30	2.20	11900	74	71.8	80.0

Acoustic features

Sound power Lw(A) spectrum in dB(A) via frequency band in Hz.

Model	63	125	250	500	1000	2000	4000	8000	Model	63	125	250	500	1000	2000	4000	8000
CJBD-1919-4M 1/5	43	54	58	62	64	63	62	53	CJBD-2828-4M 3/4	55	66	70	74	76	75	74	65
CJBD-1919-6M 1/10	38	49	53	57	59	58	57	48	CJBD-2828-6M 1/3	46	57	61	65	67	66	65	56
CJBD-2525-4M 1/2	51	62	66	70	72	71	70	61	CJBD-3333-6T 1 1/2	59	70	74	78	80	79	78	69
CJBD-2525-4M 3/4	55	66	70	74	76	75	74	65	CJBD-3333-6M 3/4	48	59	63	67	69	68	67	58
CJBD-2525-6M 1/5	44	55	59	63	65	64	63	54	CJBD-3333-6M 1	55	66	70	74	76	75	74	65
CJBD-2525-6M 1/3	46	57	61	65	67	66	65	56	CJBD-3939-6T 3	61	72	77	81	83	81	80	71
CJBD-2828-4M 1/2	50	61	65	69	71	70	69	60									

Dimensions in mm

CJBD

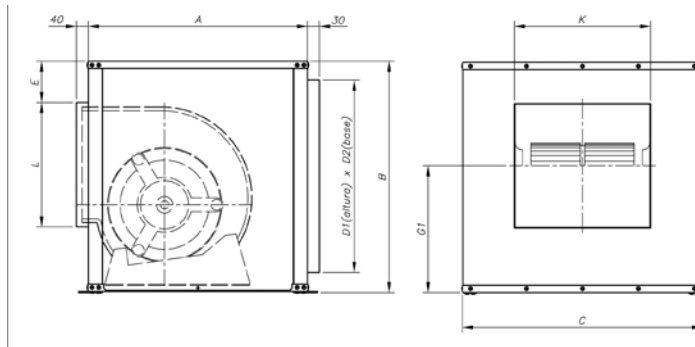

Model	Equiv. in Inches	A	B	C	E	D1xD2	G1	L	K
CJBD-1919	7/7	450	460	500	74	364x404	278	216	238
CJBD-2525	9/9	500	522	550	74	426x454	314	268	305
CJBD-2828	10/10	550	575	600	74	479x504	353	296	330
CJBD-3333	12/12	650	650	700	74	554x604	413	346	390
CJBD-3939	15/15	800	755	800	74	659x704	475,5	411	482

CJBD/AL

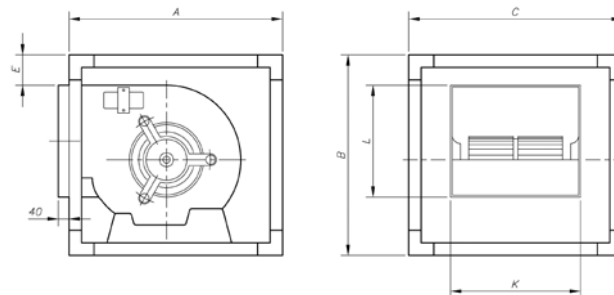

Model	Equiv. in Inches	A	B	C	E	L	K
CJBD/AL-1919	7/7	460	460	460	75	216	238
CJBD/AL-2525	9/9	520	520	520	75	268	305
CJBD/AL-2828	10/10	575	575	575	75	296	330
CJBD/AL-3333	12/12	650	650	650	75	346	390
CJBD/AL-3939	15/15	755	755	755	85	411	482

Characteristic Curves

See characteristic curves, CBD series.

Accessories

See the accessories section.



CBX CBXC CBXR CBXT

CBX: Double-inlet, belt-driven centrifugal fans with axis outlet on both sides and impeller with forward-facing blades

CBXC: Double-inlet, belt-driven centrifugal fans with rigid cube structure to reinforce the casing

CBXR: Double-inlet, belt-driven centrifugal fans with reinforced structure and rigid bridge bearings supported on the structure

CBXT: Double-inlet, belt-driven centrifugal fans with electric motor, pulley, belt kit and standardised protectors and impeller with forward-facing blades



CBX

Fan:

- Galvanized sheet steel casing
- Impeller with forward-facing blades made from galvanised sheet steel
- CBX and CBXC: Bearing mounted with rubber vibration dampers
- CBX: They are supplied with CPS base stands

Motor:

- Motors with IE-2 efficiency, except for motors with lower powers than 0.75 kW, monophase motors or two-speed motors
- Free axis with permanently greased ball bearings at each end
- Max. air temperature to transport: CBX and CBXC: -20°C.+ 80°C. CBXR: -20°C.+ 110°C.

Finish:

- Anticorrosive galvanized sheet steel.

On request:

- CBX: Motor mounting bracket and SM belt tensing device can be supplied



CBXC



CBXR



CBXT

Order code

CBXC — 12/12



CBX: Centrifugal double-inlet fans with free axis outlet



Impeller size in inches

CBXC: Centrifugal double-inlet fans with cube structure

CBXR: Centrifugal double-inlet fans with reinforced structure

CBXT — 12/12 — 1.5



CBXT: Double-inlet, belt-driven centrifugal fans fitted with electric motor



Impeller size in inches



Power motor (c.v.)

Technical characteristics

Model	Max. Speed (r/min)	Equivalent Inches	Max. installed Power (kW)	Maximum Airflow (m³/h)	Air temperature (°C)		Approx. weight (Kg)
					min.	max.	
CBX-1919	2500	7/7	1.1	3700	-20	+80	5.0
CBX-2525	1800	9/9	2.2	6200	-20	+80	9.0
CBX-2828	1700	10/10	3.0	7500	-20	+80	10.5
CBX-3333	1400	12/12	3.0	9500	-20	+80	15.5
CBX-3939	1000	15/15	4.0	14400	-20	+80	24.0
CBX-4747	800	18/18	5.5	23500	-20	+80	33.5
CBXC-7/7	2700		1.5	4200	-20	+80	6.0
CBXC-9/9	2100		3.0	7000	-20	+80	11.5
CBXC-10/10	1900		4.0	8400	-20	+80	13.5
CBXC-12/12	1600		4.0	10500	-20	+80	18.5
CBXC-15/15	1100		5.5	16000	-20	+80	27.5
CBXC-18/18	900		7.5	26000	-20	+80	38.5
CBXR-15/15	1200		5.5	16000	-20	80	28.5
CBXR-18/18	1000		7.5	26000	-20	80	40.0
CBXR-20/20	1000		11.0	28000	-20	+110	84.0
CBXR-22/22	900		15.0	34000	-20	+110	94.0
CBXR-25/25	700		15.0	46000	-20	+110	113.0
CBXR-30/28	600		18.5	60000	-20	+110	145.0

Model	Speed (r/min)	Maximum admissible current (A)			Installed Power (kW)	Maximum Airflow (m³/h)	Air temperature (°C)		Approx. weight (Kg)	Assembly Installation
		230V	400V	690V			min.	max.		
CBXT-7/7-0.25	1090	1.1	0.64		0.18	1050	-20	+80	37.0	A
CBXT-7/7-0.33	1220	1.4	0.78		0.25	1100	-20	+80	37.8	A
CBXT-7/7-0.5	1420	1.8	1.05		0.37	1250	-20	+80	39.0	A
CBXT-7/7-0.75	1600	2.5	1.45		0.55	1450	-20	+80	41.0	A
CBXT-7/7-1	1790	3.3	1.90		0.75	1500	-20	+80	42.5	A
CBXT-9/9-0.25	825	1.1	0.64		0.18	1700	-20	+80	48.0	A
CBXT-9/9-0.33	920	1.4	0.78		0.25	1800	-20	+80	50.0	A
CBXT-9/9-0.5	1020	1.8	1.05		0.37	2200	-20	+80	51.5	A
CBXT-9/9-0.75	1050	2.5	1.45		0.55	2900	-20	+80	54.5	A
CBXT-9/9-1	1070	3.3	1.90		0.75	3200	-20	+80	56.0	A
CBXT-9/9-1.5	1260	4.5	2.59		1.10	3750	-20	+80	59.0	A
CBXT-10/10-0.5	845	1.8	1.05		0.37	2950	-20	+80	55.0	A
CBXT-10/10-0.75	845	2.5	1.45		0.55	3800	-20	+80	57.0	A
CBXT-10/10-1	960	3.3	1.90		0.75	4175	-20	+80	58.5	A
CBXT-10/10-1.5	1070	4.5	2.59		1.10	4800	-20	+80	61.3	A
CBXT-10/10-2	1140	6.0	3.45		1.50	5400	-20	+80	64.6	A
CBXT-12/12-0.5	595	1.8	1.05		0.37	4200	-20	+80	69.0	A
CBXT-12/12-0.75	675	2.5	1.45		0.55	4800	-20	+80	71.0	A
CBXT-12/12-1	765	3.3	1.90		0.75	5400	-20	+80	72.4	A
CBXT-12/12-1.5	855	4.5	2.59		1.10	5800	-20	+80	75.3	A
CBXT-12/12-2	965	6.0	3.45		1.50	6500	-20	+80	78.6	A
CBXT-12/12-3	1180	8.4	4.85		2.20	7400	-20	+80	87.0	A
CBXT-15/15-0.75	525	2.5	1.45		0.55	5900	-20	+80	85.0	B
CBXT-15/15-1	595	3.3	1.90		0.75	6500	-20	+80	86.4	B
CBXT-15/15-1.5	635	4.5	2.59		1.10	7500	-20	+80	89.3	B
CBXT-15/15-2	670	6.0	3.45		1.50	8200	-20	+80	92.6	B
CBXT-15/15-3	740	8.4	4.85		2.20	9500	-20	+80	101.0	B
CBXT-15/15-4	805	11.2	6.48		3.00	10600	-20	+80	103.0	B
CBXT-15/15-5.5	965	15.0	8.65		4.00	12000	-20	+80	108.0	B
CBXT-18/18-1.5	480	4.5	2.59		1.10	9000	-20	+80	122.0	B
CBXT-18/18-2	605	6.0	3.45		1.50	9250	-20	+80	125.3	B
CBXT-18/18-3	590	8.4	4.85		2.20	11500	-20	+80	133.7	B
CBXT-18/18-4	640	11.2	6.48		3.00	13200	-20	+80	135.7	B
CBXT-18/18-5.5	675	15.0	8.65		4.00	15000	-20	+80	141.0	B
CBXT-18/18-7.5	760		11.40	6.60	5.50	17000	-20	+80	154.5	B
CBXT-20/20-2	430	6.0	3.45		1.50	11500	-20	+80	222.0	B
CBXT-20/20-3	530	8.4	4.85		2.20	12800	-20	+80	230.5	B
CBXT-20/20-4	575	11.2	6.48		3.00	14200	-20	+80	232.5	B
CBXT-20/20-5.5	635	15.0	8.65		4.00	15500	-20	+80	237.5	B
CBXT-20/20-7.5	675		11.40	6.60	5.50	17500	-20	+80	251.5	B
CBXT-20/20-10	725		14.80	8.50	7.50	20000	-20	+80	266.5	B
CBXT-22/22-2	385	6.0	3.45		1.50	14000	-20	+80	250.0	B
CBXT-22/22-3	475	8.4	4.85		2.20	15000	-20	+80	257.0	B

Technical characteristics

Model	Speed (r/min)	Maximum admissible current (A)			Installed Power (kW)	Maximum Airflow (m³/h)	Air temperature (°C)		Approx. weight (Kg)	Assembly version
		230V	400V	690V			min.	max.		
CBXT-22/22-4	515	11.2	6.48		3.00	17000	-20	+80	261.0	B
CBXT-22/22-5.5	570	15.0	8.65		4.00	19000	-20	+80	265.0	B
CBXT-22/22-7.5	605		11.40	6.60	5.50	21500	-20	+80	279.0	B
CBXT-22/22-10	725		14.80	8.50	7.50	22000	-20	+80	290.0	B
CBXT-22/22-15	765		21.00	12.10	11.00	27000	-20	+80	316.0	B
CBXT-25/25-3	375	8.4	4.85		2.20	17000	-20	+80	297.0	B
CBXT-25/25-4	405	11.2	6.48		3.00	20500	-20	+80	299.0	B
CBXT-25/25-5.5	450	15.0	8.65		4.00	22000	-20	+80	304.0	B
CBXT-25/25-7.5	485		11.40	6.60	5.50	24500	-20	+80	318.0	B
CBXT-25/25-10	545		14.80	8.50	7.50	28000	-20	+80	329.0	B
CBXT-25/25-15	610		21.00	12.10	11.00	32000	-20	+80	349.0	B
CBXT-30/28-3	330	8.4	4.85		2.20	20000	-20	+80	380.0	B
CBXT-30/28-4	360	11.2	6.48		3.00	22000	-20	+80	382.0	B
CBXT-30/28-5.5	380	15.0	8.65		4.00	25000	-20	+80	387.0	B
CBXT-30/28-7.5	380		11.40	6.60	5.50	31500	-20	+80	402.0	B
CBXT-30/28-10	410		14.80	8.50	7.50	36000	-20	+80	415.0	B
CBXT-30/28-15	430		21.00	12.10	11.00	42000	-20	+80	426.0	B
CBXT-30/28-20	480		28.50	16.50	15.00	48000	-20	+80	449.0	B

Dimensions in mm

CBX

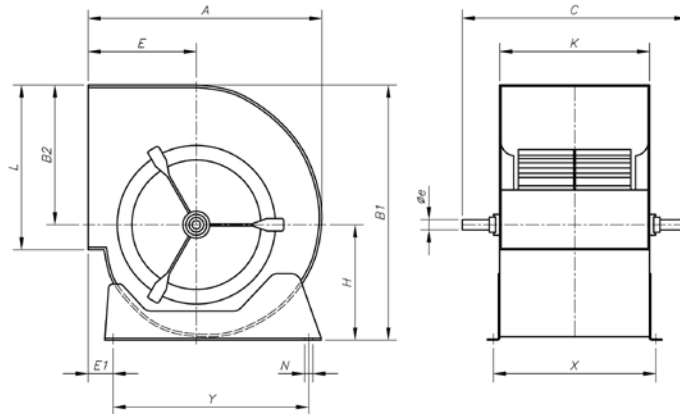

Model	Equiv. in inches	A	B1	B2	C	E	E1	H	K	L	N	øe	X	Y
CBX-1919	7/7	316	333	189	360	152	64	144	230	208	9x13	20	258	225
CBX-2525	9/9	380	400	218	430	183	78	182	300	263	9x13	20	328	275
CBX-2828	10/10	422	450	246	470	202	73	204	326	292	9x17	20	355	315
CBX-3333	12/12	493	526	290	560	230	82	236	387	345	9x17	25	415	390
CBX-3939	15/15	579	621	348	650	265	92	273	473	404	9x17	25	500	455
CBX-4747	18/18	686	746	415	750	323	82	331	540	482	9x17	25	568	575

CBXC

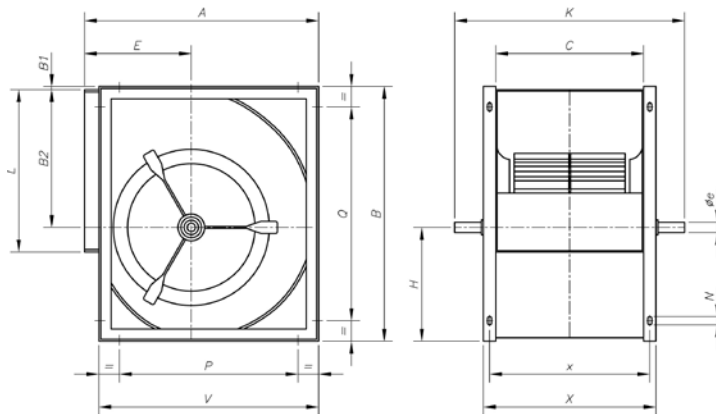

Model	A	B	B2	C	E	øe	H	K	L	N	P	Q	V	X	x
CBXC-7/7	322	342	189	230	152	20	153	360	208	9x17	148	175	292	290	262
CBXC-9/9	388	402	218	300	183	20	184	430	263	9x17	214	214	358	360	332
CBXC-10/10	428	450	246	326	202	20	204	470	292	9x17	254	254	398	386	358
CBXC-12/12	498	532	290	387	230	25	242	560	345	9x17	324	324	468	447	419
CBXC-15/15	583	632	348	473	265	25	284	650	404	9x17	406	406	553	533	505
CBXC-18/18	694	756	415	540	323	25	341	750	482	9x17	520	608	664	600	572

Dimensions in mm

CBXR

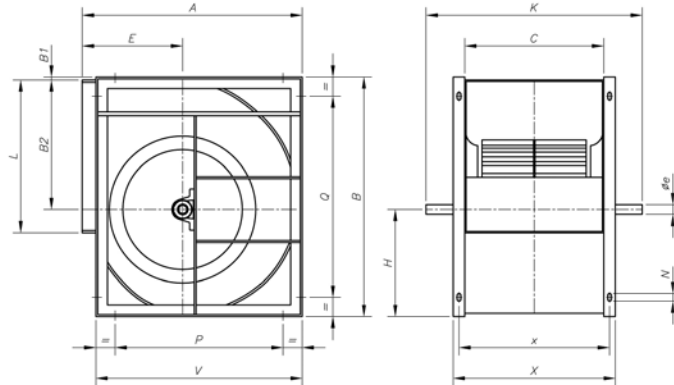

Model	A	B	B1	B2	C	E	øe	H	K	L	N	P	Q	V	X	x
CBXR-15/15	583	632	-	348	473	265	25	284	730	404	9x17	406	406	553	533	505
CBXR-18/18	694	756	-	415	540	323	25	341	800	482	9x17	520	608	664	600	572
CBXR-20/20	843	963	35	523	603	375	35	405	923	603	13x25	646	811	798	683	643
CBXR-22/22	913	1046	35	569	656	400	35	442	976	693	13x25	716	894	868	736	696
CBXR-25/25	998	1161	35	642	765	423	35	484	1085	793	13x25	801	1009	953	845	805
CBXR-30/28	1206	1400	35	776	888	515	40	589	1208	933	13x25	1009	1248	1161	968	928

CBXT Installation A

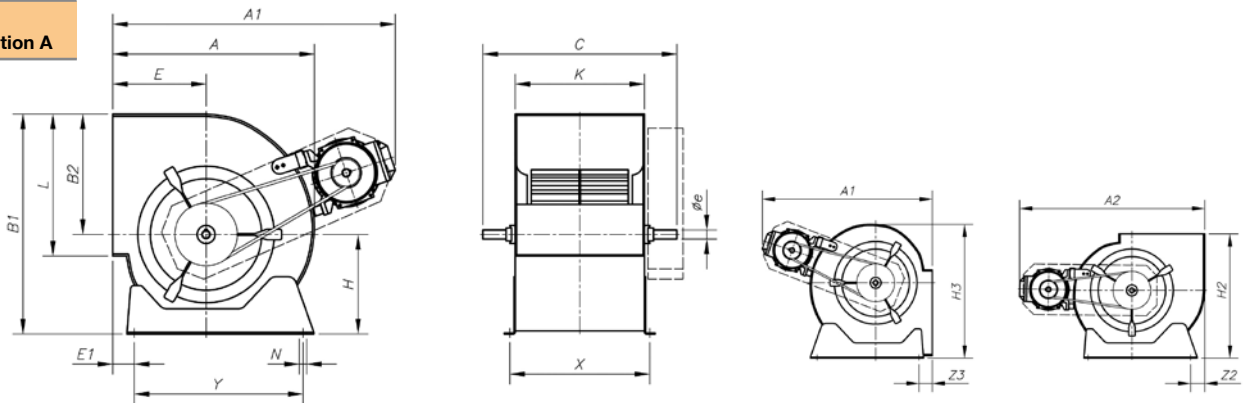

Model	A	A1	A2	B1	B2	C	E	E1	øe	H	H2	H3	K	L	N	X	Y	Z2	Z3
CBXT-7/7-0'25	316	430	475	333	189	360	152	64	20	144	320	341	230	208	9x13	258	225	44	36
CBXT-7/7-0'33	316	450	495	333	189	360	152	64	20	144	320	341	230	208	9x13	258	225	44	36
CBXT-7/7-0'5	316	450	495	333	189	360	152	64	20	144	320	341	230	208	9x13	258	225	44	36
CBXT-7/7-0'75	316	470	515	333	189	360	152	64	20	144	320	341	230	208	9x13	258	225	44	36
CBXT-7/7-1	316	470	515	333	189	360	152	64	20	144	320	341	230	208	9x13	258	225	44	36
CBXT-9/9-0'25	380	490	535	400	218	430	183	78	20	182	385	395	300	263	9x13	328	275	50	57
CBXT-9/9-0'33	380	520	565	400	218	430	183	78	20	182	385	395	300	263	9x13	328	275	50	57
CBXT-9/9-0'5	380	520	565	400	218	430	183	78	20	182	385	395	300	263	9x13	328	275	50	57
CBXT-9/9-0'75	380	540	585	400	218	430	183	78	20	182	385	395	300	263	9x13	328	275	50	57
CBXT-9/9-1	380	540	585	400	218	430	183	78	20	182	385	395	300	263	9x13	328	275	50	57
CBXT-9/9-1'5	380	590	605	400	218	430	183	78	20	182	385	395	300	263	9x13	328	275	50	57
CBXT-10/10-0'5	422	570	615	450	246	470	202	73	20	204	443	470	326	292	9x17	355	315	50	50
CBXT-10/10-0'75	422	590	635	450	246	470	202	73	20	204	443	470	326	292	9x17	355	315	50	50
CBXT-10/10-1	422	590	635	450	246	470	202	73	20	204	443	470	326	292	9x17	355	315	50	50
CBXT-10/10-1'5	422	610	655	450	246	470	202	73	20	204	443	470	326	292	9x17	355	315	50	50
CBXT-10/10-2	422	610	655	450	246	470	202	73	20	204	443	470	326	292	9x17	355	315	50	50
CBXT-12/12-0'5	493	645	690	526	290	560	230	82	25	236	498	555	387	345	9x17	415	390	35	70
CBXT-12/12-0'75	493	665	710	526	290	560	230	82	25	236	498	555	387	345	9x17	415	390	35	70
CBXT-12/12-1	493	665	710	526	290	560	230	82	25	236	498	555	387	345	9x17	415	390	35	70
CBXT-12/12-1'5	493	680	725	526	290	560	230	82	25	236	498	555	387	345	9x17	415	390	35	70
CBXT-12/12-2	493	680	725	526	290	560	230	82	25	236	498	555	387	345	9x17	415	390	35	70
CBXT-12/12-3	493	700	745	526	290	560	230	82	25	236	498	555	387	345	9x17	415	390	35	70

Dimensions in mm

CBXT
Installation B

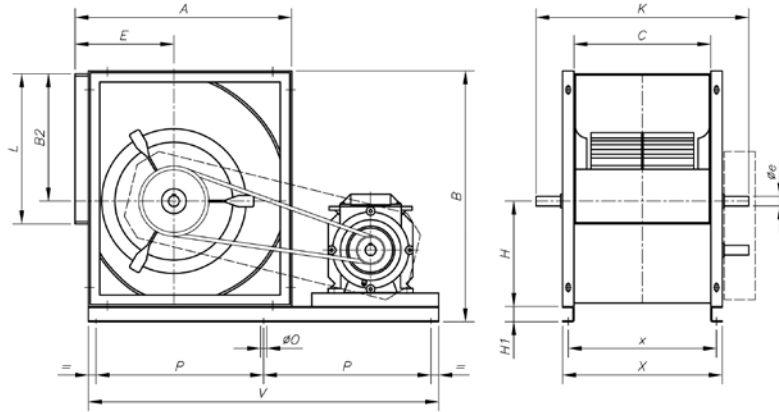

Model	A	B	B2	C	E	øe	H	H1	K	L	ø0	P	V	x	X
CBXT-15/15	583	672	348	473	265	25	284	40	650	404	12	415.5	895	505	533
CBXT-18/18	694	796	415	540	323	25	341	40	750	482	12	515.5	1115	572	600

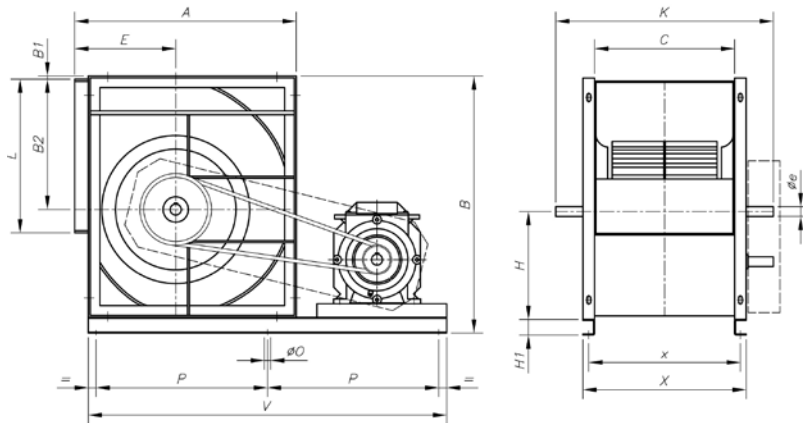

Model	A	B	B1	B2	C	E	øe	H	H1	K	L	ø0	P	V	x	X
CBXT-20/20	843	1023	35	523	603	375	35	405	60	923	603	12	617.5	1315	643	683
CBXT-22/22	913	1106	35	569	656	400	35	442	60	976	693	12	657.5	1395	696	736
CBXT-25/25	998	1221	35	642	765	423	35	484	60	1085	793	12	474.5	1575	805	845
CBXT-30/28	1206	1460	35	776	888	515	40	589	60	1208	933	12	817.5	1715	928	968

Characteristic Curves

Q = Airflow in m³/h, m³/s and cfm.

Pe = Static pressure in mm.w.c., Pa and in wg.

7/7 (1919)

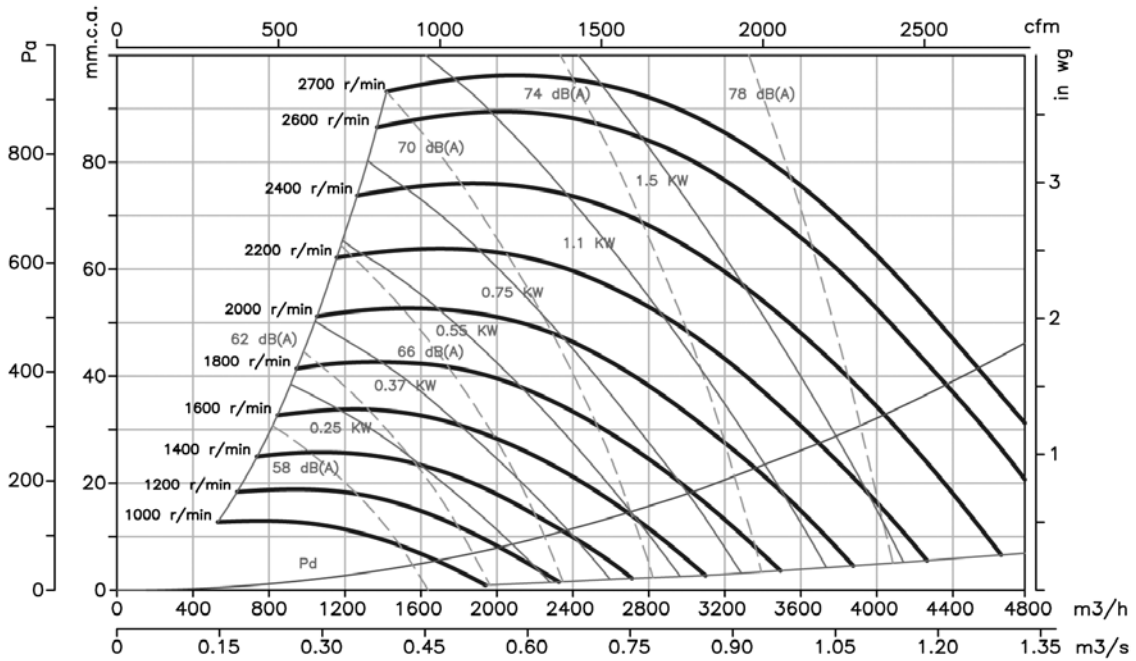

9/9 (2525)

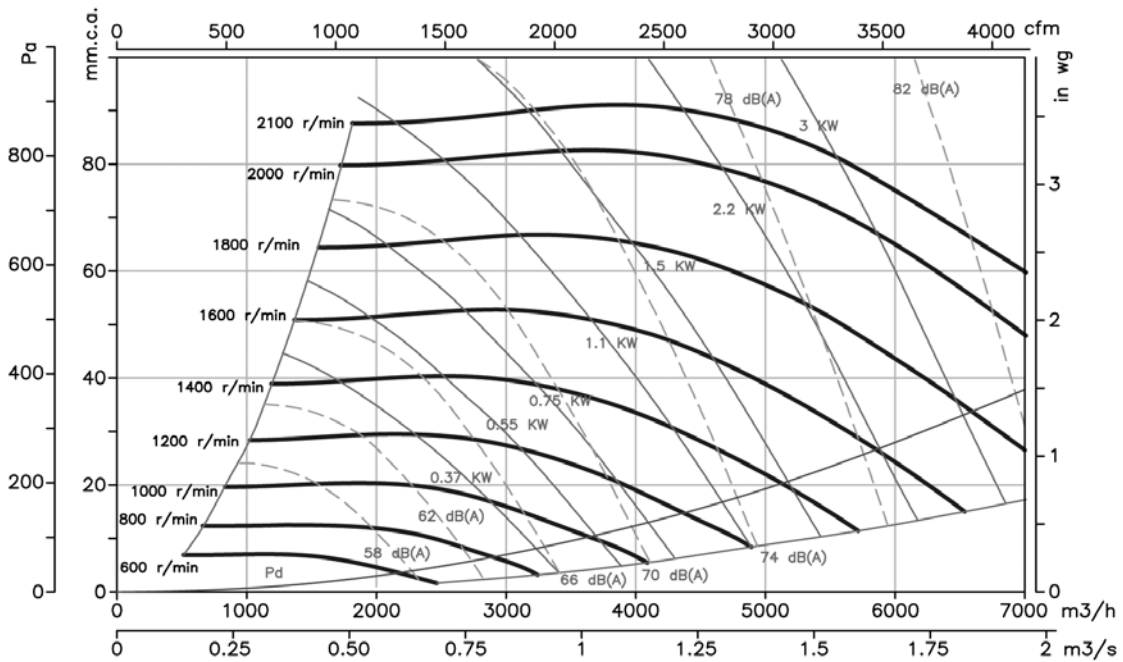

Characteristic Curves

Q = Airflow in m³/h, m³/s and cfm.

Pe = Static pressure in mm.w.c., Pa and in wg.

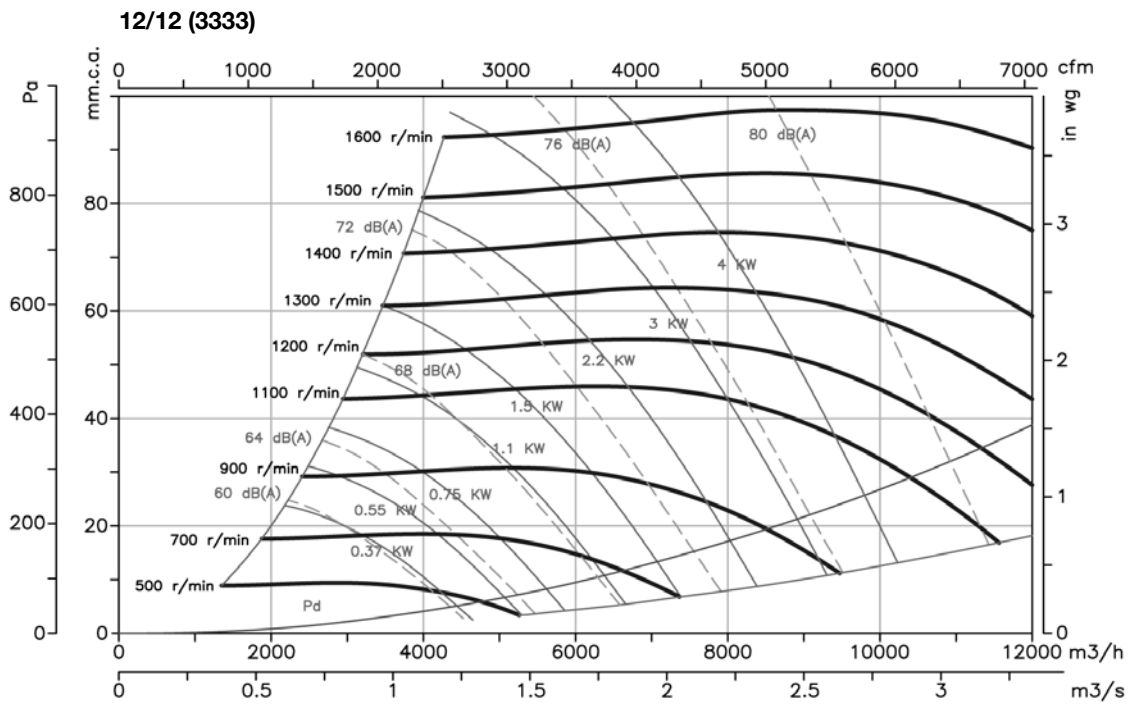
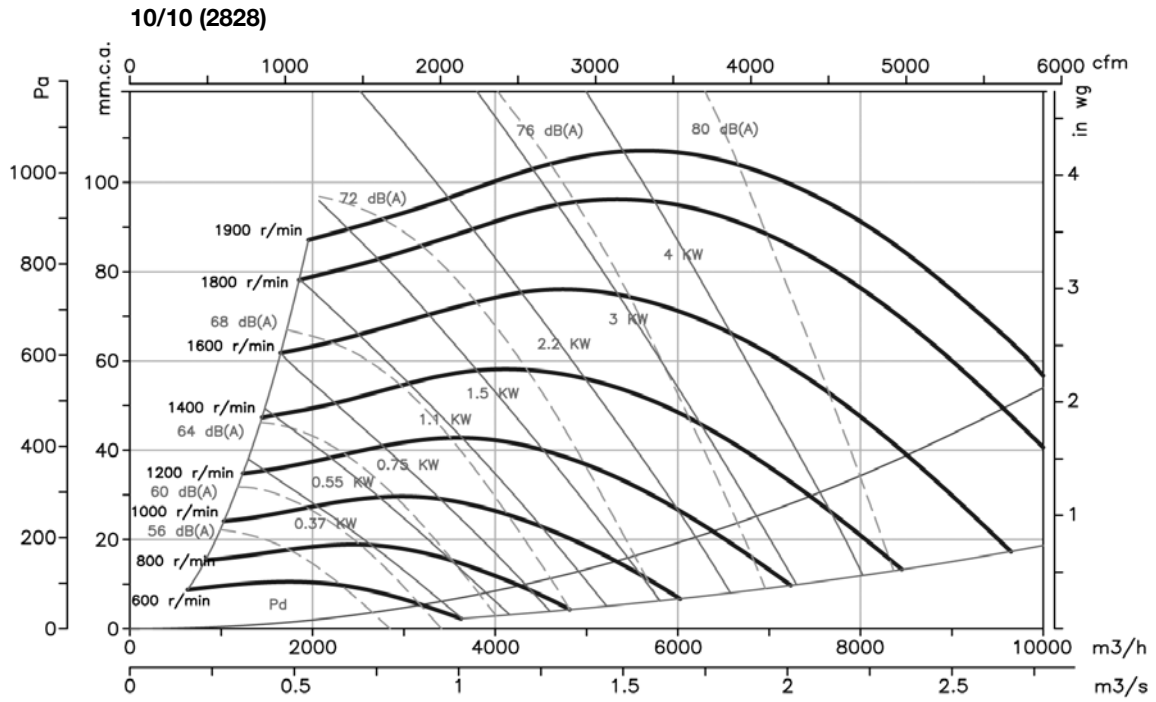

Characteristic Curves

Q = Airflow in m³/h, m³/s and cfm.

Pe = Static pressure in mm.w.c., Pa and in wg.

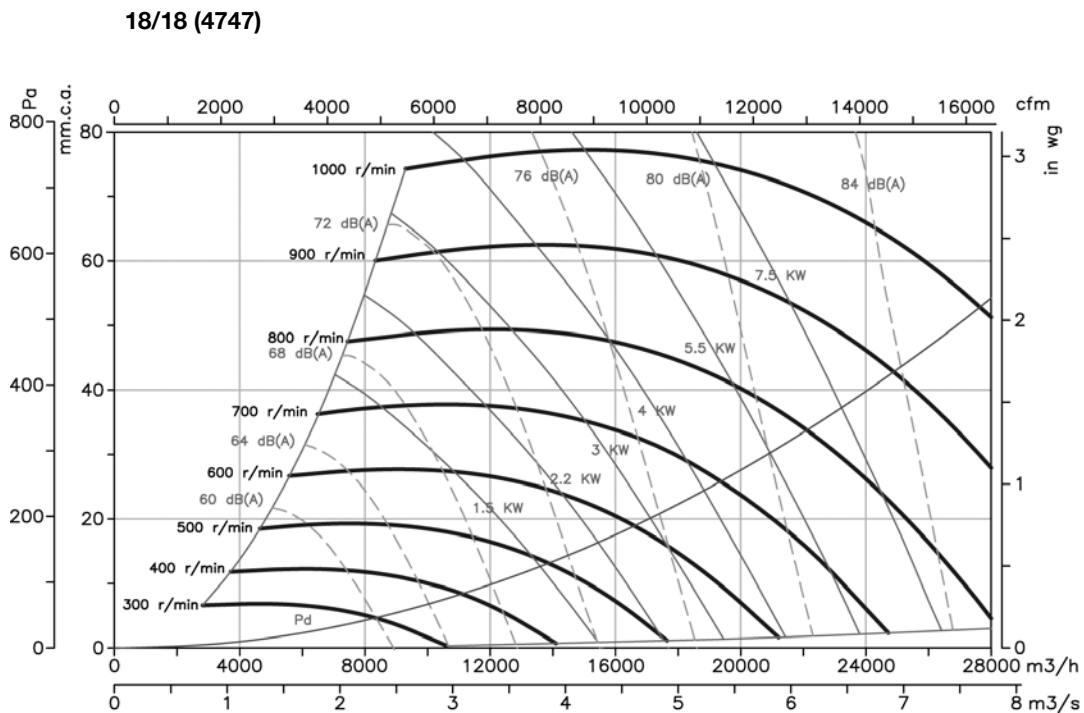
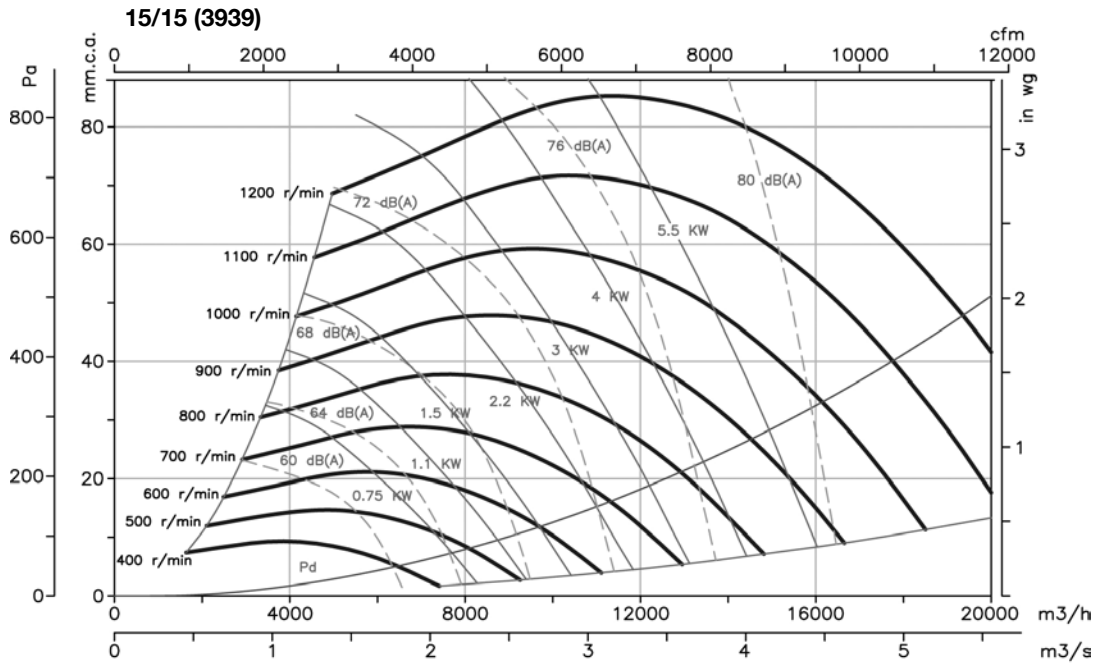

Characteristic Curves

Q = Airflow in m³/h, m³/s and cfm.

Pe= Static pressure in mm.w.c., Pa and in wg.

20/20

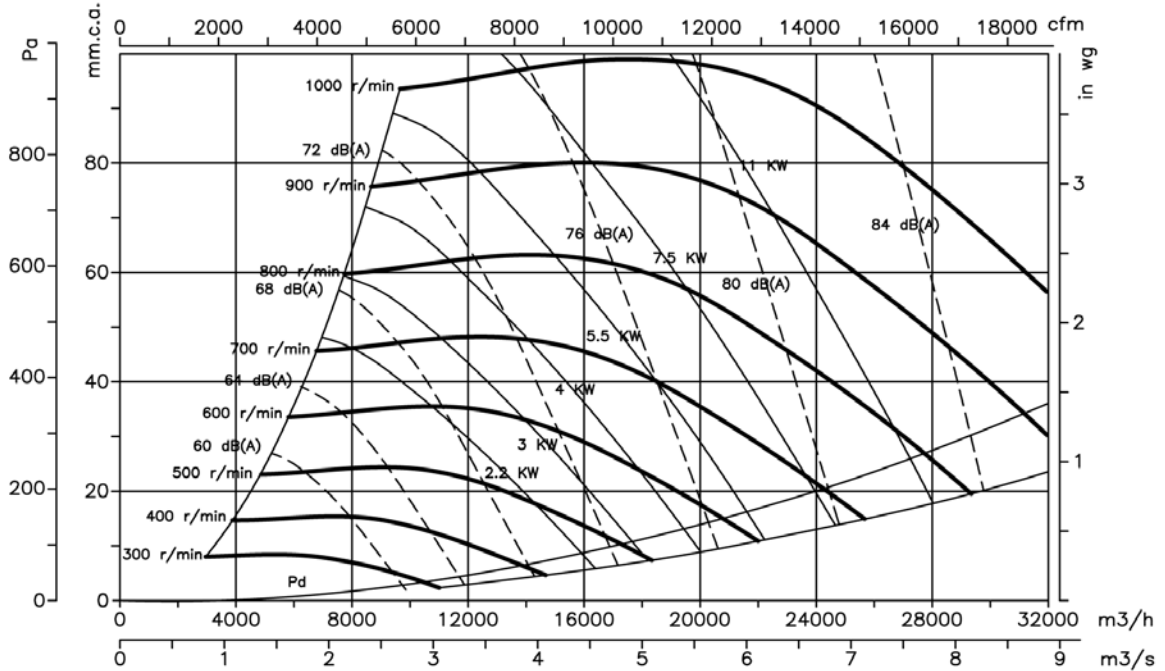

22/22

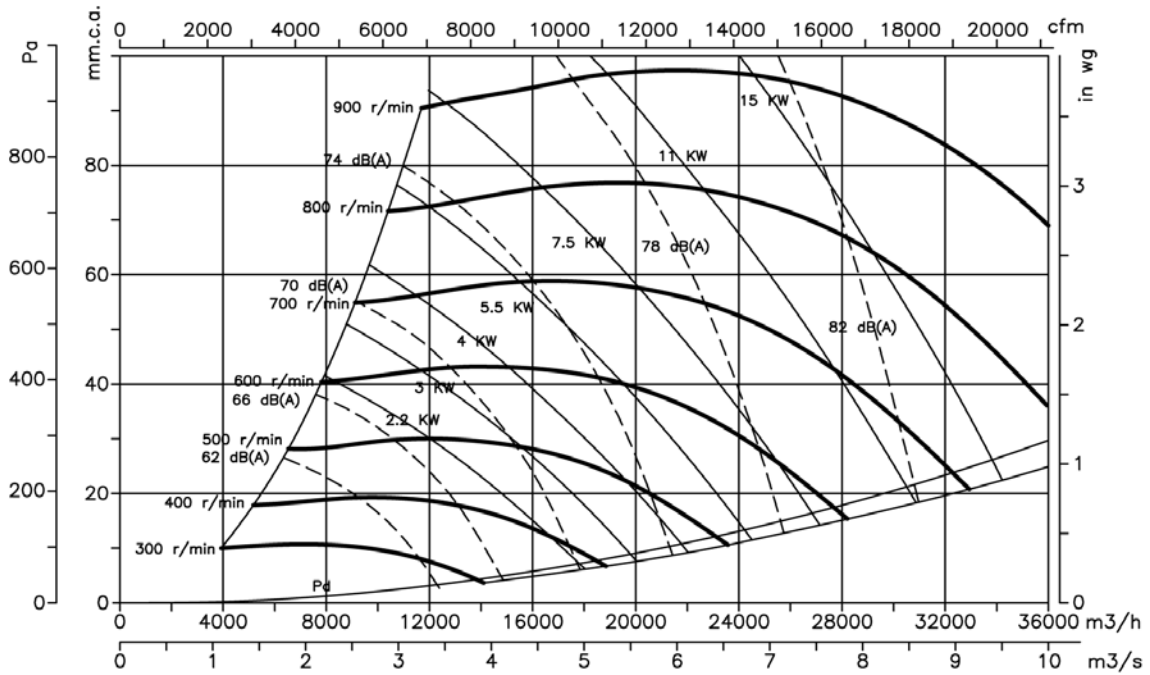

Characteristic Curves

Q = Airflow in m³/h, m³/s and cfm.

Pe = Static pressure in mm.w.c., Pa and in wg.

25/25

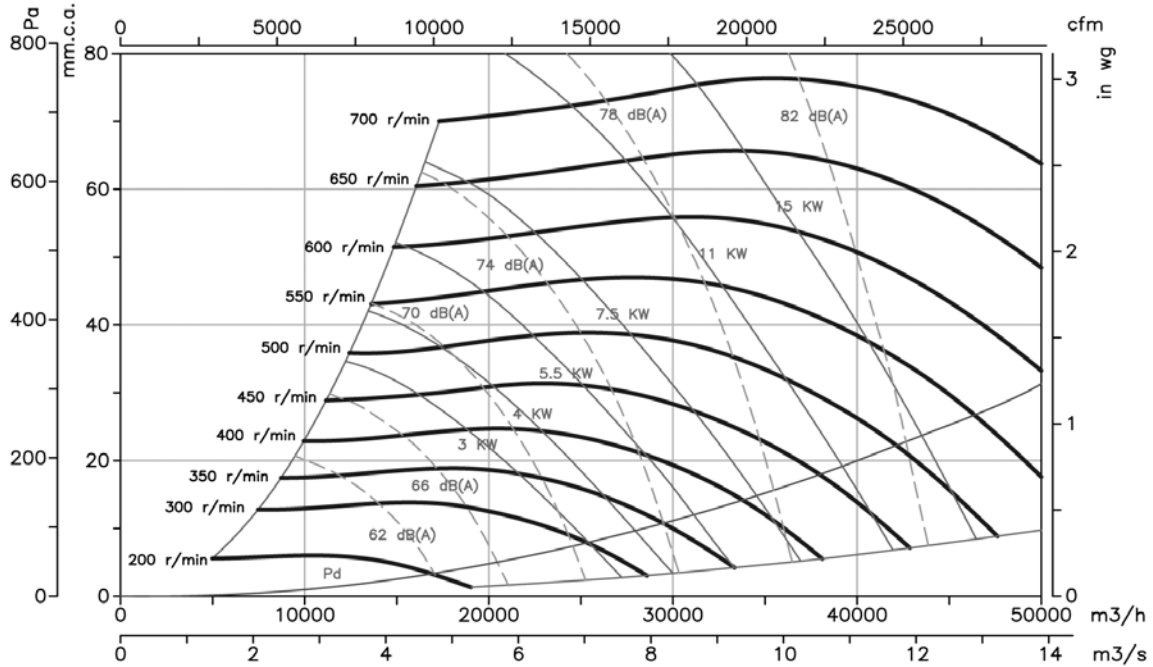

30/28

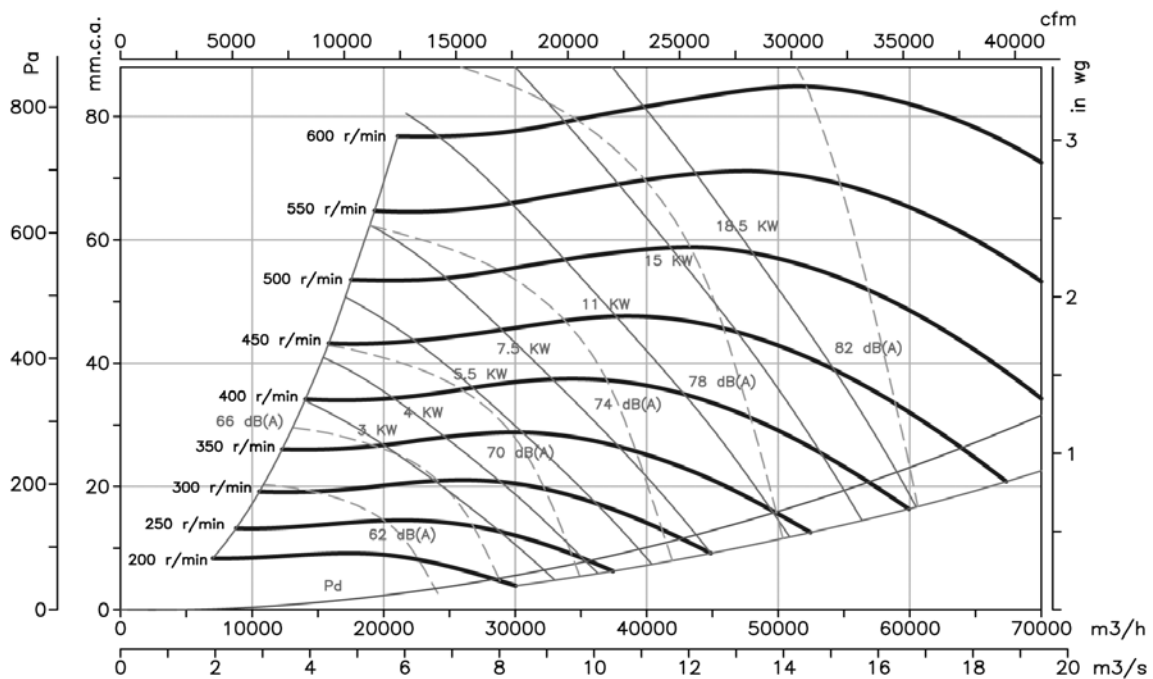

Accessories

See the accessories section.



CJBX CJBX/AL

CJBX: Soundproof belt-driven ventilation units fitted with double-inlet fans of the CBX, CBXC and CBXR series

CJBX/AL: Soundproof belt-driven ventilation units with aluminium profiles fitted with double-inlet fans of the CBX, CBXC and CBXR series



CJBX



CJBX/AL

Fan:

- Galvanised sheet steel structure with thermal insulation and soundproofing.
- Impeller with forward-facing blades made from galvanised sheet steel
- Stuffing-box for cable input
- CJBX/AL: with aluminium profiles

Motor:

- Motors with IE-2 efficiency, except for motors with lower powers than 0.75 kW, monophase motors or two-speed motors
- Class F motors with ball bearings, IP55 protection
- Three-phase 230/400V.-50Hz. (up to 5.5CV.) and 400/690V.-50Hz. (power over 5.5CV.)
- Max. temperature of air for transport: -20°C.+ 60°C.

Finish:

- Anticorrosive galvanized sheet steel.

On request:

- With circular inlet



High-quality, robust impeller, dynamically balanced in accordance with ISO-1940

Order code

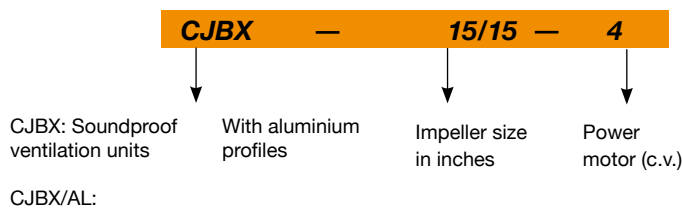

Technical characteristics

Model	Speed (r/min)	Maximum admissible current (A)			Installed Power (kW)	Maximum Airflow (m³/h)	Sound pressure level dB(A)	Approx. weight (Kg)	Assembly Type
		230V	400V	690V					
CJBX CJBX/AL 7/7-0.25	1090	1.1	0.64		0.18	1050	48	37.0	A
CJBX CJBX/AL 7/7-0.33	1220	1.4	0.78		0.25	1100	50	37.8	A
CJBX CJBX/AL 7/7-0.5	1420	1.8	1.05		0.37	1250	53	39.0	A
CJBX CJBX/AL 7/7-0.75	1600	2.5	1.45		0.55	1450	56	41.0	A
CJBX CJBX/AL 7/7-1	1790	3.3	1.90		0.75	1500	58	42.5	A
CJBX CJBX/AL 9/9-0.25	825	1.1	0.64		0.18	1700	45	48.0	A

Technical characteristics

Model			Speed (r/min)	Maximum admissible current (A)			Installed Power (kW)	Maximum Airflow (m³/h)	Sound pressure level dB(A)	Approx. weight (Kg)	Assembly Type
				230V	400V	690V					
CJBX	CJBX/AL	9/9-0.33	920	1.4	0.78	0.25	1800	48	50.0	A	
CJBX	CJBX/AL	9/9-0.5	1020	1.8	1.05	0.37	2200	51	51.5	A	
CJBX	CJBX/AL	9/9-0.75	1050	2.5	1.45	0.55	2900	55	54.5	A	
CJBX	CJBX/AL	9/9-1	1070	3.3	1.90	0.75	3200	56	56.0	A	
CJBX	CJBX/AL	9/9-1.5	1260	4.5	2.59	1.10	3750	60	59.0	A	
CJBX	CJBX/AL	10/10-0.5	845	1.8	1.05	0.37	2950	52	55.0	A	
CJBX	CJBX/AL	10/10-0.75	845	2.5	1.45	0.55	3800	56	57.0	A	
CJBX	CJBX/AL	10/10-1	960	3.3	1.90	0.75	4175	58	58.5	A	
CJBX	CJBX/AL	10/10-1.5	1070	4.5	2.59	1.10	4800	61	61.3	A	
CJBX	CJBX/AL	10/10-2	1140	6.0	3.45	1.50	5400	63	64.6	A	
CJBX	CJBX/AL	12/12-0.5	595	1.8	1.05	0.37	4200	52	69.0	A	
CJBX	CJBX/AL	12/12-0.75	675	2.5	1.45	0.55	4800	54	71.0	A	
CJBX	CJBX/AL	12/12-1	765	3.3	1.90	0.75	5400	57	72.4	A	
CJBX	CJBX/AL	12/12-1.5	855	4.5	2.59	1.10	5800	59	75.3	A	
CJBX	CJBX/AL	12/12-2	965	6.0	3.45	1.50	6500	62	78.6	A	
CJBX	CJBX/AL	12/12-3	1180	8.4	4.85	2.20	7400	65	87.0	A	
CJBX	CJBX/AL	15/15-0.75	525	2.5	1.45	0.55	5900	49	85.0	A	
CJBX	CJBX/AL	15/15-1	595	3.3	1.90	0.75	6500	52	86.4	A	
CJBX	CJBX/AL	15/15-1.5	635	4.5	2.59	1.10	7500	54	89.3	A	
CJBX	CJBX/AL	15/15-2	670	6.0	3.45	1.50	8200	56	92.6	A	
CJBX	CJBX/AL	15/15-3	740	8.4	4.85	2.20	9500	59	101.0	A	
CJBX	CJBX/AL	15/15-4	805	11.2	6.48	3.00	10600	61	103.0	A	
CJBX	CJBX/AL	15/15-5.5	965	15.0	8.65	4.00	12000	63	108.0	B	
CJBX	CJBX/AL	18/18-1.5	480	4.5	2.59	1.10	9000	48	122.0	A	
CJBX	CJBX/AL	18/18-2	605	6.0	3.45	1.50	9250	51	125.3	A	
CJBX	CJBX/AL	18/18-3	590	8.4	4.85	2.20	11500	54	133.7	A	
CJBX	CJBX/AL	18/18-4	640	11.2	6.48	3.00	13200	56	135.7	B	
CJBX	CJBX/AL	18/18-5.5	675	15.0	8.65	4.00	15000	58	141.0	B	
CJBX	CJBX/AL	18/18-7.5	760		11.40	6.60	5.50	17000	60	154.5	B
CJBX	CJBX/AL	20/20-2	430	6.0	3.45	1.50	11500	56	222.0	B	
CJBX	CJBX/AL	20/20-3	530	8.4	4.85	2.20	12800	57	230.5	B	
CJBX	CJBX/AL	20/20-4	575	11.2	6.48	3.00	14200	58	232.5	B	
CJBX	CJBX/AL	20/20-5.5	635	15.0	8.65	4.00	15500	61	237.5	B	
CJBX	CJBX/AL	20/20-7.5	675		11.40	6.60	5.50	17500	63	251.5	B
CJBX	CJBX/AL	20/20-10	725		14.80	8.50	7.50	20000	65	266.5	B
CJBX	CJBX/AL	22/22-2	385	6.0	3.45	1.50	14000	50	250.0	B	
CJBX	CJBX/AL	22/22-3	475	8.4	4.85	2.20	15000	54	257.0	B	
CJBX	CJBX/AL	22/22-4	515	11.2	6.48	3.00	17000	55	261.0	B	
CJBX	CJBX/AL	22/22-5.5	570	15.0	8.65	4.00	19000	57	265.0	B	
CJBX	CJBX/AL	22/22-7.5	605		11.40	6.60	5.50	21500	60	279.0	B
CJBX	CJBX/AL	22/22-10	725		14.80	8.50	7.50	22000	63	290.0	B
CJBX	CJBX/AL	22/22-15	765		21.00	12.10	11.00	27000	65	316.0	B
CJBX	CJBX/AL	25/25-3	375	8.4	4.85	2.20	17000	53	297.0	B	
CJBX	CJBX/AL	25/25-4	405	11.2	6.48	3.00	20500	55	299.0	B	
CJBX	CJBX/AL	25/25-5.5	450	15.0	8.65	4.00	22000	57	304.0	B	
CJBX	CJBX/AL	25/25-7.5	485		11.40	6.60	5.50	24500	59	318.0	B
CJBX	CJBX/AL	25/25-10	545		14.80	8.50	7.50	28000	61	329.0	B
CJBX	CJBX/AL	25/25-15	610		21.00	12.10	11.00	32000	64	349.0	B
CJBX	CJBX/AL	30/28-3	330	8.4	4.85	2.20	20000	54	380.0	B	
CJBX	CJBX/AL	30/28-4	360	11.2	6.48	3.00	22000	56	382.0	B	
CJBX	CJBX/AL	30/28-5.5	380	15.0	8.65	4.00	25000	59	387.0	B	
CJBX	CJBX/AL	30/28-7.5	380		11.40	6.60	5.50	31500	60	402.0	B
CJBX	CJBX/AL	30/28-10	410		14.80	8.50	7.50	36000	63	415.0	B
CJBX	CJBX/AL	30/28-15	430		21.00	12.10	11.00	42000	65	426.0	B
CJBX	CJBX/AL	30/28-20	480		28.50	16.50	15.00	48000	68	449.0	B

Dimensions in mm

CJBX

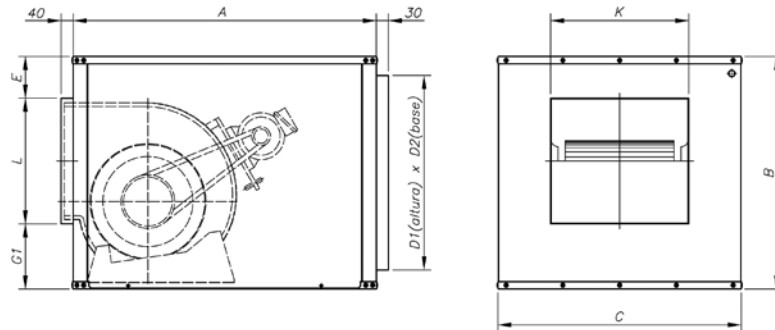

Installation A

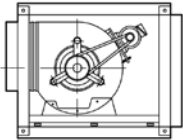

Installation B

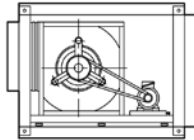

Model	A	B	C	D1xD2	E	G1	L	K
CJBX-7/7	650	460	500	364x404	114	142	204	226
CJBX-9/9	700	522	550	426x454	108,5	157,5	256	296
CJBX-10/10	750	575	600	479x504	107	182	286	322
CJBX-12/12	850	650	700	554x604	95	214	341	383
CJBX-15/15	1000	755	800	659x704	74	277	404	471
CJBX-18/18	1200	875	1000	779x904	57,5	337,5	480	537
CJBX-20/20	1400	1175	1100	1079x1004	147	428	600	600
CJBX-22/22	1460	1250	1250	1154x1154	145	413	692	653
CJBX-25/25	1550	1375	1450	1279x1354	152	431	792	762
CJBX-30/28	1800	1600	1650	1504x1554	140	528	932	885

CJBX vertical impulsion

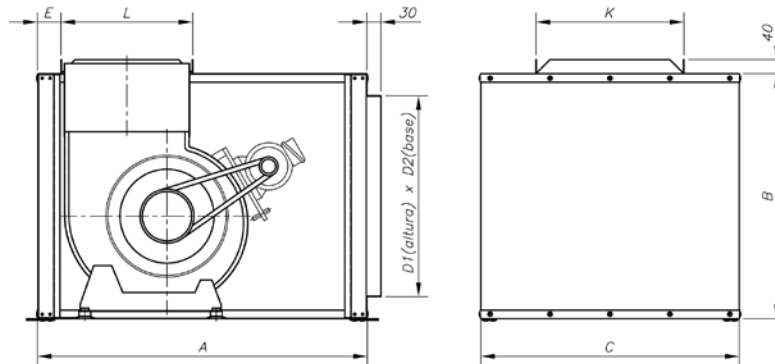

Installation A

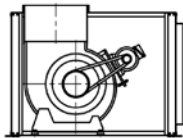

Installation B

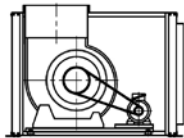

Model	A	B	C	D1xD2	E	L	K
CJBX-7/7	650	460	500	364x404	30	204	226
CJBX-9/9	700	522	550	426x454	30	256	296
CJBX-10/10	750	575	600	479x504	30	286	322
CJBX-12/12	850	650	700	554x604	30	341	383
CJBX-15/15	1000	755	800	659x704	30	404	471
CJBX-18/18	1200	875	1000	779x904	30	484	537
CJBX-20/20	1445	1175	1100	1079x1004	60	600	600
CJBX-22/22	1580	1250	1250	1154x1154	60	692	653
CJBX-25/25	1675	1375	1450	1279x1354	60	792	762
CJBX-30/28	1935	1600	1650	1504x1554	60	932	885

Dimensions in mm

CJBX/AL

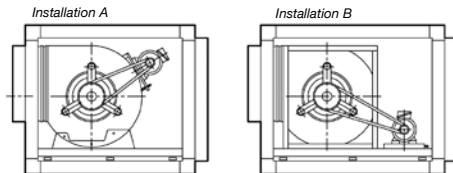
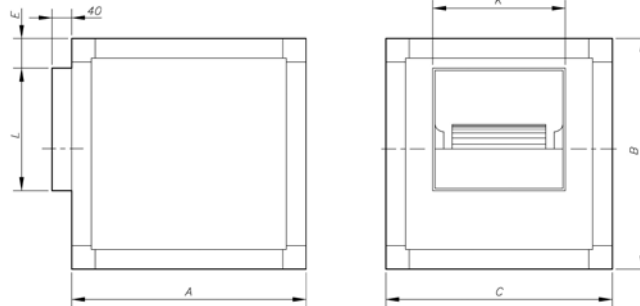

Model	A	B	C	E	L	K
CJBX/AL-7/7	650	460	460	75	216	238
CJBX/AL-9/9	700	520	520	75	268	305
CJBX/AL-10/10	750	575	575	75	296	330
CJBX/AL-12/12	850	650	650	75	346	390
CJBX/AL-15/15	1000	755	755	85	411	482
CJBX/AL-18/18	1200	1000	1000	185	491	550
CJBX/AL-20/20	1400	1170	1250	143	620	618
CJBX/AL-22/22	1480	1230	1300	127.5	711	681
CJBX/AL-25/25	1600	1350	1500	114	810	781
CJBX/AL-30/28	1850	1600	1700	125	949	906

CJBX/AL vertical impulsion

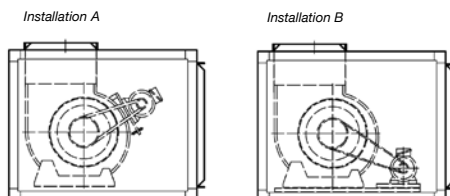
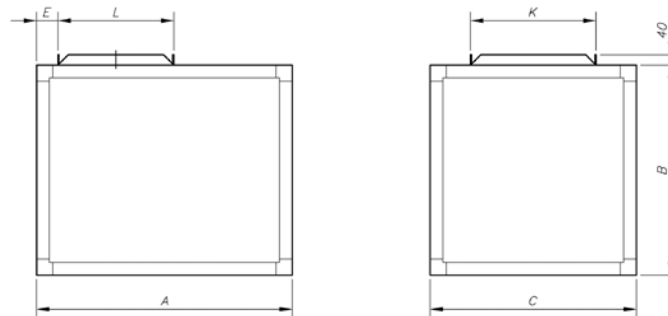

Model	A	B	C	E	L	K
CJBX/AL-7/7	650	460	460	75	216	238
CJBX/AL-9/9	700	520	520	75	268	305
CJBX/AL-10/10	750	575	575	75	296	330
CJBX/AL-12/12	850	650	650	75	346	390
CJBX/AL-15/15	1000	755	755	85	411	482
CJBX/AL-18/18	1200	1000	1000	185	491	550
CJBX/AL-20/20	1400	1170	1250	349.5	620	618
CJBX/AL-22/22	1480	1230	1300	342.5	711	681
CJBX/AL-25/25	1600	1350	1500	366.5	810	781
CJBX/AL-30/28	1850	1600	1700	459.5	949	906

Characteristic Curves

Q = Airflow in m³/h, m³/s and cfm.

Pe = Static pressure in mm.w.c., Pa and in wg.

7/7

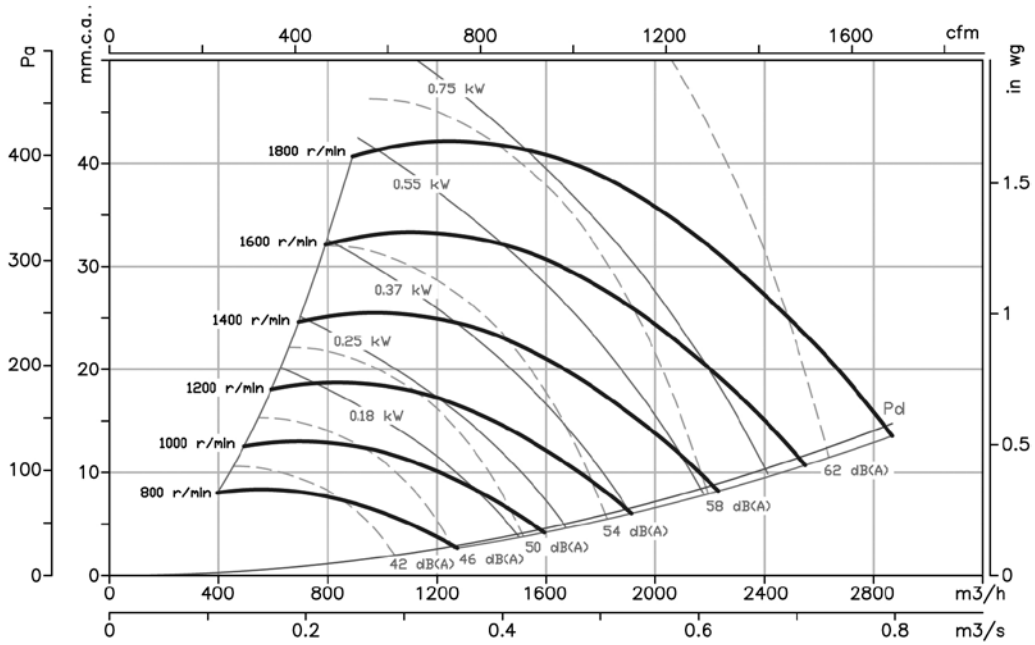

9/9

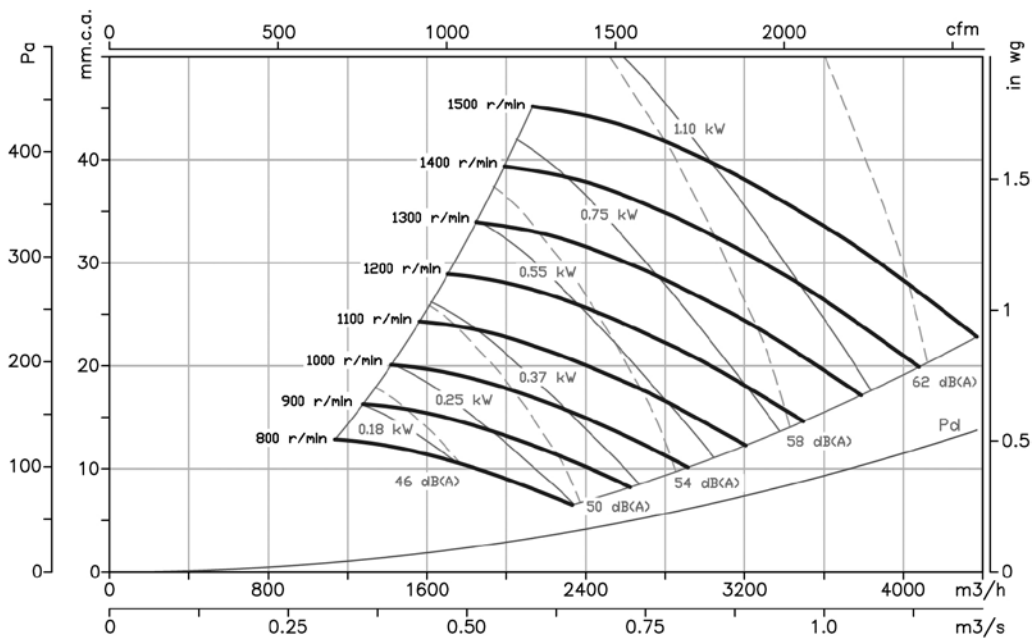

Characteristic Curves

Q = Airflow in m³/h, m³/s and cfm.

Pe = Static pressure in mm.w.c., Pa and in wg.

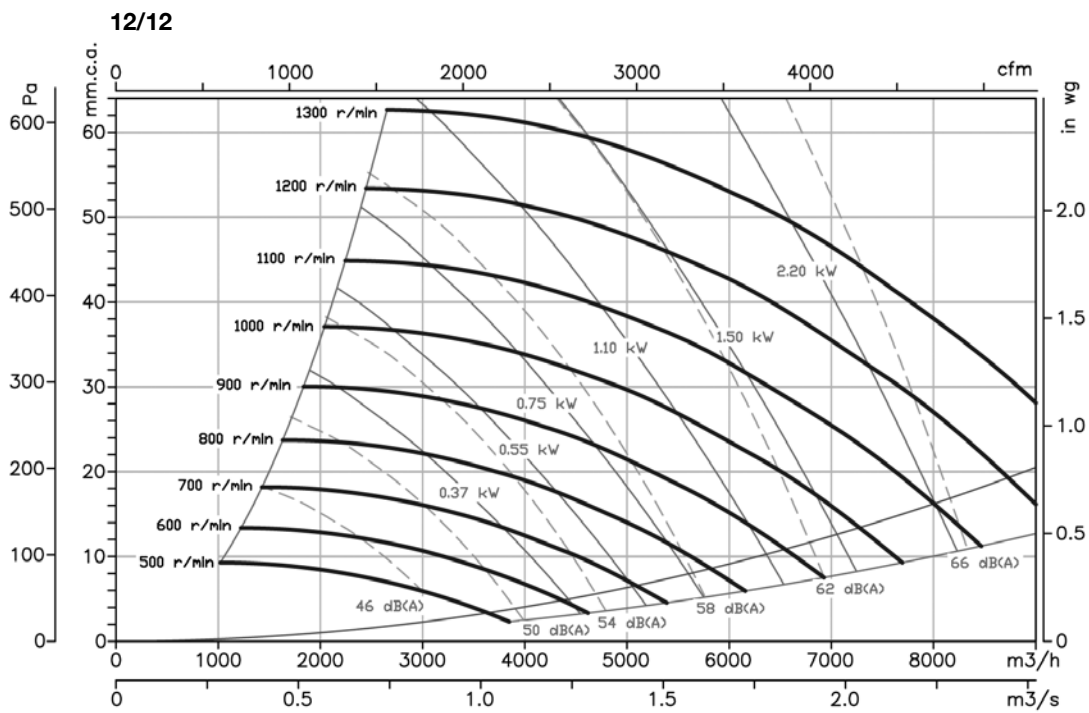
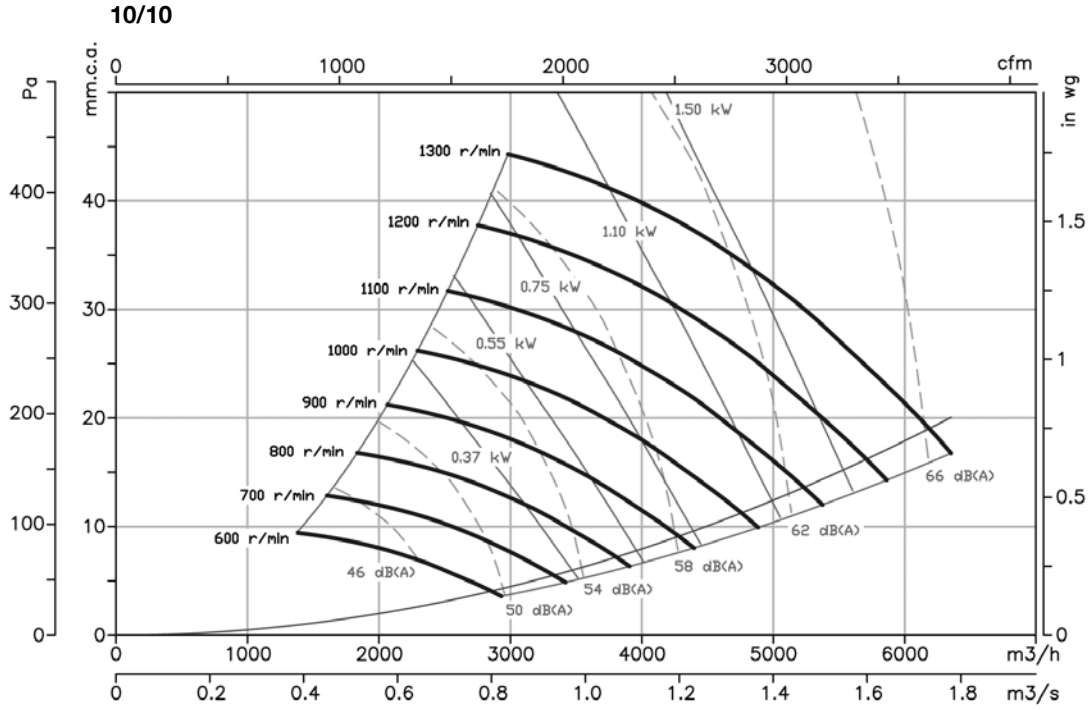

Characteristic Curves

Q = Airflow in m³/h, m³/s and cfm.

Pe = Static pressure in mm.w.c., Pa and in wg.

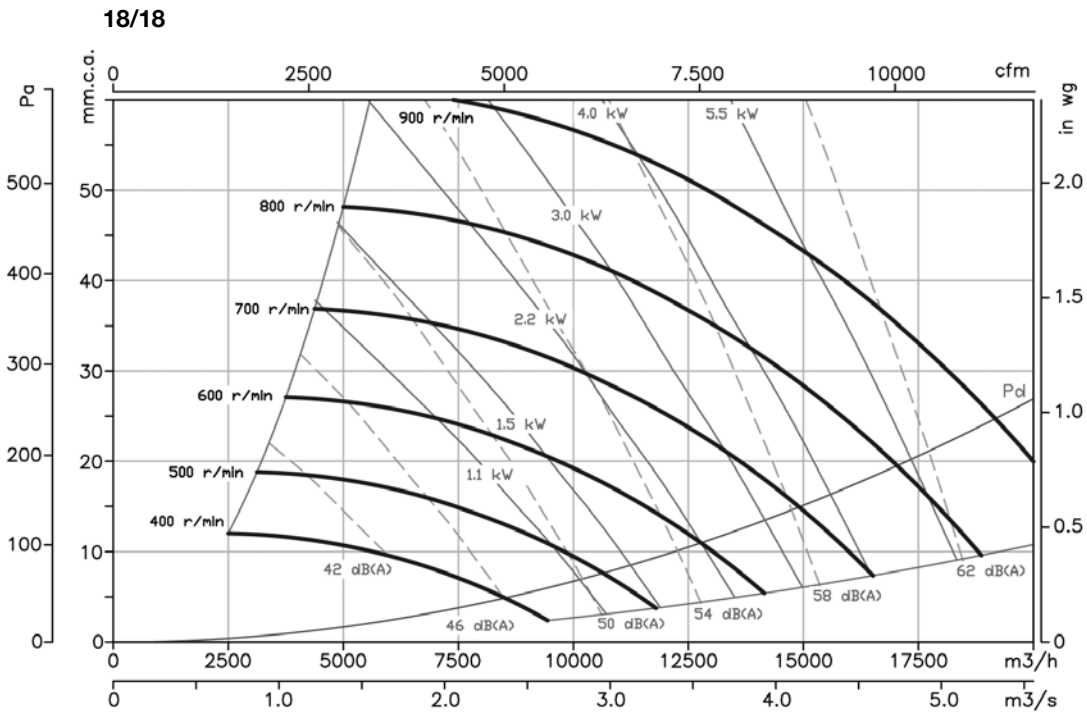
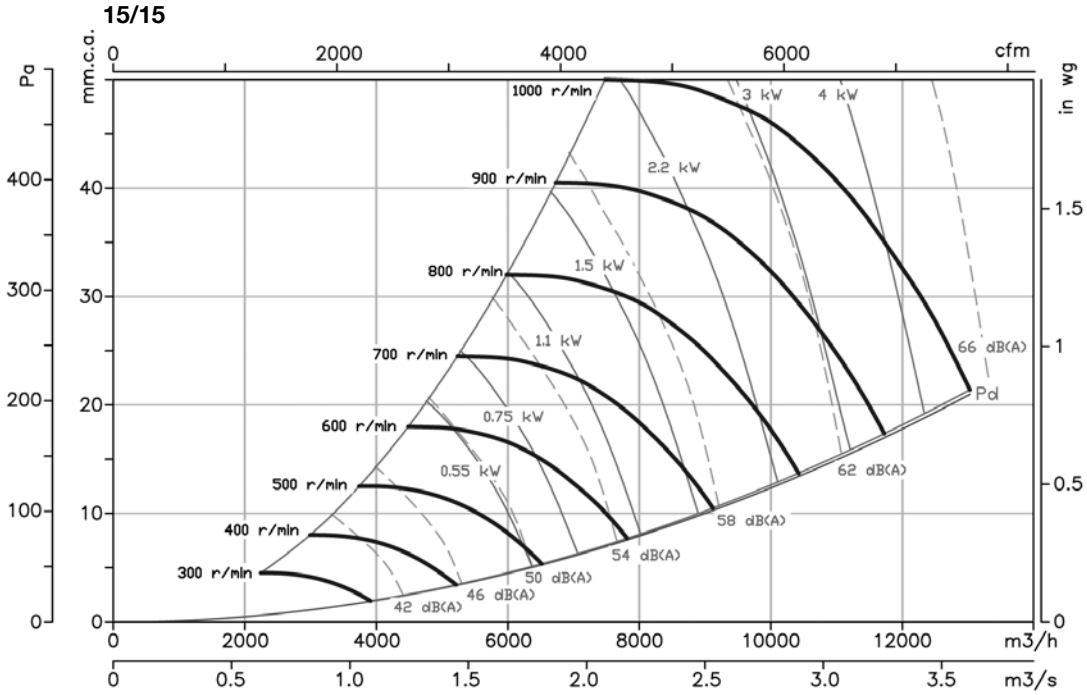

Characteristic Curves

Q = Airflow in m³/h, m³/s and cfm.

Pe = Static pressure in mm.w.c., Pa and in wg.

20/20

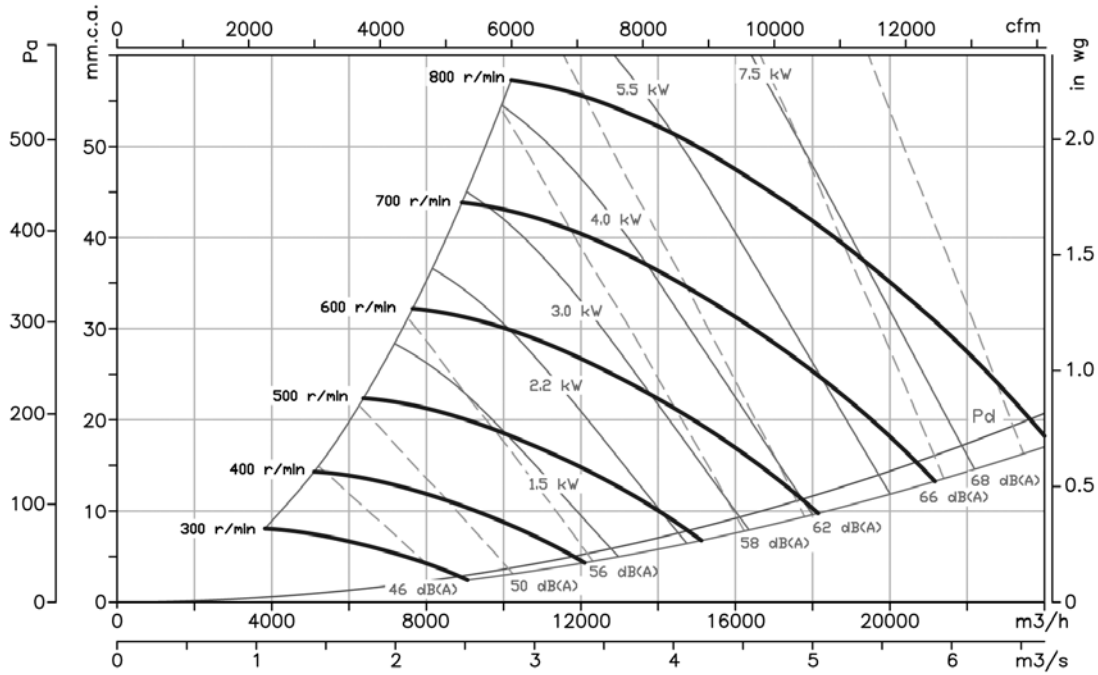

22/22

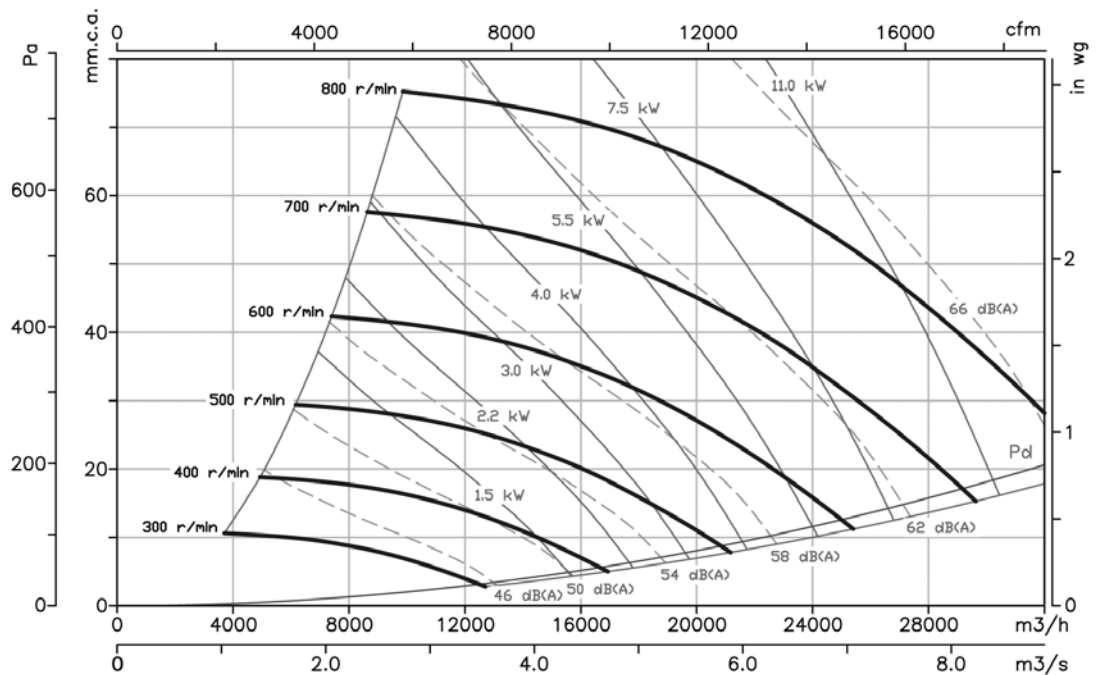

Characteristic Curves

Q = Airflow in m³/h, m³/s and cfm.

Pe= Static pressure in mm.w.c., Pa and in wg.

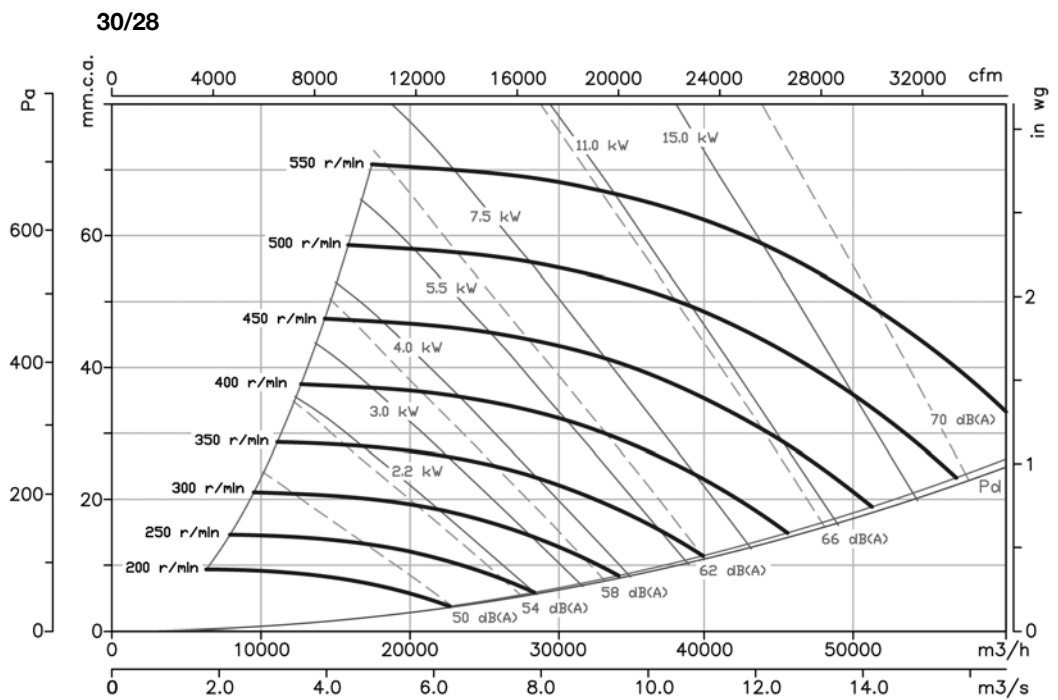
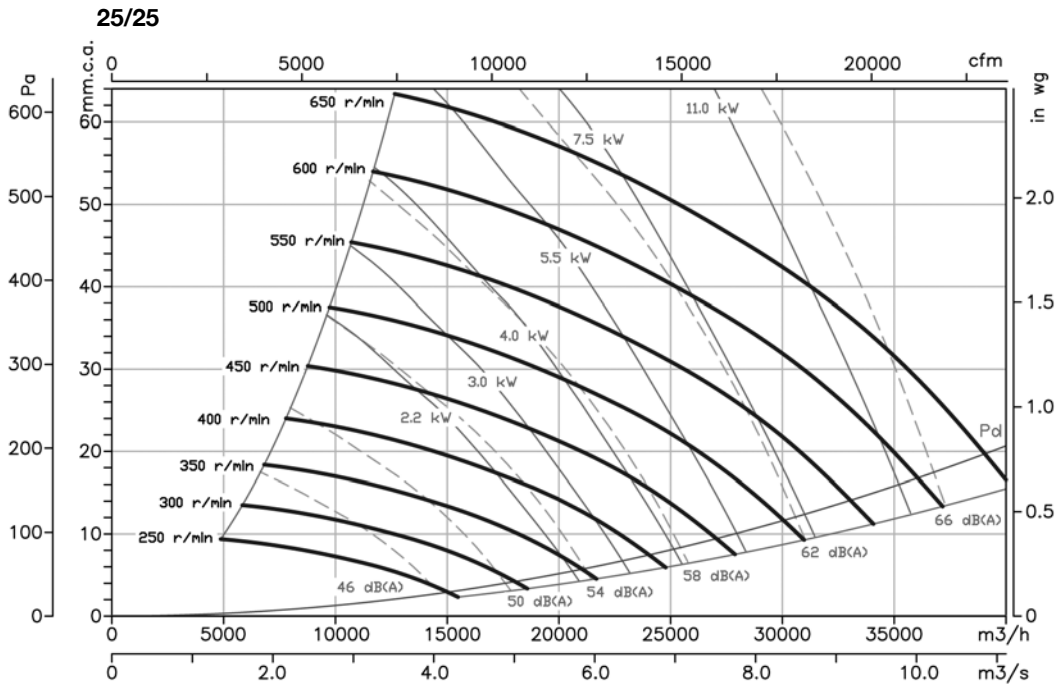

Accessories

See the accessories section.



CDXR CDXRT CJDXR

CDXR: Double-inlet, belt-driven centrifugal fans with axis outlet on both sides and impeller with backward-facing blades

CDXRT: Double-inlet, belt-driven centrifugal fans with electric motor, pulley, belt kit and standardised protectors and impeller with backward-facing blades.

CJDXR: Soundproof ventilation units with backward-facing blades, fitted with CDXR series fans on rubber dampers



CDXR



CDXRT



CJDXR

Fan:

- Galvanized sheet steel casing
- Impeller with backward-facing blades made from galvanised sheet steel
- Galvanised sheet steel structure with thermal insulation and soundproofing (CJDXR)
- Stuffing-box for cable input (CJDXR)

Motor:

- Motors with IE-2 efficiency, except for motors with lower powers than 0.75 kW, monophase motors or two-speed motors
- Class F motors with ball bearings, IP55 protection
- Three-phase 230/400V, 50Hz (up to 5.5CV) and 400/690V, 50Hz (power over 5.5CV)
- Max. temperature of air for transport: -20°C. +60°C.

Finish:

- Anticorrosive galvanized sheet steel.

On request:

- Different outlet positions
- Special windings for different voltages
- With two speed motors

Order code

CDXR — 450

CDXR: Centrifugal double-inlet fans with axis outlet and impeller with backward-facing blades.

Impeller size in mm

CDXRT — 450 — 3

CDXRT: Double-inlet, belt-driven centrifugal fans with electric motor impeller, with backward-facing blades.

Impeller size in mm

Motor power (c.v.)

CJDXR: Ventilation units with impeller with backward-facing blades.

Technical characteristics

Model	Max. Speed (r/min)	Installed Power (kW)	Maximum Airflow (m³/h)	Air Temperature (°C)		Approx. weight (Kg)
				min.	max.	
CDXR-200	4900	2,2	3950	-20	85	10,0
CDXR-250	4100	3,0	5500	-20	85	18,0
CDXR-315	3200	4,0	10550	-20	85	32,6
CDXR-355	2800	5,5	13950	-20	85	42,7
CDXR-400	2400	5,5	16000	-20	85	50,6
CDXR-450	2200	7,5	20700	-20	85	67,5
CDXR-500	2000	11,0	27200	-20	85	84,2
CDXR-560	1800	15,0	34710	-20	85	142,0
CDXR-630	1700	22,0	47000	-20	85	168,0
CDXR-710	1400	22	53750	-20	85	223

Technical characteristics

Model			Max. Speed (r/min)	Installed Power (kW)	Maximum Airflow (m³/h)	Air Temperature (°C)		Approx. weight (Kg)	Assembly Type
						min.	max.		
CDXRT	CJDXR	355-0.5	1085	0.37	5600	-20	85	47.7	A
CDXRT	CJDXR	355-0.75	1230	0.55	6400	-20	85	49.3	A
CDXRT	CJDXR	355-1	1360	0.75	7100	-20	85	50.9	A
CDXRT	CJDXR	355-1.5	1540	1.10	8060	-20	85	52.6	A
CDXRT	CJDXR	355-2	1700	1.50	8890	-20	85	55.6	A
CDXRT	CJDXR	355-3	1930	2.20	10100	-20	85	58.4	A
CDXRT	CJDXR	355-4	2180	3.00	11395	-20	85	65.7	A
CDXRT	CJDXR	355-5.5	2400	4.00	12545	-20	85	72.7	B
CDXRT	CJDXR	355-7.5	2670	5.50	13955	-20	85	85.7	B
CDXRT	CJDXR	400-0.75	1010	0.55	7340	-20	85	57.2	A
CDXRT	CJDXR	400-1	1130	0.75	8140	-20	85	58.8	A
CDXRT	CJDXR	400-1.5	1290	1.10	9350	-20	85	60.5	A
CDXRT	CJDXR	400-2	1420	1.50	10260	-20	85	63.5	A
CDXRT	CJDXR	400-3	1620	2.20	11650	-20	85	66.3	A
CDXRT	CJDXR	400-4	1820	3.00	13110	-20	85	73.6	A
CDXRT	CJDXR	400-5.5	2000	4.00	14430	-20	85	80.6	B
CDXRT	CJDXR	400-7.5	2230	5.50	16040	-20	85	93.6	B
CDXRT	CJDXR	450-1	940	0.75	9500	-20	85	75.7	A
CDXRT	CJDXR	450-1.5	1075	1.10	10750	-20	85	77.4	A
CDXRT	CJDXR	450-2	1190	1.50	11960	-20	85	80.4	A
CDXRT	CJDXR	450-3	1340	2.20	13600	-20	85	83.2	A
CDXRT	CJDXR	450-4	1510	3.00	15100	-20	85	90.5	A
CDXRT	CJDXR	450-5.5	1670	4.00	16835	-20	85	97.5	B
CDXRT	CJDXR	450-7.5	1850	5.50	18500	-20	85	110.5	B
CDXRT	CJDXR	450-10	2060	7.50	20760	-20	85	120.5	B
CDXRT	CJDXR	500-1.5	880	1.10	12460	-20	85	94.1	A
CDXRT	CJDXR	500-2	970	1.50	13815	-20	85	97.1	A
CDXRT	CJDXR	500-3	1100	2.20	15700	-20	85	99.9	A
CDXRT	CJDXR	500-4	1240	3.00	17650	-20	85	107.2	A
CDXRT	CJDXR	500-5.5	1370	4.00	19430	-20	85	114.2	B
CDXRT	CJDXR	500-7.5	1510	5.50	21600	-20	85	127.2	B
CDXRT	CJDXR	500-10	1675	7.50	23950	-20	85	137.2	B
CDXRT	CJDXR	500-15	1910	11.00	27220	-20	85	156.2	B
CDXRT	CJDXR	560-2	810	1.50	15620	-20	85	154.9	A
CDXRT	CJDXR	560-3	925	2.20	17830	-20	85	157.7	A
CDXRT	CJDXR	560-4	1050	3.00	20380	-20	85	165.0	A
CDXRT	CJDXR	560-5.5	1150	4.00	22170	-20	85	172.0	B
CDXRT	CJDXR	560-7.5	1290	5.50	24940	-20	85	185.0	B
CDXRT	CJDXR	560-10	1420	7.50	27658	-20	85	195.0	B
CDXRT	CJDXR	560-15	1610	11.00	31050	-20	85	214.0	B
CDXRT	CJDXR	560-20	1800	15.00	34710	-20	85	227.0	B
CDXRT	CJDXR	630-3	740	2.20	21210	-20	85	183.7	A
CDXRT	CJDXR	630-4	830	3.00	23860	-20	85	191.0	A
CDXRT	CJDXR	630-5.5	920	4.00	26260	-20	85	198.0	B
CDXRT	CJDXR	630-7.5	1020	5.50	29200	-20	85	211.0	B
CDXRT	CJDXR	630-10	1135	7.50	32385	-20	85	221.0	B
CDXRT	CJDXR	630-15	1285	11.00	36800	-20	85	240.0	B
CDXRT	CJDXR	630-20	1450	15.00	41415	-20	85	253.0	B
CDXRT	CJDXR	630-25	1550	18.50	44410	-20	85	270.0	B
CDXRT	CJDXR	630-30	1640	22.00	47050	-20	85	313.0	B
CDXRT	CJDXR	710-3	580	2.20	23200	-20	85	238.7	A
CDXRT	CJDXR	710-4	655	3.00	26200	-20	85	246.0	A
CDXRT	CJDXR	710-5.5	730	4.00	29200	-20	85	253.0	B
CDXRT	CJDXR	710-7.5	805	5.50	32200	-20	85	266.0	B
CDXRT	CJDXR	710-10	890	7.50	35600	-20	85	276.0	B
CDXRT	CJDXR	710-15	1015	11.00	40600	-20	85	295.0	B
CDXRT	CJDXR	710-20	1140	15.00	45600	-20	85	308.0	B
CDXRT	CJDXR	710-25	1225	18.50	49000	-20	85	325.0	B
CDXRT	CJDXR	710-30	1300	22.00	52000	-20	85	368.0	B

Dimensions in mm

CDXR 200 - 250

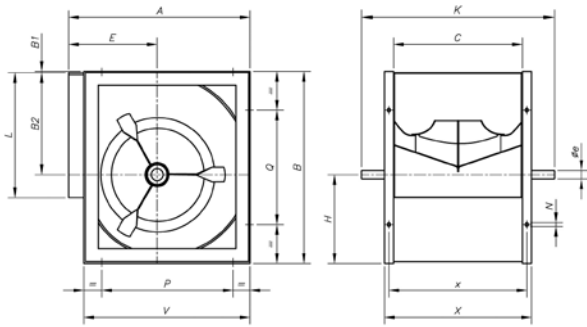

CDXR 315...710

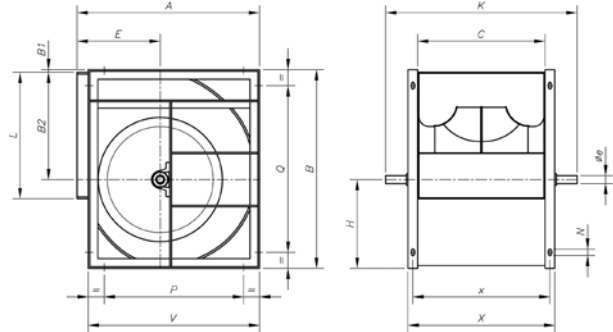

	A	B	B1	B2	C	E	øe	H	K	L	N	P	Q	V	X	x
CDXR-200	343	370	4	215	256	164	20	151	420	256	11x16	224	224	306	306	281
CDXR-250	419	461	4	270	322	195	20	187	490	322	11x16	224	224	384	372	347
CDXR-315	518	578	3	340	404	236	25	235	640	404	13x18	280	280	480	464	434
CDXR-355	578	655	6	383	453	261	30	266	700	453	13x18	355	355	548	533	493
CDXR-400	651	736	4,5	431,5	507	290	30	300	760	507	13x18	355	355	613	587	547
CDXR-450	728	827	5	486	569	322	35	336	845	569	13x18	530	530	681	649	609
CDXR-500	800	918	5	538	638	352	35	375	915	638	13x18	530	530	750	718	678
CDXR-560	893	1030	8	602	715	390	40	420	1000	715	13x18	530	530	845	815	765
CDXR-630	999	1157	7	678,5	801	434	45	471,5	1090	801	13x18	530	530	946	901	851
CDXR-710	1121	1303	7	765	898	485	50	531	1255	898	17x22	630	630	1058	998	948

CDXRT Installation A

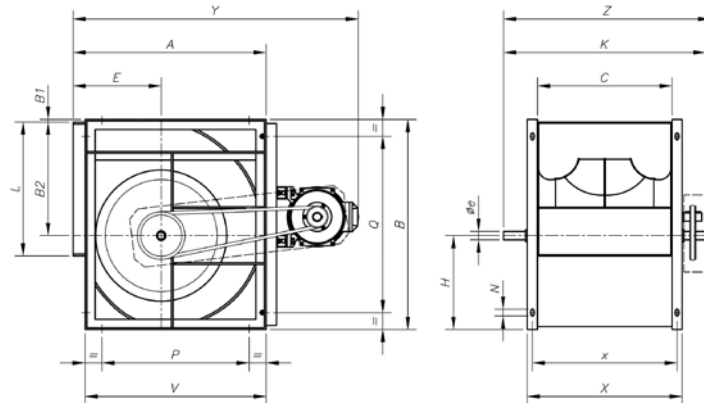

Model	A	B	B1	B2	C	E	øe	H	K	L	N	P	Q	V	X	x	Y	Z
CDXRT-355-0'5	578	655	6	383	453	261	30	266	700	453	13x18	355	355	548	533	493	830	780
CDXRT-355-0'75	578	655	6	383	453	261	30	266	700	453	13x18	355	355	548	533	493	850	780
CDXRT-355-1	578	655	6	383	453	261	30	266	700	453	13x18	355	355	548	533	493	850	780
CDXRT-355-1'5	578	655	6	383	453	261	30	266	700	453	13x18	355	355	548	533	493	870	780
CDXRT-355-2	578	655	6	383	453	261	30	266	700	453	13x18	355	355	548	533	493	870	780
CDXRT-355-3	578	655	6	383	453	261	30	266	700	453	13x18	355	355	548	533	493	885	780
CDXRT-355-4	578	655	6	383	453	261	30	266	700	453	13x18	355	355	548	533	493	885	780
CDXRT-400-0'75	651	736	4,5	431,5	507	290	30	300	760	507	13x18	355	355	613	587	547	925	840
CDXRT-400-1	651	736	4,5	431,5	507	290	30	300	760	507	13x18	355	355	613	587	547	925	840
CDXRT-400-1'5	651	736	4,5	431,5	507	290	30	300	760	507	13x18	355	355	613	587	547	940	840
CDXRT-400-2	651	736	4,5	431,5	507	290	30	300	760	507	13x18	355	355	613	587	547	940	840
CDXRT-400-3	651	736	4,5	431,5	507	290	30	300	760	507	13x18	355	355	613	587	547	956	840
CDXRT-400-4	651	736	4,5	431,5	507	290	30	300	760	507	13x18	355	355	613	587	547	956	840
CDXRT-450-1	728	827	5	486	569	322	35	336	845	569	13x18	530	530	681	649	609	1000	925
CDXRT-450-1'5	728	827	5	486	569	322	35	336	845	569	13x18	530	530	681	649	609	1020	925
CDXRT-450-2	728	827	5	486	569	322	35	336	845	569	13x18	530	530	681	649	609	1020	925
CDXRT-450-3	728	827	5	486	569	322	35	336	845	569	13x18	530	530	681	649	609	1035	925
CDXRT-450-4	728	827	5	486	569	322	35	336	845	569	13x18	530	530	681	649	609	1035	925
CDXRT-500-1'5	800	918	5	538	638	352	35	375	915	638	13x18	530	530	750	718	678	1090	995
CDXRT-500-2	800	918	5	538	638	352	35	375	915	638	13x18	530	530	750	718	678	1090	995
CDXRT-500-3	800	918	5	538	638	352	35	375	915	638	13x18	530	530	750	718	678	1105	995
CDXRT-500-4	800	918	5	538	638	352	35	375	915	638	13x18	530	530	750	718	678	1105	995
CDXRT-560-2	893	1030	8	602	715	390	40	420	1000	715	13x18	530	530	845	815	765	1185	1080
CDXRT-560-3	893	1030	8	602	715	390	40	420	1000	715	13x18	530	530	845	815	765	1205	1080
CDXRT-560-4	893	1030	8	602	715	390	40	420	1000	715	13x18	530	530	845	815	765	1205	1080
CDXRT-630-3	999	1157	7	678,5	801	434	45	471,5	1090	801	13x18	530	530	946	901	851	1310	1170
CDXRT-630-4	999	1157	7	678,5	801	434	45	471,5	1090	801	13x18	530	530	946	901	851	1310	1170
CDXRT-710-3	1121	1303	7	765	898	485	50	531	1255	898	17x22	630	630	1058	998	948	1435	1335
CDXRT-710-4	1121	1303	7	765	898	485	50	531	1255	898	17x22	630	630	1058	998	948	1435	1335

Dimensions in mm

**CDXRT
Installation B**

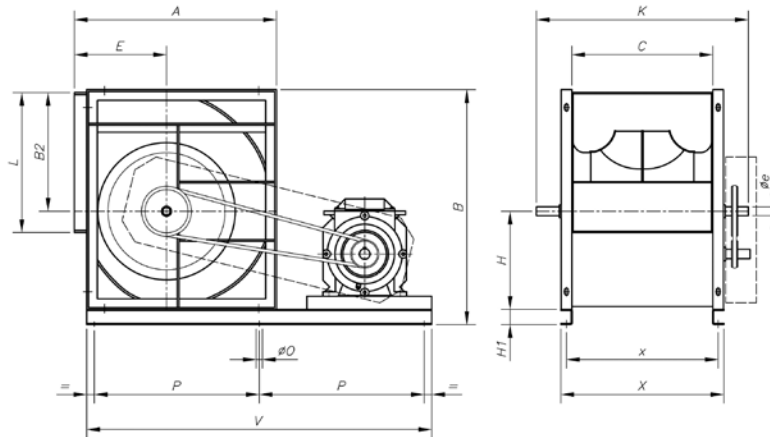

Model	A	B	B2	C	E	øe	H	H1	K	L	øO	P	V	x	X
CDXRT-355-5'5	578	715	383	453	261	30	266	60	700	453	12	495	1070	493	533
CDXRT-355-7'5	578	715	383	453	261	30	266	60	700	453	12	495	1070	493	533
CDXRT-400-5'5	651	796	431.5	507	290	30	300	60	760	507	12	540	1160	547	587
CDXRT-400-7'5	651	796	431.5	507	290	30	300	60	760	507	12	540	1160	547	587
CDXRT-450-5'5	728	887	486	569	322	35	336	60	845	569	12	635	1350	609	649
CDXRT-450-7'5	728	887	486	569	322	35	336	60	845	569	12	635	1350	609	649
CDXRT-450-10	728	887	486	569	322	35	336	60	845	569	12	635	1350	609	649
CDXRT-500-5'5	800	978	538	638	352	35	375	60	915	638	12	635	1350	678	718
CDXRT-500-7'5	800	978	538	638	352	35	375	60	915	638	12	635	1350	678	718
CDXRT-500-10	800	978	538	638	352	35	375	60	915	638	12	635	1350	678	718
CDXRT-500-15	800	978	538	638	352	35	375	60	915	638	12	635	1350	678	718
CDXRT-560-5'5	893	1090	602	715	390	40	420	60	1000	715	12	680	1440	765	815
CDXRT-560-7'5	893	1090	602	715	390	40	420	60	1000	715	12	680	1440	765	815
CDXRT-560-10	893	1090	602	715	390	40	420	60	1000	715	12	680	1440	765	815
CDXRT-560-15	893	1090	602	715	390	40	420	60	1000	715	12	680	1440	765	815
CDXRT-560-20	893	1090	602	715	390	40	420	60	1000	715	12	680	1440	765	815
CDXRT-630-5'5	999	1217	678.5	801	434	45	471.5	60	1090	801	12	745	1570	851	901
CDXRT-630-7'5	999	1217	678.5	801	434	45	471.5	60	1090	801	12	745	1570	851	901
CDXRT-630-10	999	1217	678.5	801	434	45	471.5	60	1090	801	12	745	1570	851	901
CDXRT-630-15	999	1217	678.5	801	434	45	471.5	60	1090	801	12	745	1570	851	901
CDXRT-630-20	999	1217	678.5	801	434	45	471.5	60	1090	801	12	745	1570	851	901
CDXRT-630-25	999	1217	678.5	801	434	45	471.5	60	1090	801	12	745	1570	851	901
CDXRT-630-30	999	1217	678.5	801	434	45	471.5	60	1090	801	12	745	1570	851	901
CDXRT-710-5'5	1121	1363	765	898	485	50	531	60	1255	898	12	860	1800	948	998
CDXRT-710-7'5	1121	1363	765	898	485	50	531	60	1255	898	12	860	1800	948	998
CDXRT-710-10	1121	1363	765	898	485	50	531	60	1255	898	12	860	1800	948	998
CDXRT-710-15	1121	1363	765	898	485	50	531	60	1255	898	12	860	1800	948	998
CDXRT-710-20	1121	1363	765	898	485	50	531	60	1255	898	12	860	1800	948	998
CDXRT-710-25	1121	1363	765	898	485	50	531	60	1255	898	12	860	1800	948	998
CDXRT-710-30	1121	1363	765	898	485	50	531	60	1255	898	12	860	1800	948	998

CJDXR

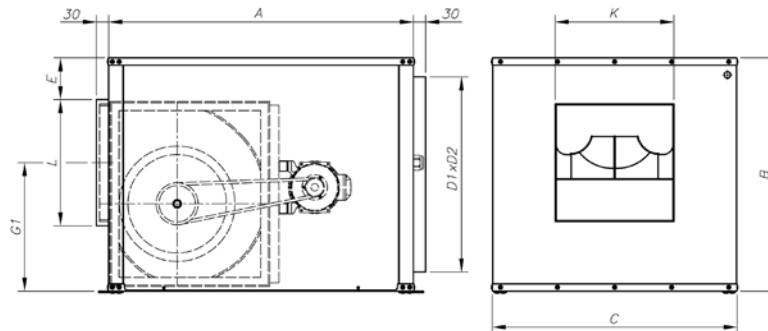

Installation A

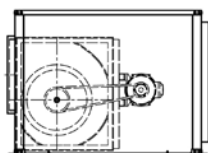

Installation B

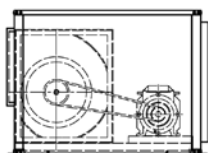

Model	A	B	C	D1xD2	E	G1	LxK
CJDXR-355	1000	755	800	661x706	36.5	484	468.5x468.5
CJDXR-400	1200	875	1000	781x906	58	555.5	522.5x522.5
CJDXR-450	1300	1025	1050	929x956	98	634.5	584.5x584.5
CJDXR-500	1400	1175	1100	1079x1004	157.5	691	635.5x635.5
CJDXR-560	1480	1250	1250	1154x1154	118	766.5	730.5x730.5
CJDXR-630	1660	1375	1450	1279x1354	115	851.5	816.5x816.5
CJDXR-710	1800	1600	1650	1504x1554	194	949	913.5x913.5

Characteristic curves

Q = Airflow in m³/h, m³/s and cfm.

Pe = Static pressure in mm.w.c., Pa and in wg.

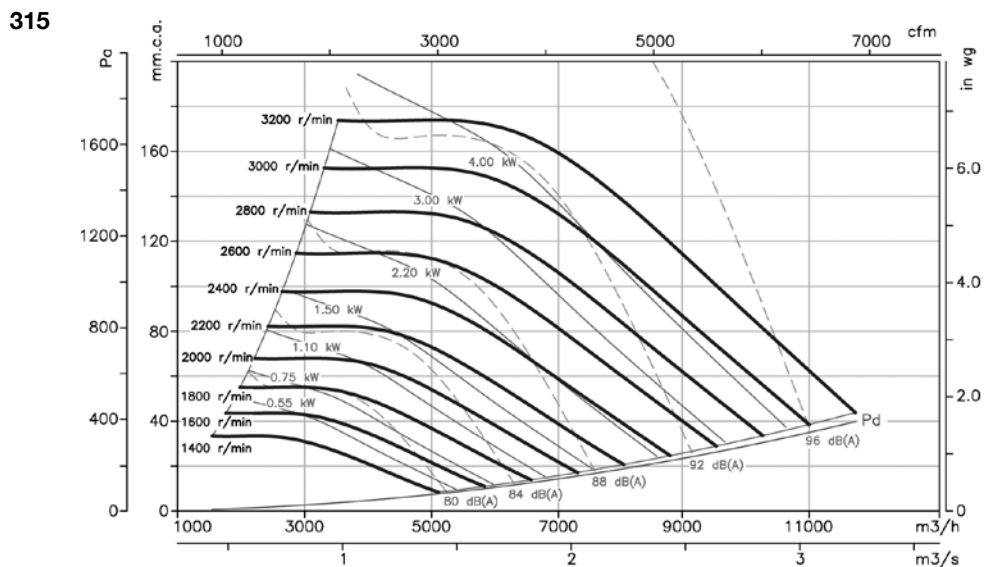
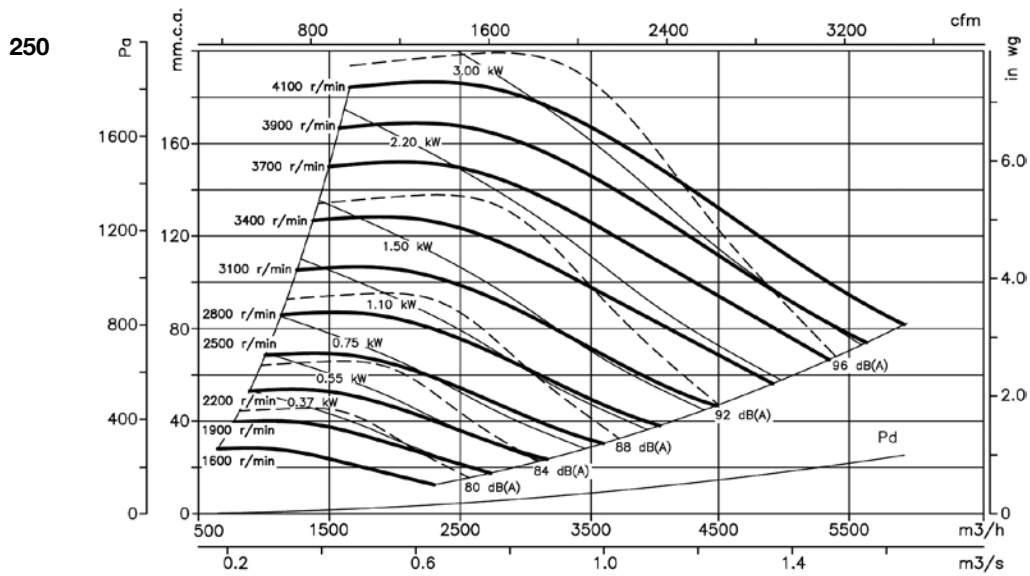
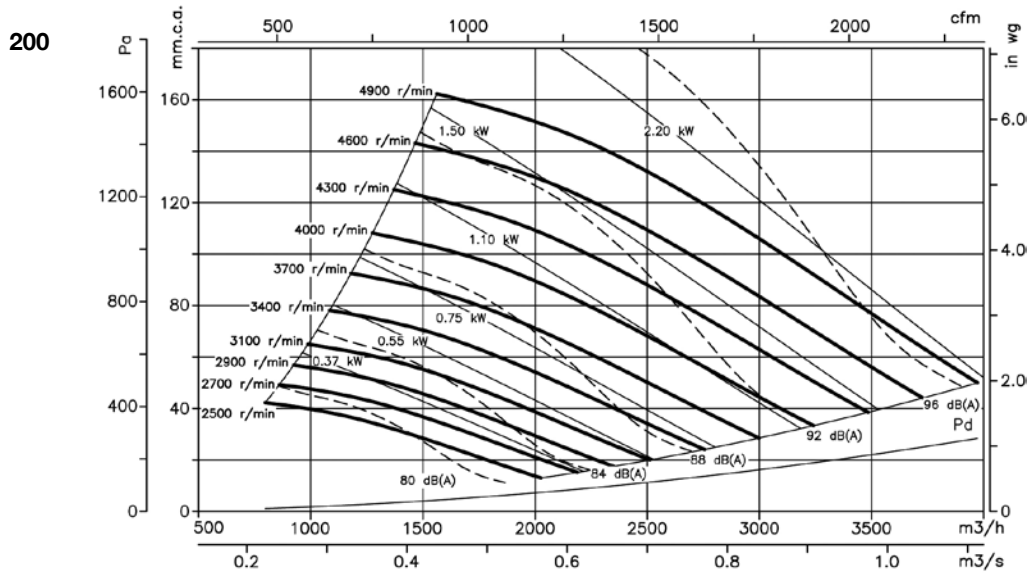

Characteristic curves

Q = Airflow in m³/h, m³/s and cfm.

Pe= Static pressure in mm.w.c., Pa and in wg.

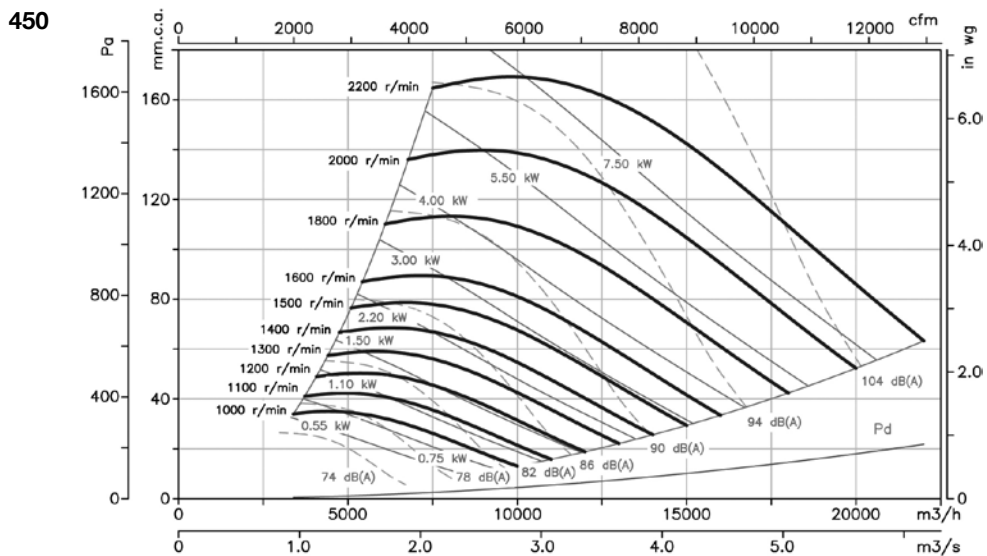
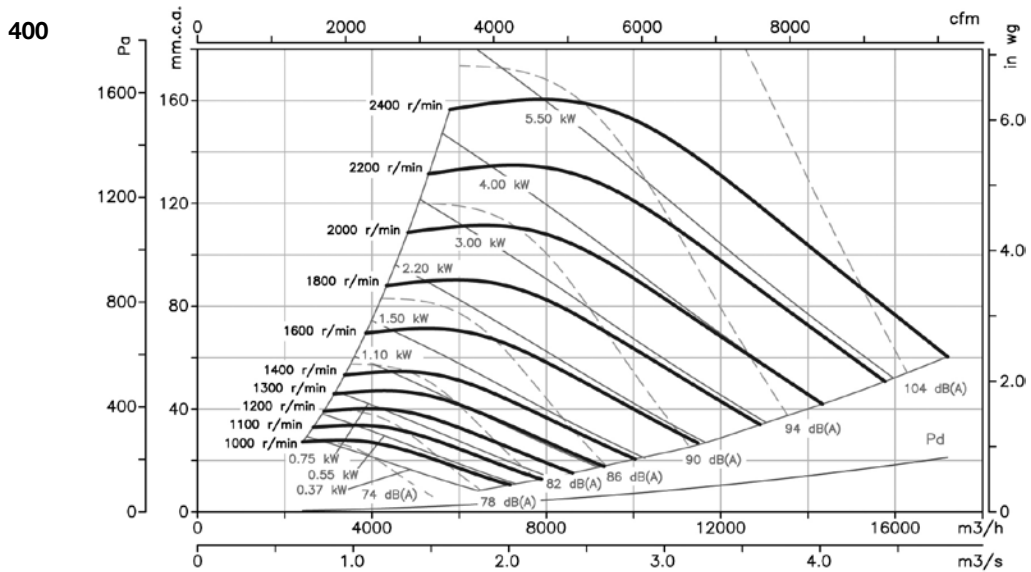
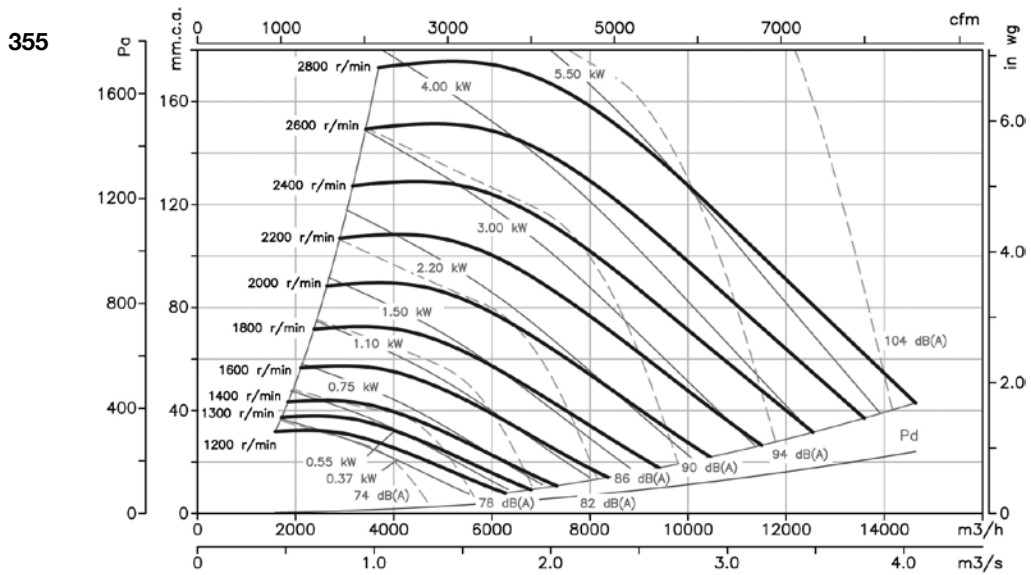

Characteristic curves

Q = Airflow in m³/h, m³/s and cfm.

Pe = Static pressure in mm.w.c., Pa and in wg.

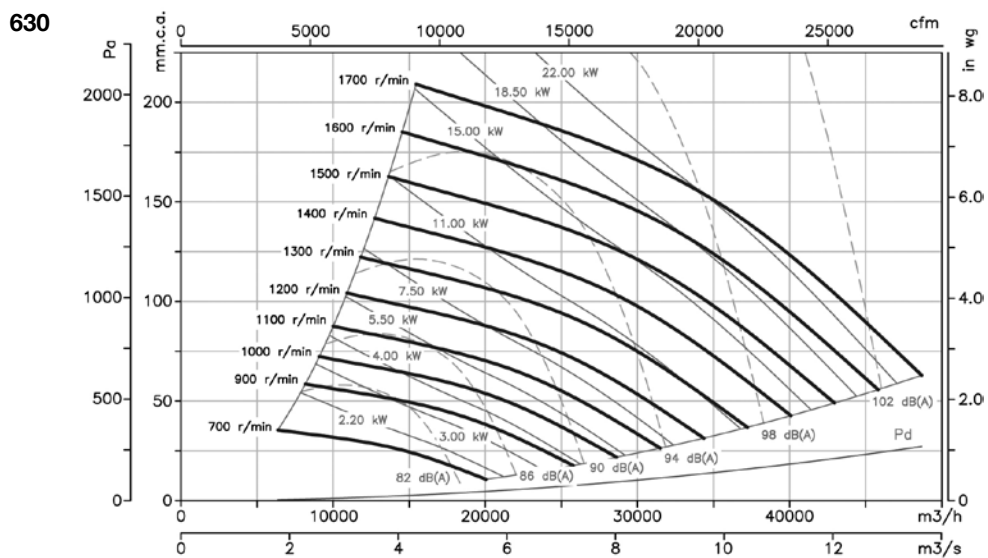
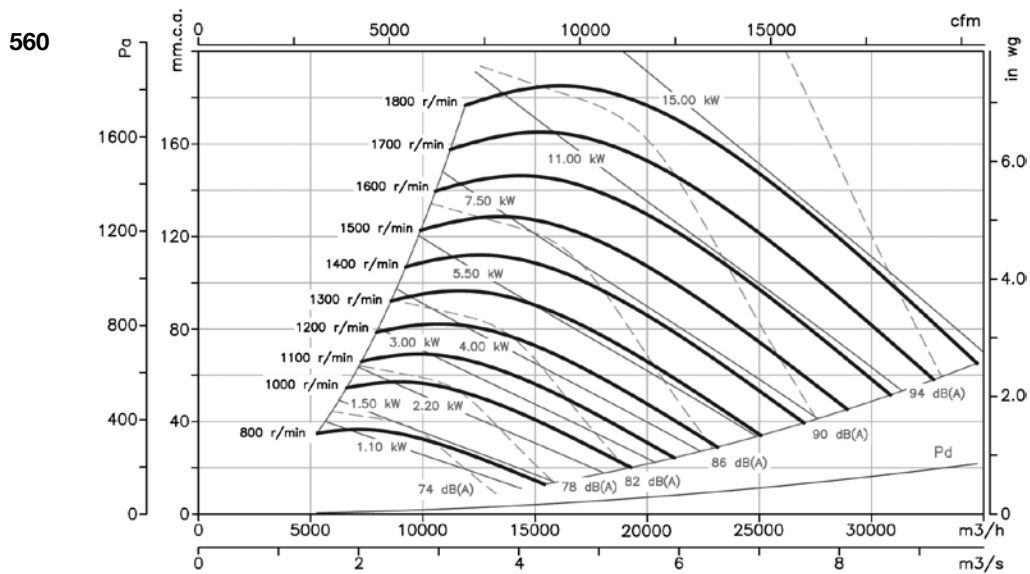
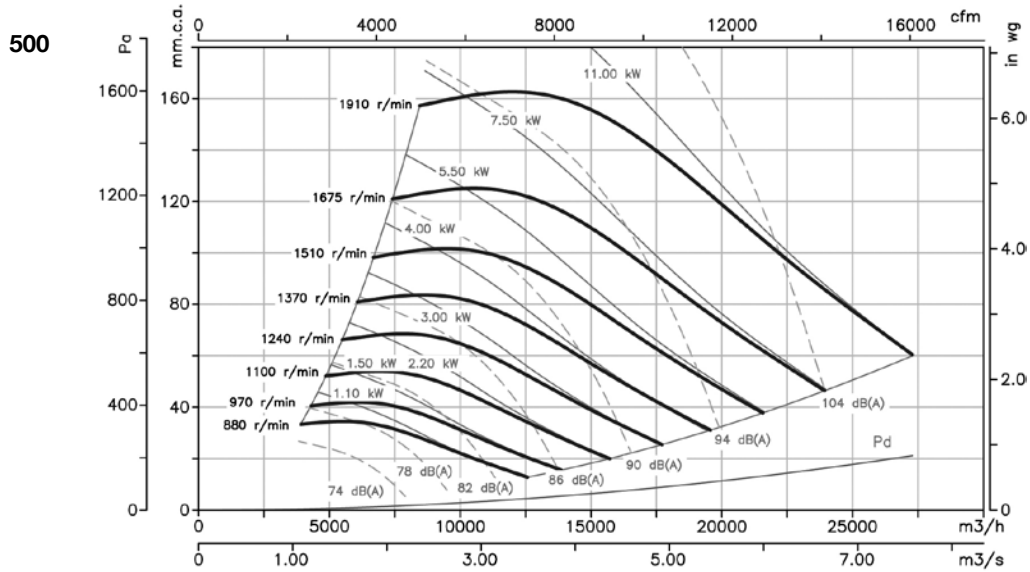

Characteristic curves

Q = Airflow in m³/h, m³/s and cfm.

Pe= Static pressure in mm.w.c., Pa and in wg.

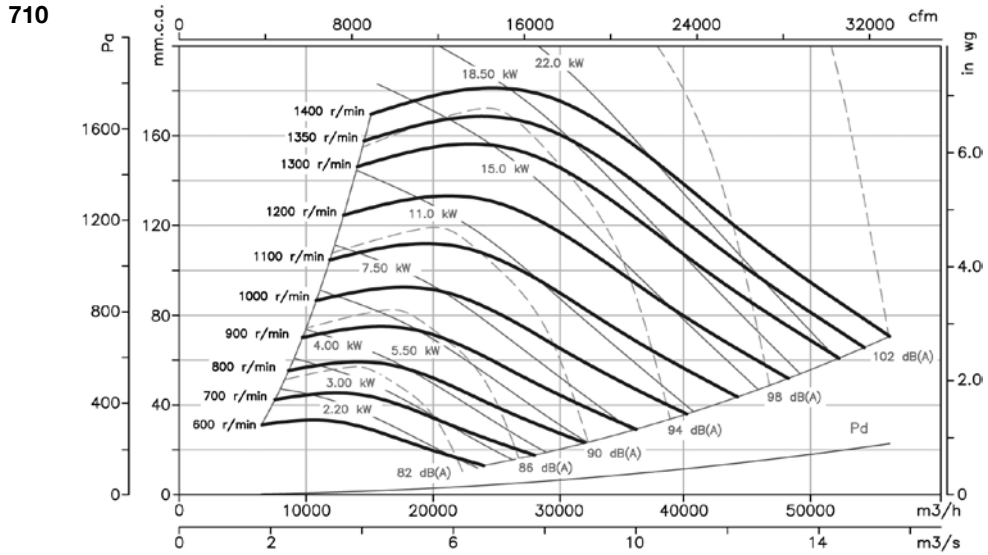

Accessories

See the accessories section.



CSXR CSXRT CJSXR

CSXR: Single-inlet, belt-driven centrifugal fans with axis outlet and impeller with backward-facing blades

CSXRT: Single-inlet, belt-driven centrifugal fans with electric motor, pulley, belt kit and standardised protectors and impeller with backward-facing blades.

CJSXR: Soundproof ventilation units with backward-facing blades, fitted with CSXR series fans on rubber dampers



CSXR



CSXRT



CJSXR

Fan:

- Galvanized sheet steel casing
- Impeller with backward-facing blades made from galvanised sheet steel
- Galvanised sheet steel structure with thermal insulation and soundproofing (CJSXR)
- Stuffing-box for cable input (CJSXR)

Motor:

- Motors with IE-2 efficiency, except for motors with lower powers than 0.75 kW, monophase motors or two-speed motors
- Class F motors with ball bearings, IP55 protection
- Three-phase 230/400V. 50Hz (up to 5.5CV) and 400/690V. 50Hz (power over 5.5CV)
- Max. temperature of air for transport: -20°C. +60°C.

Finish:

- Anticorrosive galvanized sheet steel.

On request:

- Different outlet positions
- Special windings for different voltages
- With two speed motors

Order code

CSXR — 400



CSXR: Centrifugal single-inlet fans with axis outlet

Impeller size

CSXRT — 500 — 4



CSXRT: Centrifugal single-inlet fans with motor

Impeller size

Power motor (c.v.)

CJSXR: Ventilation units with impeller with backward-facing blades

Technical characteristics

Model	Max. Speed (r/min)	Max. installed Power (kW)	Maximum Airflow (m³/h)	Air temperature (°C)		Approx. weight (Kg)
				min.	max.	
CSXR-315	3200	1.1	5050	-20	85	27
CSXR-355	2800	1.5	6650	-20	85	39
CSXR-400	2400	1.5	7700	-20	85	44
CSXR-450	2200	3	10100	-20	85	55
CSXR-500	2200	5.5	14000	-20	85	70
CSXR-560	2000	7.5	18300	-20	85	110
CSXR-630	1600	7.5	19800	-20	85	125
CSXR-710	1400	9.2	25920	-20	85	175
CSXR-800	1600	22	40000	-20	85	252
CSXR-900	1400	30	51000	-20	85	360
CSXR-1000	1400	37	64000	-20	85	445

Technical characteristics

Model			Speed (r/min)	Maximum admissible current (A)			Installed Power (kW)	Maximum Airflow (m³/h)	Approx. weight (Kg)	Assembly Type	
				230V	400V	690V				CSXRT	CJSXR
CSXRT	CJSXR	315-0.75	2520	2.4	1.4	-	0.55	4000	32	A	B
CSXRT	CJSXR	315-1	2800	3.1	1.8	-	0.75	4500	34	A	B
CSXRT	CJSXR	315-1.5	3250	4.4	2.5	-	1.1	5050	36	A	B
CSXRT	CJSXR	355-0.75	2100	2.4	1.4	-	0.55	4750	41	A	B
CSXRT	CJSXR	355-1	2300	3.1	1.8	-	0.75	5200	44	A	B
CSXRT	CJSXR	355-1.5	2600	4.4	2.5	-	1.1	6000	46	A	B
CSXRT	CJSXR	355-2	2875	5.8	3.4	-	1.5	6650	48	A	B
CSXRT	CJSXR	400-0.75	1730	2.4	1.4	-	0.55	5600	49	A	B
CSXRT	CJSXR	400-1	1900	3.3	1.9	-	0.75	6100	52	A	B
CSXRT	CJSXR	400-1.5	2180	4.5	2.6	-	1.1	7000	54	A	B
CSXRT	CJSXR	400-2	2400	5.8	3.4	-	1.5	7700	56	A	B
CSXRT	CJSXR	450-0.75	1230	2.4	1.4	-	0.55	5800	61	A	B
CSXRT	CJSXR	450-1	1380	3.3	1.9	-	0.75	6500	64	A	B
CSXRT	CJSXR	450-1.5	1550	4.5	2.6	-	1.1	7500	66	A	B
CSXRT	CJSXR	450-2	1700	6.0	3.5	-	1.5	8050	68	A	B
CSXRT	CJSXR	450-3	1950	8.4	4.8	-	2.2	9050	72	A	B
CSXRT	CJSXR	450-4	2200	10.4	6.0	-	3	10100	76	A	B
CSXRT	CJSXR	500-1.5	1250	4.5	2.6	-	1.1	8200	88	A	B
CSXRT	CJSXR	500-2	1380	6.0	3.5	-	1.5	9000	90	A	B
CSXRT	CJSXR	500-3	1560	8.4	4.8	-	2.2	10200	93	A	B
CSXRT	CJSXR	500-4	1730	11.3	6.5	-	3	11500	98	A	B
CSXRT	CJSXR	500-5.5	1900	13.9	8.0	-	4	12500	107	A	B
CSXRT	CJSXR	500-7.5	2130	-	11.1	6.4	5.5	14000	116	A	B
CSXRT	CJSXR	560-2	1200	6.0	3.5	-	1.5	11000	100	A	B
CSXRT	CJSXR	560-3	1380	8.4	4.8	-	2.2	12200	103	A	B
CSXRT	CJSXR	560-4	1500	11.3	6.5	-	3	14000	108	A	B
CSXRT	CJSXR	560-5.5	1670	13.9	8.0	-	4	15500	117	A	B
CSXRT	CJSXR	560-7.5	1850	-	11.1	6.4	5.5	16200	122	A	B
CSXRT	CJSXR	560-10	2050	-	14.8	8.6	7.5	18300	132	A	B
CSXRT	CJSXR	630-3	1060	8.4	4.8	-	2.2	13200	119	A	B
CSXRT	CJSXR	630-4	1150	11.3	6.5	-	3	14400	123	A	B
CSXRT	CJSXR	630-5.5	1300	13.9	8.0	-	4	16000	132	A	B
CSXRT	CJSXR	630-7.5	1450	-	11.1	6.4	5.5	18000	138	A	B
CSXRT	CJSXR	630-10	1600	-	14.8	8.6	7.5	19800	147	A	B
CSXRT	CJSXR	710-4	1000	11.3	6.5	-	3	17280	186	A	B
CSXRT	CJSXR	710-5.5	1100	13.9	8.0	-	4	19080	195	A	B
CSXRT	CJSXR	710-7.5	1200	-	11.1	6.4	5.5	20880	200	A	B
CSXRT	CJSXR	710-10	1350	-	14.8	8.6	7.5	23760	210	A	B
CSXRT	CJSXR	710-12.5	1480	-	17.5	10.1	9.2	25920	219	A	B
CSXRT		800-4	800	11.3	6.5	-	3	20800	226	B	
CSXRT		800-5.5	880	13.9	8.0	-	4	22680	234	B	
CSXRT		800-7.5	970	-	11.1	6.4	5.5	25100	240	B	
CSXRT		800-10	1070	-	14.8	8.6	7.5	27720	250	B	
CSXRT		800-12.5	1150	-	17.5	10.1	9.2	30000	259	B	
CSXRT		800-15	1230	-	22.0	12.8	11	32040	284	B	
CSXRT		800-20	1350	-	29.0	16.8	15	34000	305	B	
CSXRT		800-25	1450	-	36.5	21.2	18.5	37800	325	B	
CSXRT		800-30	1540	-	42.0	24.4	22	40000	344	B	
CSXRT		900-4	650	11.3	6.5	-	3	23760	281	B	
CSXRT		900-5.5	720	13.9	8.0	-	4	26000	289	B	
CSXRT		900-7.5	790	-	11.1	6.4	5.5	29500	295	B	
CSXRT		900-10	860	-	14.8	8.6	7.5	32100	305	B	
CSXRT		900-12.5	940	-	17.5	10.1	9.2	34200	314	B	
CSXRT		900-15	1020	-	22.0	12.8	11	37900	339	B	
CSXRT		900-20	1120	-	29.0	16.8	15	42000	360	B	
CSXRT		900-25	1190	-	36.5	21.2	18.5	43500	380	B	
CSXRT		900-30	1250	-	42.0	24.4	22	45500	399	B	
CSXRT		900-40	1400	-	59.0	34.2	30	51000	453	B	
CSXRT		1000-5.5	600	13.9	8.0	-	4	30500	342	B	
CSXRT		1000-7.5	660	-	11.1	6.4	5.5	33000	348	B	
CSXRT		1000-10	730	-	14.8	8.6	7.5	37000	358	B	
CSXRT		1000-12.5	790	-	17.5	10.1	9.2	40000	366	B	
CSXRT		1000-15	840	-	22.0	12.8	11	42500	392	B	
CSXRT		1000-20	940	-	29.0	16.8	15	46000	413	B	
CSXRT		1000-25	1000	-	36.5	21.2	18.5	50000	432	B	
CSXRT		1000-30	1060	-	42.0	24.4	22	52500	452	B	
CSXRT		1000-40	1160	-	59.0	34.2	30	59000	506	B	
CSXRT		1000-50	1260	-	68.0	39.4	37	64000	549	B	

Dimensions in mm

CSXR

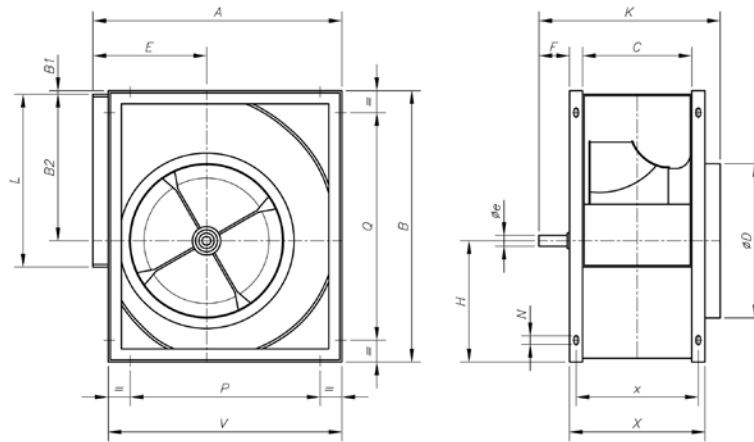

Model	A	B	B1	B2	C	øD	øe	E	F	H	K	L	N	P	Q	V	X	x
CSXR-315	518	578	3	340	223	322	25	236	83	235	395	404	13x18	280	280	480	283	253
CSXR-355	578	655	6	383	247	362	30	261	78	266	425	453	13x18	355	355	548	327	287
CSXR-400	651	736	4.5	431.5	274	404	30	290	78	300	452	507	13x18	355	355	613	354	314
CSXR-450	726	827	5	486	308	448	35	322	92	336	500	569	13x18	530	530	681	388	348
CSXR-500	800	918	5	538	344	510	35	352	92	375	535	638	13x18	530	530	750	424	394
CSXR-560	893	1030	8	602	383	570	40	390	87	420	600	715	13x18	530	530	845	483	433
CSXR-630	999	1157	7	678.5	432	635	45	434	87	471.5	650	801	13x18	530	530	946	532	482
CSXR-710	1121	1303	7	765	478	722	50	485	115	531	725	898	17x22	630	630	1058	578	528

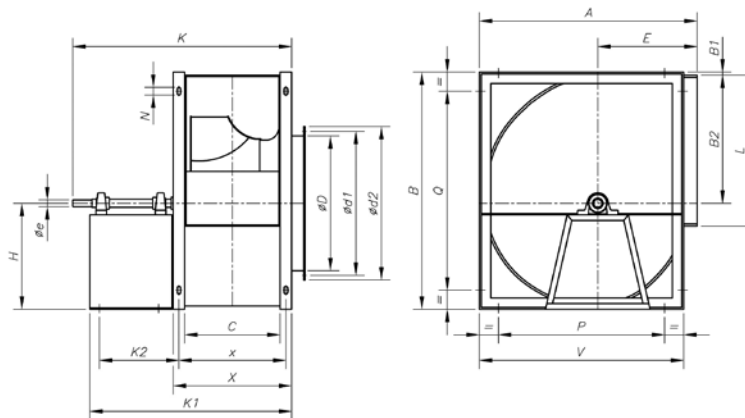

Model	A	B	B1	B2	C	øD	ød1	ød2	øe	E	H	K	K1	K2	L	N	P	Q	V	X	x
CSXR-800	1250	1468	7	862	533	808	844	875	45	535	599	1170	1060	440	1007	17x22	710	710	1181	633	583
CSXR-900	1408	1648	7	971	595	896	945	980	55	604	670	1313	1191	510	1130	17x22	800	800	1319	715	655
CSXR-1000	1541	1810	9	1066	663	996	1044	1080	55	657	735	1381	1259	510	1267	17x22	900	900	1462	783	713

Dimensions in mm

CSXRT
Installation A

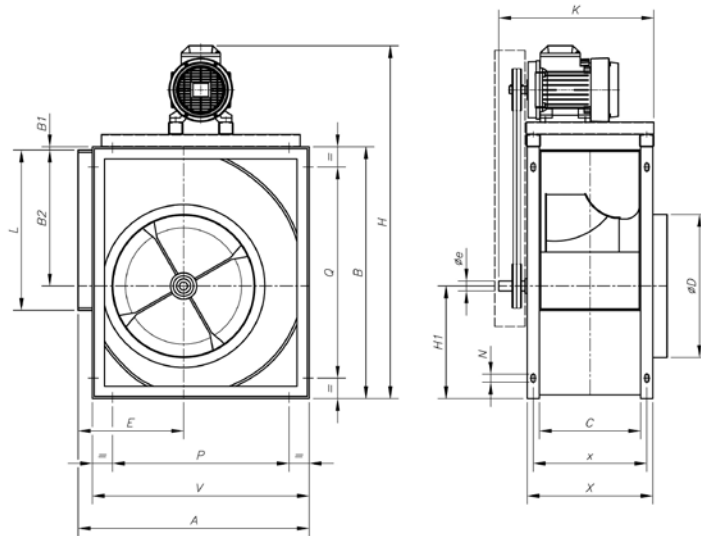

Model	A	B	B1	B2	C	øD	øe	E	H	H1	K	L	N	P	Q	V	X	x
CSXRT-315-0'75	518	578	3	340	223	322	25	236	835	235	395	404	13x18	280	280	480	283	253
CSXRT-315-1	518	578	3	340	223	322	25	236	855	235	395	404	13x19	280	280	480	283	253
CSXRT-315-1'5	518	578	3	340	223	322	25	236	855	235	395	404	13x20	280	280	480	283	253
CSXRT-315-2	518	578	3	340	223	322	25	236	875	235	395	404	13x21	280	280	480	283	253
CSXRT-315-3	518	578	3	340	223	322	25	236	875	235	395	404	13x22	280	280	480	283	253
CSXRT-355-0'75	578	655	6	383	247	362	30	261	910	266	425	453	13x18	355	355	548	327	287
CSXRT-355-1	578	655	6	383	247	362	30	261	930	266	425	453	13x19	355	355	548	327	287
CSXRT-355-1'5	578	655	6	383	247	362	30	261	930	266	425	453	13x20	355	355	548	327	287
CSXRT-355-2	578	655	6	383	247	362	30	261	945	266	425	453	13x21	355	355	548	327	287
CSXRT-355-3	578	655	6	383	247	362	30	261	945	266	425	453	13x22	355	355	548	327	287
CSXRT-355-4	578	655	6	383	247	362	30	261	963	266	425	453	13x23	355	355	548	327	287
CSXRT-400-0'75	651	736	4.5	431.5	274	404	30	290	1012	300	452	507	13x18	355	355	613	354	314
CSXRT-400-1	651	736	4.5	431.5	274	404	30	290	1012	300	452	507	13x19	355	355	613	354	314
CSXRT-400-1'5	651	736	4.5	431.5	274	404	30	290	1012	300	452	507	13x20	355	355	613	354	314
CSXRT-400-2	651	736	4.5	431.5	274	404	30	290	1033	300	452	507	13x21	355	355	613	354	314
CSXRT-400-3	651	736	4.5	431.5	274	404	30	290	1033	300	452	507	13x22	355	355	613	354	314
CSXRT-400-4	651	736	4.5	431.5	274	404	30	290	1045	300	452	507	13x23	355	355	613	354	314
CSXRT-400-5'5	651	736	4.5	431.5	274	404	30	290	1072	300	452	507	13x24	355	355	613	354	314
CSXRT-450-0'75	726	827	5	486	308	448	35	322	1100	336	500	569	13x18	530	530	681	388	348
CSXRT-450-1	726	827	5	486	308	448	35	322	1100	336	500	569	13x19	530	530	681	388	348
CSXRT-450-1'5	726	827	5	486	308	448	35	322	1120	336	500	569	13x20	530	530	681	388	348
CSXRT-450-2	726	827	5	486	308	448	35	322	1120	336	500	569	13x21	530	530	681	388	348
CSXRT-450-3	726	827	5	486	308	448	35	322	1138	336	500	569	13x22	530	530	681	388	348
CSXRT-450-4	726	827	5	486	308	448	35	322	1138	336	500	569	13x23	530	530	681	388	348
CSXRT-450-5'5	726	827	5	486	308	448	35	322	1162	336	500	569	13x24	530	530	681	388	348
CSXRT-450-7'5	726	827	5	486	308	448	35	322	1205	336	500	569	13x25	530	530	681	388	348
CSXRT-450-10	726	827	5	486	308	448	35	322	1205	336	500	569	13x26	530	530	681	388	348
CSXRT-450-12'5	726	827	5	486	308	448	35	322	1205	336	500	569	13x27	530	530	681	388	348
CSXRT-500-1'5	800	918	5	538	344	510	35	352	1214	375	535	638	13x18	530	530	750	424	394
CSXRT-500-2	800	918	5	538	344	510	35	352	1214	375	535	638	13x19	530	530	750	424	394
CSXRT-500-3	800	918	5	538	344	510	35	352	1228	375	535	638	13x20	530	530	750	424	394
CSXRT-500-4	800	918	5	538	344	510	35	352	1228	375	535	638	13x21	530	530	750	424	394
CSXRT-500-5'5	800	918	5	538	344	510	35	352	1255	375	535	638	13x22	530	530	750	424	394
CSXRT-500-7'5	800	918	5	538	344	510	35	352	1292	375	535	638	13x23	530	530	750	424	394
CSXRT-500-10	800	918	5	538	344	510	35	352	1292	375	535	638	13x24	530	530	750	424	394
CSXRT-500-12'5	800	918	5	538	344	510	35	352	1292	375	535	638	13x25	530	530	750	424	394
CSXRT-500-15	800	918	5	538	344	510	35	352	1350	375	535	638	13x26	530	530	750	424	394

Dimensions in mm

CSXRT-560-2	893	1030	8	602	383	570	40	390	1325	420	600	715	13x18	530	530	845	483	433
CSXRT-560-3	893	1030	8	602	383	570	40	390	1340	420	600	715	13x19	530	530	845	483	433
CSXRT-560-4	893	1030	8	602	383	570	40	390	1340	420	600	715	13x20	530	530	845	483	433
CSXRT-560-5'5	893	1030	8	602	383	570	40	390	1365	420	600	715	13x21	530	530	845	483	433
CSXRT-560-7'5	893	1030	8	602	383	570	40	390	1410	420	600	715	13x22	530	530	845	483	433
CSXRT-560-10	893	1030	8	602	383	570	40	390	1410	420	600	715	13x23	530	530	845	483	433
CSXRT-560-12'5	893	1030	8	602	383	570	40	390	1410	420	600	715	13x24	530	530	845	483	433
CSXRT-560-15	893	1030	8	602	383	570	40	390	1464	420	600	715	13x25	530	530	845	483	433
CSXRT-630-3	999	1157	7	678.5	432	635	45	434	1470	471.5	650	801	13x18	530	530	946	532	482
CSXRT-630-4	999	1157	7	678.5	432	635	45	434	1470	471.5	650	801	13x19	530	530	946	532	482
CSXRT-630-5'5	999	1157	7	678.5	432	635	45	434	1492	471.5	650	801	13x20	530	530	946	532	482
CSXRT-630-7'5	999	1157	7	678.5	432	635	45	434	1531	471.5	650	801	13x21	530	530	946	532	482
CSXRT-630-10	999	1157	7	678.5	432	635	45	434	1531	471.5	650	801	13x22	530	530	946	532	482
CSXRT-630-12'5	999	1157	7	678.5	432	635	45	434	1531	471.5	650	801	13x23	530	530	946	532	482
CSXRT-630-15	999	1157	7	678.5	432	635	45	434	1590	471.5	650	801	13x24	530	530	946	532	482
CSXRT-630-20	999	1157	7	678.5	432	635	45	434	1590	471.5	650	801	13x25	530	530	946	532	482
CSXRT-710-4	1121	1303	7	765	478	722	50	485	1612	531	725	898	17x22	630	630	1058	578	528
CSXRT-710-5'5	1121	1303	7	765	478	722	50	485	1638	531	725	898	17x23	630	630	1058	578	528
CSXRT-710-7'5	1121	1303	7	765	478	722	50	485	1675	531	725	898	17x24	630	630	1058	578	528
CSXRT-710-10	1121	1303	7	765	478	722	50	485	1675	531	725	898	17x25	630	630	1058	578	528
CSXRT-710-12'5	1121	1303	7	765	478	722	50	485	1675	531	725	898	17x26	630	630	1058	578	528
CSXRT-710-15	1121	1303	7	765	478	722	50	485	1735	531	725	898	17x27	630	630	1058	578	528
CSXRT-710-20	1121	1303	7	765	478	722	50	485	1735	531	725	898	17x28	630	630	1058	578	528
CSXRT-710-25	1121	1303	7	765	478	722	50	485	1820	531	725	898	17x29	630	630	1058	578	528

CSXRT Installation B

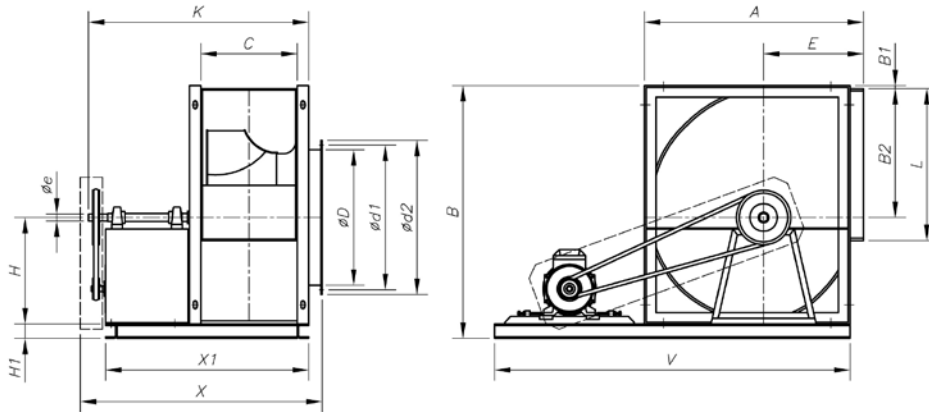

Model	A	B	B1	B2	C	øD	ød1	ød2	øe	E	H	H1	K	L	V	X	X1
CSXRT-800	1250	1548	7	862	533	808	844	875	45	535	599	80	1170	1007	1880	1245	1060
CSXRT-900	1408	1728	7	971	595	896	945	980	55	604	670	80	1313	1130	2050	1375	1291
CSXRT-1000	1541	1890	9	1066	663	996	1044	1080	55	657	735	80	1381	1267	2250	1450	1259

Dimensions in mm

CJSXR

Standard supply horizontal outlet (H) RD90

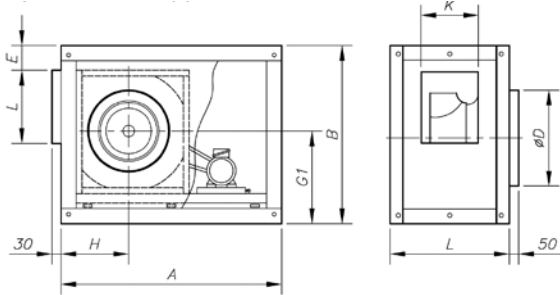

On request horizontal outlet (H) LG 90

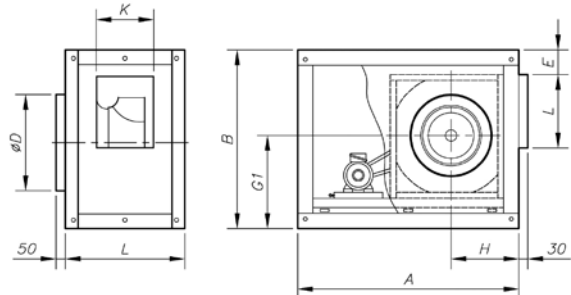

On request vertical outlet (V) LG 0

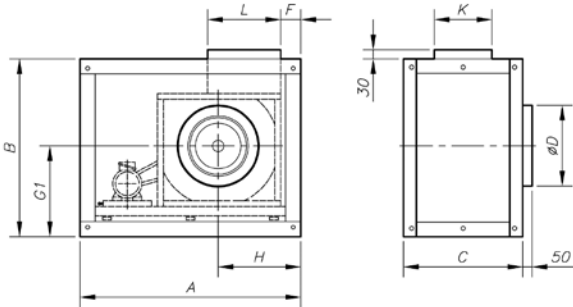

On request vertical outlet (V) RD 0

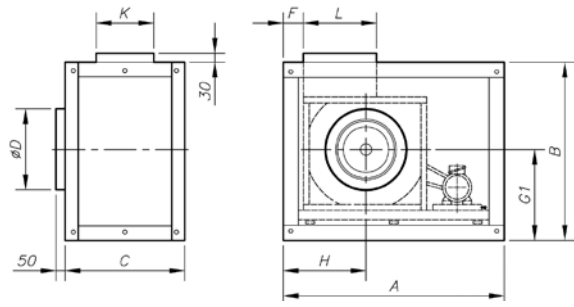

Model	A	B	C	ØD	E	F	G1	H	L	K
CJSXR-315-H	853	710	543	315	70	-	298	259.5	409	228
CJSXR-315-V	950	675	543	315	-	62	345	404.5	409	228
CJSXR-355-H	1000	785	573	365	70	-	329	292.5	458	252
CJSXR-355-V	1078	740	573	365	-	65	380	450.5	458	252
CJSXR-400-H	1200	875	583	405	77	-	363	313.5	514	280
CJSXR-400-V	1120	805	583	405	-	65	424	497.5	514	280
CJSXR-450-H	1200	955	623	450	67	-	399	338.5	575	314
CJSXR-450-V	1355	875	623	450	-	63.5	467	552.5	575	314
CJSXR-500-H	1300	1100	680	515	121	-	438	363.5	644	350
CJSXR-500-V	1430	940	680	515	-	63.5	511	604.5	644	350
CJSXR-560-H	1400	1250	736	575	162	-	483	403.5	721	390
CJSXR-560-V	1590	1070	736	575	-	66.5	566	671.5	721	390
CJSXR-630-H	1500	1380	786	640	162	-	527.5	442.5	807	438
CJSXR-630-V	1720	1170	786	640	-	65.5	630	756	807	438
CJSXR-410-H	1800	1525	860	725	161	-	596	523.5	904	484
CJSXR-710-V	1925	1285	860	725	-	65.5	701	833.5	904	484

Characteristic curves

Q = Airflow in m³/h, m³/s and cfm.

Pe = Static pressure in mm.w.c., Pa and in wg.

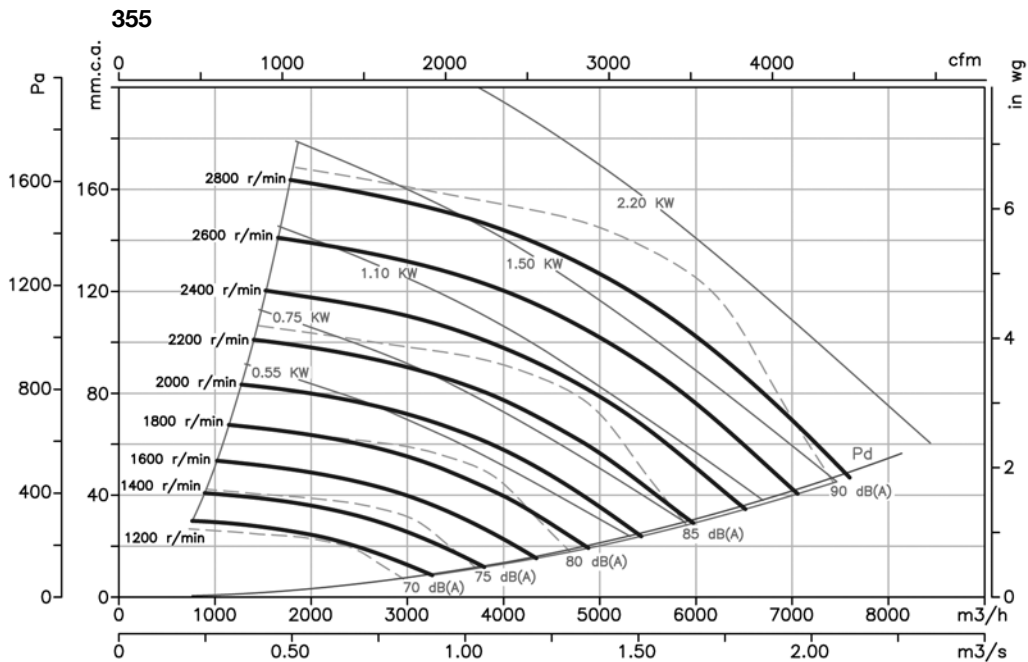
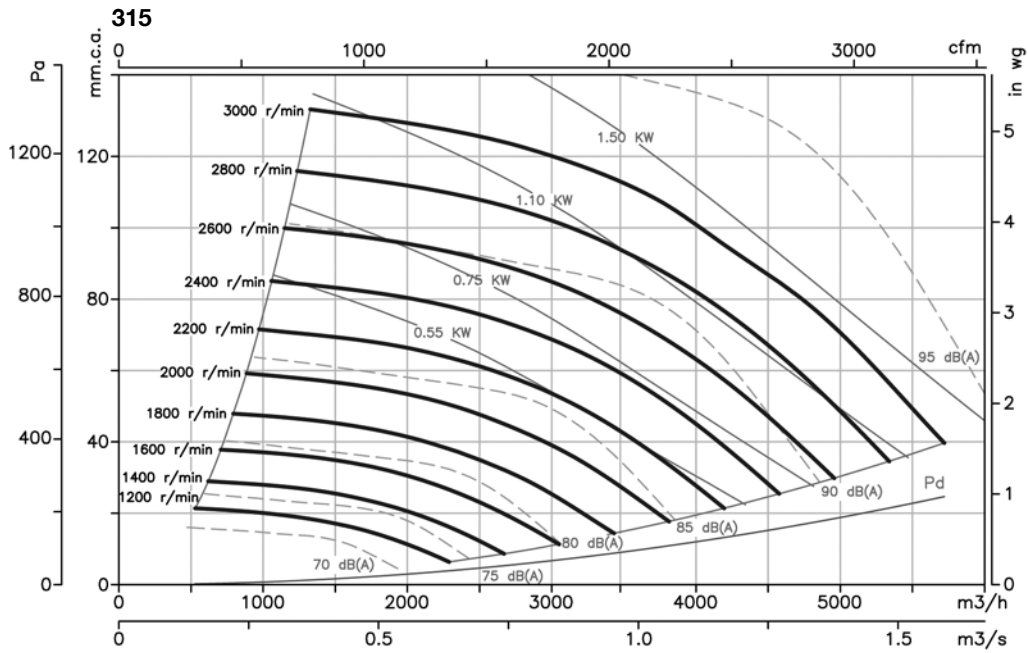

Characteristic curves

Q = Airflow in m³/h, m³/s and cfm.

Pe = Static pressure in mm.w.c., Pa and in wg.

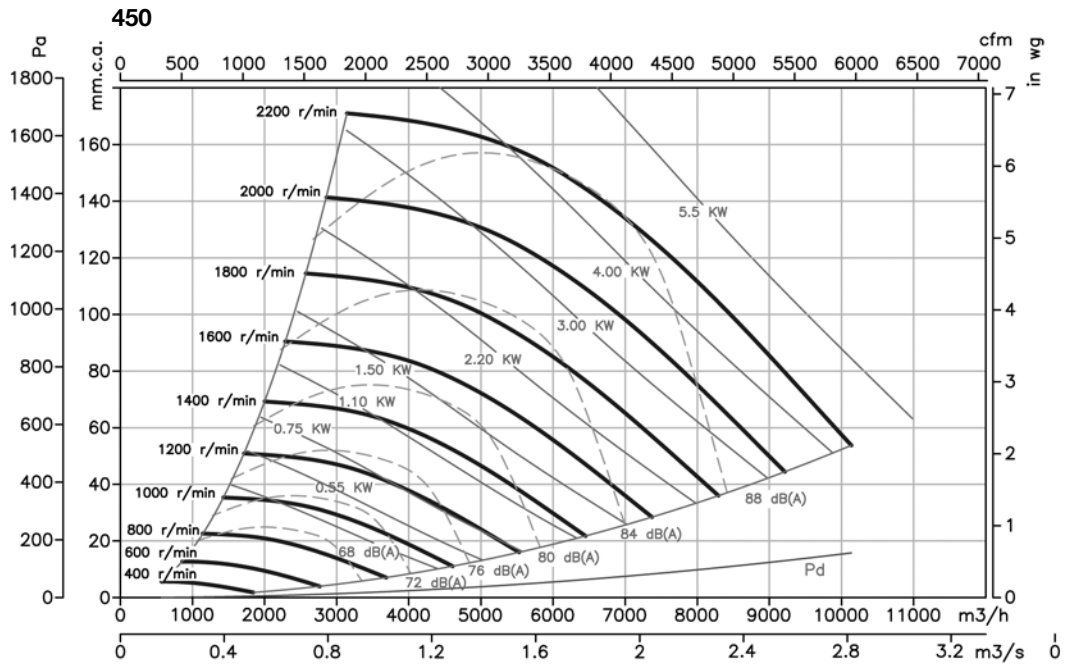
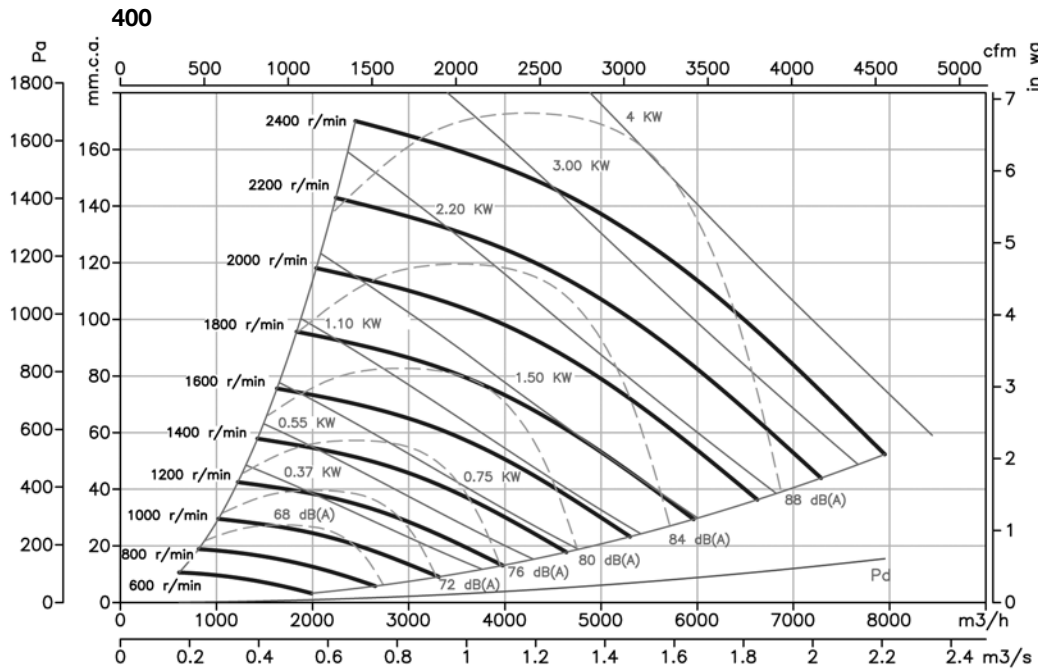

Characteristic curves

Q = Airflow in m³/h, m³/s and cfm.

Pe = Static pressure in mm.w.c., Pa and in wg.

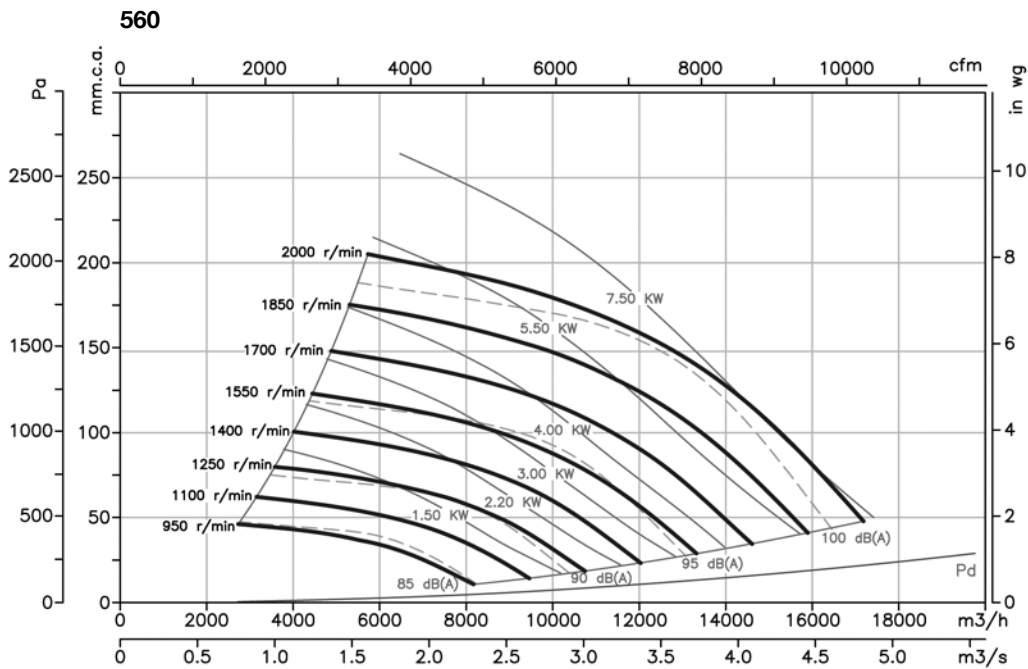
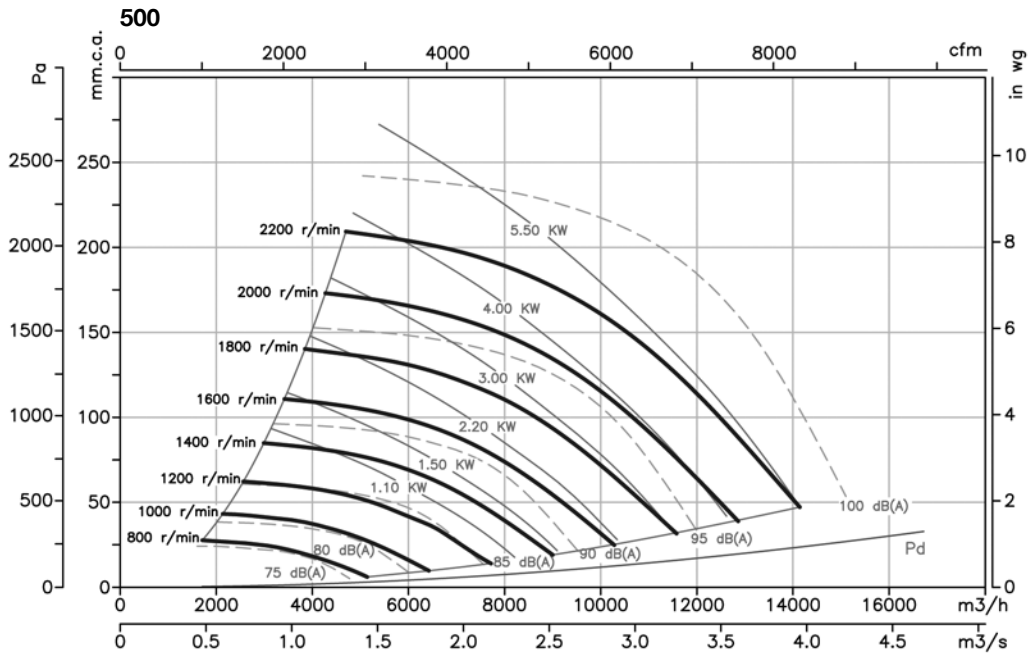

Characteristic curves

Q = Airflow in m³/h, m³/s and cfm.

Pe = Static pressure in mm.w.c., Pa and in wg.

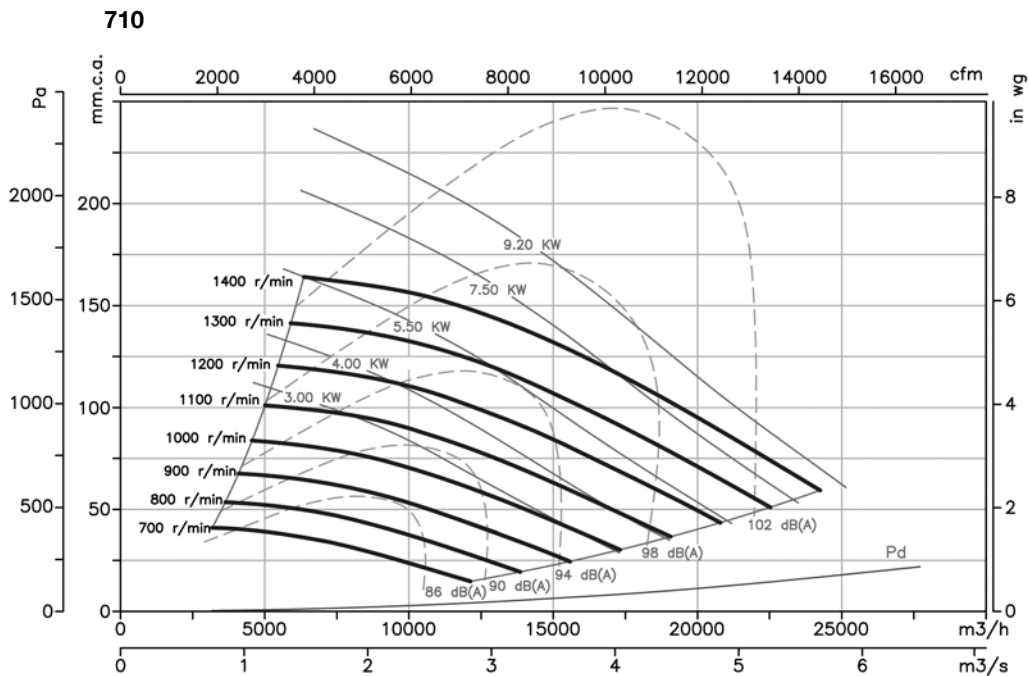
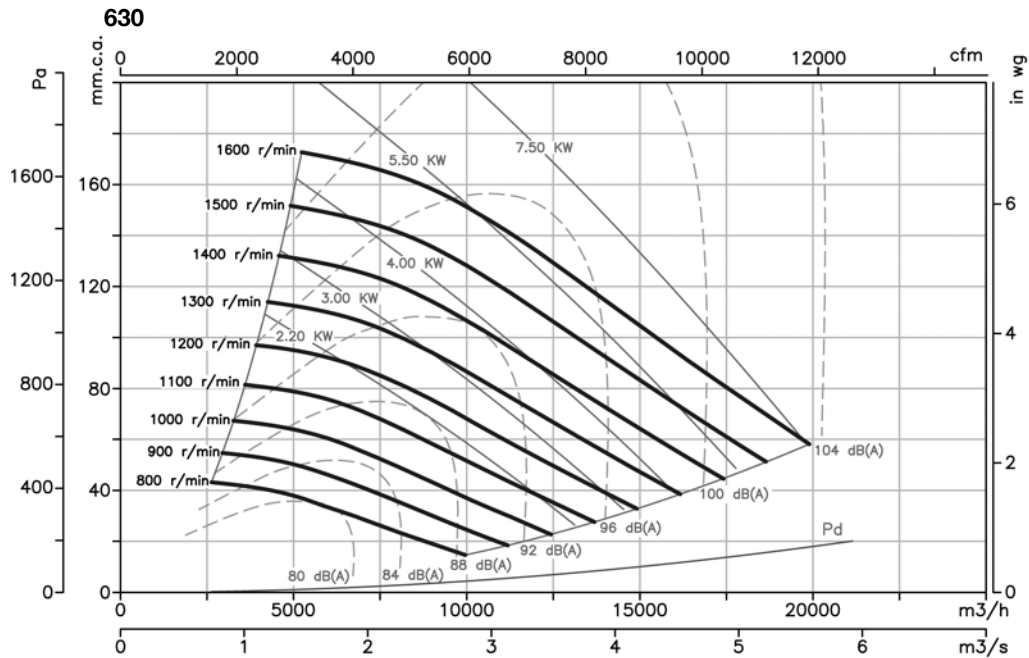

Characteristic curves

Q = Airflow in m³/h, m³/s and cfm.

Pe = Static pressure in mm.w.c., Pa and in wg.

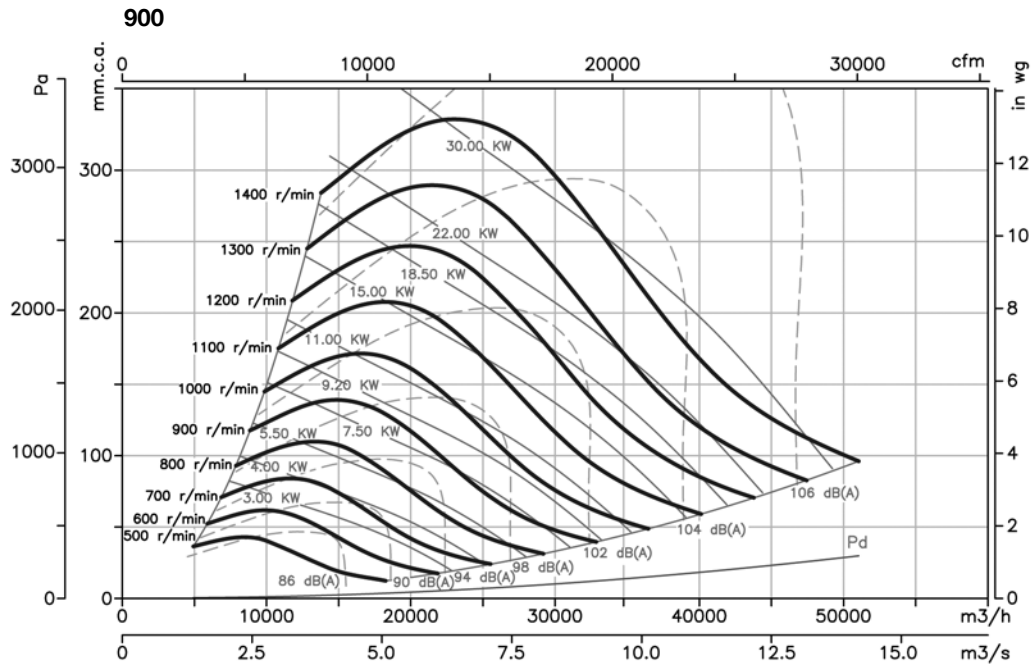
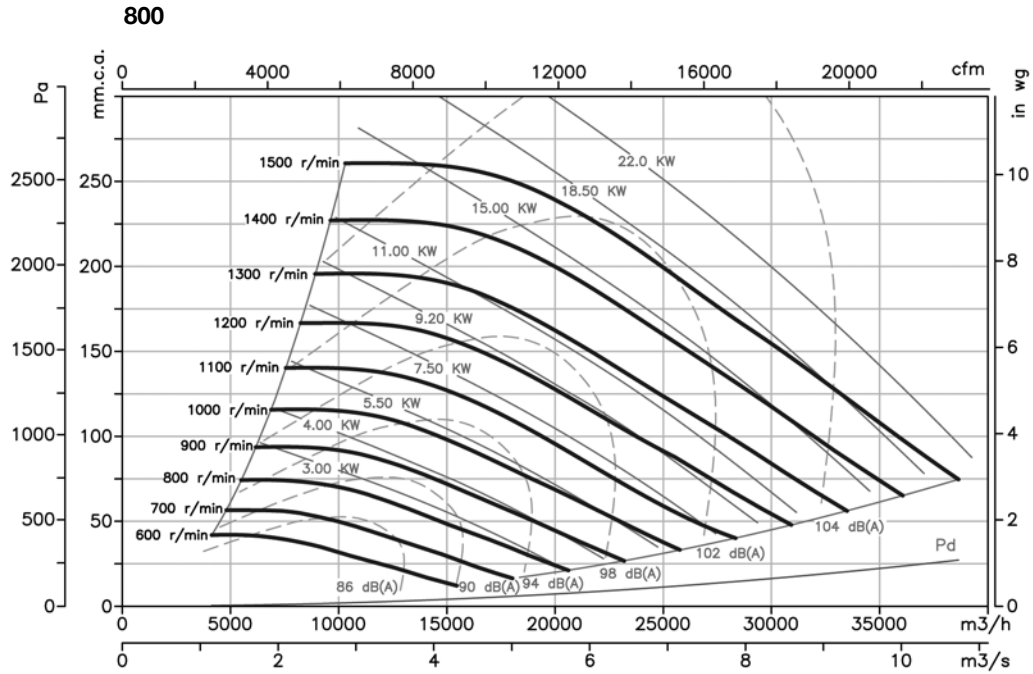

Characteristic curves

Q = Airflow in m³/h, m³/s and cfm.

Pe = Static pressure in mm.w.c., Pa and in wg.

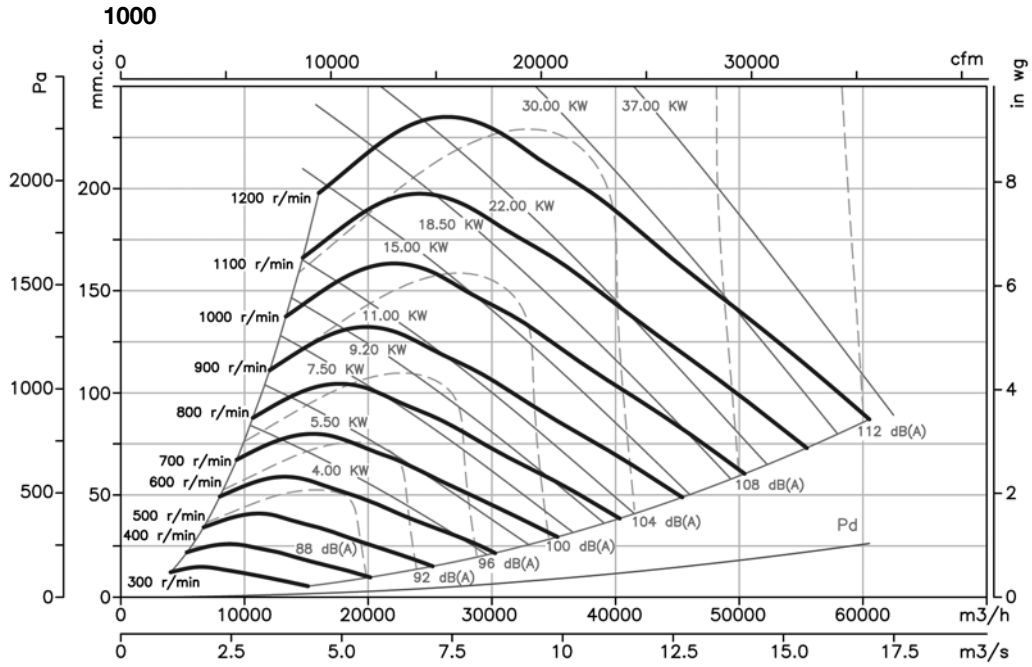

Accessories

See the accessories section.



TSA TSAT CJTSA

TSA: Single-inlet, belt-driven centrifugal fans with axis outlet and impeller with forward-facing blades

TSAT: Single-inlet, belt-driven centrifugal fans with electric motor, pulley, belt kit and standardised protectors and impeller with backward-facing blades.

CJTSA: Soundproof ventilation units with forward-facing blades, fitted with TSA series fans on rubber dampers



TSA



TSAT



CJTSA

Fan:

- Galvanized sheet steel casing
- Impeller with forward-facing blades made from galvanised sheet steel
- Galvanised sheet steel structure with thermal insulation and soundproofing (CJTSA)
- Stuffing-box for cable input (CJTSA)

Motor:

- Motors with IE-2 efficiency, except for motors with lower powers than 0.75 kW, monophase motors or two-speed motors
- Class F motors with ball bearings, IP55 protection
- Three-phase 230/400V, 50Hz (up to 5.5CV) and 400/690V, 50Hz (power over 5.5CV)
- Max. temperature of air for transport: -20°C. +60°C.

Finish:

- Anticorrosive galvanized sheet steel.

On request:

- Different outlet positions
- Special windings for different voltages
- With two speed motors

Order code

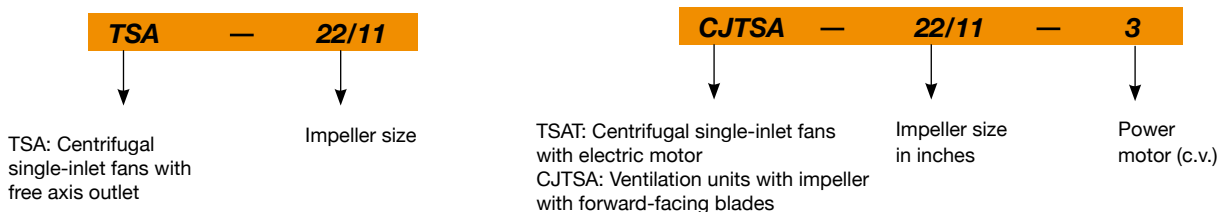

Technical characteristics

Model	Max. Speed (r/min)	Max. installed Power (kW)	Maximum Airflow (m³/h)	Air temperature (°C)		Approx. weight (Kg)
				min.	max.	
TSA-12/6	1500	2.2	4800	-20	85	17.5
TSA-15/7	1050	3	7400	-20	85	22.5
TSA-18/9	920	4	10500	-20	85	33
TSA-20/10	850	5.5	15000	-20	85	71
TSA-22/11	1000	18.5	26000	-20	85	80
TSA-25/13	810	18.5	32000	-20	85	93
TSA-30/14	600	18.5	38000	-20	85	125

Technical characteristics

Model	Speed (r/min)	Maximum admissible current (A)			Installed Power (kW)	Maximum Airflow (m³/h)	Sound pressure level dB(A)	Approx. weight (Kg)
		230V	400V	690V				
TSAT CJTSA 12/6-0.75	1000	2.4	1.4		0.55	2600	69	73
TSAT CJTSA 12/6-1	1100	3.3	1.9		0.75	3100	71	74
TSAT CJTSA 12/6-1.5	1250	4.5	2.6		1.1	3500	74	77
TSAT CJTSA 12/6-2	1300	6.0	3.5		1.5	4250	77	80
TSAT CJTSA 12/6-3	1500	8.3	4.8		2.2	4800	79	85
TSAT CJTSA 15/7-1	800	3.3	1.9		0.75	4000	67	92
TSAT CJTSA 15/7-1.5	850	4.5	2.6		1.1	4800	69	95
TSAT CJTSA 15/7-2	920	6.0	3.5		1.5	5400	72	98
TSAT CJTSA 15/7-3	1000	8.3	4.8		2.2	6400	75	103
TSAT CJTSA 15/7-4	1050	11.2	6.5		3	7400	77	106
TSAT CJTSA 18/9-1.5	750	4.5	2.6		1.1	5800	68	111
TSAT CJTSA 18/9-2	790	6.0	3.5		1.5	6600	70	114
TSAT CJTSA 18/9-3	800	8.3	4.8		2.2	8200	74	119
TSAT CJTSA 18/9-4	850	11.2	6.5		3	9000	76	122
TSAT CJTSA 18/9-5.5	920	14.9	8.6		4	10500	78	125
TSAT CJTSA 20/10-2	650	6.0	3.5		1.5	8100	65	203
TSAT CJTSA 20/10-3	690	8.3	4.8		2.2	10100	68	208
TSAT CJTSA 20/10-4	750	11.2	6.5		3	11500	70	211
TSAT CJTSA 20/10-5.5	790	14.9	8.6		4	13100	73	214
TSAT CJTSA 20/10-7.5	850		11.1	6.4	5.5	15000	75	227
TSAT CJTSA 22/11-3	580	8.3	4.8		2.2	11200	67	219
TSAT CJTSA 22/11-4	610	11.2	6.5		3	13000	70	222
TSAT CJTSA 22/11-5.5	650	14.9	8.6		4	15000	72	225
TSAT CJTSA 22/11-7.5	690		11.1	6.4	5.5	17000	74	238
TSAT CJTSA 22/11-10	750		14.8	8.5	7.5	19000	76	246
TSAT CJTSA 22/11-12.5	790		17.8	10.3	9.2	21000	78	257
TSAT CJTSA 22/11-15	830		21.5	12.4	11	22000	79	273
TSAT CJTSA 22/11-20	910		28.5	16.5	15	24500	81	292
TSAT CJTSA 22/11-25	1000		35.0	20.2	18.5	26000	83	322
TSAT CJTSA 25/13-4	520	11.2	6.5		3	14000	62	254
TSAT CJTSA 25/13-5.5	550	14.9	8.6		4	17000	65	257
TSAT CJTSA 25/13-7.5	590		11.1	6.4	5.5	19500	67	270
TSAT CJTSA 25/13-10	620		14.8	8.5	7.5	23000	70	278
TSAT CJTSA 25/13-12.5	650		17.8	10.3	9.2	25000	72	289
TSAT CJTSA 25/13-15	690		21.5	12.4	11	26500	74	305
TSAT CJTSA 25/13-20	750		28.5	16.5	15	29500	75	324
TSAT CJTSA 25/13-25	810		35.0	20.2	18.5	32000	77	354
TSAT CJTSA 30/14-5.5	400	14.9	8.6		4	21000	69	331
TSAT CJTSA 30/14-7.5	425		11.1	6.4	5.5	24000	72	344
TSAT CJTSA 30/14-10	460		14.8	8.5	7.5	27500	74	352
TSAT CJTSA 30/14-12.5	480		17.8	10.3	9.2	30000	76	363
TSAT CJTSA 30/14-15	500		21.5	12.4	11	33000	77	379
TSAT CJTSA 30/14-20	550		28.5	16.5	15	36500	78	398
TSAT CJTSA 30/14-25	600		35.0	20.2	18.5	38000	81	428

Dimensions in mm

TSA

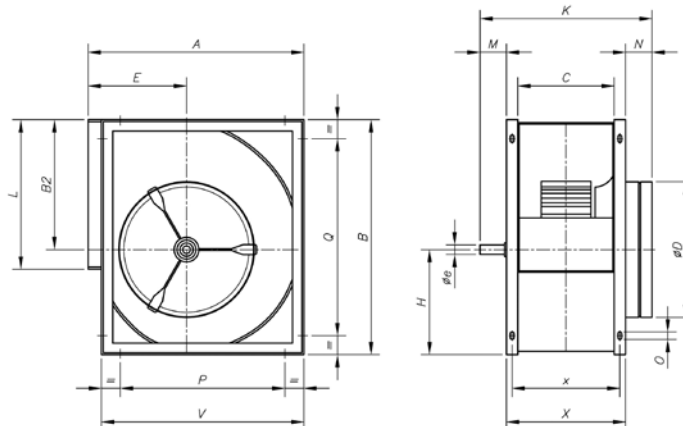

Model	A	B	B2	C	øD	E	øe	H	K	L	M	N	O	P	Q	V	X	x
TSA-12/6	498	532	290	210	325	230	25	242	435	345	75	90	9x17	324	324	468	270	242
TSA-15/7	583	632	348	269	400	265	25	284	494	404	75	90	9x17	406	406	553	329	301
TSA-18/9	694	756	415	301	475	323	25	341	526	482	75	90	9x17	520	608	664	361	333

Dimensions in mm

TSA

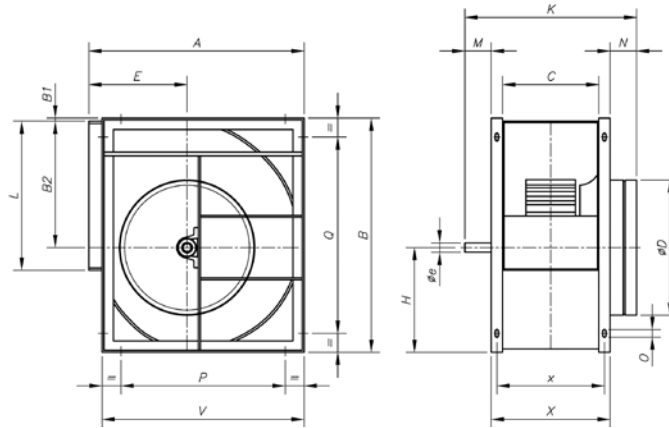

Model	A	B	B1	B2	C	øD	E	øe	H	K	L	M	N	O	P	Q	V	X	x
TSA-20/10	843	963	35	523	330	575	375	35	440	620	603	100	110	9x17	646	811	798	410	370
TSA-22/11	913	1046	35	569	358	615	400	35	477	648	693	100	110	9x17	716	894	868	438	398
TSA-25/13	998	1161	35	642	412	695	423	35	519	701	793	100	110	9x17	801	1009	953	492	452
TSA-30/14	1206	1400	35	776	474	835	515	40	624	764	933	100	110	9x17	1009	1248	1161	554	514

TSAT

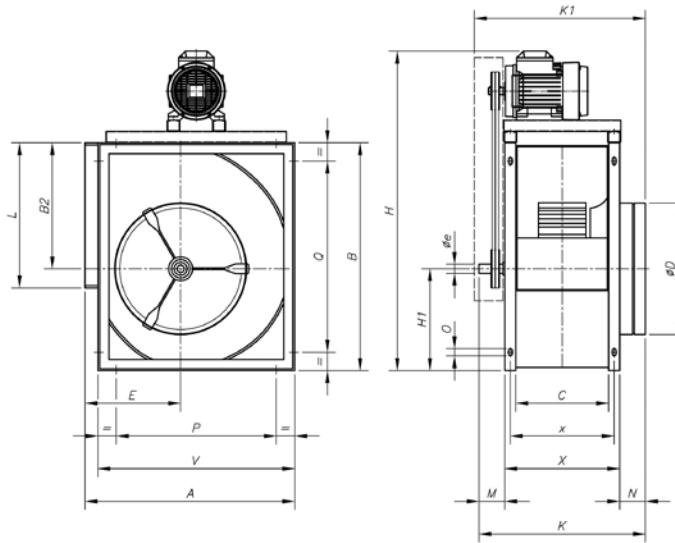

Model	A	B	B2	C	øD	E	øe	H	H1	K	K1	L	M	N	O	P	Q	V	X	x
TSAT-12/6-0'75	498	532	290	210	325	230	25	805	242	435	475	345	75	90	9x17	324	324	468	270	242
TSAT-12/6-1	498	532	290	210	325	230	25	805	242	435	475	345	75	90	9x17	324	324	468	270	242
TSAT-12/6-1'5	498	532	290	210	325	230	25	825	242	435	475	345	75	90	9x17	324	324	468	270	242
TSAT-12/6-2	498	532	290	210	325	230	25	825	242	435	475	345	75	90	9x17	324	324	468	270	242
TSAT-12/6-3	498	532	290	210	325	230	25	845	242	435	475	345	75	90	9x17	324	324	468	270	242
TSAT-15/7-1	583	632	348	269	400	265	25	905	284	494	535	404	75	90	9x17	406	406	553	329	301
TSAT-15/7-1'5	583	632	348	269	400	265	25	925	284	494	535	404	75	90	9x17	406	406	553	329	301
TSAT-15/7-2	583	632	348	269	400	265	25	925	284	494	535	404	75	90	9x17	406	406	553	329	301
TSAT-15/7-3	583	632	348	269	400	265	25	945	284	494	535	404	75	90	9x17	406	406	553	329	301
TSAT-15/7-4	583	632	348	269	400	265	25	945	284	494	535	404	75	90	9x17	406	406	553	329	301
TSAT-18/9-1'5	694	756	415	301	475	323	25	1050	341	526	566	482	75	90	9x17	520	608	664	361	333
TSAT-18/9-2	694	756	415	301	475	323	25	1050	341	526	566	482	75	90	9x17	520	608	664	361	333
TSAT-18/9-3	694	756	415	301	475	323	25	1070	341	526	566	482	75	90	9x17	520	608	664	361	333
TSAT-18/9-4	694	756	415	301	475	323	25	1070	341	526	566	482	75	90	9x17	520	608	664	361	333
TSAT-18/9-5'5	694	756	415	301	475	323	25	1095	341	526	566	482	75	90	9x17	520	608	664	361	333

Dimensions in mm

TSAT

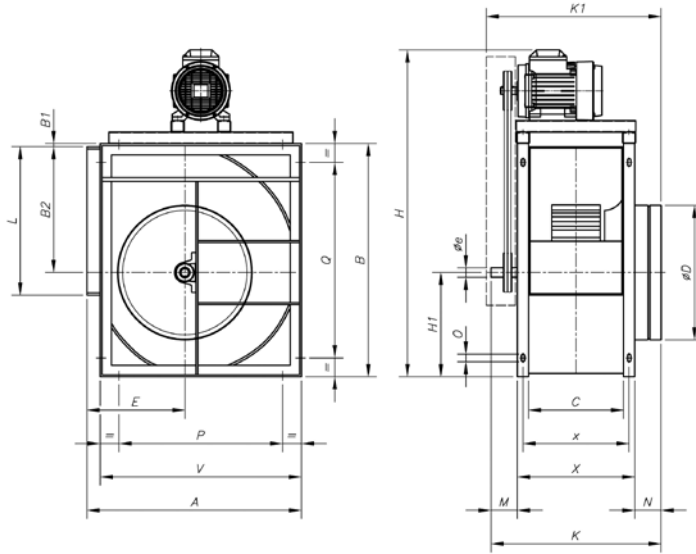

Model	A	B	B1	B2	C	øD	E	øe	H	H1	K	K1	L	M	N	O	P	Q	V	X	x
TSAT-20/10-2	843	963	35	523	330	575	375	35	1255	440	620	670	603	100	110	9x17	646	811	798	410	370
TSAT-20/10-3	843	963	35	523	330	575	375	35	1275	440	620	670	603	100	110	9x17	646	811	798	410	370
TSAT-20/10-4	843	963	35	523	330	575	375	35	1275	440	620	670	603	100	110	9x17	646	811	798	410	370
TSAT-20/10-5'5	843	963	35	523	330	575	375	35	1300	440	620	670	603	100	110	9x17	646	811	798	410	370
TSAT-20/10-7'5	843	963	35	523	330	575	375	35	1340	440	620	670	603	100	110	9x17	646	811	798	410	370
TSAT-22/11-3	913	1046	35	569	358	615	400	35	1355	477	648	700	693	100	110	9x17	716	894	868	438	398
TSAT-22/11-4	913	1046	35	569	358	615	400	35	1355	477	648	700	693	100	110	9x17	716	894	868	438	398
TSAT-22/11-5'5	913	1046	35	569	358	615	400	35	1280	477	648	700	693	100	110	9x17	716	894	868	438	398
TSAT-22/11-7'5	913	1046	35	569	358	615	400	35	1420	477	648	700	693	100	110	9x17	716	894	868	438	398
TSAT-22/11-10	913	1046	35	569	358	615	400	35	1420	477	648	700	693	100	110	9x17	716	894	868	438	398
TSAT-22/11-12'5	913	1046	35	569	358	615	400	35	1420	477	648	700	693	100	110	9x17	716	894	868	438	398
TSAT-22/11-15	913	1046	35	569	358	615	400	35	1480	477	648	700	693	100	110	9x17	716	894	868	438	398
TSAT-22/11-20	913	1046	35	569	358	615	400	35	1480	477	648	700	693	100	110	9x17	716	894	868	438	398
TSAT-22/11-25	913	1046	35	569	358	615	400	35	1565	477	648	700	693	100	110	9x17	716	894	868	438	398
TSAT-25/13-4	998	1161	35	642	412	695	423	35	1470	519	701	750	793	100	110	9x17	801	1009	953	492	452
TSAT-25/13-5'5	998	1161	35	642	412	695	423	35	1495	519	701	750	793	100	110	9x17	801	1009	953	492	452
TSAT-25/13-7'5	998	1161	35	642	412	695	423	35	1540	519	701	750	793	100	110	9x17	801	1009	953	492	452
TSAT-25/13-10	998	1161	35	642	412	695	423	35	1540	519	701	750	793	100	110	9x17	801	1009	953	492	452
TSAT-25/13-12'5	998	1161	35	642	412	695	423	35	1540	519	701	750	793	100	110	9x17	801	1009	953	492	452
TSAT-25/13-15	998	1161	35	642	412	695	423	35	1565	519	701	750	793	100	110	9x17	801	1009	953	492	452
TSAT-25/13-20	998	1161	35	642	412	695	423	35	1565	519	701	750	793	100	110	9x17	801	1009	953	492	452
TSAT-25/13-25	998	1161	35	642	412	695	423	35	1680	519	701	750	793	100	110	9x17	801	1009	953	492	452
TSAT-30/14-5'5	1206	1400	35	776	474	835	515	40	1735	624	764	815	933	100	110	9x17	1009	1248	1161	554	514
TSAT-30/14-7'5	1206	1400	35	776	474	835	515	40	1775	624	764	815	933	100	110	9x17	1009	1248	1161	554	514
TSAT-30/14-10	1206	1400	35	776	474	835	515	40	1775	624	764	815	933	100	110	9x17	1009	1248	1161	554	514
TSAT-30/14-12'5	1206	1400	35	776	474	835	515	40	1775	624	764	815	933	100	110	9x17	1009	1248	1161	554	514
TSAT-30/14-15	1206	1400	35	776	474	835	515	40	1835	624	764	815	933	100	110	9x17	1009	1248	1161	554	514
TSAT-30/14-20	1206	1400	35	776	474	835	515	40	1835	624	764	815	933	100	110	9x17	1009	1248	1161	554	514
TSAT-30/14-25	1206	1400	35	776	474	835	515	40	1925	624	764	815	933	100	110	9x17	1009	1248	1161	554	514

Dimensions in mm

CJTSA

Standard supply horizontal outlet (H) RD-90

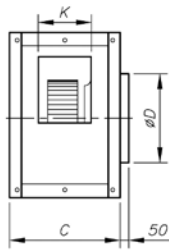
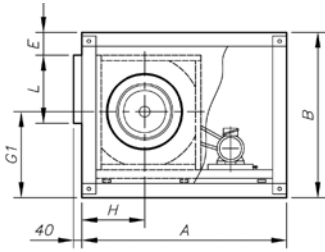

On request vertical outlet (V) LG -0

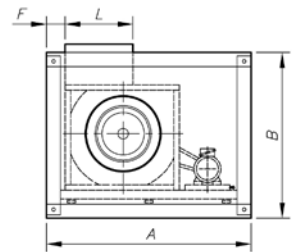
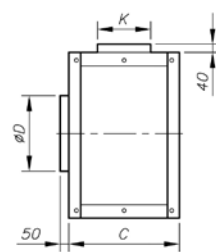

On request horizontal outlet (H) LG -90

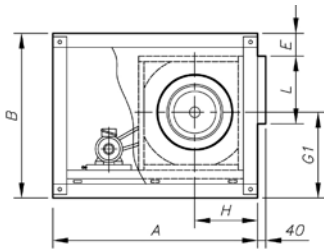
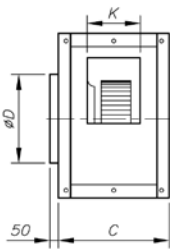

On request vertical outlet (V) RD -0

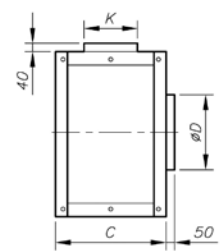
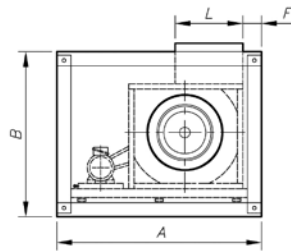

Model	A	B	C	ØD	E	with bedplate E	F	G1	with bedplate G1	H	L	with bedplate L	K
CJTSA-12/6-H	850	650	540	330	74	-	-	288	-	288	346	-	210
CJTSA-12/6-V	850	650	540	330	-	-	30	318	-	328	346	-	210
CJTSA-15/7-H	1000	755	600	400	74	-	-	328	-	328	411	-	270
CJTSA-15/7-V	1000	755	600	400	-	-	30	378	-	383	411	-	270
CJTSA-18/9-H	1200	875	620	480	74	-	-	383	-	388	491	-	305
CJTSA-18/9-V	1200	875	620	480	-	-	30	433	-	448	491	-	305
CJTSA-20/10-H	1485	1175	730	565	175	120	-	475	530	440	613	605	343
CJTSA-20/10-V	1485	1175	730	565	-	-	75	535	-	585	613	-	343
CJTSA-22/11-H	1570	1250	760	615	165	110	-	510	565	470	708	700	373
CJTSA-22/11-V	1570	1250	760	615	-	-	75	570	-	640	708	-	373
CJTSA-25/13-H	1610	1375	820	685	175	120	-	550	605	495	803	795	423
CJTSA-25/13-V	1610	1375	820	685	-	-	75	625	-	705	803	-	423
CJTSA-30/14-H	1845	1600	855	820	160	95	-	655	710	580	943	935	488
CJTSA-30/14-V	1845	1600	855	820	-	-	75	760	-	825	943	-	488

Characteristic curves

Q = Airflow in m³/h, m³/s and cfm.

Pe = Static pressure in mm.w.c., Pa and in wg.

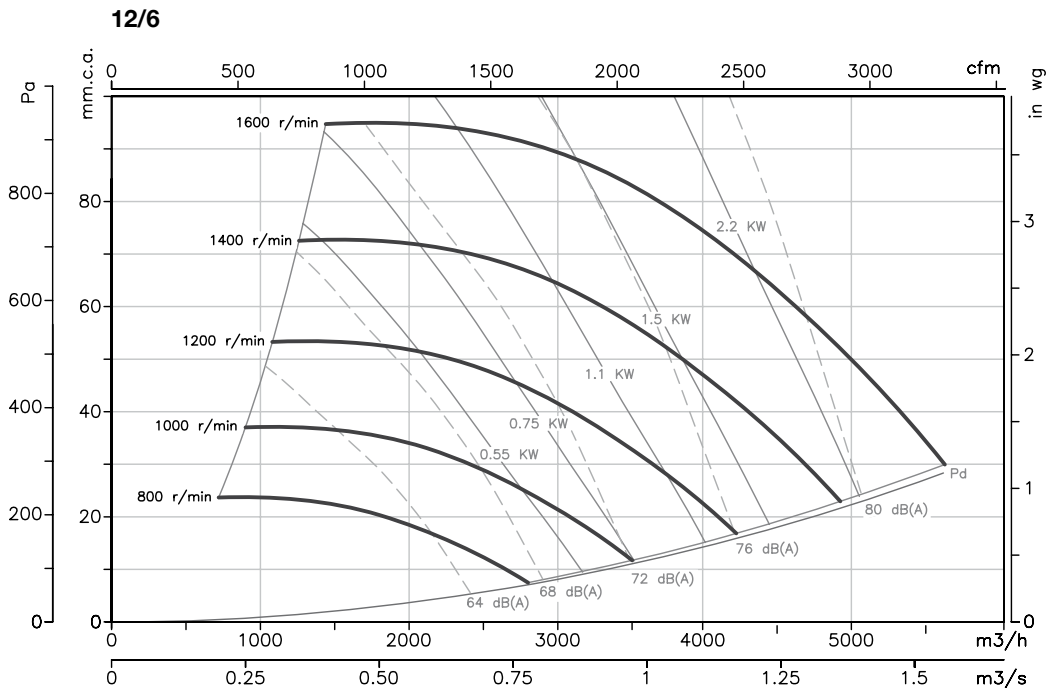

Characteristic curves

Q = Airflow in m³/h, m³/s and cfm.

Pe= Static pressure in mm.w.c., Pa and in wg.

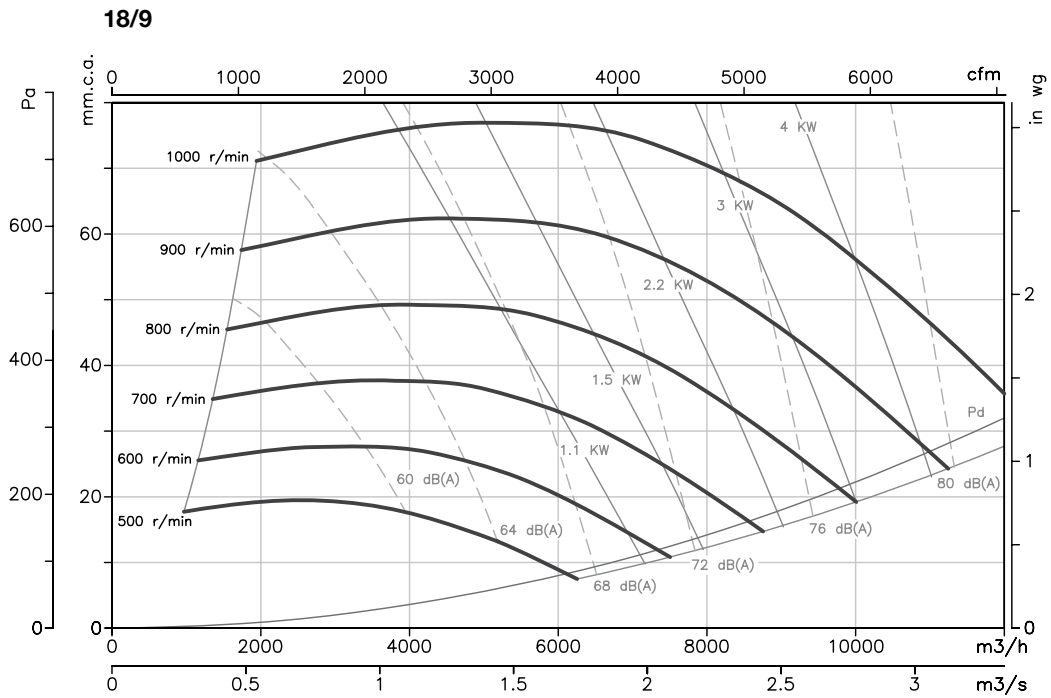
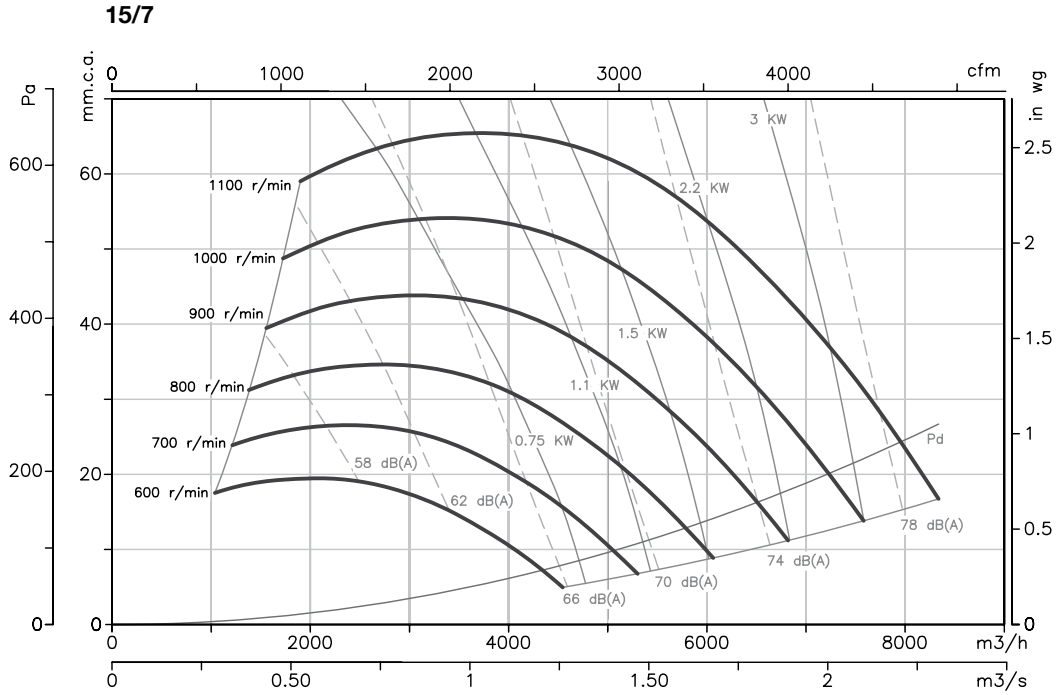

Characteristic curves

Q = Airflow in m³/h, m³/s and cfm.

Pe = Static pressure in mm.w.c., Pa and in wg.

20/10

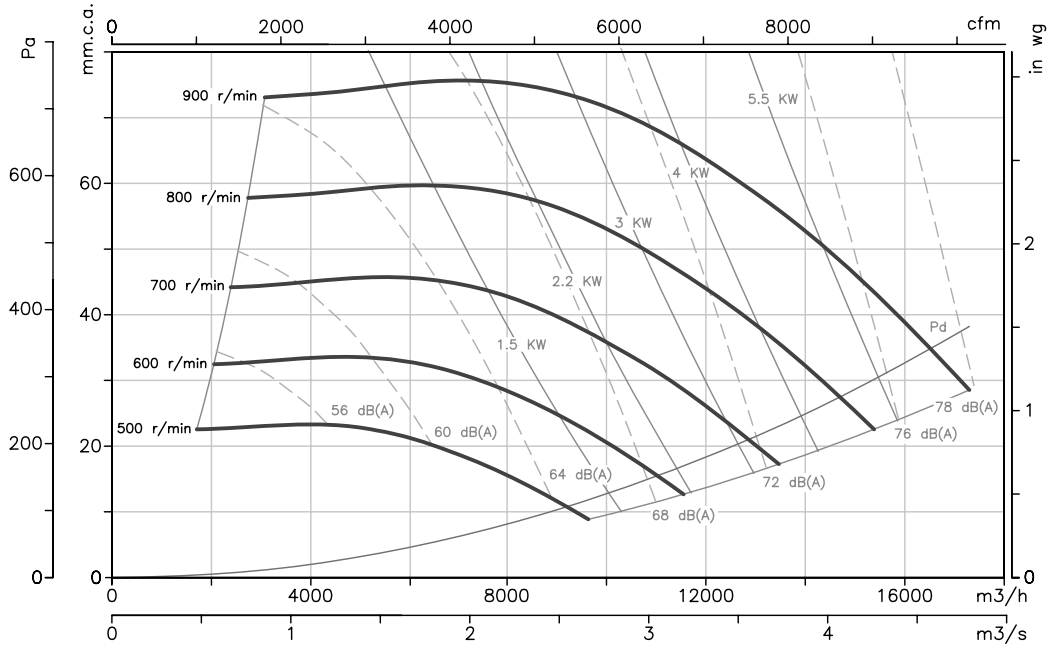

22/11

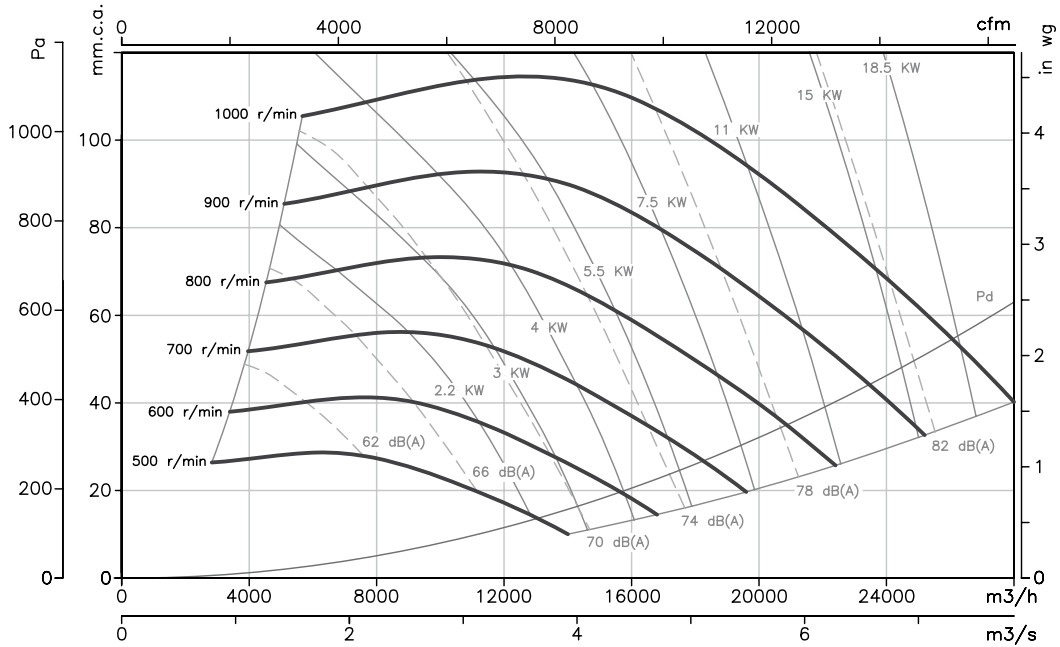

Characteristic curves

Q = Airflow in m³/h, m³/s and cfm.

Pe= Static pressure in mm.w.c., Pa and in wg.

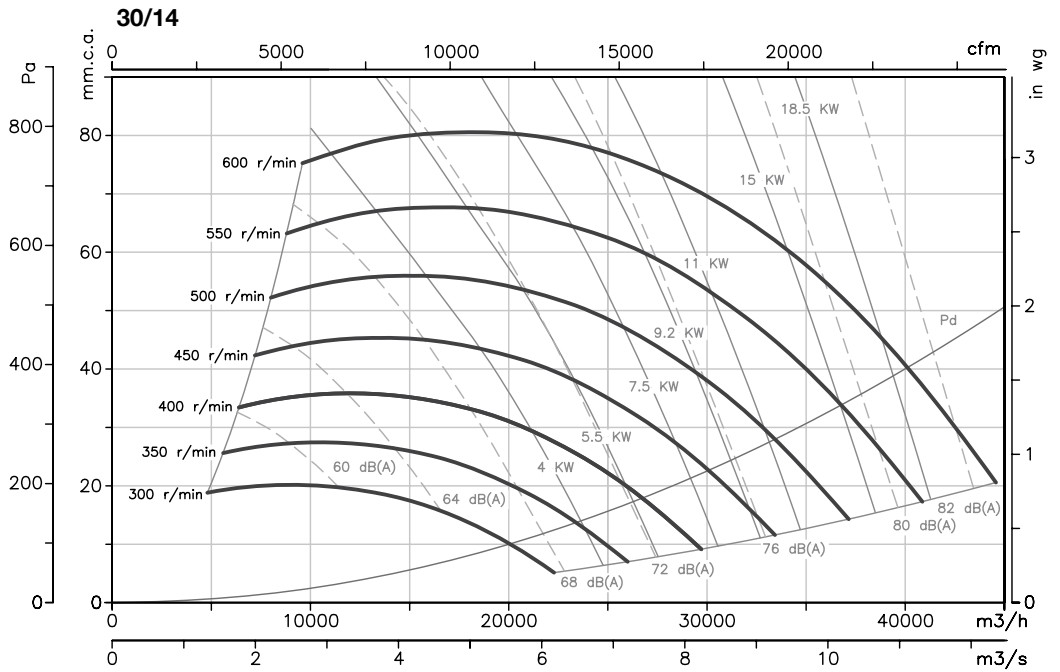
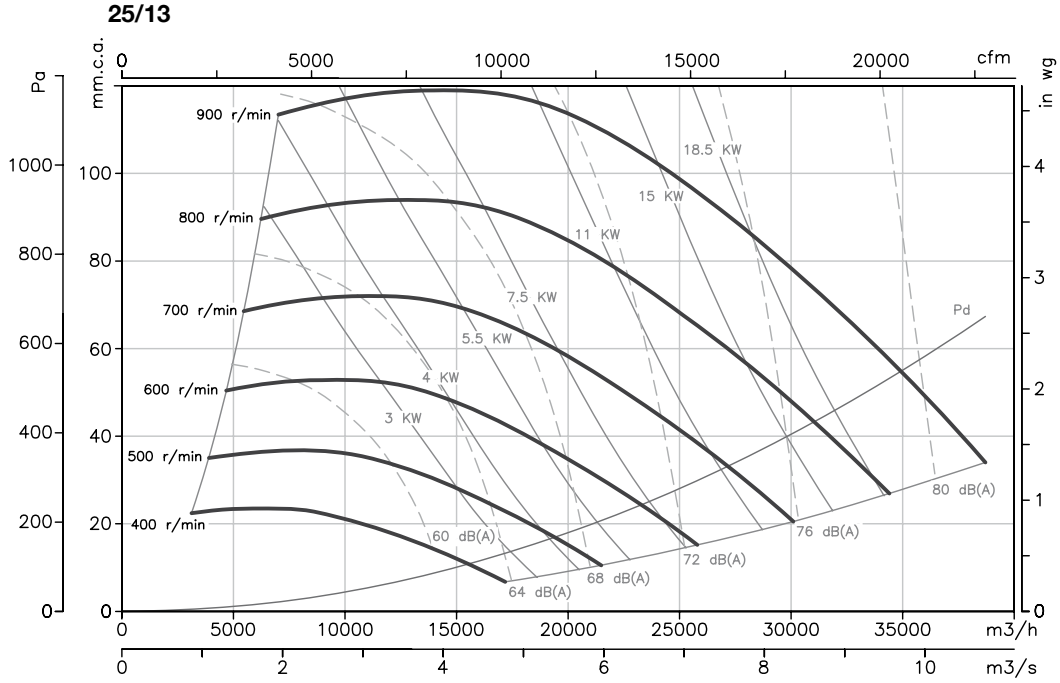

Accessories

See the accessories section.



TWIN

Soundproof ventilation units with expanded and fire-resistant polyethylene (M1), fitted with two fans for independent and alternative working, for installations where a reserve fan is necessary



Incorporates two independent fans

Fan:

- Galvanised sheet steel structure with thermal insulation and soundproofing.
- Impeller with forward-facing blades made from galvanised sheet steel
- External terminal board to aid connection

Motor:

- Class F closed motors with incorporated thermal protector, ball bearings and IP54 protection
- Single-phase 220-240V. 50Hz, and Three-phase 220-240V./380-415V. 50Hz
- Max. temperature to transport -20°C. +60°C

Finish:

- Anticorrosive galvanized sheet steel.

On request:

- With circular inlet
- With ACO accessory mounted in the box

Order code

TWIN — 10/10 — 4M — 1/4

TWIN: Ventilation units, fitted with two fans for independent and alternative working

Impeller size inches

Number of motor poles
4=1400 r/min. 50 Hz
6=900 r/min. 50 Hz

T=Three-phase
M=Single-phase

Power motor (c.v.)

Technical characteristics

Model	Speed (r/min)	Maximum admissible current (A)		Installed Power (kW)	Maximum Airflow (m³/h)	Irradiated sound level (1) dB(A)	Approx. weight (Kg)
		230V	400V				
TWIN-7/7-4M 1/5	1200	1.50		0.15	1200	43	42.0
TWIN-7/7-6M 1/10	820	0.98		0.07	950	37	42.0
TWIN-9/9-4M 1/2	1380	3.80		0.37	2250	49	70.0
TWIN-9/9-4M 3/4	1250	4.00		0.55	2400	50	71.0
TWIN-9/9-6M 1/5	825	1.90		0.15	1500	41	66.0
TWIN-9/9-6M 1/3	835	2.40		0.25	1700	42	69.0
TWIN-10/10-4M 1/2	1380	3.80		0.37	1950	49	85.0
TWIN-10/10-4M 3/4	1250	4.00		0.55	3000	50	86.0
TWIN-10/10-6M 1/3	835	2.40		0.25	2300	41	84.0
TWIN-12/12-6T 1 1/2	900	6.60	3.80	1.10	5000	55	122.0
TWIN-12/12-6M 3/4	870	4.00		0.55	3700	48	119.0
TWIN-12/12-6M 1	900	6.50		0.75	4400	49	121.0
TWIN-15/15-6T3	850		5.50	2.20	8200	54	180.0

(1) The radiated sound pressure levels dB(A) are free field measurements at 2 metres.

Dimensions in mm

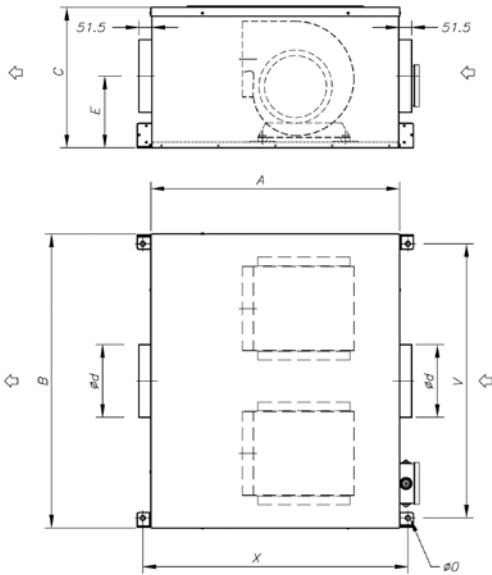

Model	A	B	C	ød	E	øO	X	V
TWIN-7/7	683	808	386	250	197	13	728.5	753.5
TWIN-9/9	833	1036	476	300	242	13	878.5	983
TWIN-10/10	945	1132	524	355	257	13	990.5	1079
TWIN-12/12	1103	1339	610	450	290	13	1148.5	1286
TWIN-15/15	1279	1639	698	500	344	13	1324.5	1586

Characteristic Curves

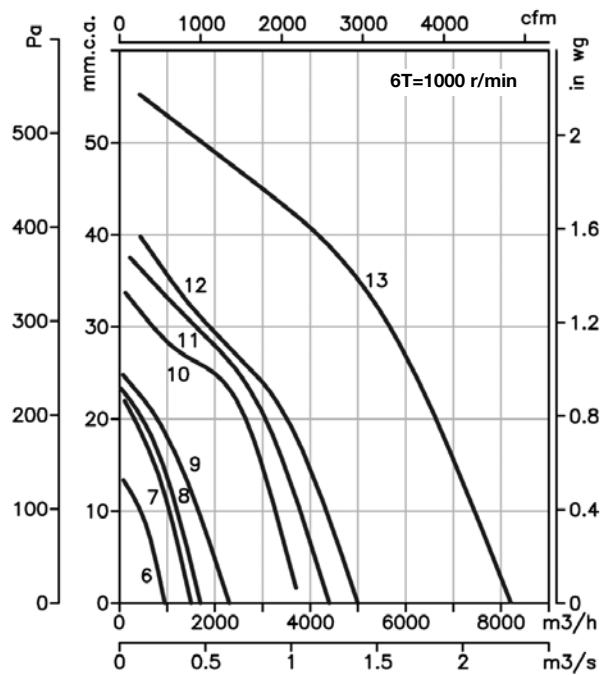
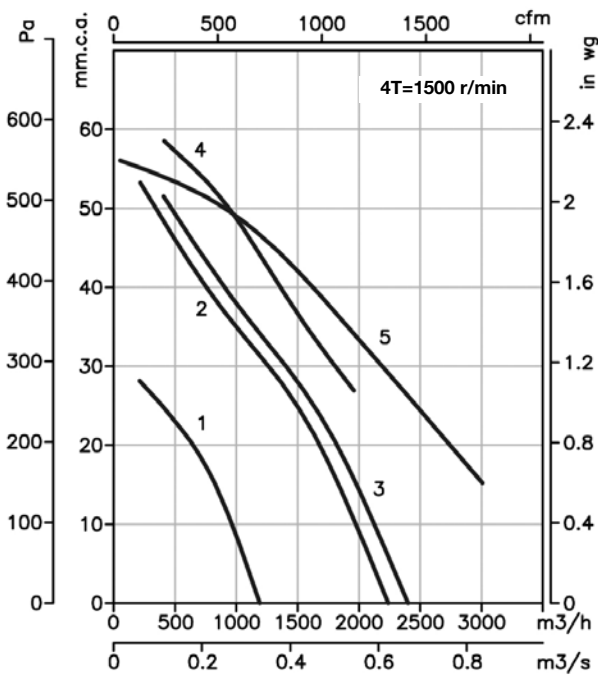

- | | |
|----------------------|------------------------|
| 1.TWIN-7/7-4M-0.2 | 8.TWIN-9/9-6M-0.33 |
| 2.TWIN-9/9-4M-0.5 | 9. TWIN-10/10-6M -0.33 |
| 3.TWIN-9/9-4M-0.75 | 10.TWIN-12/12-6M-0.75 |
| 4.TWIN-10/10-4M-0.5 | 11.TWIN-12/12-6M-1 |
| 5.TWIN-10/10-4M-0.75 | 12.TWIN-12/12-6T-1.5 |
| 6.TWIN-7/7-6M-0.1 | 13.TWIN-15/15-6T-3 |
| 7.TWIN-9/9-6M-0.2 | |

Accessories

See the accessories section.



ACO

KIT SOBREPRESIÓN

The system of pressurisation of staircases, escape routes or of confinement makes it possible to control the airflow automatically and to maintain a differential pressure of 50 Pa in a single stage, according to standard UNE EN 12101-6-2006.

STAIRWELL KIT SOBREPRESIÓN
For three-phase equipment



STAIRWELL KIT SOBREPRESIÓN
For single-phase equipment



KIT SOBREPRESIÓN WITH
RESERVE FAN



STAIRWELL KIT SOBREPRESIÓN

- Stairwell overpressure kit made up of control panel (BOXPRES KIT) and outlet units (CJHCH or CJBD) , for the pressurisation of the stairwells and escape routes. It also available for single-phase equipment NEOLINEO AND CJBC.

KIT SOBREPRESIÓN WITH RESERVE FAN

- Overpressure kit with reserve fan, made up of control panel (BOXPRES KIT II), which incorporates a system of automatic switching to keep the overpressure in the case of a stop by the main fan and TWIN or CJHCH/DUPLEX air outlet units with reserve fan.

BOXPRES



- Easy to install
- Compact and self-sufficient solution
- Preventive maintenance
- Easy starting
- Safe and functional installation



- The proper operation of the pressurisation systems depends not only on correct design but also on the proper regulation carried out by the system with the result that it is of vital importance to have calibrated and highly-precise regulation elements which make it possible to have the two situations in the case of fire, in a rapid and stable manner.
- The BOXPRES control panel, apart from satisfying the most demanding requirements, simplifies the work of the installer to the greatest possible extent.

Includes:

- Frequency varier programmed to 50 Pa
- Differential pressure probe
- Magneto thermal
- Line LED and fault
- Check button

BOXPRES is a piece of equipment with all its interconnections made and tested

- Ready to work and carry out its duties on the pressure control of the installation.
- Possibility of checking the installation so as to prevent faults
- Only the power cable, the impulsion fan and the fire signal should be connected.

The panels for single-phase equipment include:

- Frequency voltage programmed to 50 Pa
- Differential pressure probe external to the equipment.

Order code

KIT SOBREPRESIÓN — 7.100



Kit sobrepresión: Overpressure set for staircases
Kit sobrepresión II: Overpressure set with reserve fan



Maximum
Airflow

Technical characteristics

Model	Power supply	Output	Outlet unit	Airflow (m ³ /h)	Irradiated sound level * dB(A)
KIT SOBREPRESION-1060-LED	230 Vac II	230 Vac II	NEOLINEO-200	1060	38
KIT SOBREPRESION-2300-LED	230 Vac II	230 Vac II	NEOLINEO-315	2300	47
KIT SOBREPRESION-2880-LED	230 Vac II	230 Vac II	CJBC-2828-6M 1/3	2880	61
KIT SOBREPRESION-7100-LED	230 Vac II	230 Vac III	CJHCH-45-4T-0,5	7100	55
KIT SOBREPRESION-7800-LED	230 Vac II	230 Vac III	CJBD-3333-6T-1,5	7800	55
KIT SOBREPRESION-12900-LED	230 Vac II	230 Vac III	CJHCH-56-4T-1	12900	60
KIT SOBREPRESION-17000-LED	230 Vac II	230 Vac III	CJHCH-63-4T-1,5	17000	61
KIT SOBREPRESION-7100-BOX	400 Vac III	400 Vac III	CJHCH-45-4T-0,5	7100	55
KIT SOBREPRESION-7800-BOX	400 Vac III	400 Vac III	CJBD-3333-6T-1,5	7800	55
KIT SOBREPRESION-12900-BOX	400 Vac III	400 Vac III	CJHCH-56-4T-1	12900	60
KIT SOBREPRESION-17000-BOX	400 Vac III	400 Vac III	CJHCH-63-4T-1,5	17000	61
KIT SOBREPRESION II-6240-BOX	400 Vac III	400 Vac III	TWIN-12/12-6T-1,5	6240	55
KIT SOBREPRESION II-9520-BOX	400 Vac III	400 Vac III	TWIN-15/15-6T-3	9520	54
KIT SOBREPRESION II-12900-BOX	400 Vac III	400 Vac III	CJHCH/DUPLEX-56-4T-1-H	12900	60
KIT SOBREPRESION II-17000-BOX	400 Vac III	400 Vac III	CJHCH/DUPLEX-63-4T-1,5-H	17000	61
SONDA TPDA SI-PRESIÓN c/DISPLAY					
SONDA TPDA 984M.523 P04					
SONDA TPDA 984M.523 P14 LED					
BOXPRES KIT-3A 230Vac	230 Vac II	230 Vac II			
BOXPRES KIT-10A 230Vac	230 Vac II	230 Vac II			
BOXPRES KIT-0,75KW 230Vac	230 Vac II	230 Vac III			
BOXPRES KIT-1,5KW 230Vac	230 Vac II	230 Vac III			
BOXPRES KIT-0,75KW 400Vac	400 Vac III	400 Vac III			
BOXPRES KIT-1,5KW 400Vac	400 Vac III	400 Vac III			
BOXPRES KIT-2,2KW 400Vac	400 Vac III	400 Vac III			
BOXPRES KIT II - 1,5KW 400Vac	400 Vac III	400 Vac III			
BOXPRES KIT II - 2,2KW 400Vac	400 Vac III	400 Vac III			

Dimensions in mm

CJHCH

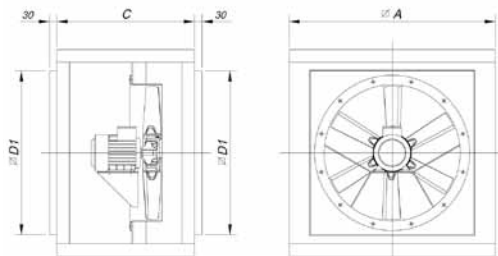

Model	∅A	C	∅D1
CJHCH-40/45/50	700	550	565
CJHCH-56/63	825	550	690

CJBD

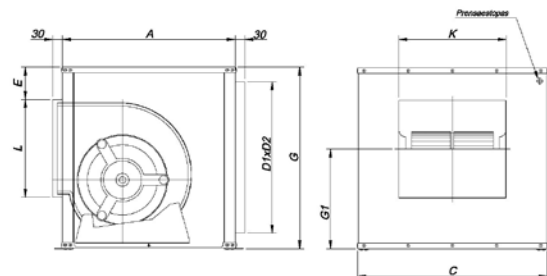

Model	Equiv. inches	A	B	C	E	D1xD2	G1	L	K
CJBD-3333	12/12	650	650	700	92	556X606	379	358	400

Dimensions in mm

TWIN

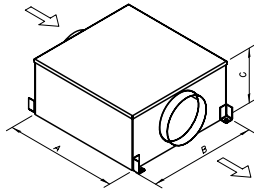

Model	A	B	C
TWIN-12/12	1103	1139	610
TWIN 15/15	1279	1639	698

CJHCH/DUPLEX

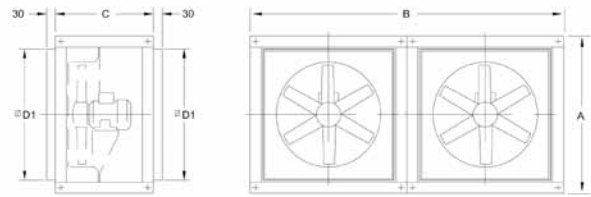

Model	∅A	B	C	∅D1
CJHCH/DUPLEX-56/63	825	1650	550	690

NEOLINEO

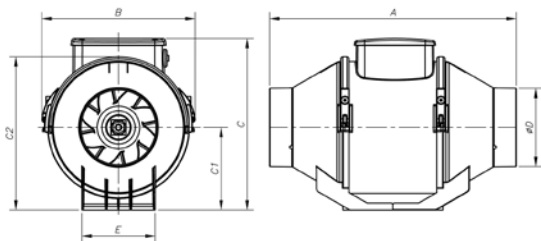

Model	A	B	C	C1	C2	∅D	E
NEOLINEO-200	300	234,5	260,5	125,5	235	196	140
NEOLINEO-315	448	361,5	392,5	188,5	359	312	220,5

CJBC

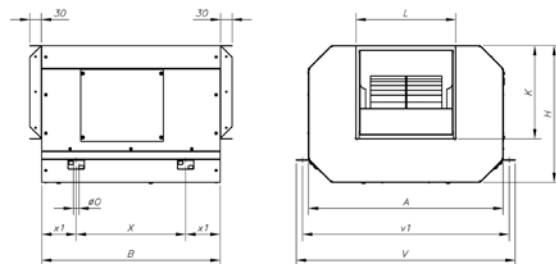

Model	A	B	H	K	L	∅O	V	v1	X	x1
CJBC-2828-6M-1/3	696	645	460	290	320	15	755	725	445	100

BOXPRESS KIT SOBREPRESIÓN

Technical characteristics and measurements

Model	Power kW	Power supply (V/Hz)	Output (V/Hz)	Output current (A)	Size	Measurements (L x W x D) mm
BOXPRES KIT-3A 230Vac	-	230 Vac II	230 Vac II	3	-	255 x 170 x 140 mm
BOXPRES KIT-10A 230Vac	-	230 Vac II	230 Vac II	10	-	255 x 170 x 140 mm
BOXPRES KIT-0,75kW 230Vac	0,75	230 V II / 50Hz	230 V III / 50Hz	4,3	1	270 x 270 x 170 mm
BOXPRES KIT-1,5kW 230Vac	1,5	230 V II / 50Hz	230 V III / 50Hz	7	1	270 x 270 x 170 mm
BOXPRES KIT-0,75KW 400Vac	0,75	400 V III / 50Hz	400 V III / 50Hz	2,2	1	270 x 270 x 170 mm
BOXPRES KIT-1,5KW 400Vac	1,5	400 V III / 50Hz	400 V III / 50Hz	4,1	1	270 x 270 x 170 mm
BOXPRES KIT-2,2KW 400Vac	2,2	400 V III / 50Hz	400 V III / 50Hz	5,8	2	360 x 360 x 205 mm

BOXPRES KIT-3A / KIT-10A

Connection of power and motor

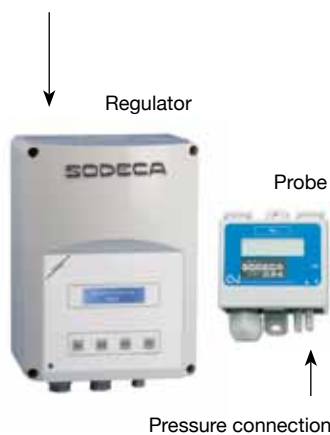

Stuffing-box for cable input to equipment Size 1

M 20 x 1.5mm
Connection of power and motor

M 12 x 1.5mm
Fire signal connection

Pressure connection



Stuffing-box for cable input to equipment Size 2

M 20 x 1.5mm
Connection of power and motor

M 12 x 1.5mm
Fire signal connection

Pressure connection



BOXPRES KIT SOBREPRESIÓN II

For equipment with reserve fan.

Technical characteristics and measurements

Model	Power kW	Power supply (V/Hz)	Output (V/Hz)	Output current (A)	Size	Measurements (L x W x D)
BOXPRES KIT II - 1,5KW 400Vac	1,5	400 V III / 50Hz	400 V III / 50Hz	4,1	1	270 x 270 x 170 mm
BOXPRES KIT II - 2,2KW 400Vac	2,2	400 V III / 50Hz	400 V III / 50Hz	5,4	2	360 x 360 x 205 mm

* The two motors never operate simultaneously

**Stuffing-box for cable input to equipment
Size 1**



**Stuffing-box for cable input to equipment
Size 2**



Example of use

Overpressure smoke control method; this system consists of pressurization by means of the injection of air in spaces which are used as escape routes for people in case of fire, such as stair wells, passageways, corridors, elevators, etc. Above all in densely occupied tall buildings. This method is based on smoke control by means of the speed of air and the artificial barrier which is created by excess air pressure over smoke, so that it cannot enter escape routes.

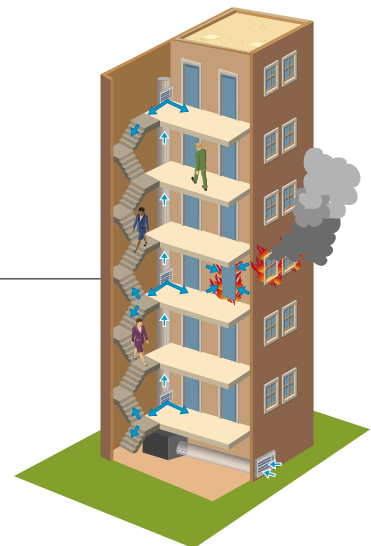

BR

High-performance centrifugal fans of the PLUG FAN type, for use without casing



Fan:

- Steel sheet structure
- Impeller with backward-curved blades made from robust sheet steel



Motor:

- Motors with IE-2 efficiency, except for motors with lower powers than 0.75 kW, monophasic motors or two-speed motors
- Class F motors with ball bearings, IP55 protection
- Three-phase 230/400V.-50Hz. (up to 5.5CV.) and 400/690V.-50Hz. (power over 5.5CV.)
- Max. temperature of air for transport: -20°C.+ 120°C.

Finish:

- Anticorrosive finish in polyester resin, polymerised at 190°C, after alkaline degreasing and phosphate-free pre-treatment.

On request:

- Special windings for different voltages.

Order code

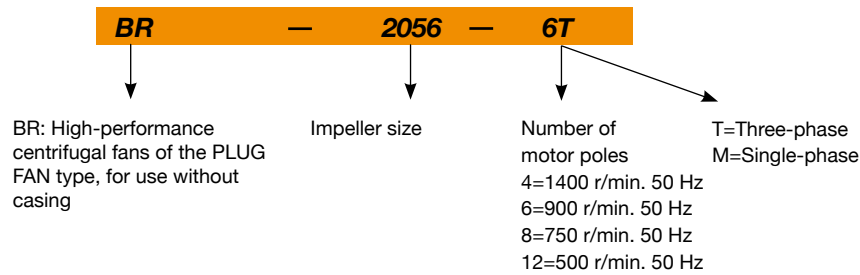

Technical characteristics

Model	Speed (r/min)	Maximum admissible current (A)			Installed Power (kW)	Maximum Airflow (m ³ /h)	Approx. weight (Kg)
		230V	400V	690V			
BR-1240-6T	930	2.8	1.6	-	0.55	3100	39
BR-1850-4T	1425	5.2	3.0	-	1.50	7300	37
BR-1850-6T	930	2.8	1.6	-	0.55	4500	36
BR-2056-4T	1435	7.8	4.5	-	2.20	9500	49
BR-2056-6T	940	3.4	2.0	-	0.75	6500	44
BR-2263-4T	1460	-	10.3	5.9	5.50	16600	118
BR-2263-6T	945	4.9	2.8	-	1.10	10050	53
BR-2071-4T	1460	-	18.9	10.9	11.00	23800	204
BR-2071-6T-3	950	9.3	5.4	-	2.20	14050	79
BR-2071-6T-5.5	970	15.1	8.7	-	4.00	16800	170
BR-2880-6T	970	15.1	8.7	-	4.00	17080	168

Dimensions in mm

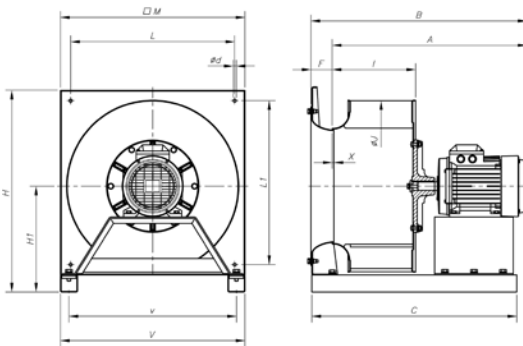

Model	A	B	C	ød	F	H	H1	I	øJ	L	L1	M	V	v	X
BR-1240-6T	458.5	565	568	9	106.5	555.5	310	197	400	440	450	500	500	450	4
BR-1850-4T	581.5	643.5	600	9	62	590	310	243.5	500	480	480	540	540	490	5
BR-1850-6T	533.5	595.5	600	9	62	590	310	243.5	500	480	480	540	540	490	5
BR-2056-4T	590	665	660	9	75	700	372	264	560	540	590	600	600	550	5.5
BR-2056-6T	575	650	660	9	75	700	372	264	560	540	590	600	600	550	5.5
BR-2263-4T	720	885	800	9	165	809.5	429.5	297	635	700	700	760	760	710	6
BR-2263-6T	655	732	740	9	77	735	387	300	630	610	625	670	670	620	6.5
BR-2071-4T	832	1022	902	9	190	890	470	295	710	780	780	840	840	790	6
BR-2071-6T-3	735	825	800	9	90	815	424.5	333.5	710	690	705	750	750	700	7
BR-2071-6T-5.5	757	947	935	9	190	890	470	329	710	780	780	840	840	790	6
BR-2880-6T	825	930	900	9	105	890	440	373	800	780	780	840	840	790	8

Characteristic curves

Q = Airflow in m³/h, m³/s and cfm.

Pe = Static pressure in mm.w.c., Pa and in wg.

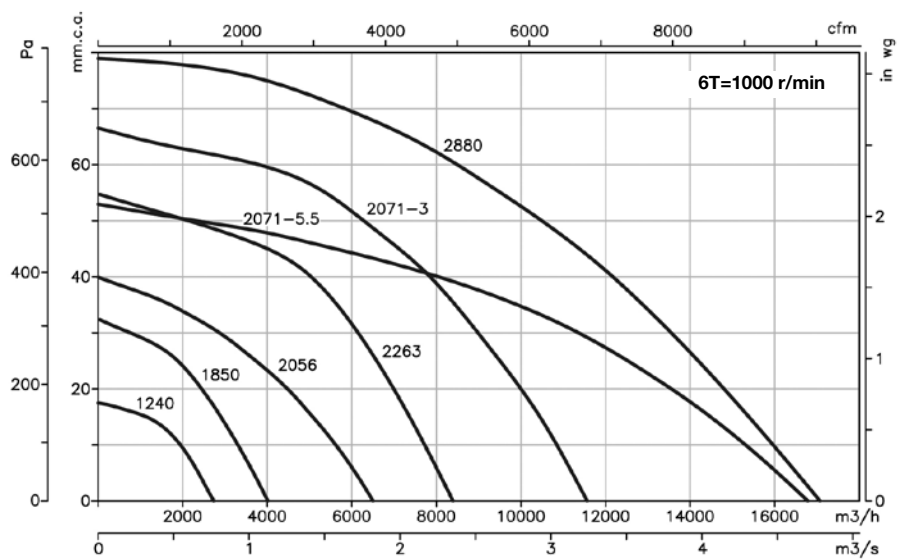
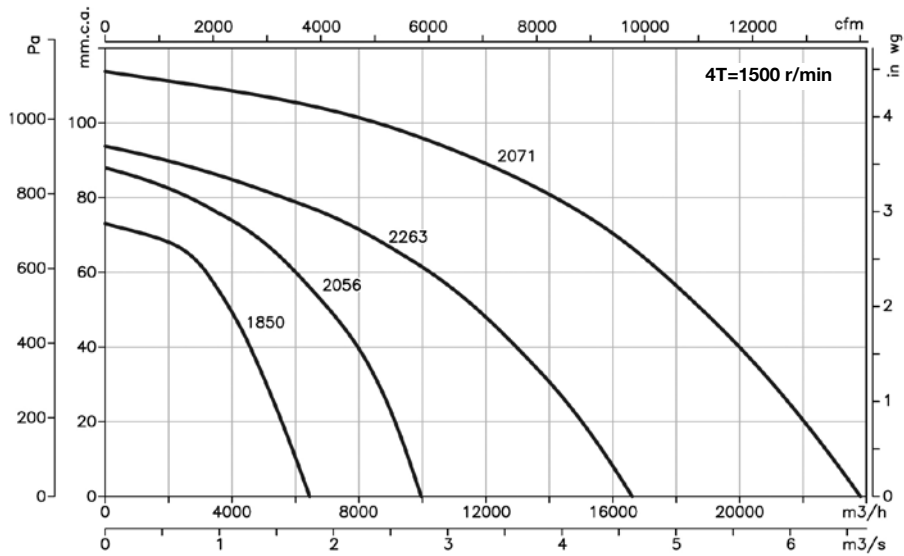

Accessories

See the accessories section.



CJBR

Ventilation units with sandwich-panel soundproofing and linear airflow between the inlet and outlet.



Highly-efficient soundproofing

Fan:

- Galvanised sheet steel structure with thermal insulation and soundproofing.
- Impeller with backward-curved blades made from galvanised sheet steel
- Outlet mounting on any side of the box possible, during installation

Motor:

- Single-phase motors with IE-2 efficiency, except lower powers 0.75 kW
- Class F motors with ball bearings, IP55 protection.
- Three-phase 230/400V.-50Hz. (up to 5.5CV.) and 400/690V.-50Hz. (power over 5.5CV.)
- Max. temperature of air for transport: -20°C.+ 60°C.

Finish:

- Anticorrosive galvanized sheet steel.

On request:

- With circular outlet via the TAC accessory
- With two speed motors

Order code

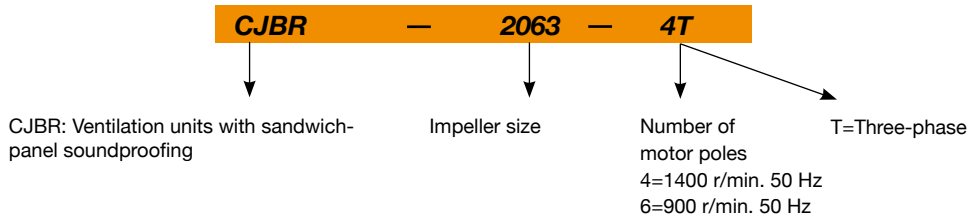

Technical characteristics

Model	Speed (r/min)	Maximum admissible current (A) 400V	Installed Power (kW)	Maximum Airflow (m³/h)	Sound pressure level dB(A)	Approx. weight (Kg)
CJBR-1240-4T	1430	2.00	0.75	4400	62	79
CJBR-1850-4T	1420	3.50	1.50	6700	70	82
CJBR-2056-4T	1430	4.90	2.20	9500	72	129
CJBR-2056-6T	935	2.20	0.75	6500	62	123
CJBR-2263-4T	1460	12.50	5.50	16700	74	179
CJBR-2263-6T	950	3.00	1.10	9000	64	135
CJBR-2071-4T	1460	21.00	10.50	25050	83	220
CJBR-2071-6T-3	940	5.60	2.20	12500	68	149
CJBR-2071-6T-5.5	970	11.00	4.00	16800	70	196
CJBR-2880-6T	970	11.00	4.00	17080	71	194

Acoustic features

The specified values are determined according to free field measurements of sound levels in dB(A) at an equivalent distance of twice the fan's span plus the impeller's diameter, with a minimum of 1.5 m.

Sound power Lw(A) spectrum in dB(A) via frequency band in Hz.

Model	63	125	250	500	1000	2000	4000	8000	Model	63	125	250	500	1000	2000	4000	8000
CJBR-1240-4	47	61	67	70	70	71	61	50	CJBR-2263-6	61	67	72	73	77	76	69	62
CJBR-1850-4	66	72	77	78	81	80	73	68	CJBR-2071-4	80	81	89	92	95	96	92	78
CJBR-2056-4	67	73	79	79	83	83	75	68	CJBR-2071-6-3	65	71	76	77	81	80	73	66
CJBR-2056-6	57	63	69	69	73	73	65	58	CJBR-2071-6-5.5	66	65	80	79	83	83	72	61
CJBR-2263-4	74	79	85	87	85	82	75	67	CJBR-2880-6	68	74	79	80	84	83	76	69

Dimensions in mm

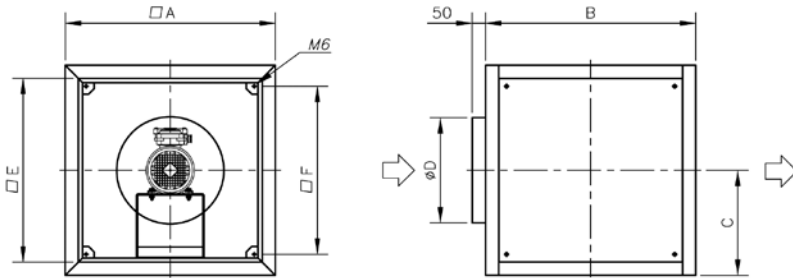

Model	A	B	C	D	E	F
CJBR-1240-6T	800	800	400	400	700	640
CJBR-1850-4T	800	800	400	400	700	640
CJBR-1850-6T	800	800	400	400	700	640
CJBR-2056-4T	925	925	462.5	450	825	765
CJBR-2056-6T	925	925	462.5	450	825	765
CJBR-2263-4T	1000	1000	500	630	900	840
CJBR-2263-6T	925	925	462.5	560	825	765
CJBR-2071-4T	1060	1060	530	710	960	900
CJBR-2071-6T-3	1000	1000	500	630	900	840
CJBR-2071-6T-5'5	1060	1060	530	710	960	900
CJBR-2880-6T	1060	1060	530	710	960	900

Characteristic curves

Q = Airflow in m³/h, m³/s and cfm.

Pe = Static pressure in mm.w.c., Pa and in wg.

Accessories

See the accessories section.

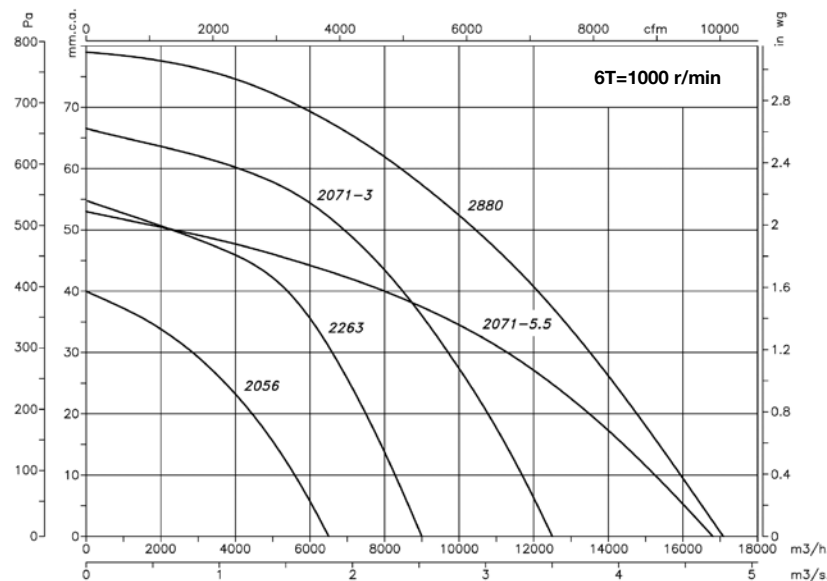
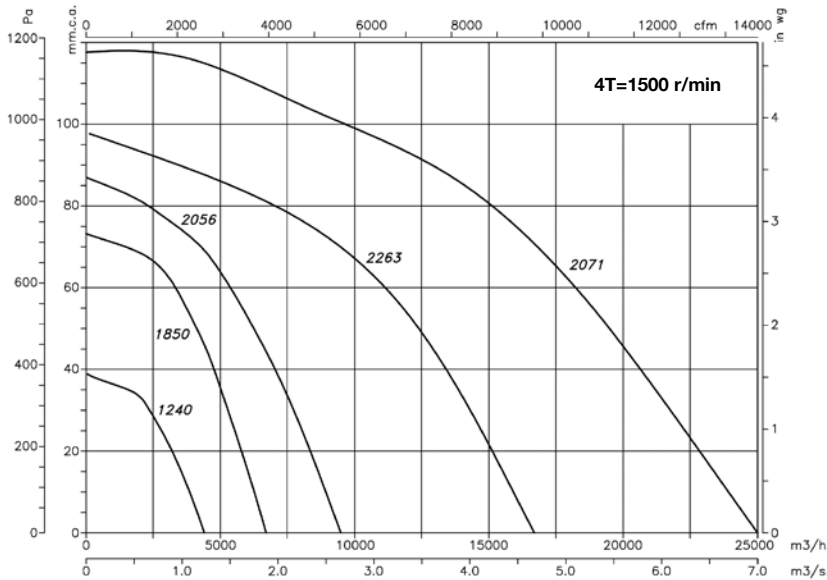

CJEC

Extraction units 400°C/2h with large hatch to facilitate maintenance.



Motor-impeller unit easy to dismantle

Extraction units with large hatch to facilitate maintenance.

Fan:

- Galvanized sheet steel structure.
- Impeller with backward-curved blades made from galvanised sheet steel
- Approval according to Standard EN-12101-3-2002 certification No.: 0370-CPD-0382
- Possibility of mounting the outlet on either side of the box during installation.

Motor:

- Class F two-speed motors with ball bearings, IP55 protection
- Three-phase 400V.-50Hz. DHALANDER
- Max. temperature of air for transport: -20°C.+ 120°C.

Finish:

- Anticorrosive galvanized sheet steel.

On request:

- With single-speed motors.



Order code

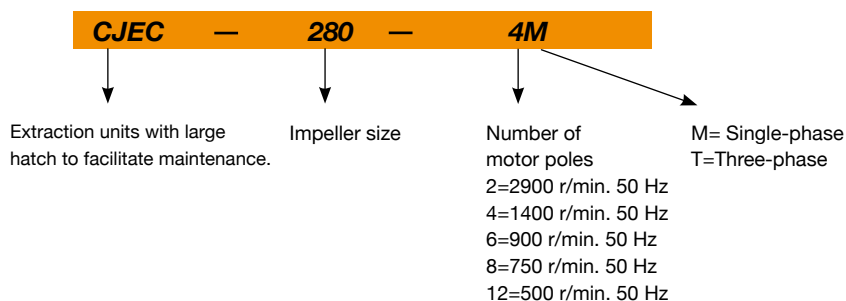

Technical characteristics

Model	Speed (r/min)	Maximum admissible current (A)		Installed Power (kW)	Maximum Airflow (m³/h)	Sound pressure level dB(A)		Approx. weight (Kg)
		230V	400V			Inlet	Outlet	
CJEC-280-4/8T	1380 / 720		0.60 / 0.70	0.18 / 0.04	1370 / 685	55 / 40	60 / 45	61
CJEC-280-4M	1380	0.65		0.10	1370	55	60	61
CJEC-315-4/8T	1430 / 640		0.80 / 0.40	0.25 / 0.06	1650 / 825	59 / 44	63 / 48	63
CJEC-315-4M	1400	0.95		0.18	1650	59	63	63
CJEC-355-4/8T	1360 / 700		1.10 / 0.50	0.37 / 0.09	3000 / 1500	61 / 46	66 / 51	75
CJEC-355-4M	1360	1.35		0.25	3000	61	66	75
CJEC-400-4/8T	1410 / 680		1.80 / 0.65	0.55 / 0.13	4000 / 2000	65 / 50	69 / 54	79
CJEC-400-4M	1380	3.30		0.55	4000	65	69	79
CJEC-450-4/8T	1400 / 675		2.15 / 0.75	0.75 / 0.17	5500 / 2750	68 / 53	72 / 57	89
CJEC-450-4M	1380	4.40		0.75	5500	68	72	89
CJEC-500-4/8T	1390 / 700		4.00 / 1.60	1.70 / 0.35	7600 / 3800	70 / 55	75 / 60	110
CJEC-560-6/12T	940 / 460		3.50 / 1.20	1.30 / 0.20	9500 / 4750	77 / 62	82 / 67	129

Acoustic features

The specified values are determined according to free field measurements of pressure and sound levels in dB(A) at an equivalent distance of twice the fan's span plus the turbine's diameter, with a minimum of 1.5 m.

Sound power Lw(A) spectrum in dB(A) via frequency band in Hz.

Values taken at inlet with maximum airflow.								Values taken at outlet with maximum airflow.									
Model	63	125	250	500	1000	2000	4000	8000	Model	63	125	250	500	1000	2000	4000	8000
280-4	42	47	62	59	60	58	53	45	280-4	42	45	65	66	65	65	58	49
280-8	27	32	47	44	45	43	38	30	280-8	27	30	50	51	50	50	43	34
315-4	53	62	64	64	64	62	54	42	315-4	45	59	67	69	68	68	60	53
315-8	38	47	49	49	49	47	39	27	315-8	30	44	52	54	53	53	45	38
355-4	52	62	68	63	64	66	62	53	355-4	48	67	68	71	72	71	64	55
355-8	37	47	53	48	49	51	47	38	355-8	33	52	53	56	57	56	49	40
400-4	60	69	72	65	68	69	65	56	400-4	52	70	73	73	75	74	70	59
400-8	45	54	57	50	53	54	50	41	400-8	37	55	58	58	60	59	55	44
450-4	56	65	71	76	72	71	65	57	450-4	56	69	75	77	79	76	71	61
450-8	56	69	75	77	79	76	71	61	450-8	41	54	60	62	64	61	56	46
500-4	57	62	73	76	76	75	69	60	500-4	58	67	78	79	83	80	74	63
500-8	42	47	58	61	61	60	54	45	500-8	43	52	63	64	68	65	59	48
560-6	69	78	80	81	82	82	79	57	560-6	65	79	85	86	90	86	81	72
560-12	54	63	65	66	67	67	64	57	560-12	50	64	70	71	75	71	66	57

Dimensions in mm

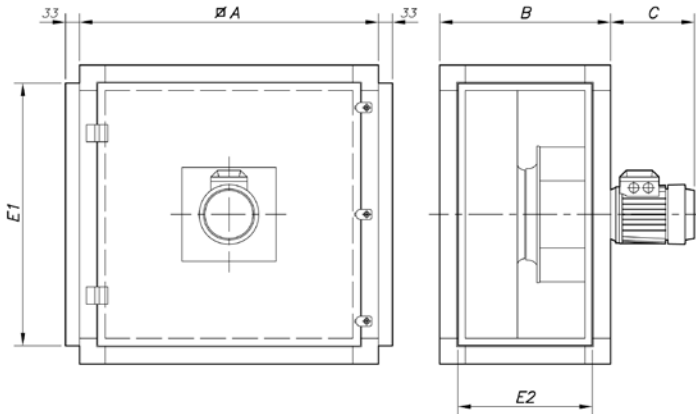

Model	ØA	B	C	E1	E2
CJEC-280	700	400	200	618	318
CJEC-315	700	400	200	618	318
CJEC-344	800	505	200	718	423
CJEC-400	800	505	225	718	423
CJEC-450	900	550	225	818	468
CJEC-500	900	550	260	818	468
CJEC-560	1000	700	290	918	618

Characteristic curves

Q = Airflow in m³/h, m³/s and cfm.

Pe = Static pressure in mm.w.c., Pa and in wg.

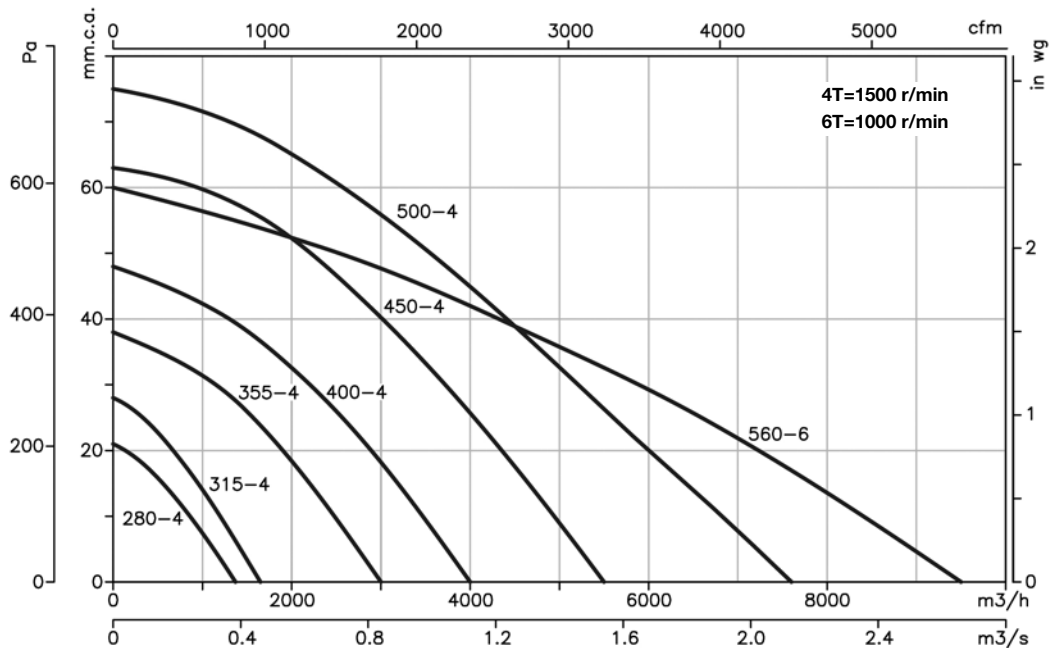

Characteristic curves

Q = Airflow in m³/h, m³/s and cfm.

Pe = Static pressure in mm.w.c., Pa and in wg.

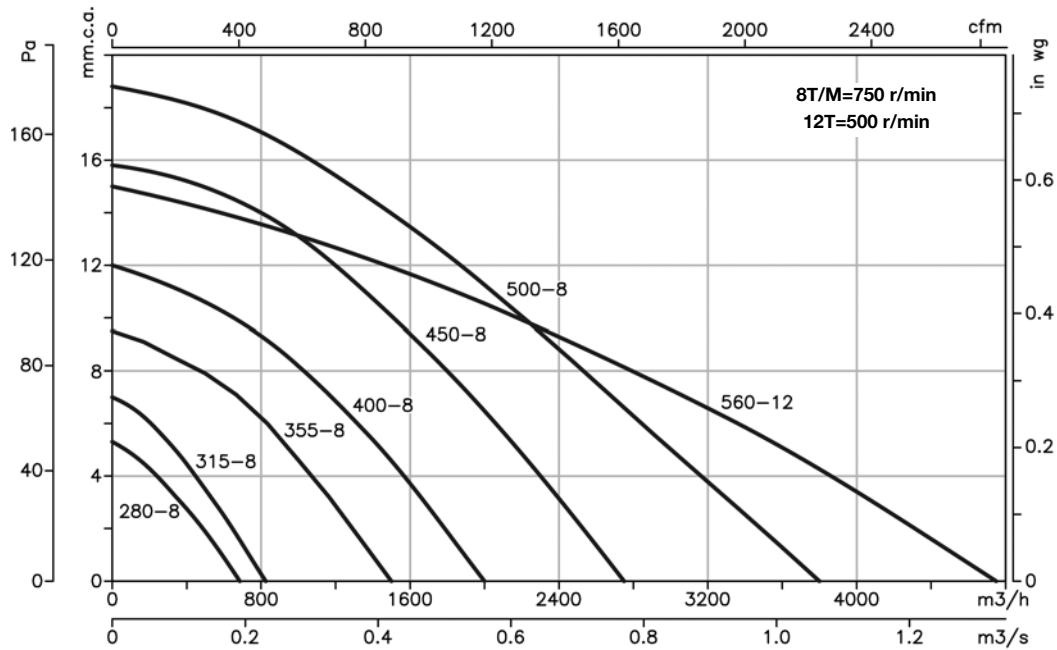

CJEC installations

Possibility of installing the CJEC series by changing the position of the inlet and outlet panels

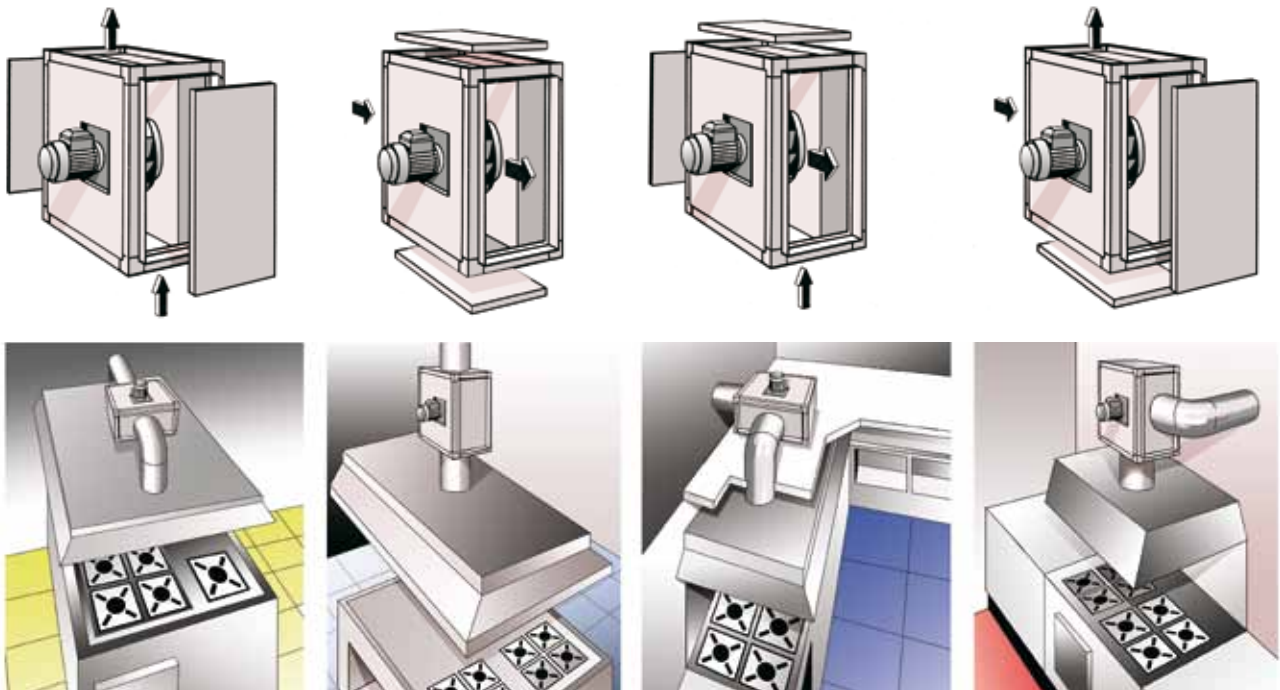

Accessories

See the accessories section



CB

Centrifugal single-inlet fans with multi-blade impeller



Model version CB-2240

Fan:

- Steel sheet casing
- Impeller with forward-facing blades made from galvanised sheet steel

Motor:

- Motors with IE-2 efficiency, except for motors with lower powers than 0.75 kW, monophase motors or two-speed motors
- Class F motors with ball bearings, IP55 protection, except single-phase models which have IP54 protection
- Single-phase 230V.-50Hz., and three-phase 230/400V.-50Hz.
- Max. temperature of air for transport: -20°C.+ 120°C.

Finish:

- Anticorrosive finish in polyester resin, polymerised at 190°C, after alkaline degreasing and phosphate-free pre-treatment.

On request:

- Special windings for different voltages

Order code

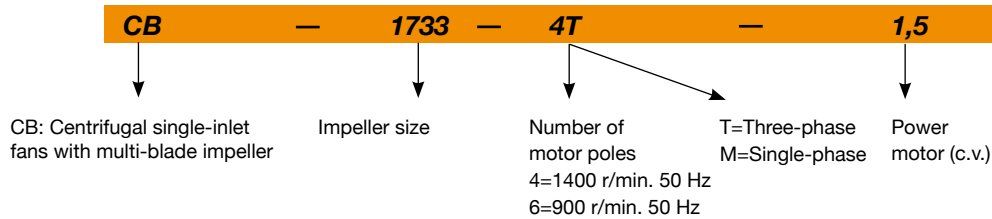

Technical characteristics

Model	Speed (r/min)	Maximum admissible current (A)		Installed Power (kW)	Maximum Airflow (m³/h)	Sound pressure level dB(A)	Approx. weight (Kg)
		230V	400V				
CB-820-4T	1410	1.58	0.91	0.25	2100	64	12.2
CB-820-4M	1410	2.00		0.25	2100	64	12.2
CB-1428-4T	1380	3.84	2.22	0.75	2800	69	17.6
CB-1428-4M	1300	4.00		0.75	2800	69	17.6
CB-1428-6T	950	1.47	0.85	0.25	2000	65	16.2
CB-1428-6M	940	1.70		0.25	2000	65	16.2
CB-1733-4T-1.5	1350	4.78	2.76	1.10	3200	74	25.0
CB-1733-4T-2	1400	6.69	3.86	1.50	4000	75	25.0
CB-1733-6T	900	3.91	2.26	0.75	3400	68	23.2
CB-1733-6M	900	5.50		0.75	3400	68	23.2
CB-2240-6T	920	9.32	5.36	2.20	7000	74	68.0

Acoustic features

Sound power Lw(A) spectrum in dB(A) via frequency band in Hz.

Model	63	125	250	500	1000	2000	4000	8000	Model	63	125	250	500	1000	2000	4000	8000
820-4T	39	49	60	67	71	68	66	59	1733-4-2	50	60	71	78	82	79	77	70
1428-4	44	54	65	72	76	73	71	64	1733-6	43	53	64	71	75	72	70	63
1428-6	40	50	61	68	72	69	67	60	2240-6	52	61	72	79	83	81	79	72
1733-4-1.5	49	59	70	77	81	78	76	69									

Dimensions in mm

CB-820...1733

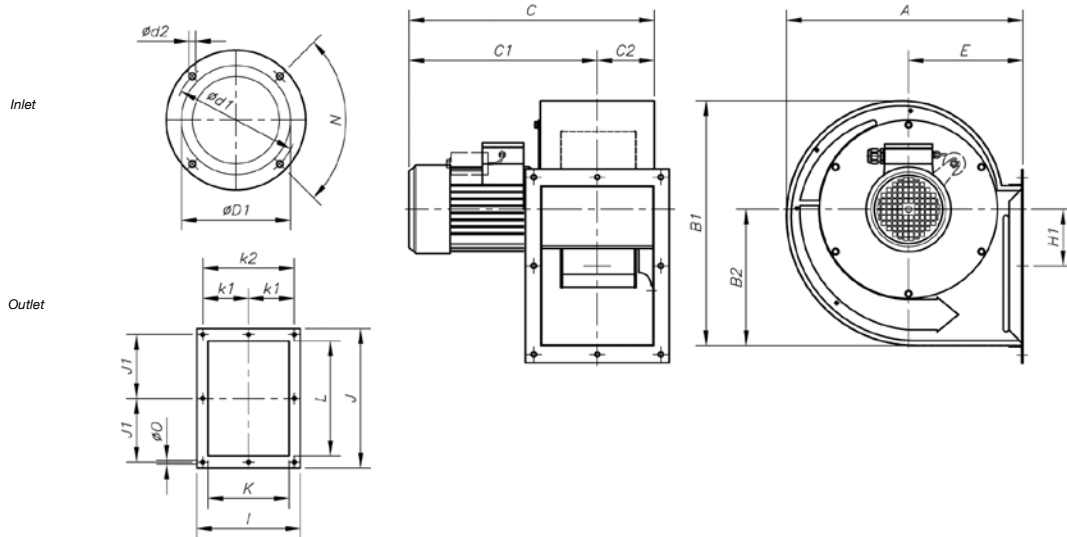

Model	A	B1	B2	C	C1	C2	$\varnothing D1^*$	$\varnothing d1$	$\varnothing d2$	E	H1	I	J	J1	K	k1	k2	L	N	$\varnothing O$
CB-820	321	374	222	339	268	71	200	230	M6	138	135.5	184	213	94.5	130	-	160	160	4x90°	9
CB-1428	428	442	246	444	341	103	250	294	M6	207	102	260	350	160	202	115	230	286	6x60°	9
CB-1733	497	522	291	520	397	123	315	355	M6	236	120.5	315	415	186	240	140	280	339	6x60°	9

* Recommended nominal diameter for duct.

CB-2240

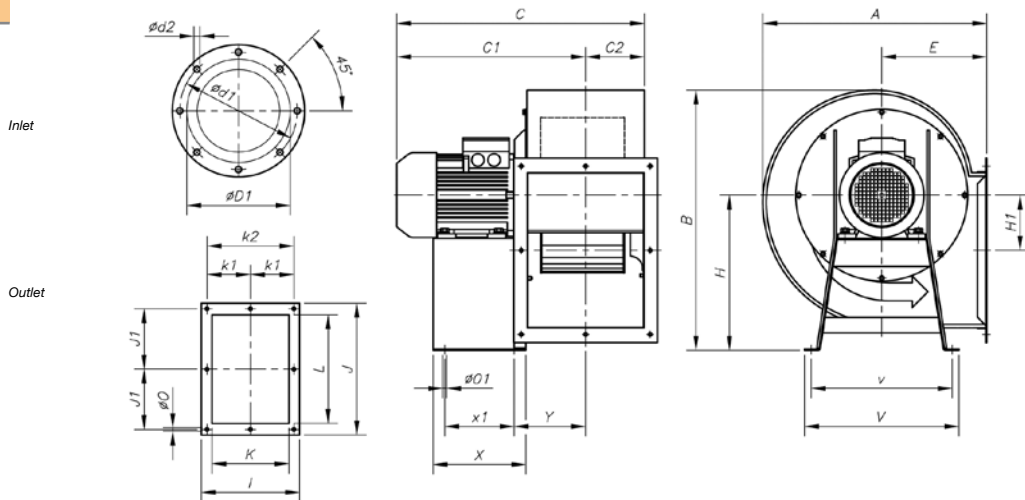

Model	A	B	C	C1	C2	$\varnothing D1^*$	$\varnothing d$	$\varnothing d1$	$\varnothing d2$	E	H	H1	I	J	J1	K	k1	k2	L	$\varnothing O$	$\varnothing O1$	V	v	X	x1	Y
CB-2240	580	674	642	490	152	355	-	410	M6	272	402	143	372	478	218	300	167	334	400	9	13	400	365	240	180	185

* Recommended nominal diameter for duct.

Characteristic curves

Q = Airflow in m³/h, m³/s and cfm.

Pe = Static pressure in mm.w.c., Pa and in wg.

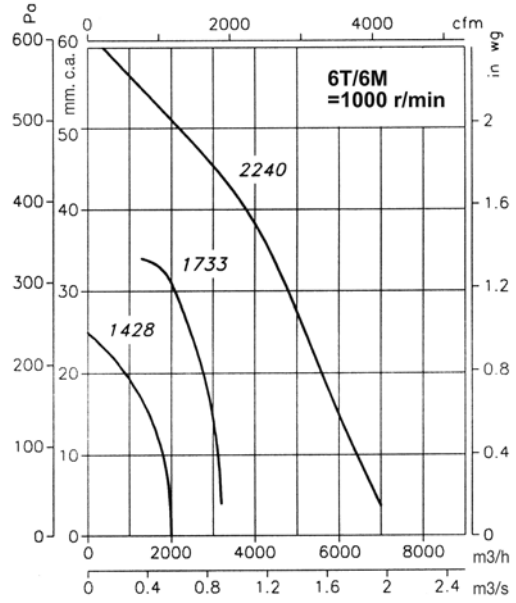
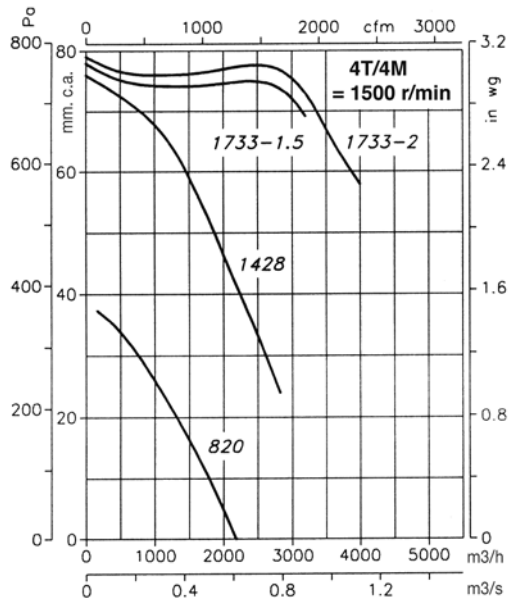

Positions

LG 270 standard supply



Accessories

See the accessories section.



CPV

Centrifugal anti-corrosive single-inlet fans made from polypropylene.



Aesthetic and modern design

Fan:

- Polypropylene casing
- Impeller with forward-facing blades made from polypropylene

Motor:

- Motors with IE-2 efficiency, except for motors with lower powers than 0.75 kW, monophase motors or two-speed motors
- Class F motors with ball bearings, IP55 protection
- Three-phase 230/400V.-50Hz. (up to 5.5CV.) and 400/690V.-50Hz. (power over 5.5CV.)
- Max. temperature of air for transport: -20°C.+ 50°C.

Finish:

- Plastic anticorrosive

On request:

- Special windings for different voltages
- ATEX certification, Category 3

Order code

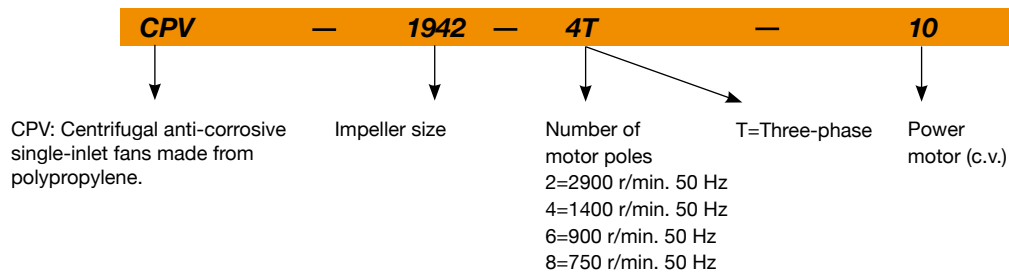

Technical characteristics

Model	Speed (r/min)	Maximum admissible current (A)			Installed Power (kW)	Maximum Airflow (m³/h)	Sound pressure level dB(A)	Approx. weight (Kg)
		230V	400V	690V				
CPV-815-2T	2810	1.73	1.00		0.37	950	75	14.0
CPV-815-4T	1360	1.32	0.76		0.25	450	58	14.0
CPV-1020-2T	2800	3.00	1.73		0.75	2000	81	19.5
CPV-1020-4T	1360	1.32	0.76		0.25	1250	65	19.5
CPV-1020-6T	880	1.67	0.96		0.25	750	53	19.5
CPV-1325-2T	2850	7.97	4.60		2.20	3250	87	27.0
CPV-1325-4T	1360	1.78	1.03		0.37	2300	69	27.0
CPV-1325-6T	880	1.67	0.96		0.25	1400	59	27.0
CPV-1630-4T	1420	5.98	3.45		1.50	4500	75	34.5
CPV-1630-6T	910	2.80	1.61		0.55	2700	63	34.5
CPV-1840-4T	1420	11.09	6.40		3.00	6000	70	48.0
CPV-1840-6T	900	5.04	2.90		1.10	4200	65	42.0
*CPV-1942-4T-7.5	1450		11.40	6.60	5.50	8500	79	66.0
*CPV-1942-4T-10	1450		15.10	8.70	7.50	10500	84	77.0
*CPV-1942-6T	930	9.32	5.36		2.20	7000	75	49.0
*CPV-1942-8T	710	7.10	4.08		1.50	5500	70	56.0
CPV-2045-4T	1450		15.10	8.70	7.50	10400	78	102.0
CPV-2045-6T	950	12.20	7.00		3.00	7000	72	88.0
*CPV-1030-2T	2900	19.23	11.10		4.00	2900	75	66.0
CPV-1335-2T	2915		14.70	8.50	5.50	4700	84	91.0
CPV-1160-4T	1460		21.50	12.40	11.00	8000	83	243.0
CPV-2060-4T	1460		21.50	12.40	11.00	12000	81	245.0
CPV-2160-4T	1455		28.50	16.50	15.00	15500	77	282.0
*CPV-720-2T	2840	1.82	1.05		0.37	525	75	10.0
*CPV-825-2T	2850	4.33	2.50		1.10	1140	79	17.0
*CPV-930-2T	2880	7.57	4.37		2.20	1750	84	24.0

*Only LG position allowed

Acoustic features

Sound power Lw(A) spectrum in dB(A) via frequency band in Hz.

Model	63	125	250	500	1000	2000	4000	8000	Model	63	125	250	500	1000	2000	4000	8000
815-2	56	69	77	81	81	77	73	65	1942-4-10	80	90	92	95	94	94	92	83
815-4	39	52	60	64	64	60	56	48	1942-6	71	81	83	86	85	85	83	74
1020-2	62	75	83	87	87	83	79	71	1942-8	66	76	78	81	80	80	78	69
1020-4	46	59	67	71	71	67	63	55	2045-4	63	76	84	88	89	85	81	72
1020-6	34	47	55	59	59	55	51	43	2045-6	57	70	78	82	83	79	75	66
1325-2	70	83	91	95	96	92	88	79	1030	58	71	79	83	84	80	76	67
1325-4	52	65	73	77	78	74	70	61	1335	67	80	88	92	93	89	85	76
1325-6	42	55	63	67	68	64	60	51	1160	68	81	89	93	94	90	86	77
1630-4	60	73	81	85	86	82	78	69	2060	66	79	87	91	92	88	84	75
1630-6	48	61	69	73	74	70	66	57	2160	64	77	85	89	89	85	81	73
1840-4	55	68	76	80	81	77	73	64	720	56	69	77	81	81	77	73	65
1840-6	50	63	71	75	76	72	68	59	825	60	73	81	85	85	81	77	69
1942-4-7,5	75	85	87	90	89	89	87	78	930	65	78	86	90	90	86	82	74

Dimensions in mm

CPV-720...1942

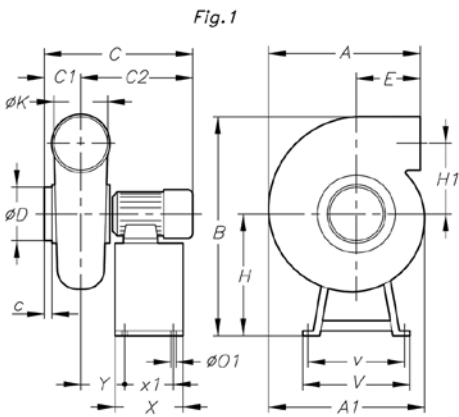

Model	Fig.	A	A1	B	C	C1	C2	c	øD	E	H	øK	øO1	V	v	X	x1	Y
CPV-720	1	375	-	456	350	80	270	45	90	212	281	90	8	355	335	180	160	92
CPV-815	1	303	335	521	371	100	271	30	125	100	281	125	8	355	335	180	160	90
CPV-825	1	445	-	522	433	110	323	55	125	218	290	125	8	355	335	180	160	103
CPV-930	1	540	-	658	477	100	377	40	160	262	370	160	8	400	380	180	160	117
CPV-1020-2T	1	340	397	584	440	116	324	32	160	100	281	160	8	355	335	180	160	121
CPV-1020-2T	1	340	397	584	413	116	297	32	160	100	281	160	8	355	335	180	160	116
CPV-1325-2T	1	413	505	735	487	130	357	35	200	103	370	200	8	400	380	180	160	126
CPV-1325	1	413	505	716	438	130	308	35	200	103	351	200	8	400	380	180	160	127
CPV-1630-4T	1	490	602	888	529	145	384	35	250	117	440	250	8	450	430	240	220	143
CPV-1630-6T	1	490	602	878	495	145	350	35	250	117	430	250	8	450	430	240	220	137
CPV-1942-4T	1	580	750	1170	792	210	642	60	315	130	600	315	8	600	564	350	314	188
CPV-1942-6T	1	580	750	1150	724	210	574	60	315	130	580	315	8	600	564	350	314	188
CPV-1942-8T	1	580	750	1150	724	210	574	60	315	130	580	315	8	600	564	350	314	188

CPV-1030..0.2045

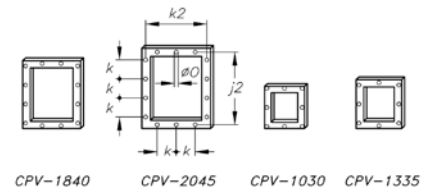
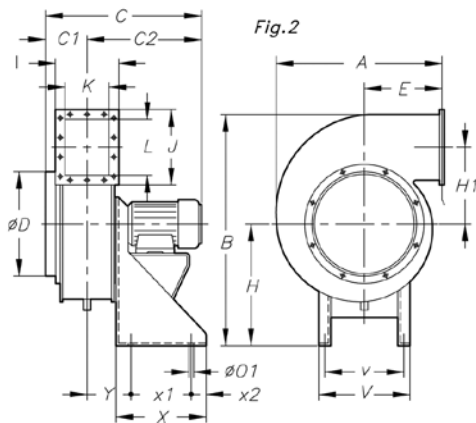

Model	Fig.	A	B	C	C1	C2	øD	E	H	I	J	J2	øK	k	k2	L	ø0	øO1	V	v	X	x1	x2	Y
CPV-1030	2	494	698	-	155	-	200	225	410	210	221	200	140	100	186	155	9	12	260	234	-	175	50	130
CPV-1335	2	566	788	-	175	-	225	255	452	240	256	226	160	100	210	180	9	12	320	285	-	200	50	140
CPV-1840-4T	2	631	819	660	210	450	355	275	420	305	356	326	225	100	275	280	9	12	320	285	300	200	50	170
CPV-1840-6T	2	631	809	630	210	420	355	275	410	305	356	326	225	100	275	280	9	12	320	285	300	200	50	170
CPV-2045	2	736	1020	810	245	565	400	310	542	362	421	381	270	100	322	335	9	12	350	315	350	250	50	195

Dimensions in mm

CPV-1160..0.2160

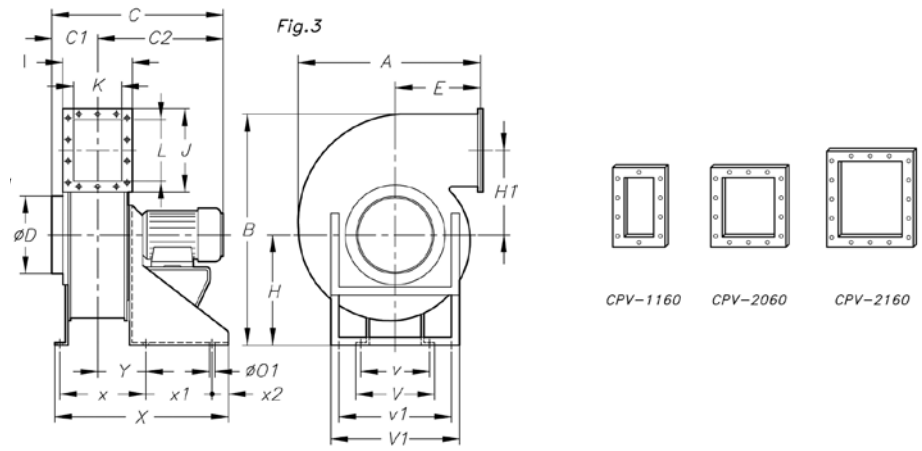

Model	Fig.	A	B	C1	øD	E	H	I	J	J2	øK	k	k2	L	ø0	ø01	V	V1	v	v1	X	x	x1	x2	Y
CPV-1160	3	937	1276	210	350	410	700	275	416	366	155	100	225	310	9	14	500	790	450	670	710	265	360	60	155
CPV-2060	3	937	1276	270	400	410	700	395	416	366	275	100	345	310	9	14	500	790	450	670	830	385	360	60	215
CPV-2160	3	981	1336	285	600	414	700	455	501	451	335	100	405	395	9	14	500	790	450	670	890	445	360	60	240

Characteristic curves

Q = Airflow in m³/h, m³/s and cfm.

Pe = Static pressure in mm.w.c., Pa and in wg.

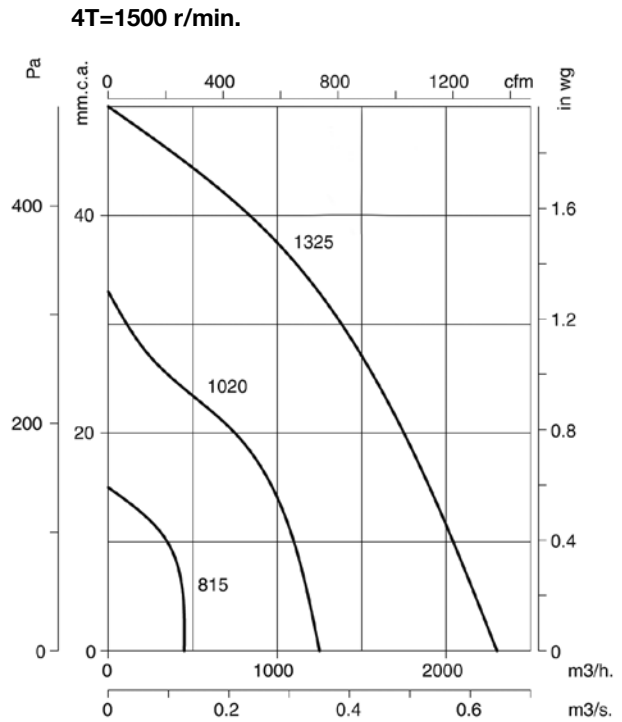
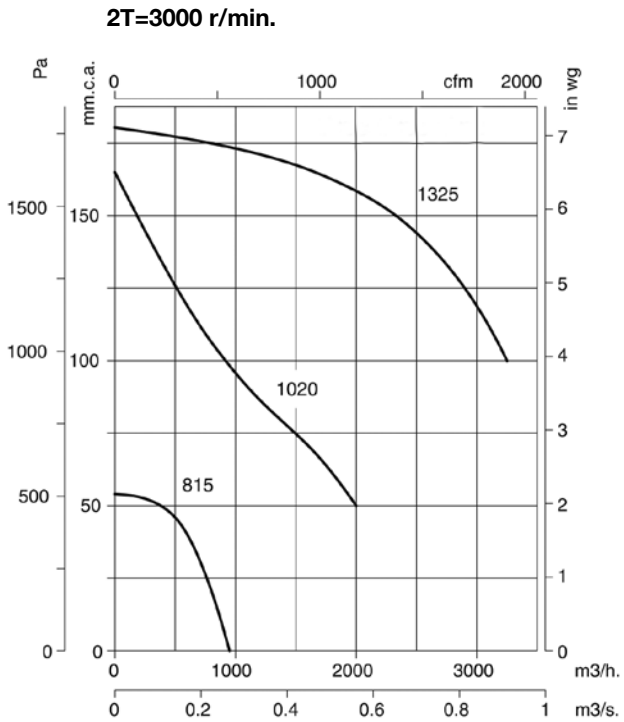

Characteristic curves

Q = Airflow in m³/h, m³/s and cfm.

Pe = Static pressure in mm.w.c., Pa and in wg.

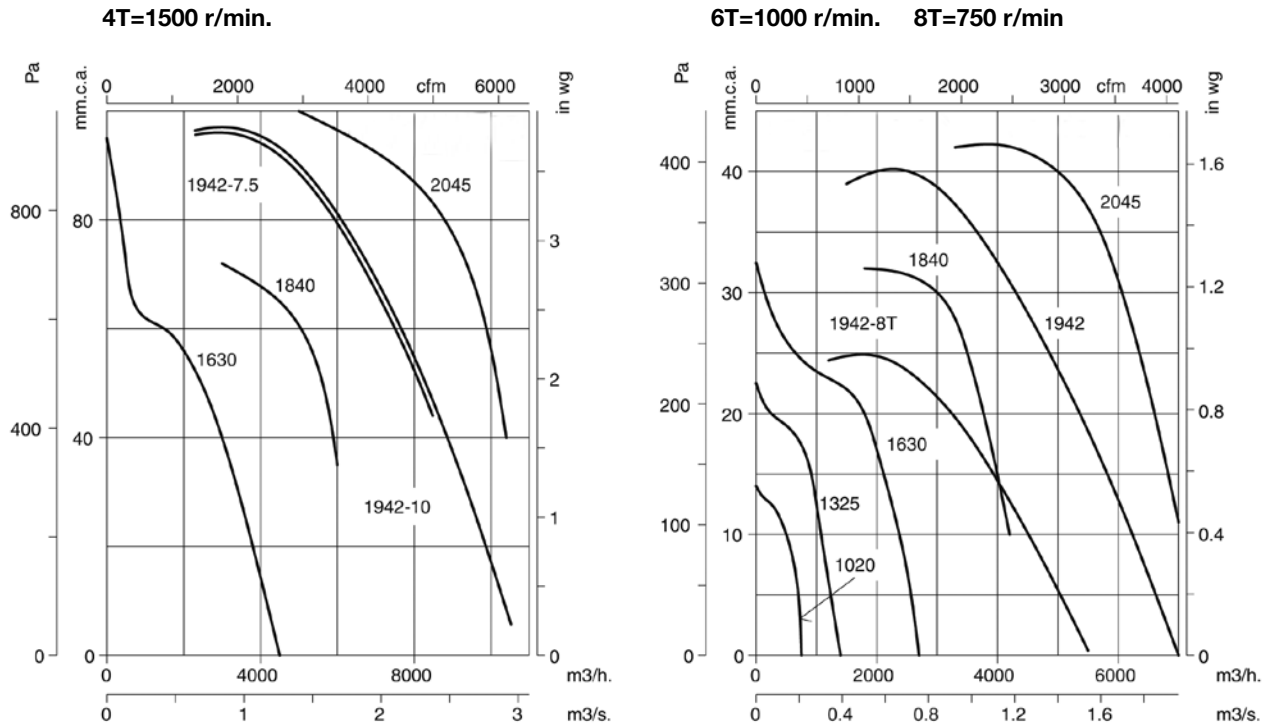

2T=3000 r/min. 4T=1500 r/min

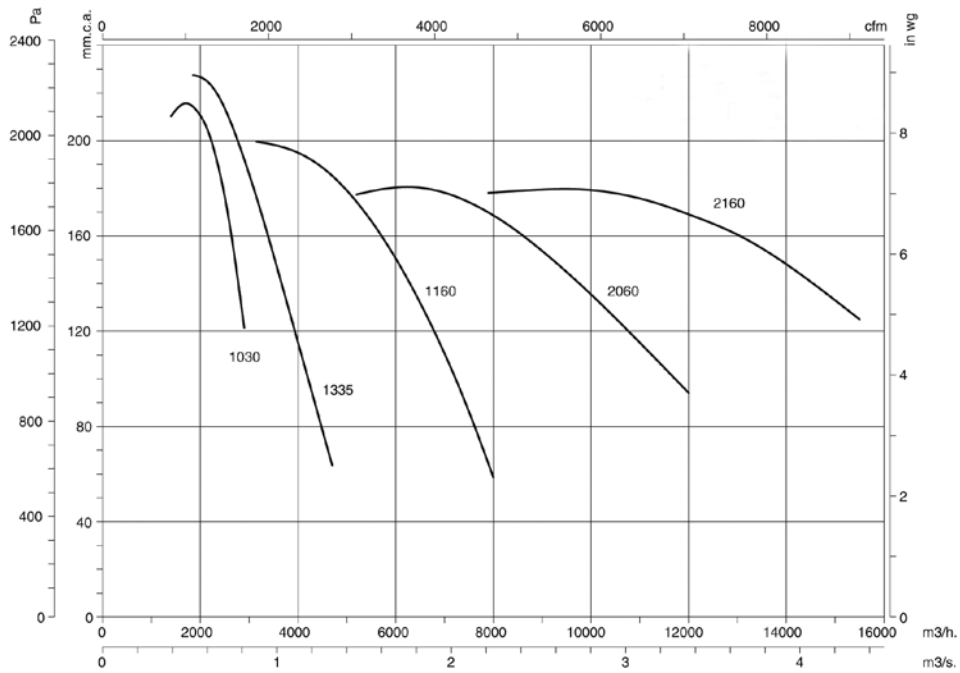

Characteristic curves

Q = Airflow in m³/h, m³/s and cfm.

Pe= Static pressure in mm.w.c., Pa and in wg.

2T=3000 r/min.

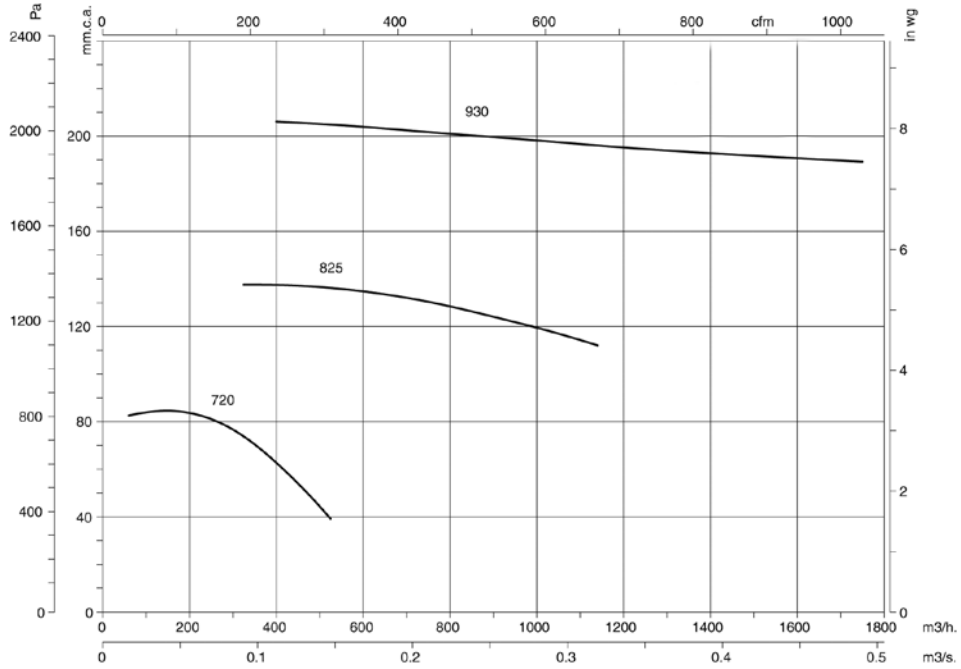

Positions

LG 90 standard supply



Accessories

See the accessories section.



CMA

Centrifugal single-inlet, medium-pressure fans with casing and impeller made from cast aluminium



Option of different impeller positions

Fan:

- Casing made from cast aluminium
- Impeller made from cast aluminium
- Models 324, 325 and 426 with polyamide impeller, model 531-2T-3 with sheet steel impeller

Motor:

- Motors with IE-2 efficiency, except for motors with lower powers than 0.75 kW, monophase motors or two-speed motors
- Class F motors with ball bearings, IP55 protection, except single-phase models which have IP54 protection
- Single-phase 230V.-50Hz., and three-phase 230/400V.-50Hz.
- Max. temperature of air for transport: -20°C.+ 120°C, maximum +70°C for models with polyamide impeller

Finish:

- Anticorrosive finish in polyester resin, polymerised at 190°C, after alkaline degreasing and phosphate-free pre-treatment.

On request:

- Special windings for different voltages
- Cast aluminium impellers for models 324, 325 and 426
- Fan designed to transport air up to 250°C
- ATEX Certification, category 2 (see CMA/ATEX series)

Order code



CMA: Centrifugal single-inlet, medium-pressure fans with casing and impeller made from cast aluminium

Impeller size

Number of motor poles
2=2900 r/min. 50 Hz

T=Three-phase
M=Single-phase

Power motor (c.v.)

Technical characteristics

Model	Speed (r/min)	Maximum admissible current (A)		Installed Power (kW)	Maximum Airflow (m³/h)	Sound pressure level dB(A)	Approx. weight (Kg)
		230V	400V				
CMA-218-2T	2920	0.61	0.35	0.09	265	63	6.0
CMA-218-2M	2920	0.60		0.09	265	63	6.0
CMA-324-2T	2850	1.21	0.70	0.18	440	70	9.0
CMA-324-2M	2850	1.50		0.18	440	70	9.0
CMA-325-2T	2780	1.64	0.95	0.25	600	73	11.0
CMA-325-2M	2780	2.20		0.25	600	73	11.0
CMA-426-2T	2765	1.78	1.03	0.37	850	75	13.0
CMA-426-2M	2765	2.95		0.37	850	75	13.0
CMA-527-2T	2800	2.42	1.40	0.55	1000	80	14.8
CMA-527-2M	2800	3.90		0.55	1000	80	14.8
CMA-528-2T-1	2780	3.12	1.80	0.75	1250	82	23.5
CMA-528-2M-1	2780	5.20		0.75	1250	82	23.5
CMA-528-2T-1.5	2850	4.42	2.55	1.10	1750	83	26.0
CMA-528-2M-1.5	2850	7.10		1.10	1750	83	26.0
CMA-531-2T-1.5	2880	4.42	2.55	1.10	1790	84	29.0
CMA-531-2M-1.5	2880	7.10		1.10	1790	84	29.0
CMA-531-2T-2	2850	5.89	3.40	1.50	2000	85	31.0
CMA-531-2M-2	2850	9.30		1.50	2000	85	31.0
CMA-531-2T-3	2800	8.23	4.75	2.20	2400	86	30.0
CMA-540-2T	2890	5.89	3.40	1.50	2600	85	38.0
CMA-545-2T-3	2840	8.23	4.75	2.20	2630	86	54.0
CMA-545-2T-4	2880	10.91	6.30	3.00	3550	88	64.0

Acoustic features

Sound power Lw(A) spectrum in dB(A) via frequency band in Hz.

Model	63	125	250	500	1000	2000	4000	8000	Model	63	125	250	500	1000	2000	4000	8000
218	29	43	61	67	71	68	63	54	531-1,5	50	64	82	88	92	89	84	75
324	36	50	68	74	78	75	70	61	531-2	51	65	83	89	93	90	85	76
325	39	53	71	77	81	78	73	64	531-3	52	66	84	90	94	91	86	77
426	41	55	73	79	83	80	75	66	540	54	67	85	91	96	92	87	79
527	46	60	78	84	88	85	80	71	545-3	55	68	86	92	97	93	88	80
528-1	48	62	80	86	90	87	82	73	545-4	57	70	88	94	99	95	90	82
528-1,5	49	63	81	87	91	88	83	74									

Dimensions in mm

CMA-218...531

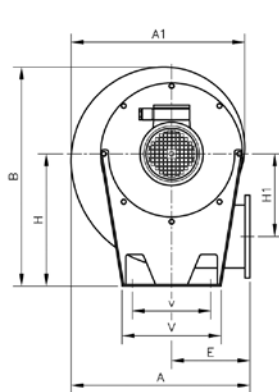
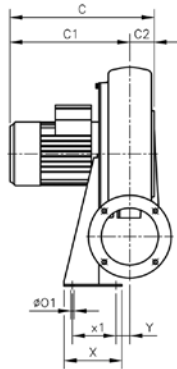

Inlet

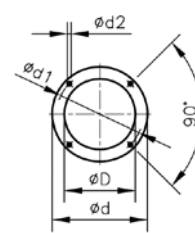

Outlet

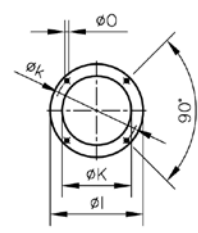

Model	A	A1	B	C	C1	C2	ØD	Ød	Ød1	Ød2	E	H	H1	ØI	ØK	Øk	ØO	ØO1	V	v	X	X1	Y
CMA-218	241	236	288	239	208	32	80	113	90	M5	110	170	114.5	90	54	76	5.5	7	140	100	80	50	20
CMA-324	311	302	356	268	202	38	80	130	112	M5	145	205	145	108	62	90	7	9	173	125	90	60	20
CMA-325	335	328	399	271	223	40	94	140	122	M6	155	235	152	120	80	102	7	9	180	145	110	80	20
CMA-426	354	344	412	291	250	40	117	155	132	M6	162	240	163	140	90	119	7	13	210	160	105	65	26
CMA-527	371	361	440	295	254	42	125	170	147	M6	168	260	170	155	100	129	7	13	220	170	120	80	20
CMA-528...1	401	395	488	340	289	51	116	190	162	M6	178	290	177	190	130	160	11	13	230	180	140	100	20
CMA-528...1'5	401	395	488	337	289	48	135	190	162	M6	178	290	177	190	130	160	11	13	230	180	140	100	20
CMA-531...1'5	440	434	537	341	290	50	160	215	180	M6	193	320	200	200	140	175	11	13	240	190	160	120	21
CMA-531...2	440	434	537	388	340	50	160	215	180	M6	193	320	200	200	140	175	11	13	240	190	160	120	21
CMA-531...3	440	434	537	388	350	50	160	215	180	M6	193	320	200	200	140	175	11	13	240	190	160	120	21

CMA-540-545

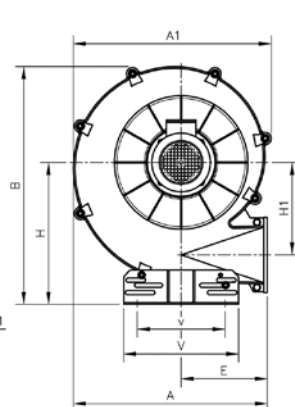
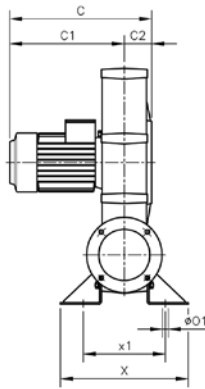

Inlet

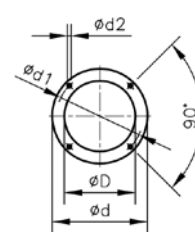

Outlet

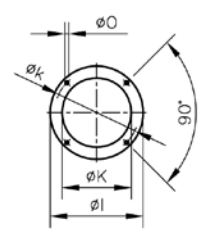

Model	A	A1	B	C	C1	C2	ØD	Ød	Ød1	Ød2	E	H	H1	ØI	ØK	Øk	ØO	ØO1	V	v	X	X1	Y
CMA-540	567	580	695	375	320	80	170	240	205	M10	252	415	270	220	150	190	13	11	336	218	374	240	-
CMA-545...3	651	646	776	423	344	115	180	255	220	M10	290	450	309	250	175	220	13	13	336	238	392	292	-
CMA-545...4	651	646	776	497	344	115	180	255	220	M10	290	450	309	250	175	220	13	13	336	238	392	292	-

Characteristic curves

Q = Airflow in m³/h, m³/s and cfm.

Pe= Static pressure in mm.w.c., Pa and in wg.

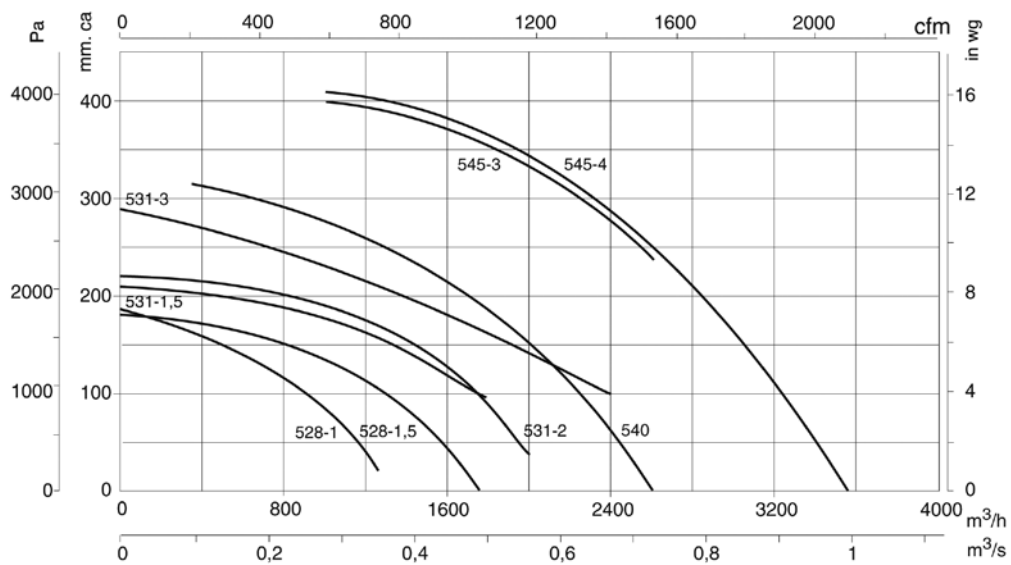
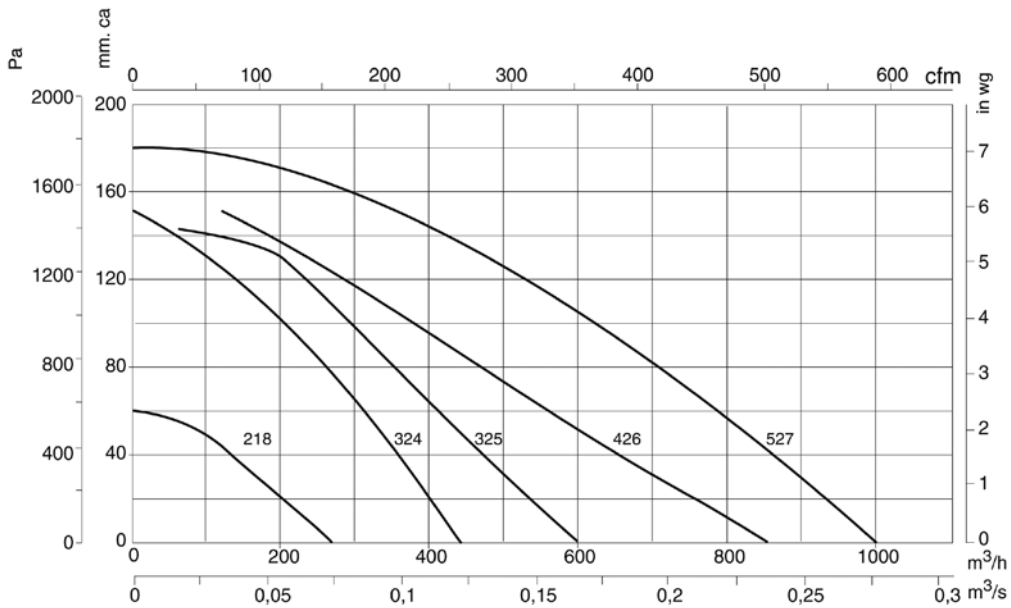

Positions

LG 270 standard supply

LG 180 position on request and with special fixing measures



Accessories

See the accessories section.



CMC

Centrifugal single-inlet, medium-pressure fans with casing and sheet steel impeller



Fan:

- Steel sheet casing
- Impeller with forward-facing blades made from galvanised sheet steel

Motor:

- Motors with IE-2 efficiency, except for motors with lower powers than 0.75 kW, monophase motors or two-speed motors
- Class F motors with ball bearings, IP55 protection
- Three-phase 230/400V.-50Hz
- Max. air temperature to transport: -20°C.+ 120°C.

Finish:

- Anticorrosive finish in polyester resin, polymerised at 190°C, after alkaline degreasing and phosphate-free pre-treatment.

On request:

- Special windings for different voltages
- Fan designed to transport air up to 250°C
- ATEX certification, Category 2

Fans without motor base support

Order code

CMC — **835** — **2T** — **3**

CMC: Centrifugal single-inlet, medium-pressure fans with casing and sheet steel impeller

Impeller size

Number of motor poles
T=2900 r/min. 50 Hz

T=Three-phase

Power motor (c.v.)

Technical characteristics

Model	Speed (r/min)	Maximum admissible current (A)		Installed Power (kW)	Maximum Airflow (m³/h)	Sound pressure level dB(A)	Approx. weight (Kg)
		230V	400V				
CMC-628-2T	2800	2.36	1.36	0.55	575	70	15.5
CMC-630-2T-1	2855	3.00	1.73	0.75	700	74	18.5
CMC-630-2T-1.5	2845	4.16	2.40	1.10	970	75	20.2
CMC-835-2T-2	2860	5.63	3.25	1.50	1050	79	29.5
CMC-835-2T-3	2880	7.97	4.60	2.20	1300	80	32.3
CMC-840-2T	2880	7.97	4.60	2.20	1170	82	32.5

Acoustic features

Sound power Lw(A) spectrum in dB(A) via frequency band in Hz.

Model	63	125	250	500	1000	2000	4000	8000	Model	63	125	250	500	1000	2000	4000	8000
628	43	53	74	73	77	75	69	60	835-2	61	65	80	78	86	85	82	77
630-1	41	57	76	71	81	81	74	67	835-3	62	66	81	79	87	86	83	78
630-1,5	42	58	77	72	82	82	75	68	840	48	70	82	81	90	88	85	80

Dimensions in mm

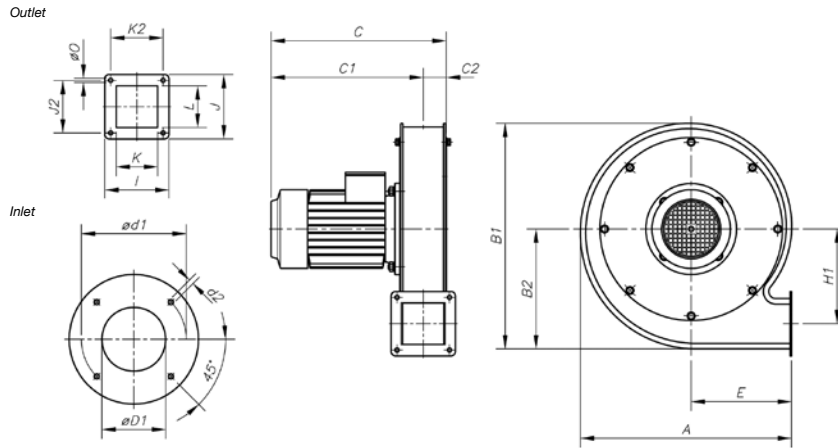

Model	A	B1	B2	C	C1	C2	ØD1	Ød1	Ød2	E	H1	I	J	J2	K	K2	L	Ø0
CMC-628-2T	377	393	207.5	308	259	49	120	192	M6	185	155	130	130	110	86	110	86	9
CMC-630-2T	403	426	226.5	332	283	46	130	192	M6	195	174	130	130	110	86	110	86	9
CMC-835-2T	468	494	262	385	334	51	140	230	M8	225	207	141	141	115	91	115	91	9
CMC-840-2T	528	55	289	385	334	51	162	230	M8	255	234	141	141	115	91	115	91	9

Characteristic Curves

Q = Airflow in m³/h, m³/s and cfm.

Pe = Static pressure in mm.w.c., Pa and in wg.

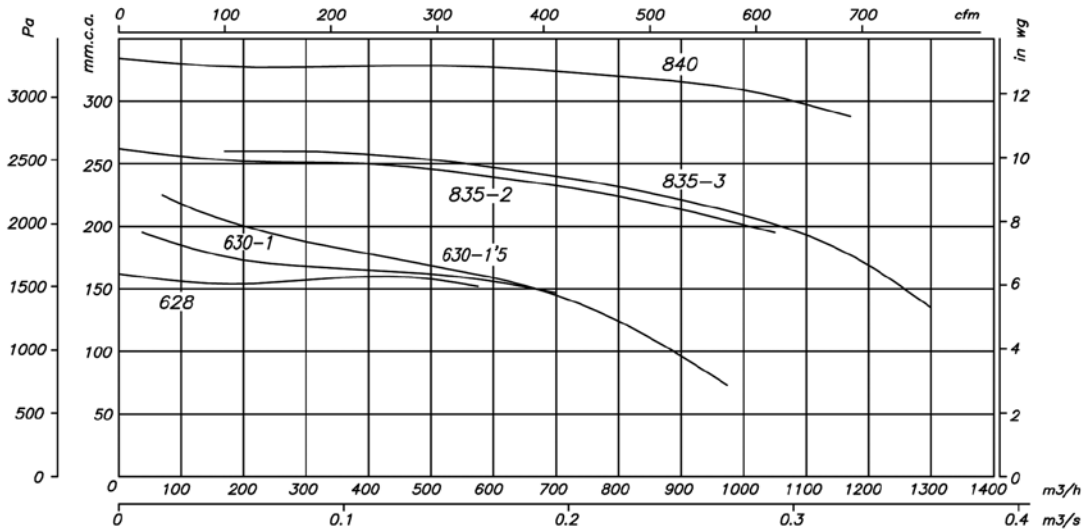

Accessories

See the accessories section.



CMP

Centrifugal single-inlet, medium-pressure fans with casing and sheet steel impeller



Dynamically balanced wheels with robust centres

Fan:

- Steel sheet casing
- Impeller with forward-facing blades made from galvanised sheet steel
- Model CMP 38-2M casing made from cast aluminium

Motor:

- Motors with IE-2 efficiency, except for motors with lower powers than 0.75 kW, monophase motors or two-speed motors
- Class F motors with ball bearings, IP55 protection, except single-phase models which have IP54 protection. Model CMP-38 IP21 protection
- Single-phase 230V -50Hz. and Three-phase 230/400V.50Hz. (up to 5.5CV) and 400/690V.-50Hz. (power over 5.5CV.)
- Max. air temperature to transport: -20°C.+ 120°C, maximum +100°C model CMP-38

Finish:

- Anticorrosive finish in polyester resin, polymerised at 190°C, after alkaline degreasing and phosphate-free pre-treatment.

On request:

- Special windings for different voltages
- Fan designed to transport air up to 250°C
- Stainless steel fans
- ATEX Certification, category 2 (see CMP/ATEX series)

Order code

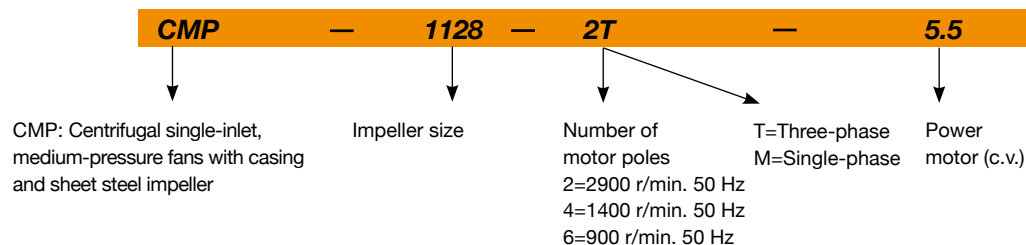

Technical characteristics

Model	Speed (r/min)	Maximum admissible current (A)			Installed Power (kW)	Maximum Airflow (m³/h)	Sound pressure level dB(A)	Approx. weight (Kg)
		230V	400V	690V				
CMP-38-2M/E	2650	0.54			0.01	135	50	2.0
CMP-38-2M	2600	0.54			0.01	160	50	2.0
CMP-512-2T	2850	0.55	0.32		0.08	490	62	4.0
CMP-512-2M	2900	0.60			0.08	490	62	4.0
CMP-512-4T	1440	0.55	0.32		0.05	255	55	3.5
CMP-512-4M	1440	0.60			0.05	255	55	3.5
CMP-514-2T	2850	1.21	0.70		0.18	800	65	5.0
CMP-514-2M	2700	1.80			0.18	800	65	5.0
CMP-514-4T	1440	0.55	0.32		0.08	565	58	4.5
CMP-514-4M	1440	0.60			0.08	565	58	4.5
CMP-616-2T	2740	1.73	1.00		0.55	1380	69	8.0
CMP-616-2M	2760	2.95			0.55	1380	69	9.5
CMP-616-4T	1400	0.65	0.37		0.10	850	61	7.5
CMP-616-4M	1400	0.72			0.10	850	61	7.5
CMP-620-2T	2740	1.73	1.00		0.37	765	68	9.5
CMP-620-2M	2760	2.95			0.37	765	68	10.0
CMP-620-4T	1375	0.69	0.40		0.10	810	61	7.5
CMP-620-4M	1375	0.76			0.10	810	61	7.5
CMP-718-2T	2855	3.00	1.73		0.75	1485	70	12.5

Technical characteristics

Model	Speed (r/min)	Maximum admissible current (A)			Installed Power (kW)	Maximum Airflow (m³/h)	Sound pressure level dB(A)	Approx. weight (Kg)
		230V	400V	690V				
CMP-718-2M	2750	5.20			0.75	1485	70	12.8
CMP-718-4T	1410	1.32	0.76		0.25	1280	63	9.5
CMP-718-4M	1410	1.40			0.25	1280	63	9.5
CMP-820-2T	2845	4.16	2.40		1.10	1950	73	15.0
CMP-820-2M	2850	7.10			1.10	1950	73	16.0
CMP-820-4T	1350	1.32	0.76		0.25	1670	66	10.0
CMP-820-4M	1400	2.00			0.25	1670	66	10.0
CMP-922-2T-1.5	2845	4.16	2.40		1.10	1650	70	20.0
CMP-922-2T-2	2860	5.63	3.25		1.50	2010	71	23.0
CMP-922-2T-3	2880	7.97	4.60		2.20	2600	74	25.5
CMP-922-4T	1395	2.51	1.45		0.55	2450	66	19.0
CMP-1025-2T-3	2880	7.97	4.60		2.20	2100	73	28.5
CMP-1025-2T-4	2895	10.57	6.10		3.00	2830	77	37.6
CMP-1025-4T	1410	4.59	2.65		1.10	3400	70	38.5
CMP-1128-2T-4	2895	10.57	6.10		3.00	2220	77	41.5
CMP-1128-2T-5.5	2900	13.34	7.70		4.00	3210	81	47.0
CMP-1128-4T	1420	8.49	4.90		2.20	5000	74	39.0
CMP-1128-6T	910	3.91	2.26		0.75	3300	60	28.5
CMP-1231-4T-3	1420	8.49	4.90		2.20	4740	73	47.0
CMP-1231-4T-4	1420	11.09	6.40		3.00	5910	75	49.0
CMP-1231-4T-5.5	1440	14.38	8.30		4.00	6850	77	56.0
CMP-1231-6T	940	7.48	4.30		1.50	5115	64	49.0
CMP-1435-4T-4	1420	11.09	6.40		3.00	5560	76	53.0
CMP-1435-4T-5.5	1440	14.38	8.30		4.00	6260	78	61.5
CMP-1435-4T-7.5	1455		11.40	6.60	5.50	7210	80	75.5
CMP-1435-6T	930	9.32	5.36		2.20	6400	66	58.5
CMP-1640-4T-5.5	1440	14.38	8.30		4.00	7500	77	78.5
CMP-1640-4T-7.5	1455		11.40	6.60	5.50	8035	80	92.5
CMP-1640-4T-10	1455		15.10	8.70	7.50	9710	82	103.5
CMP-1640-6T	930	9.32	5.36		2.20	8100	71	75.5
CMP-1845-4T-7.5	1455		11.40	6.60	5.50	8965	82	93.5
CMP-1845-4T-10	1455		15.10	8.70	7.50	10350	85	104.5
CMP-1845-6T	930	9.32	5.36		2.20	8330	77	84.0
CMP-2050-4T-10	1455		15.10	8.70	7.50	9000	83	134.0
CMP-2050-4T-12.5	1450		17.80	10.30	9.20	10730	85	137.0
CMP-2050-4T-15	1460		21.50	12.40	11.00	12525	87	153.0
CMP-2050-4T-20	1455		28.50	16.50	15.00	19000	89	172.0
CMP-2050-6T	940	15.60	8.95		4.00	11000	79	146.0
CMP-2563-6T	970		31.00	17.90	15.00	21000	86	251.0

Acoustic features

Sound power Lw(A) spectrum in dB(A) via frequency band in Hz.

Model	63	125	250	500	1000	2000	4000	8000	Model	63	125	250	500	1000	2000	4000	8000
38	25	35	46	53	57	54	52	45	1128-6	35	45	56	63	67	64	62	55
512-2	37	47	58	65	69	66	64	57	1231-4-3	51	60	71	78	82	80	78	71
512-4	30	40	51	58	62	59	57	50	1231-4-4	53	62	73	80	84	82	80	73
514-2	40	50	61	68	72	69	67	60	1231-4-5,5	55	64	75	82	86	84	82	75
514-4	33	43	54	61	65	62	60	53	1231-6	42	51	62	69	73	71	69	62
616-2	44	54	65	72	76	73	71	64	1435-4-4	54	63	74	81	85	83	81	74
616-4	36	46	57	64	68	65	63	56	1435-4-5,5	56	65	76	83	87	85	83	76
620-2	43	53	64	71	75	72	70	63	1435-4-7,5	58	67	78	85	89	87	85	78
620-4	36	46	57	64	68	65	63	56	1435-6	44	53	64	71	75	73	71	64
718-2	45	55	66	73	77	74	72	65	1640-4-5,5	55	64	75	82	86	84	82	75
718-4	38	48	59	66	70	67	65	58	1640-4-7,5	58	67	78	85	89	87	85	78
820-2	48	58	69	76	80	77	75	68	1640-4-10	60	69	80	87	91	89	87	80
820-4	41	51	62	69	73	70	68	61	1640-6	49	58	69	76	80	78	76	69
922-2-1,5	45	55	66	73	77	74	72	65	1845-4-7,5	61	71	82	89	93	91	89	81
922-2-2	46	56	67	74	78	75	73	66	1845-4-10	64	74	85	92	96	94	92	84
922-2-3	49	59	70	77	81	78	76	69	1845-6	56	66	77	84	88	86	84	76
922-4	41	51	62	69	73	70	68	61	2050-4-10	62	72	83	90	94	92	90	82
1025-2-3	48	58	69	76	80	77	75	68	2050-4-12,5	64	74	85	92	96	94	92	84
1025-2-4	52	62	73	80	84	81	79	72	2050-4-15	66	76	87	94	98	96	94	86
1025-4	45	55	66	73	77	74	72	65	2050-4-20	68	78	89	96	100	98	96	88
1128-2-4	52	62	73	80	84	81	79	72	2050-6	58	68	79	86	90	88	86	78
1128-2-5,5	56	66	77	84	88	85	83	76	2563-6	67	77	88	95	99	96	94	87
1128-4	49	59	70	77	81	78	76	69									

Dimensions in mm

CMP-38

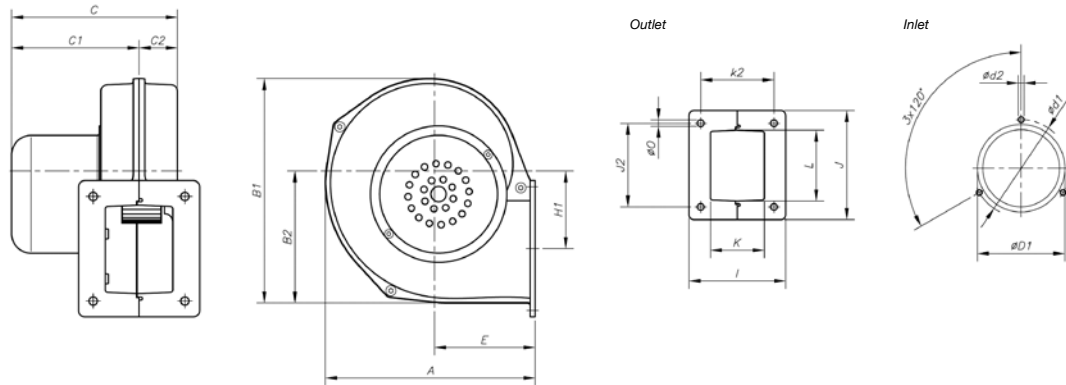

Model	A	B1	B2	C	C1	C2	øD1*	ød1	ød2	E	H1	I	J	J2	K	k2	L	øD
CMP-38-2M/E	141	165	97	122	96	26	80	85	2.4	60	60.5	100	80	46	50	77	52	8
CMP-38-2M	164.5	176.5	103.5	130	99	31	80	85	M4	79	64	95	107	82	53	72	67	6.5

* Recommended nominal diameter for duct.

CMP-512...820

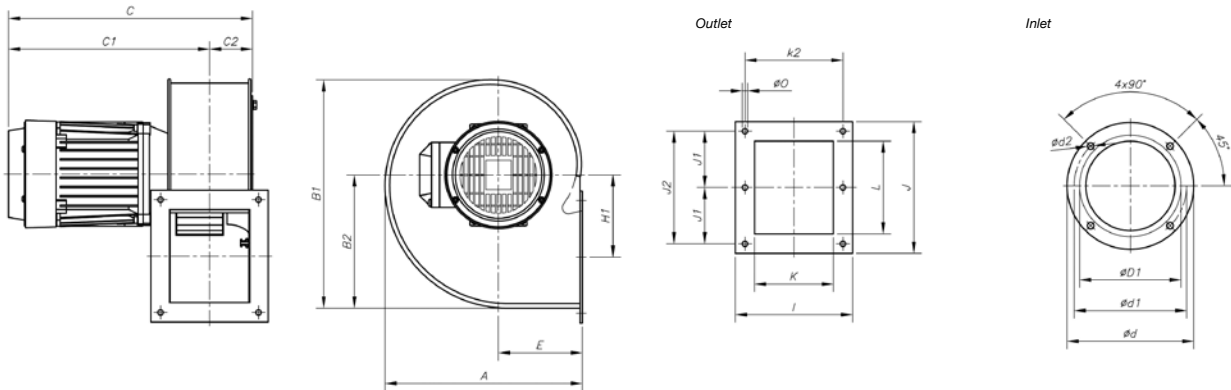

Model	A	B1	B2	C	C1	C2	øD1*	ød	ød1	ød2	E	H1	I	J	J1	J2	K	k2	L	øD
CMP-512-2T	185	206.5	118	251	212	39	112	140	132	M4	82.5	69	104	117	-	104.5	75	92	86	5.5
CMP-512-4T	185	206.5	118	249	210	39	112	140	132	M4	82.5	69	104	117	-	104.5	75	92	86	5.5
CMP-514-2T	225	254	150	281	236	45	140	169	151.5	M4	100	91	122	147	64	128	83	105	107	6.5
CMP-514-4T	225	254	150	261	216	45	140	169	151.5	M4	100	91	122	147	64	128	83	105	107	6.5
CMP-616-2T	258	297	173.5	320	264	56	160	204	180	M6	110	105.5	153	172	-	147	103	128	125	7
CMP-616-4T	258	297	173.5	283	227	56	160	204	180	M6	110	105.5	153	172	-	147	103	128	125	7
CMP-620-2T	298	347	202.5	321	265	56	200	247	230	M6	126	145.5	159	153	-	128	105	134	100	8
CMP-620-4T	298	347	202.5	283	227	56	200	247	230	M6	126	145.5	159	153	-	128	105	134	100	8
CMP-718-2T	303.5	348	201	355	294	61	180	238	210	M6	129.5	122	169	192	85	170	115	145	146	9
CMP-718-2M	303.5	348	201	355	245	61	180	238	210	M6	129.5	122	169	192	85	170	115	145	146	9
CMP-718-4T	303.5	348	201	331	270	61	180	238	210	M6	129.5	122	169	192	85	170	115	145	146	9
CMP-718-4M	303.5	348	201	331	270	61	180	238	210	M6	129.5	122	169	192	85	170	115	145	146	9
CMP-820-2T	322	377	223	369.5	301	68.5	200	247	230	M6	137.5	137	184	213	94.5	189	160	160	156	9
CMP-820-2M	322	377	223	369.5	301	68.5	200	247	230	M6	137.5	137	184	213	94.5	189	160	160	156	9
CMP-820-4T	322	377	223	345.5	277	68.5	200	247	230	M6	137.5	137	184	213	94.5	189	160	160	156	9
CMP-820-4M	322	377	223	345.5	277	68.5	200	247	230	M6	137.5	137	184	213	94.5	189	160	160	156	9

* Recommended nominal diameter for duct.

Dimensions in mm

CMP-922...1231

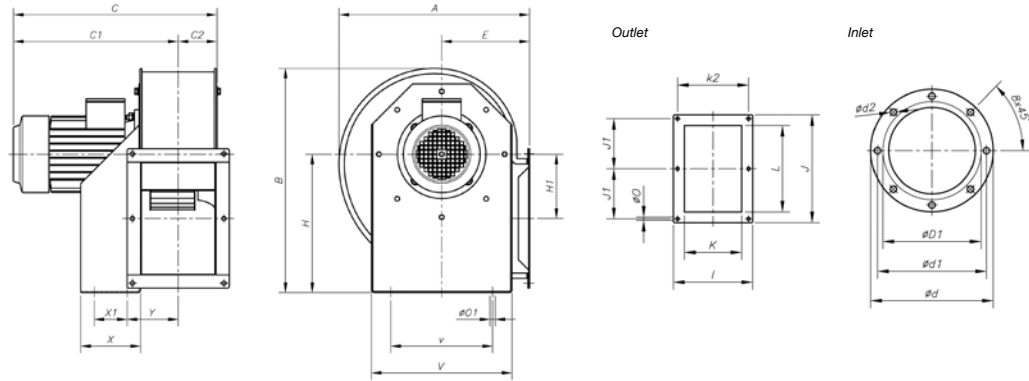

Model	A	B	C	C1	C2	øD1*	ød	ød1	ød2	E	H	H1	I	J	J1	K	k2	L	ø0	ø01	V	v	X	X1	Y
CMP-922-2T-1'5	388.5	455	382.5	309	73.5	224	278	256	M8	180	280	134	204	282.5	128	140	180	215	9.5	10.5	290	220	114	50	105
CMP-922-2T-2	388.5	455	430.5	357	73.5	224	278	25	M8	180	280	134	204	282.5	128	140	180	215	9.5	10.5	290	220	114	50	105
CMP-922-2T-3	388.5	455	430.5	357	73.5	224	278	256	M8	180	280	134	204	282.5	128	140	180	215	9.5	10.5	290	220	114	50	105
CMP-922-4T	388.5	455	382.5	309	73.5	224	278	256	M8	180	280	134	204	282.5	128	140	180	215	9.5	10.5	290	220	114	50	105
CMP-1025-2T-3	427	503	456	370	86	250	305	282	M8	197	310	144	229	312.5	145	165	205	250	9.5	12.5	315	228	134	74	115.5
CMP-1025-2T-4	427	503	486	400	86	250	305	282	M8	197	310	144	229	312.5	145	165	205	250	9.5	12.5	315	228	134	74	115.5
CMP-1025-4T	427	503	456	370	86	250	305	282	M8	197	310	144	229	312.5	145	165	205	250	9.5	12.5	315	228	134	74	115.5
CMP-1128-2T-4	472	553	500.5	407	93.5	280	348	320	M8	216	340	152	244	364	170	180	220	296.5	9.5	12.5	348	245	144	95	122.5
CMP-1128-2T-5'5	472	553	523.5	430	93.5	280	348	320	M8	216	340	152	244	364	170	180	220	296.5	9.5	12.5	348	245	144	95	122.5
CMP-1128-4T	472	553	500.5	407	93.5	280	348	320	M8	216	340	152	244	364	170	180	220	296.5	9.5	12.5	348	245	144	95	122.5
CMP-1128-6T	472	553	470.5	377	93.5	280	348	320	M8	216	340	152	244	364	170	180	220	296.5	9.5	12.5	348	245	144	95	122.5
CMP-1231-4T-3	526	630	520.5	417	103.5	315	382	354	M8	238	390	179.5	264	382.5	180	200	240	320	11.5	13	382	322	183	140	126
CMP-1231-4T-4	526	630	520.5	417	103.5	315	382	354	M8	238	390	179.5	264	382.5	180	200	240	320	11.5	13	382	322	183	140	126
CMP-1231-4T-5'5	526	630	543.5	440	103.5	315	382	354	M8	238	390	179.5	264	382.5	180	200	240	320	11.5	13	382	322	183	140	126
CMP-1231-6T	526	630	520.5	417	103.5	315	382	354	M8	238	390	179.5	264	382.5	180	200	240	320	11.5	13	382	322	183	140	126

* Recommended nominal diameter for duct.

CMP-1435...2563

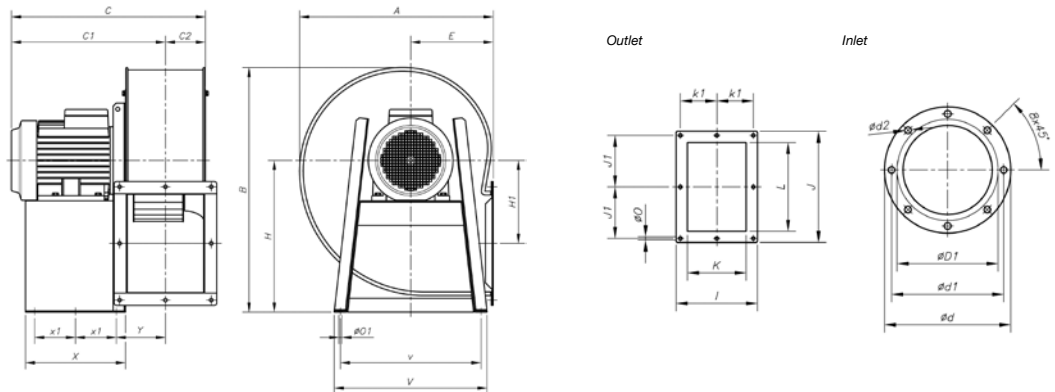

Model	A	B	C	C1	C2	øD1*	ød	ød1	ød2	E	H	H1	I	J	J1	K	k1	L	ø0	ø01	V	v	X	X1	Y
CMP-1435-4T-4	573.5	715	549	431	118	355	422	394	M8	250	445	242.5	292	342.5	159	228	133	280	11.5	12	456	420	333	136.5	150
CMP-1435-4T-5'5	573.5	715	572	454	118	355	422	394	M8	250	445	242.5	292	342.5	159	228	133	280	11.5	12	456	420	333	136.5	150
CMP-1435-4T-7'5	573.5	715	610	492	118	355	422	394	M8	250	445	242.5	292	342.5	159	228	133	280	11.5	12	456	420	333	136.5	150
CMP-1435-6T	573.5	715	572	454	118	355	422	394	M8	250	445	242.5	292	342.5	159	228	133	280	11.5	12	456	420	333	136.5	150
CMP-1640-4T-5'5	634	799	596	465	130	400	464	438	M8	270	495	271	336	404	185	250	150	321	11.5	12	500	460	327	133.5	162.5
CMP-1640-4T-7'5	634	799	634	504	130	400	464	438	M8	270	495	271	336	404	185	250	150	321	11.5	12	500	460	327	133.5	162.5
CMP-1640-4T-10	634	799	634	504	130	400	464	438	M8	270	495	271	336	404	185	250	150	321	11.5	12	500	460	327	133.5	162.5
CMP-1640-6T	634	799	596	466	130	400	464	438	M8	270	495	271	336	404	185	250	150	321	11.5	12	500	460	327	133.5	162.5
CMP-1845-4T-7'5	711	901	668	521	147	450	515	485	M8	302	560	305	370	444	202	284	164	361	11.5	12	538	502	340	140	179.5
CMP-1845-4T-10	711	901	668	521	147	450	515	485	M8	302	560	305	370	444	202	284	164	361	11.5	12	538	502	340	140	179.5
CMP-1845-6T	711	901	630	483	147	450	515	485	M8	302	560	305	370	444	202	284	164	361	11.5	12	538	502	340	140	179.5
CMP-2050-4T-10	797	987	700.5	538	162.5	500	565	535	M10	345	610	313	411	544	250	315	182.5	451	11.5	12	653	615	435	188	196
CMP-2050-4T-12'5	797	987	752.5	590	162.5	500	565	535	M10	345	610	313	411	544	250	315	182.5	451	11.5	12	653	615	435	188	196
CMP-2050-4T-15	797	987	805.5	643	162.5	500	565	535	M10	345	610	313	411	544	250	315	182.5	451	11.5	12	653	615	435	188	196
CMP-2050-4T-20	797	987	805.5	643	162.5	500	565	535	M10	345	610	313	411	544	250	315	182.5	451	11.5	12	653	615	435	188	196
CMP-2050-6T	797	987	700.5	538	162.5	500	565	535	M10	345	610	313	411	544	250	315	182.5	451	11.5	12	653	615	435	188	196
CMP-2563-6T	1027	1213	1016	805	211	630	710	675	M10	460	742	378	512	706	330	410	230	600	17	14	590	540	450	200	239

* Recommended nominal diameter for duct.

Characteristic curves

Q = Airflow in m³/h, m³/s and cfm.

Pe = Static pressure in mm.w.c., Pa and in wg.

CMP-38...820

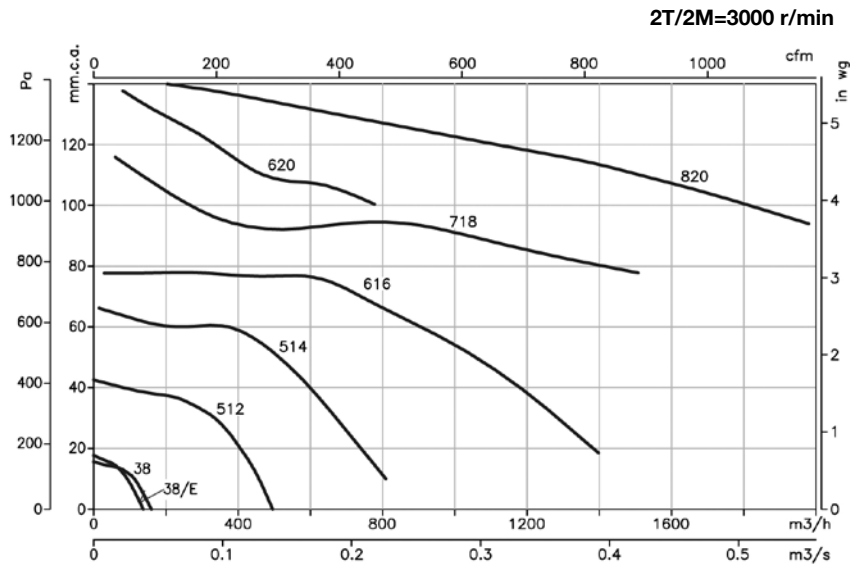

4T/4M=1500 r/min

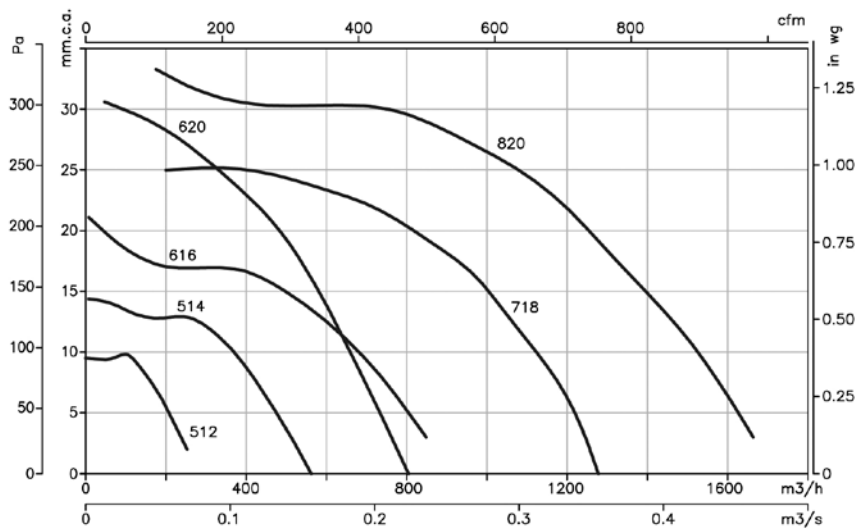

2T=3000 r/min

CMP-922...1231

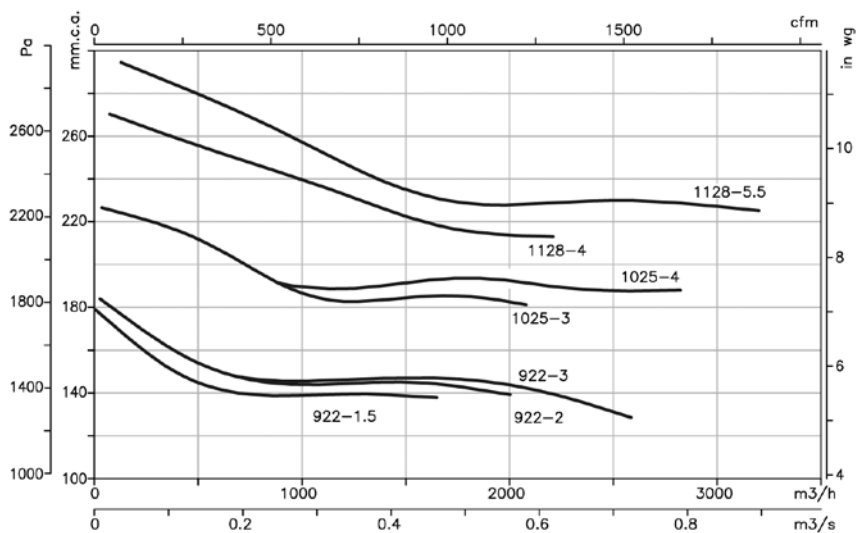

Characteristic curves

Q = Airflow in m³/h, m³/s and cfm.

Pe = Static pressure in mm.w.c., Pa and in wg.

4T=1500 r/min 6T=1000 r/min

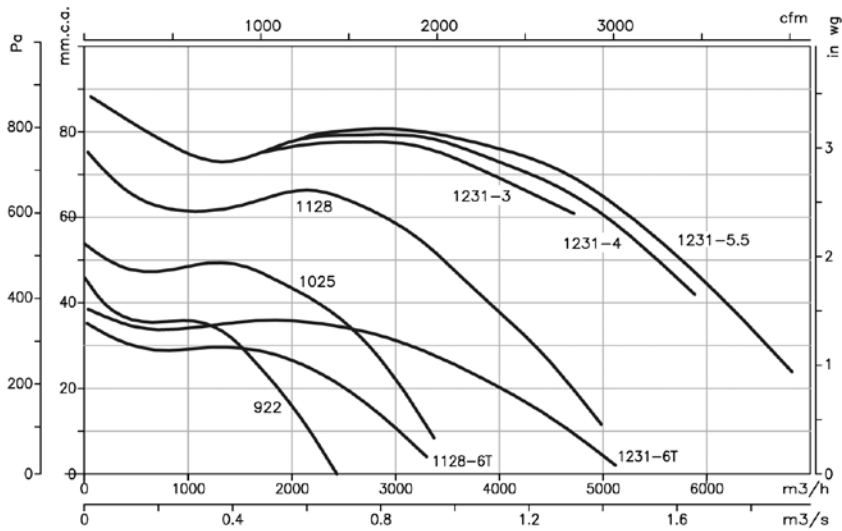

CMP-1435...2563

4T=1500 r/min

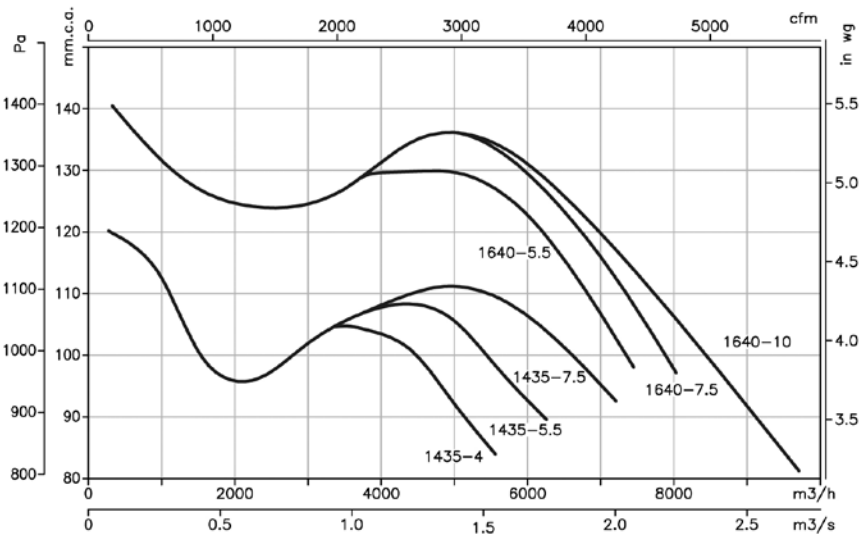

4T=1500 r/min

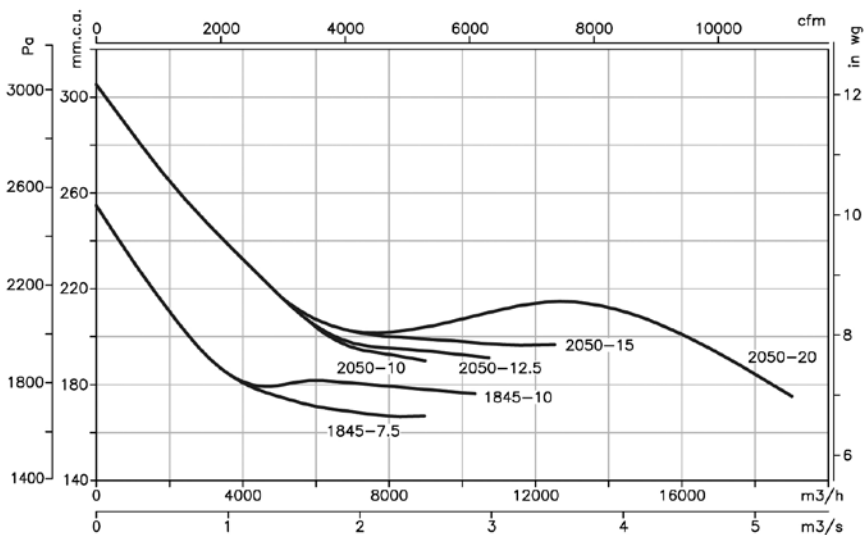

Characteristic curves

Q = Airflow in m³/h, m³/s and cfm.

Pe= Static pressure in mm.w.c., Pa and in wg.

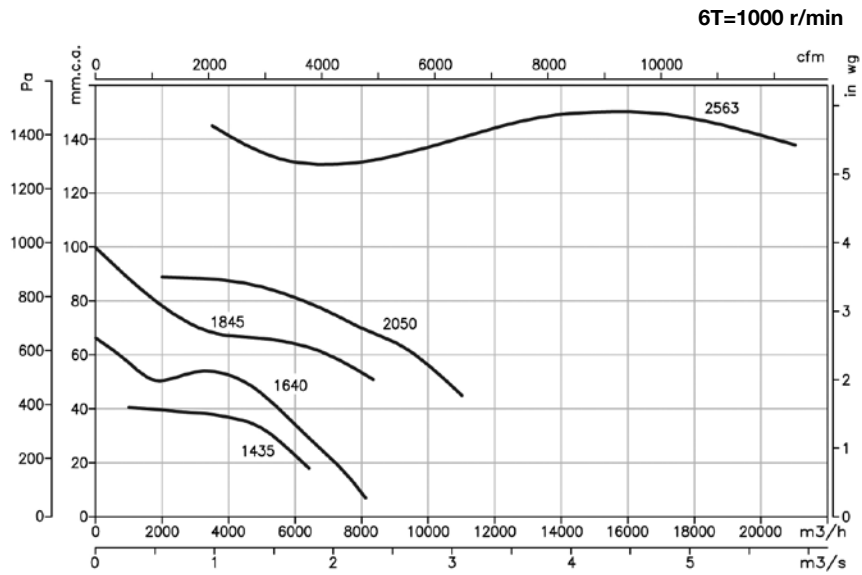

Positions

LG 270 standard supply

LG 180 and RD 180 positions on request and with special fixing measures.

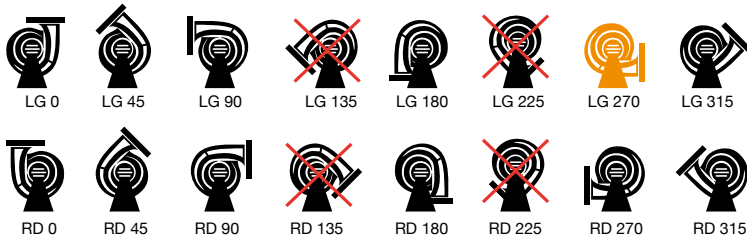

Accessories

See the accessories section.



Dimensions in mm

CMP/AL-512...820

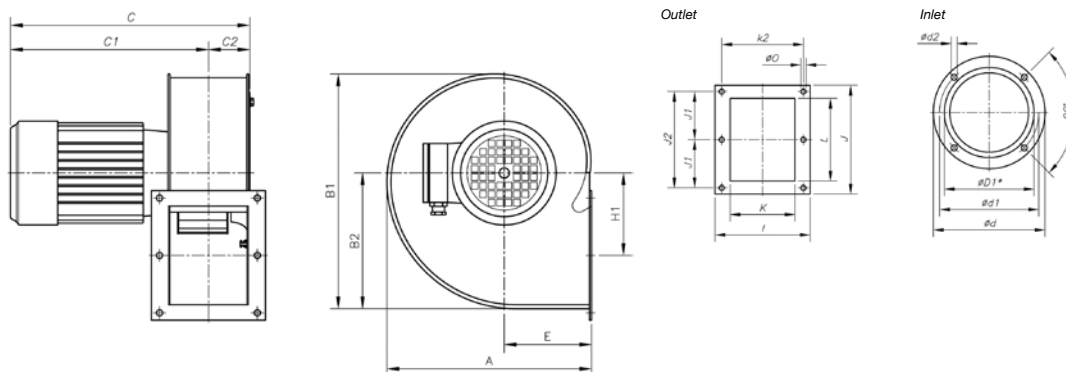

Model	A	B1	B2	C	C1	C2	øD1*	ød	ød1	ød2	E	H1	I	J	J1	J2	K	k2	L	øD
CMP-512-4M/AL	182	207	118	197.5	159	38.5	112	140	132	M4	81	69	106	118	-	105	72	93	86	5.5
CMP-514-4M/AL	225	254	150	210	165	45	140	169	151.5	M4	100	91	122	147	64	128	83	105	107	9.5
CMP-616-4M/AL	258	297	173.5	270	214	56	160	204	180	M6	110	105.5	153	172	-	147	103	128	125	7
CMP-820-4M/AL	322	377	223	345.5	277	68.5	200	247	230	M6	137.5	137	184	213	94.5	189	130	160	156	9

* Recommended nominal diameter for duct.

CJMP/AL-512...820

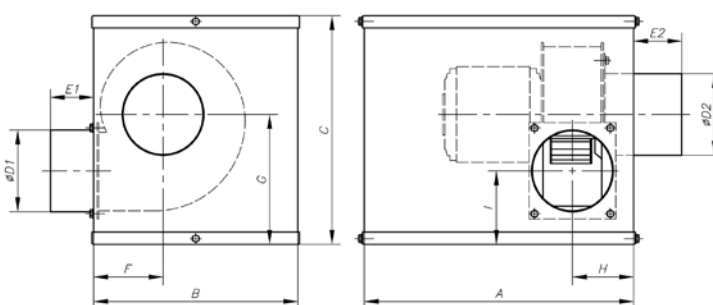

Model	A	B	C	øD1	øD2	E1	E2	F	G	H	I
CJMP/AL-512	330	250	280	100	100	53	59	85	159	75	90
CJMP/AL-514	330	270	320	125	125	53	58	104	190	82	100
CJMP/AL-616	370	300	370	135	135	53	52	114	217	100	110
CJMP/AL-820	450	400	450	135	195	53	51	142	267	112	130

Characteristic Curves

Q = Airflow in m³/h, m³/s and cfm.

Pe = Static pressure in mm.w.c., Pa and in wg.

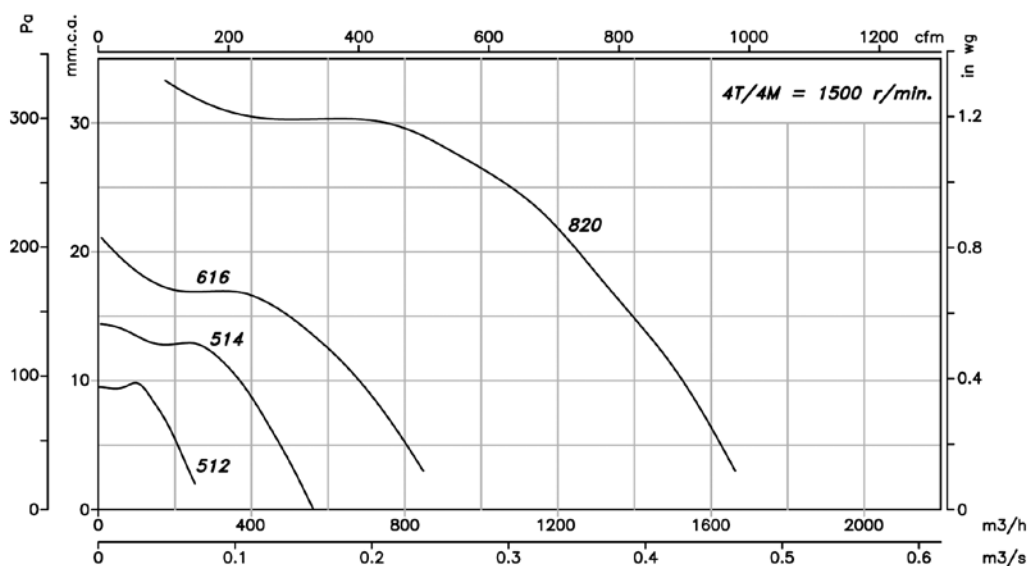

CMRE

Centrifugal single-inlet, medium-pressure fans fitted with an impeller with backward-facing blades and external rotor motor



- Fan:
- Steel sheet casing
 - Impeller with backward-curved blades



Different assembly positions

- Motor:
- Class F motors with external rotor incorporated thermal protector, ball bearings and IP54 protection
 - Single-phase 230V.-50/60Hz. adjustable
 - Max. air temperature to transport: + 50°C.

- Finish:
- Anticorrosive finish in polyester resin, polymerised at 190°C, after alkaline degreasing and phosphate-free pre-treatment.

Order code

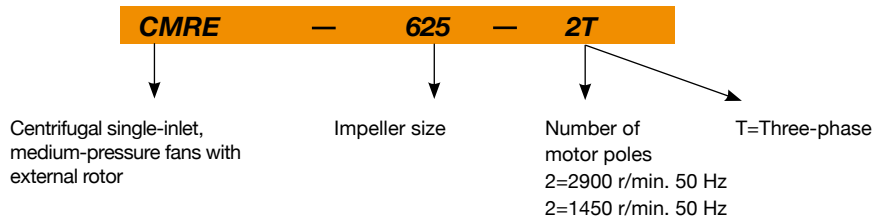

Technical characteristics

Model	Speed (r/min)	Maximum admissible current (A) 230V	Installed Power (kW)	Maximum Airflow (m ³ /h)	Irradiated sound level dB(A)	Weight approx. (Kg)
CMRE-622-2M	2380	0,85	0,12	1000	57	7,1
CMRE-625-2M	2360	0,95	0,14	1300	59	9,0
CMRE-1032-4M	1330	0,75	0,12	1800	61	12,7
CMRE-1036-4M	1280	0,95	0,14	2500	62	15,9

Dimensions in mm

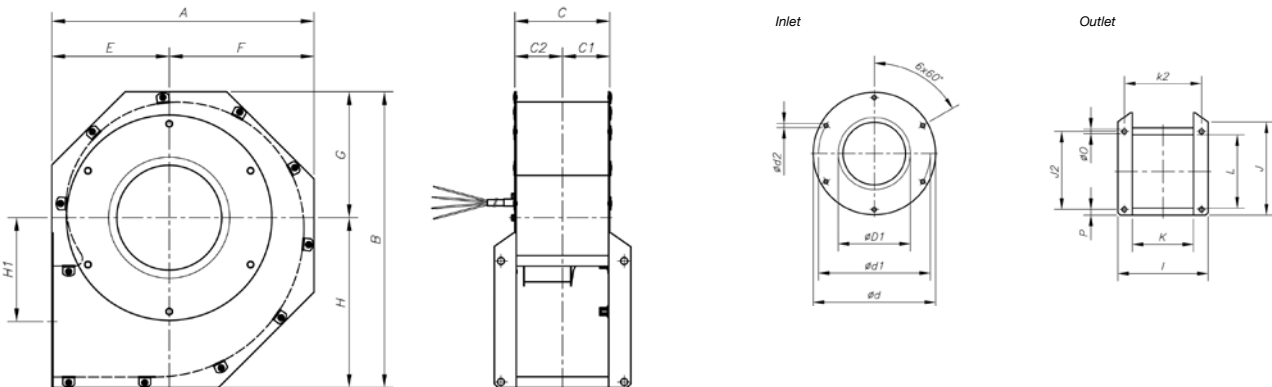

Model	A	B	C	C1	C2	øD1*	ød	ød1	ød2	E	F	G	H	H1	I	J	J2	K	k2	L	ø0	P
CMRE-622-2M	364	415.5	133	66.25	66.75	162	184	256	9.5	160	204	178	237.5	141.5	189.5	191	165	129.8	165.5	150.5	9	12
CMRE-625-2M	407	457	142	70.75	71.25	160	315	282	9.5	183	224	195.5	261.5	157	198.5	207	181.5	138.5	174.5	167.5	9	12
CMRE-1032-4M	507	564	198	99	99	192	382	354	9.5	230	277	240.5	323.5	197.5	254	250	227.5	194	230	211	9	12
CMRE-1036-4M	560	631	215.5	107.75	107.75	290	426	394	9.5	250	310	268.5	362.5	223	285.5	272.5	247	211.5	261.5	238	11	12

* Recommended nominal diameter for duct.

Characteristic Curves

Q = Airflow in m³/h, m³/s and cfm.

Pe = Static pressure in mm.w.c., Pa and in wg.

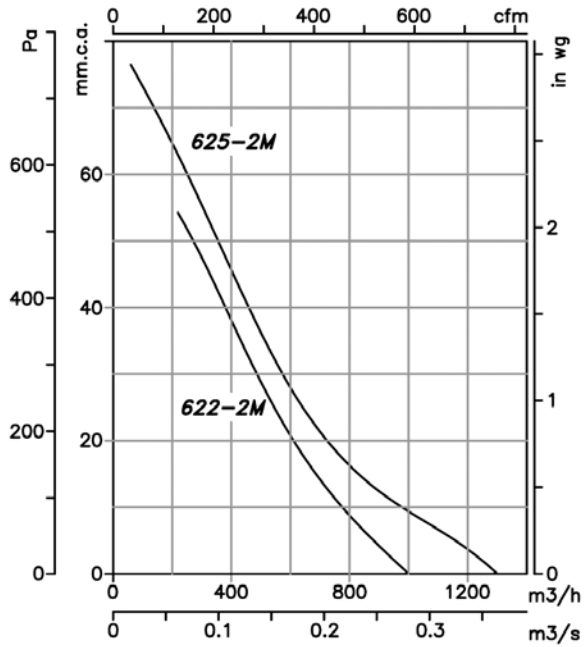

Accessories

See the accessories section.



CMR

Robust centrifugal single-inlet, medium-pressure fans fitted with an impeller with backward-facing blades



CMR



CMR
Size 622 to 731

Fan:

- Steel sheet casing
- Impeller with backward-curved blades made from robust sheet steel

Motor:

- Motors with IE-2 efficiency, except for motors with lower powers than 0.75 kW, monophase motors or two-speed motors
- Class F motors with ball bearings, IP55 protection
- Three-phase 230/400V.-50Hz. (up to 5.5CV.) and 400/690V.-50Hz. (power over 5.5CV.)
- Max. air temperature to transport: -20°C.+ 120°C.

Finish:

- Anticorrosive finish in polyester resin, polymerised at 190°C, after alkaline degreasing and phosphate-free pre-treatment.

On request:

- Special windings for different voltages.
- Fan designed to transport air up to 250°C.
- Stainless steel fans
- ATEX Certification, category 2 (see CMR/ATEX series)



Different assembly positions



High-performance and robust backward-curved impeller.

Order code

CMR — 1650 — 2T

CMR: Centrifugal single-inlet, medium-pressure fans

Impeller size

Number of motor poles

- 2=2900 r/min. 50 Hz
- 4=1400 r/min. 50 Hz
- 6=900 r/min. 50 Hz
- 8=750 r/min. 50 Hz

T=Three-phase

Technical characteristics

Model	Speed (r/min)	Maximum admissible current (A)			Installed Power (kW)	Maximum Airflow (m³/h)	Sound pressure level dB(A)	Approx. weight (Kg)
		230V	400V	690V				
CMR-622-2T	2930	1.23	0.71		0.25	1040	74	11.6
CMR-625-2T	2930	1.67	0.97		0.33	1280	75	13.7
CMR-728-2T	2930	2.45	1.42		0.50	1800	76	17.6
CMR-731-2T	2930	3.06	1.77		0.75	2350	77	22.8
CMR-1031-2T	2900	5.63	3.25		1.50	5160	80	44.3
CMR-1135-2T	2900	7.88	4.55		2.20	7800	83	54.9
CMR-1240-2T	2895	13.51	7.80		4.00	11100	86	93.5
CMR-1240-4T	1455	3.22	1.86		0.75	5800	71	70.5
CMR-1445-2T	2915		13.90	8.00	7.50	16500	87	126.0
CMR-1445-4T	1460	4.42	2.55		1.10	8030	72	92.5
CMR-1650-2T	2910		20.00	11.50	11.00	18850	89	178.0
CMR-1650-4T	1440	5.89	3.40		1.50	10500	74	114.0
CMR-1650-6T	970	3.91	2.26		0.75	7410	64	114.0
CMR-1856-4T	1455	11.09	6.40		3.00	15150	79	152.0
CMR-1856-6T	965	5.04	2.90		1.10	10050	70	146.5
CMR-2063-4T	1460		11.40	6.60	5.50	24450	80	226.0
CMR-2063-6T	935	7.48	4.30		1.50	16100	71	208.5

Technical characteristics

Model	Speed (r/min)	Maximum admissible current (A)			Installed Power (kW)	Maximum Airflow (m³/h)	Sound pressure level dB(A)	Approx. weight (Kg)
		230V	400V	690V				
CMR-2063-8T	725	5.90	3.39		1.10	11600	65	210.5
CMR-2271-4T	1465		21.50	12.40	11.00	34610	85	315.0
CMR-2271-6T	950	12.20	6.82		3.00	22750	76	293.5
CMR-2271-8T	720	7.10	4.08		1.50	17360	69	275.5
CMR-2380-4T	1400		41.00	23.70	22.00	48000	83	416.0
CMR-2380-6T	900		15.40	8.90	7.50	30000	75	363.0
CMR-2380-8T	700	12.80	7.38		3.00	22000	66	317.0
CMR-2590-4T	1475		68.00	39.30	37.00	54000	86	418.0
CMR-2590-6T	970		23.00	13.30	11.00	34000	76	378.0
CMR-28100-4T	1475		98.00	56.60	55.00	75000	87	553.0
CMR-28100-6T	985		36.00	20.80	18.50	48000	77	521.0

Acoustic features

The specified values are determined according to free field measurements of pressure and sound levels in dB(A) at an equivalent distance of twice the fan's span plus the turbine's diameter, with a minimum of 1.5 m.

Sound power Lw(A) spectrum in dB(A) via frequency band in Hz.

Model	63	125	250	500	1000	2000	4000	8000	Model	63	125	250	500	1000	2000	4000	8000
622-2T	59	72	72	85	80	80	80	73	1856-6	61	69	81	83	80	81	71	60
625-2T	60	73	73	86	81	81	81	74	2063-4	80	85	91	93	91	88	81	73
728-2T	61	74	74	87	82	82	82	75	2063-6	69	70	82	82	81	83	73	63
731-2T	62	75	75	88	83	83	83	76	2063-8	64	70	77	76	77	74	66	57
1031-2	65	78	78	91	86	86	86	79	2271-4	83	84	93	96	98	99	95	82
1135-2	72	79	77	89	87	93	92	79	2271-6	73	73	87	86	90	90	79	68
1240-2	68	83	81	93	90	94	96	83	2271-8	68	73	78	85	81	80	70	59
1240-4	56	70	76	79	79	80	70	59	2380-4	76	78	94	91	96	97	93	82
1445-2	73	85	83	95	93	97	99	89	2380-6	68	70	86	83	88	89	85	74
1445-4	59	72	78	83	80	83	78	64	2380-8	59	61	77	74	79	80	76	65
1650-2	73	81	85	99	97	99	99	88	2590-4	79	84	97	100	96	89	84	66
1650-4	64	74	82	84	83	85	76	66	2590-6	70	79	89	88	85	84	74	68
1650-6	53	65	72	77	73	69	62	54	28100-4	82	89	101	102	97	93	87	78
1856-4	69	78	91	87	90	91	85	71	28100-6	73	82	91	90	88	86	77	70

Dimensions in mm

CMR-622...731

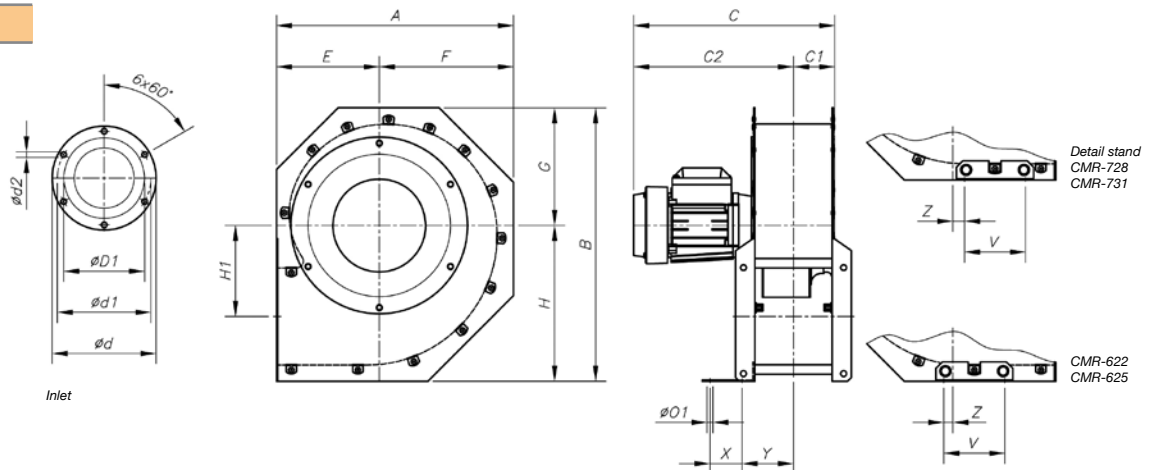

Model	A	B	C	C1	C2	øD1*	ød	ød1	ød2	E	F	G	H	H1	øO1	V	X	Y	Z
CMR-622-2T	364	415.5	338.5	64	274.5	162	284	256	9.5	160	204	178	237.5	141.5	9	95	50	80	14
CMR-625-2T	407	457	343.5	66.5	277	160	315	282	9.5	183	224	195.5	261.5	155	9	95	50	82.5	6
CMR-728-2T	453.5	506.5	357.5	72.5	285	192	354	320	9.5	205	248.5	216	290.5	176	9	95	50	88.2	6.5
CMR-731-2T	507	564	374	70	304	192	382	354	9.5	230	277	240.5	323.5	197.5	9	95	50	85.2	20.5

* Recommended nominal diameter for duct.

Dimensions in mm

CMR-1031...2271

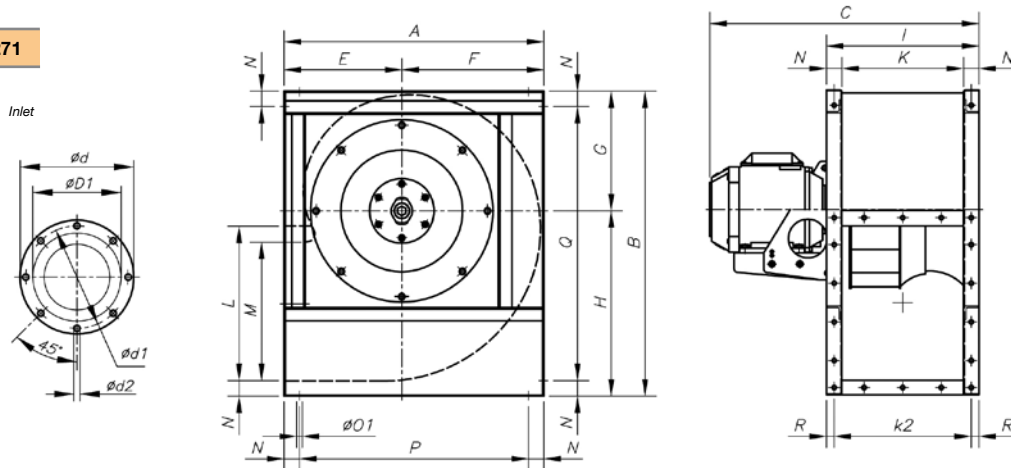

Model	A	B	C	$\phi D1^*$	ϕd	$\phi d1$	$\phi d2$	E	F	G	H	I	K	k2	L	M	N	$\phi O1$	P	Q	R
CMR-1031-2T	542	626	567	315	383	356	M8	250	292	245	381	320	250	285	315	276	35	11	472	556	17.5
CMR-1135-2T	600	696	583	355	425	398	M8	275	325	273	423	350	280	315	355	310	35	11	530	626	17.5
CMR-1240-2T	673	790	728	400	472	444	M10	305	368	310	480	395	315	355	400	358	40	11	593	710	20
CMR-1240-4T	673	790	590	400	472	444	M10	305	368	310	480	395	315	355	400	358	40	11	593	710	20
CMR-1445-2T	765	880	810	450	522	494	M10	350	415	339	541	445	355	405	450	404	45	11	675	790	20
CMR-1445-4T	765	880	649	450	522	494	M10	350	415	339	541	445	355	405	450	404	45	11	675	790	20
CMR-1650-2T	832	970	961	500	582	555	M10	375	457	378	592	490	400	450	500	445	45	13	742	880	20
CMR-1650-4T	832	970	715	500	582	555	M10	375	457	378	592	490	400	450	500	445	45	13	742	880	20
CMR-1650-6T	832	970	695	500	582	555	M10	375	457	378	592	490	400	450	500	445	45	13	742	880	20
CMR-1856-4T	925	1084	832	560	645	615	M10	415	510	426	658	550	450	500	560	493	50	13	825	984	25
CMR-1856-6T	925	1084	771	560	645	615	M10	415	510	426	658	550	450	500	560	493	50	13	825	984	25
CMR-2063-4T	1037	1218	973	630	720	688	M10	465	572	477	741	620	500	560	630	530	60	13	917	1098	30
CMR-2063-6T	1037	1218	893	630	720	688	M10	465	572	477	741	620	500	560	630	530	60	13	917	1098	30
CMR-2063-8T	1037	1218	893	630	720	688	M10	465	572	477	741	620	500	560	630	530	60	13	917	1098	30
CMR-2271-4T	1173	1375	1126	710	800	768	M12	525	648	538	837	690	560	625	710	603	65	13	1043	1245	32.5
CMR-2271-6T	1173	1375	1039	710	800	768	M12	525	648	538	837	690	560	625	710	603	65	13	1043	1245	32.5
CMR-2271-8T	1173	1375	1002	710	800	768	M12	525	648	538	837	690	560	625	710	603	65	13	1043	1245	32.5

* Recommended nominal diameter for duct.

CMR-2380...28100

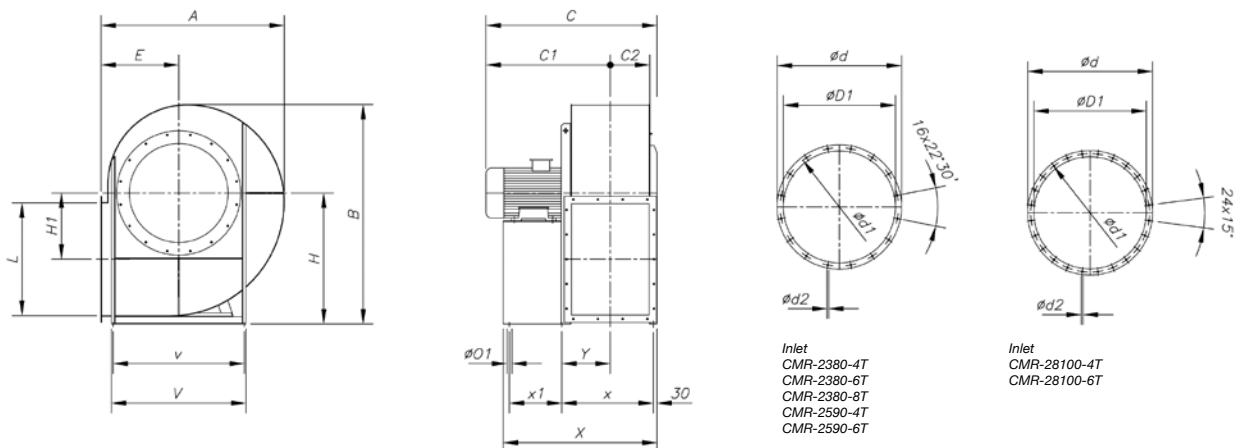

Model	A	B	C	C1	C2	$\phi D1^*$	ϕd	$\phi d1$	$\phi d2$	E	H	H1	L	$\phi O1$	V	v	X	x	x1	Y
CMR-2380-4T	1350	1660	1245	899	286	808	906	861	11.5	560	1000	500	800	17	930	870	1102.5	667.5	370	352.5
CMR-2380-6T	1350	1660	1030	744	286	808	906	861	11.5	56	1000	500	800	17	930	870	1102.5	667.5	370	352.5
CMR-2380-8T	1350	1660	1035	681	286	808	906	861	11.5	560	1000	500	800	17	930	870	1102.5	667.5	370	352.5
CMR-2590-4T	1495	1785	1390	1012	321	908	1008	958	14	630	1060	535	900	19	1030	970	1246	425	751	393
CMR-2590-6T	1495	1785	1235	857	321	908	1008	958	14	630	1060	535	900	19	1030	970	1121	340	721	373
CMR-28100-4T	1680	1990	1470	1051	362	1008	1108	1067	14	710	1180	610	1000	19	1130	1060	1378	460	843	454
CMR-28100-6T	1680	1990	1395	976	362	1008	1108	1067	14	710	1180	610	1000	19	1130	1060	1278	385	823	434

* Recommended nominal diameter for duct.

Dimensions in mm

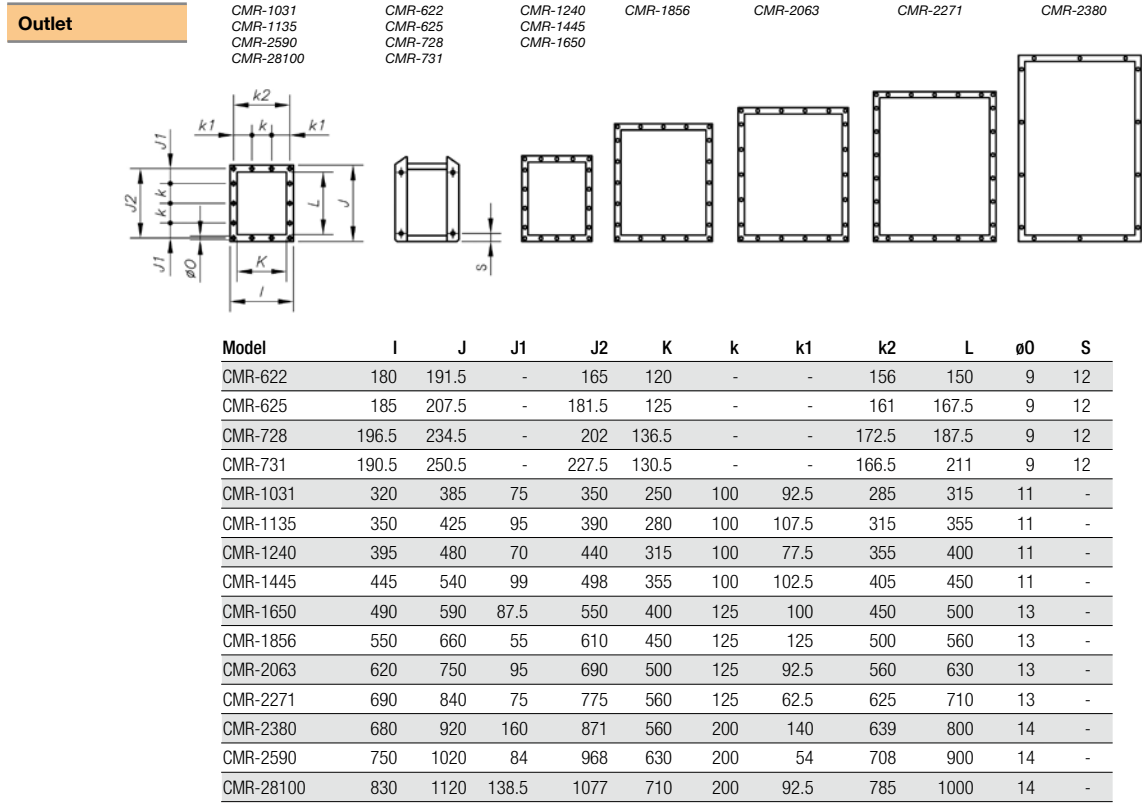

Characteristic Curves

Q = Airflow in m³/h, m³/s and cfm.

Pe = Static pressure in mm.w.c., Pa and in wg.

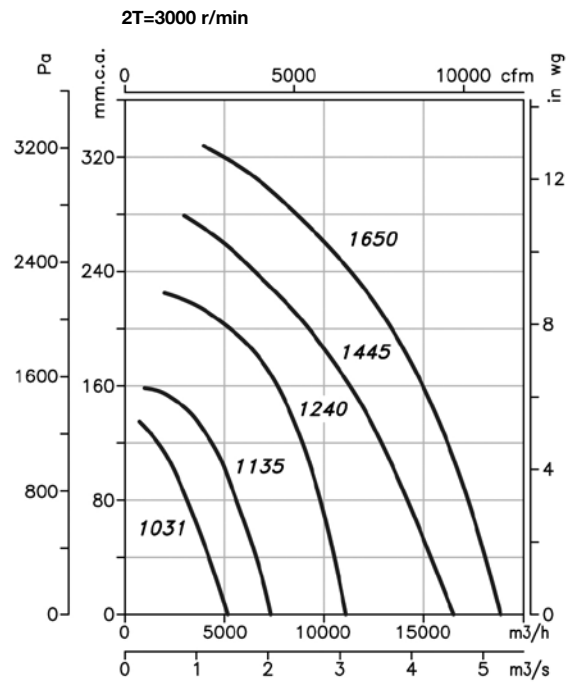
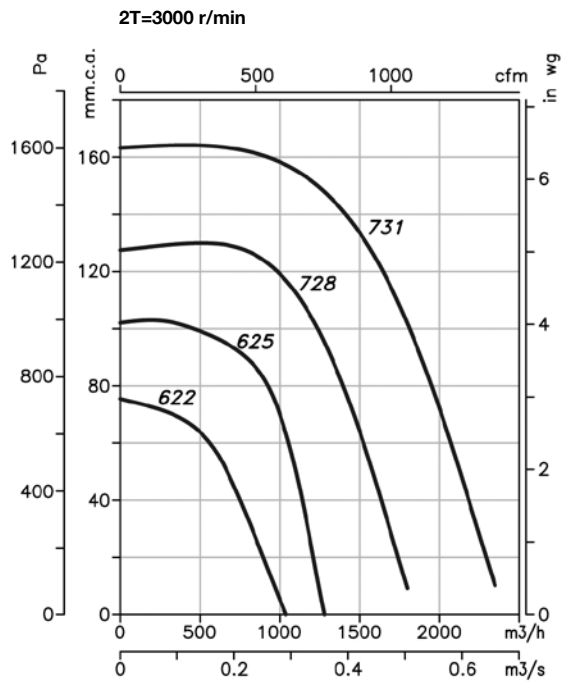

Characteristic Curves

Q = Airflow in m³/h, m³/s and cfm.

Pe = Static pressure in mm.w.c., Pa and in wg.

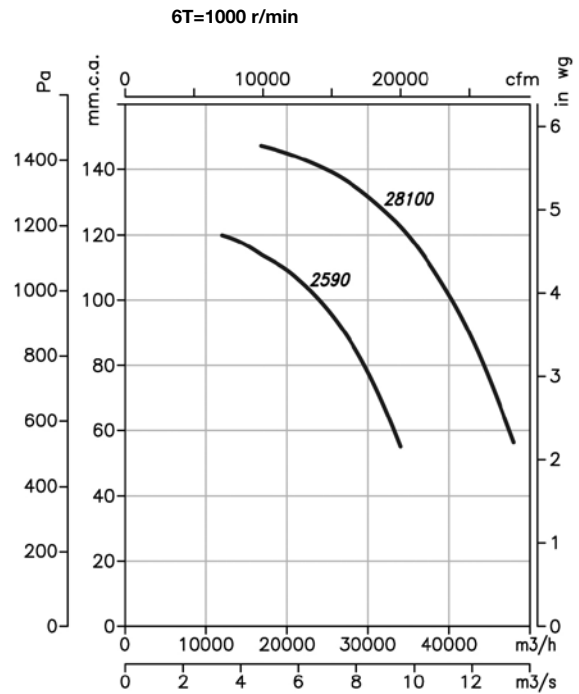
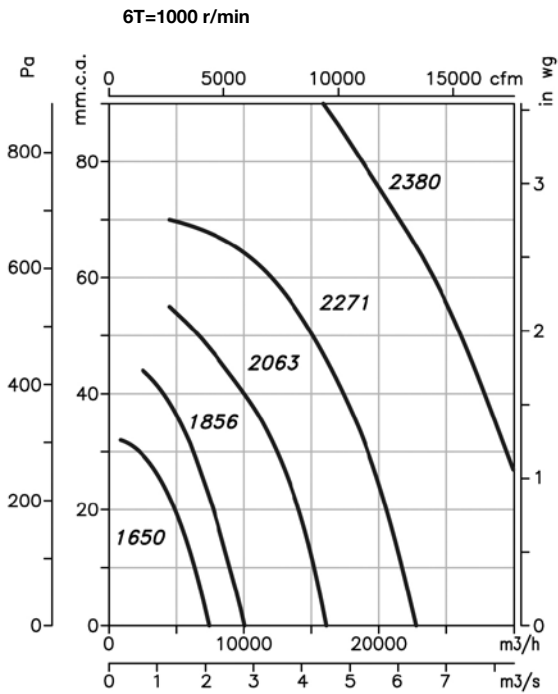
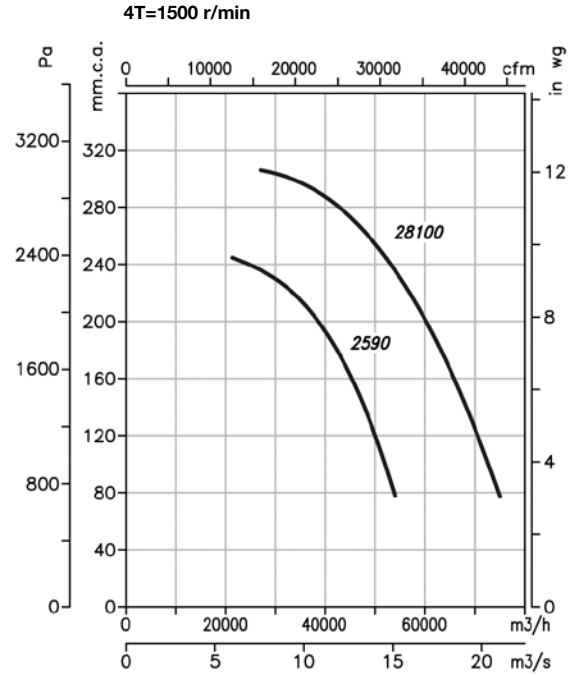
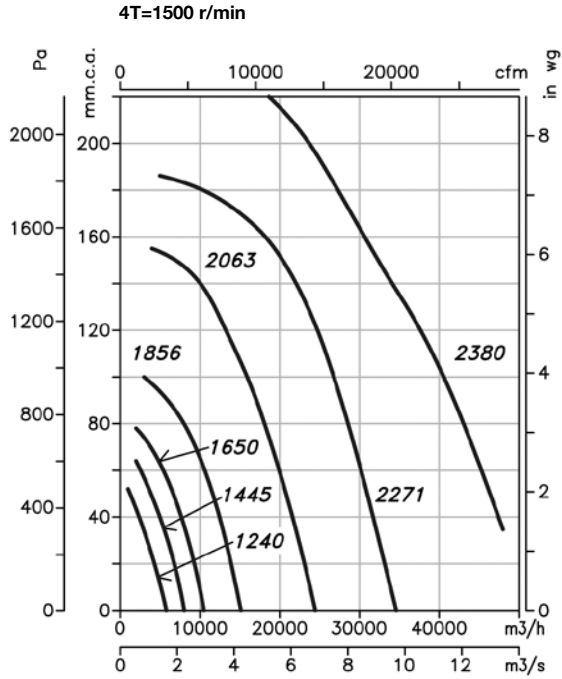

Characteristic Curves

Q = Airflow in m³/h, m³/s and cfm.

Pe = Static pressure in mm.w.c., Pa and in wg.

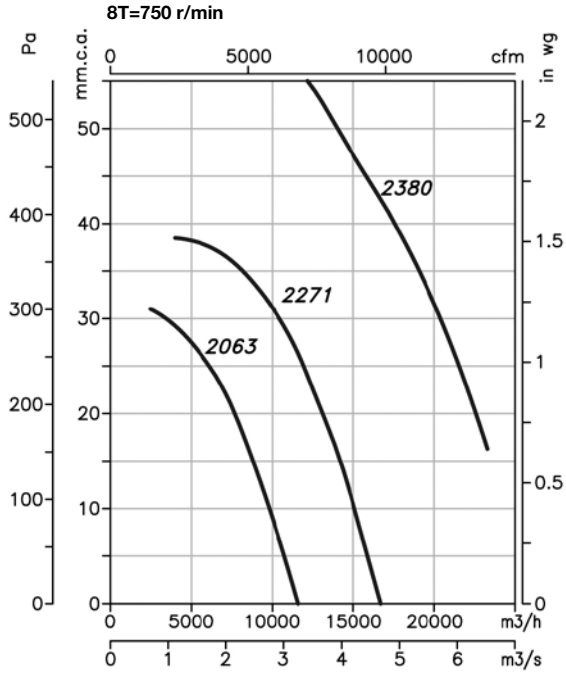

Positions

LG 270 standard supply

Models 2380, 2590 and 28100 fixed position LG 270 (other positions only on request)

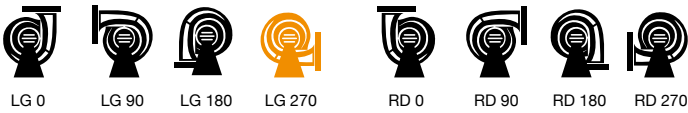

Accessories

See the accessories section.



CBP CBPC

CBP: Centrifugal, single-inlet medium-pressure fans fitted with a backward-curved impeller that includes a self-cleaning system, especially designed for painting booths

CBPC: Centrifugal, single-inlet medium-pressure fans fitted with a backward-curved impeller that includes a self-cleaning system, especially designed for painting booths, with vertical outlet



CBP



CBPC

Fan:

- Steel sheet casing
- Impeller with backward-curved blades made from sheet steel
- Inspection hatch
- CBPC: with vertical outlet

Motor:

- Motors with IE-2 efficiency, except for motors with lower powers than 0.75 kW, monophase motors or two-speed motors
- Class F motors with ball bearings, IP55 protection
- Three-phase 230/400V.-50Hz. (up to 5.5CV.)
- Max. air temperature to transport: -20°C.+ 120°C.

Finish:

- Anticorrosive finish in polyester resin, polymerised at 190°C, after alkaline degreasing and phosphate-free pre-treatment.

On request:

- Special windings for different voltages.
- ATEX certification, Category 2



High-performance and robust backward-curved impeller.

Order code



CBP: Centrifugal fans for painting booths

Impeller size

Number of motor poles
4=1400 r/min. 50 Hz

T=Three-phase

Power motor (c.v.)

CBPC: Centrifugal fans for painting booths with vertical outlet

Technical characteristics

Model	Speed (r/min)	Maximum admissible current (A)		Installed Power (kW)	Maximum Airflow (m ³ /h)	Sound pressure level dB(A)	Approx. weight	
		230V	400V				CBP	CBPC
CBP-1445-4T CBPC-1445-4T	1400	4.57	2.64	1.10	8200	73	62	75
CBP-1650-4T-2 CBPC-1650-4T-2	1400	5.97	3.45	1.50	11050	76	79	95
CBP-1650-4T-3 CBPC-1650-4T-3	1420	8.38	4.84	2.20	13500	78	92	100
CBP-1556-4T CBPC-1556-4T	1420	11.21	6.47	3.00	14000	80	122	149
CBP-1856-4T-4 CBPC-1856-4T-4	1420	11.21	6.47	3.00	16100	80	122	149
CBP-1856-4T-5.5 CBPC-1856-4T-5.5	1430	14.31	8.26	4.00	17200	82	128	155

Acoustic features

Sound power Lw(A) spectrum in dB(A) via frequency band in Hz.

Model	63	125	250	500	1000	2000	4000	8000	Model	63	125	250	500	1000	2000	4000	8000
CBP-1445	60	73	79	84	81	84	79	65	CBPC-1445	60	73	79	84	81	84	79	65
CBP-1650	66	76	84	86	85	87	78	68	CBPC-1650	66	76	84	86	85	87	78	68
CBP-1556	68	77	90	86	89	90	84	70	CBPC-1556	68	77	90	86	89	90	84	70
CBP-1856	70	79	92	88	91	92	86	72	CBPC-1856	70	79	92	88	91	92	86	72

Dimensions in mm

CBP

Boca de aspiración

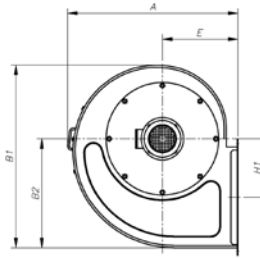
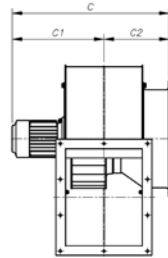
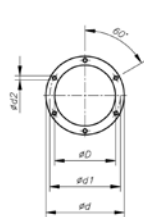

Boca de impulsión

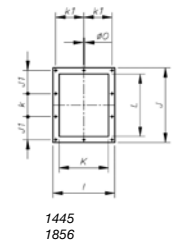
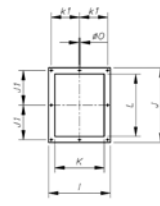

Modelo	A	B1	B2	C	C1	C2	øD	ød	ød1	ød2	E	H1	I	J	J1	K	k	k1	L	ø0
CBP-1445-4T	765	847	505	765	463	302	460	534	500	12	350	271	445	538	166	355	166	202,5	450	11
CBP-1650-4T	831	932	555	855	490	365	512	590	565	12	375	297	490	590	275	400	-	225	500	13
CBP-1556-4T	923	1041	617	890	542	348	560	634	610	348	415	328	550	660	203	450	203	250	560	13
CBP-1856-4T	923	1041	617	890	542	348	560	634	610	348	415	328	550	660	203	450	203	250	560	13

CBPC

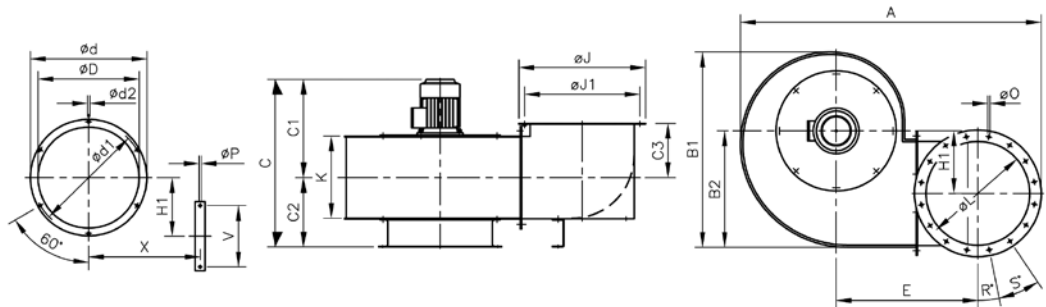

Modelo	A	B1	B2	C	C1	C2	C3	øD	ød	ød1	ød2	E	H1	øJ	øJ1	K	øL	ø0	R°	S°	øP	V	X	
CBPC-1445-4T	1307	847	505	728	426	302	236	445	530	500	12	615	271	550	500	361	450	M8	-	8x45°	11	260	510	
CBPC-1650-4T	1428	932	555	851	486	365	256	512	590	565	12	670	297	600	560	404	500	M8	15°	12x30°	11	310	567	
CBPC-1556-4T	1580	1041	617	916	568	348	296	560	634	610	12	730	328	680	629	456	560	M12	11°15'	16x22°30'	11	360	620	
CBPC-1856-4T	1580	1041	617	916	568	348	296	560	634	610	12	730	328	680	629	456	560	M12	11°15'		560	634	610	620

Characteristic Curves

Q = Airflow in m³/h, m³/s and cfm.

Pe = Static pressure in mm.w.c., Pa and in wg.

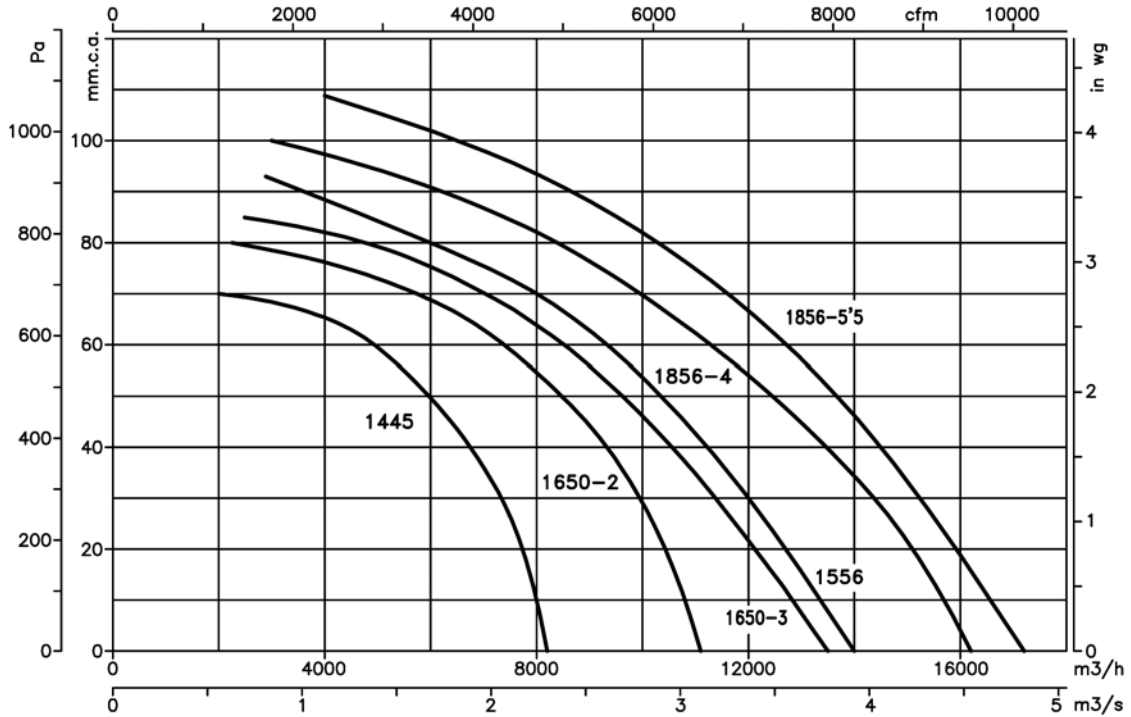

Positions

LG 270 standard supply



LG 270



RD 270

Accessories

See the accessories section.



INT

C2V

RM

AR

RFT

AET

RPA

BIC

CAS CAS-S

CAS: Centrifugal single-inlet, high-pressure fans with casing and sheet steel impeller

CAS-S: Centrifugal single-inlet, high-pressure fans with casing and sheet steel impeller



Fan:

- Steel sheet casing
- Impeller with backward-facing blades made from galvanised sheet steel, except models 242-248-254-260-640-645-650 which have a cast aluminium impeller.
- CAS-S: Hexagonal noise reducer mounted on the fan inlet. Its design allows the fan inlet airflow to be adjusted

Motor:

- Motors with IE-2 efficiency, except for motors with lower powers than 0.75 kW, monophase motors or two-speed motors
- Class F motors with ball bearings, IP55 protection
- Three-phase 230/400V.-50Hz. (up to 5.5CV) and 400/690V.-50Hz. (power over 5.5CV)
- Max. air temperature to transport: -20°C.+ 120°C.

Finish:

- Anticorrosive finish in polyester resin, polymerised at 190°C, after alkaline degreasing and phosphate-free pre-treatment.

On request:

- Special windings for different voltages
- Fan designed to transport air up to 250°C
- Stainless steel fans
- ATEX certification, Category 2



Robust motor bedplate

Order code

CAS — 460 — 2T — 7,5

CAS: Centrifugal single-inlet, high-pressure fans

Impeller size

Number of motor poles
2=2900 r/min. 50 Hz

T=Three-phase

Power motor (c.v.)

CAS-S: Centrifugal single-inlet, high-pressure fans fitted with noise reducer

Technical characteristics

Model	Speed (r/min)	Maximum admissible current (A)			Installed Power (kW)	Maximum Airflow (m³/h)	Sound pressure level CAS CAS-S		Approx. weight CAS CAS-S	
		230V	400V	690V			dB(A)		(Kg)	
CAS-242-2T-0.33	2830	1.39	0.80		0.25	450	73	67	30.0	33.0
CAS-242-2T-0.5	2740	1.92	1.11		0.37	650	73	67	31.0	34.0
CAS-248-2T-0.75	2800	2.42	1.40		0.55	420	74	68	43.5	46.5
CAS-248-2T-1	2855	3.00	1.73		0.75	500	75	69	45.0	48.0
CAS-248-2T-1.5	2845	4.16	2.40		1.10	990	76	70	46.5	49.5
CAS-254-2T-1.5	2845	4.16	2.40		1.10	600	76	70	56.5	59.5
CAS-254-2T-2	2860	5.63	3.25		1.50	800	78	72	61.5	64.5
CAS-254-2T-3	2880	7.97	4.60		2.20	1300	80	73	63.0	66.0
CAS-260-2T-2	2860	5.63	3.25		1.50	500	77	71	75.0	80.0
CAS-260-2T-3	2880	7.97	4.60		2.20	900	79	72	78.0	83.0
CAS-463-2T-5.5	2900	13.34	7.70		4.00	1150	82	75	88.5	93.5
CAS-463-2T-7.5	2855		10.50	6.10	5.50	2000	83	76	95.5	100.5
CAS-467-2T-7.5	2855		10.50	6.10	5.50	1550	84	77	117.5	122.5
CAS-467-2T-10	2855		13.90	8.00	7.50	2600	85	78	122.5	127.5
CAS-571-2T-10	2855		13.90	8.00	7.50	2000	86	78	144.0	149.0
CAS-571-2T-15	2930		20.00	11.50	11.00	3450	87	79	175.0	180.0
CAS-640-2T-2	2860	5.63	3.25		1.50	2600	77	71	51.5	56.5

Technical characteristics

Model	Speed (r/min)	Maximum admissible current (A)			Installed Power (kW)	Maximum Airflow (m³/h)	Sound pressure level CAS		Approx. weight CAS-S	
		230V	400V	690V			CAS	CAS-S	CAS	CAS-S
CAS-645-2T-3	2880	7.97	4.60		2.20	2000	76	70	62.5	70.5
CAS-645-2T-4	2895	10.57	6.10		3.00	3000	81	74	69.5	77.5
CAS-650-2T-5.5	2900	13.34	7.70		4.00	3500	81	74	89.0	97.0
CAS-650-2T-7.5	2855		10.50	6.10	5.50	4750	83	76	96.0	104.0
CAS-852-2T-7.5	2855		10.50	6.10	5.50	3500	81	74	96.0	104.0
CAS-852-2T-10	2855		13.90	8.00	7.50	5500	85	78	101.0	109.0
CAS-856-2T-15	2930		20.00	11.50	11.00	7500	85	78	157.5	167.5
CAS-863-2T-15	2930		20.00	11.50	11.00	4000	84	77	168.0	178.0
CAS-863-2T-20	2920		26.50	15.30	15.00	7000	86	78	179.0	189.0
CAS-971-2T-25	2920		32.00	18.50	18.50	5800	87	79	299.0	309.0
CAS-971-2T-30	2930		39.00	22.50	22.00	8100	88	80	324.0	334.0
CAS-971-2T-40	2955		53.00	30.60	30.00	12000	89	81	380.0	390.0
CAS-1250-2T-15/A	2930		20.00	11.50	11.00	12000	84	77	220.0	230.0
CAS-1456-2T-25/A	2920		32.00	18.50	18.50	18000	87	79	286.0	299.0
CAS-1663-2T-50/A	2950		64.00	37.00	37.00	25000	92	84	425.0	438.0
CAS-1671-2T-60/A	2940		80.00	46.20	45.00	27000	93	85	575.0	590.0
CAS-2071-2T-100/A	2970		127.00	73.30	75.00	33600	95	86	750.0	770.0
CAS-2080-2T-125/A	2970		152.00	87.80	90.00	42600	96	87	820.0	840.0
CAS-680-2T-12.5	2825		16.60	9.60	9.20	1320	86	78	160.0	165.0
CAS-790-2T-20	2920		26.50	15.30	15.00	2100	88	80	245.0	250.0
CAS-980-2T-30	2930		39.00	22.50	22.00	4800	87	79	340.0	355.0
CAS-990-2T-50	2950		64.00	37.00	37.00	6000	90	82	485.0	500.0
CAS-1080-2T-40	2955		53.00	30.60	30.00	5400	88	80	420.0	435.0
CAS-1090-2T-60	2960		79.00	45.60	45.00	6000	91	83	530.0	545.0

Acoustic features

Sound power Lw(A) spectrum in dB(A) via frequency band in Hz.

Model	63	125	250	500	1000	2000	4000	8000	Model	63	125	250	500	1000	2000	4000	8000
CAS									852-7.5	68	72	82	88	92	92	89	84
242	50	61	67	76	83	82	79	72	852-10	68	76	86	93	96	96	92	84
248-0.75	51	62	68	77	84	83	80	73	856	63	76	90	96	96	94	90	84
248-1	52	63	69	78	85	84	81	74	863-15	67	81	87	96	96	95	92	87
248-1.5	53	64	70	79	86	85	82	75	863-20	69	81	92	99	98	95	93	87
254-1.5	55	66	71	81	88	87	84	77	971-25	67	81	90	102	98	96	93	89
254-2	57	68	73	83	90	89	86	79	971-30	68	82	91	103	99	97	94	90
254-3	56	68	76	85	90	92	89	82	971-40	68	83	97	102	102	99	95	88
260-2	53	69	69	83	88	88	85	78	1250	75	88	97	94	91	86	82	73
260-3	55	71	71	85	90	90	87	80	1456	80	93	102	99	96	90	87	78
463-5.5	57	69	82	91	93	93	89	80	1663	65	74	80	95	108	100	97	93
463-7.5	58	70	83	92	94	94	90	81	1671	64	73	79	94	108	100	97	93
467-7.5	69	74	83	95	95	97	93	85	2071	66	75	81	96	110	102	99	95
467-10	70	75	84	96	96	98	94	86	2080	67	76	82	97	111	103	100	96
571-10	64	76	86	96	99	99	94	86	680	70	74	85	96	102	93	86	80
571-15	65	77	87	97	100	100	95	87	790	73	77	88	99	105	96	89	83
640	56	67	75	82	88	84	83	76	980	61	70	76	91	105	97	94	90
645-3	55	66	74	81	87	83	82	75	990	64	73	79	94	108	100	97	93
645-4	55	66	77	86	90	91	87	79	1080	62	71	77	92	106	98	95	91
650-5.5	59	75	84	90	93	90	85	78	1090	65	77	80	95	109	101	98	94
650-7.5	52	68	81	91	96	93	85	78									

Model	63	125	250	500	1000	2000	4000	8000	Model	63	125	250	500	1000	2000	4000	8000
CAS-S									852-7.5	61	65	75	81	85	85	82	77
242	44	55	61	70	77	76	73	66	852-10	61	69	79	86	89	89	85	77
248-0.75	45	56	62	71	78	77	74	67	856	56	69	83	89	89	87	83	77
248-1	46	57	63	72	79	78	75	68	863-15	60	74	80	89	89	88	85	80
248-1.5	47	58	64	73	80	79	76	69	863-20	61	73	84	91	90	87	85	79
254-1.5	49	60	65	75	82	81	78	71	971-25	59	73	82	94	90	88	85	81
254-2	51	62	67	77	84	83	80	73	971-30	60	74	83	95	91	89	86	82
254-3	49	61	69	78	83	85	82	75	971-40	60	75	89	94	94	91	87	80
260-2	47	63	63	77	82	82	79	72	1250	68	81	90	87	84	79	75	66
260-3	48	64	64	78	83	83	80	73	1456	72	85	94	91	88	82	79	70
463-5.5	50	62	75	84	86	86	82	73	1663	57	66	72	87	100	92	89	85
463-7.5	51	63	76	85	87	87	83	74	1671	56	65	71	86	100	92	89	85
467-7.5	62	67	76	88	88	90	86	78	2071	57	66	72	87	101	93	90	86
467-10	63	68	77	89	89	91	87	79	2080	58	67	73	88	102	94	91	87
571-10	56	68	78	88	91	91	86	78	680	62	66	77	88	94	85	78	72
571-15	57	69	79	89	92	92	87	79	790	65	69	80	91	97	88	81	75
640	50	61	69	76	82	78	77	70	980	53	62	68	83	97	89	86	82
645-3	49	60	68	75	81	77	76	69	990	56	65	71	86	100	92	89	85
645-4	48	59	70	79	83	84	80	72	1080	54	63	69	84	98	90	87	83
650-5.5	52	68	77	83	86	83	78	71	1090	57	66	72	87	101	93	90	86
650-7.5	45	61	74	84	89	86	78	71									

Dimensions in mm

CAS-242...971

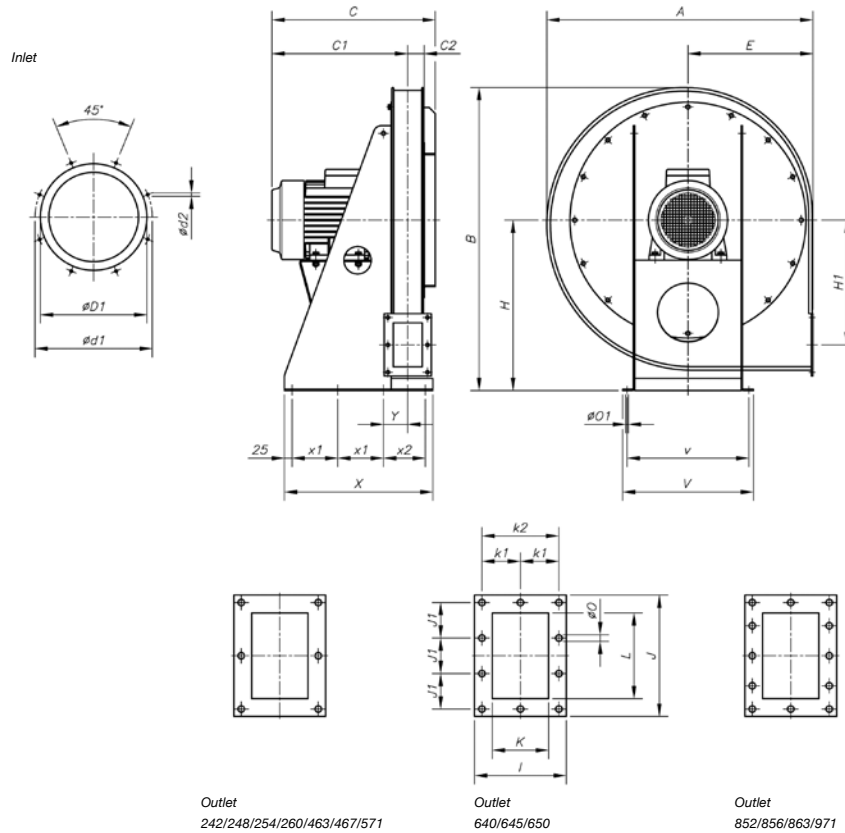

Model	A	B	C	C1	C2	$\varnothing D1$	$\varnothing d1$	$\varnothing d2$	E	H	H1	I	J	J1	K	k1	k2	L	$\varnothing O$	$\varnothing O1$	V	v	X	x1	x2	Y
CAS-242-2T-0'33	576	662	282	219	33	100	130	M8	270	375	270	120	155	65	60	-	95	95	11	12	305	275	260	75	-	61
CAS-242-2T-0'5	576	662	310	247	33	100	130	M8	270	375	270	120	155	65	60	-	95	95	11	12	305	275	260	75	-	61
CAS-248-2T-0'75	639	728	315	249	36	112	140	M8	300	410	297	126	165	70	66	-	101	105	11	12	320	290	300	90	-	64
CAS-248-2T-1'1'5	639	728	340	274	36	112	140	M8	300	410	297	126	165	70	66	-	101	105	11	12	320	290	300	90	-	64
CAS-254-2T-1'5	699	788	365	294,5	40,5	125	155	M8	330	440	322	135	175	75	75	-	110	115	11	14	340	310	330	100	-	68,5
CAS-254-2T-2	699	788	413	342,5	40,5	125	155	M8	330	440	322	135	175	75	75	-	110	115	11	14	340	310	330	100	-	68,5
CAS-254-2T-3	699	788	443	372,5	40,5	125	155	M8	330	440	322	135	175	75	75	-	110	115	11	14	340	310	330	100	-	68,5
CAS-260-2T-2'3	782	875	419	343,5	47,5	150	175	M8	370	485	362	145	185	80	85	-	120	125	11	14	380	350	370	115	-	73,5
CAS-463-2T-5'5	782	875	459	383,5	45,5	200	240	M8	370	485	362	145	185	80	85	-	120	125	11	14	380	350	370	115	-	73,5
CAS-463-2T-7'5	782	875	517	441,5	45,5	200	240	M8	370	485	362	145	185	80	85	-	120	125	11	14	380	350	370	115	-	73,5
CAS-467-2T-7'5'10	833	945	530	442	48	224	258	M8	390	530	395	150	190	82,5	90	-	125	130	11	14	405	375	300	125	-	76
CAS-571-2T-10	873	995	536	445,5	50,5	250	275	M8	410	560	410	155	205	90	95	-	130	145	11	14	430	400	350	150	-	79,5
CAS-571-2T-15	873	995	671	580,5	50,5	250	275	M8	410	560	410	155	205	90	95	-	130	145	11	14	430	400	410	180	-	79,5
CAS-640-2T-2	639	728	446	350,5	65,5	250	275	M8	300	410	250	185	260	78	125	80	-	200	11	14	340	310	350	100	-	93,5
CAS-645-2T-3	699	788	461	358	73	250	275	M8	330	440	267,5	200	284	86	140	87,5	-	224	11	14	380	350	380	115	-	101
CAS-645-2T-4	699	788	491	388	73	250	275	M8	330	440	267,5	200	284	86	140	87,5	-	224	11	14	380	350	380	115	-	101
CAS-650-2T-5'5	782	875	534	421	83	250	275	M8	370	485	300	220	310	95	160	97,5	-	250	11	14	405	375	490	125	190	111
CAS-650-2T-7'5	782	875	572	459	83	250	275	M8	370	485	300	220	310	95	160	97,5	-	250	11	14	405	375	490	125	190	111
CAS-852-2T-7'5'10	833	945	603	470	94,5	380	310	M8	390	530	320	240	340	78	180	107,5	-	280	11	14	430	400	540	150	190	122
CAS-856-2T-15	833	945	708	575	93	355	395	M8	390	530	320	240	340	78	180	107,5	-	280	11	14	430	400	600	180	190	122
CAS-863-2T-15'20	873	995	728	585	103	355	410	M8	410	560	325	260	375	87,5	200	117,5	-	315	11	14	430	400	620	180	210	132
CAS-971-2T-25	1012	1170	759	598	116	400	450	M10	460	670	420	294	425	100	224	132	-	355	11	14	550	510	500	150	150	145
CAS-971-2T-30	1012	1170	881	720	116	400	450	M10	460	670	420	294	425	100	224	132	-	355	11	14	550	510	500	150	150	145
CAS-971-2T-40	1012	1170	948	787	116	400	450	M10	460	670	420	294	425	100	224	132	-	355	11	14	550	510	500	150	150	145

Dimensions in mm

CAS-1250...2080

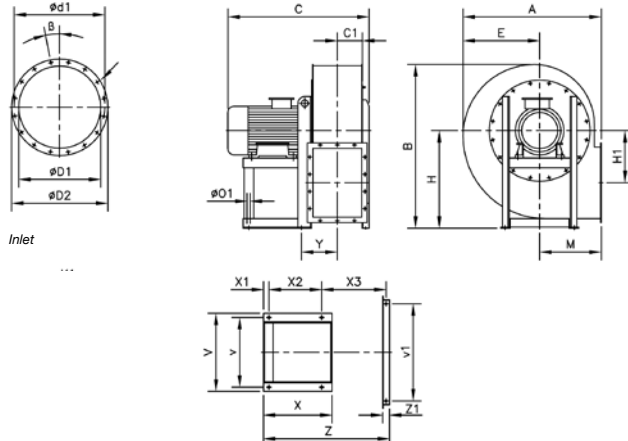

Outlet
CAS-1250-2T-15/A
CAS-1456-2T-25/A
CAS-1663-2T-50/A

Outlet
CAS-1671-2T-60/A
CAS-2071-2T-100/A
CAS-2080-2T-125/A

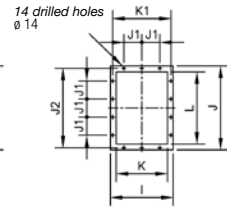
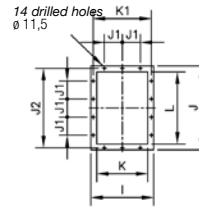

Model	A	B	C	C1	øD1	øD2	ød1	x ø	B	E	H	H1	I	J	J1	J2	K	K1	L	M	øO1	V	v	v1	X	X1	X2	X3	Y	Z	Z1
CAS-1250-2T-15/A	865	1055	885	160	361	441	405	8x11,5	22°30'	510	630	365	360	480	125	448	280	332	400	355	14	440	400	-	425	30	340	-	202	-	-
CAS-1456-2T-25/A	970	1185	900	163	456	535	497	12x12	15°	555	710	410	395	530	125	497	315	366	450	400	14	440	400	-	425	30	340	-	219	-	-
CAS-1663-2T-50/A	1010	1280	1035	183	568	668	629	16x11,5	11°15'	560	800	380	435	580	125	551	355	405	500	450	16	570	510	-	500	40	385	-	263	-	-
CAS-1671-2T-60/A	1130	1340	1160	206	638	738	698	16x13	11°15'	630	800	430	500	660	160	629	400	464	560	500	19	626	565	800	550	40	425	530	292	1025	60
CAS-2071-2T-100/A	1130	1340	1290	206	638	738	698	16x13	11°15'	630	800	430	500	660	160	629	400	464	560	500	21	760	680	800	700	50	550	545	307	1125	60
CAS-2080-2T-125/A	1270	1505	1345	231	718	818	775	16x13	11°15'	710	900	486	550	730	160	698	450	513	630	560	24	760	680	900	700	50	550	595	333	1225	60

CAS-680...1090

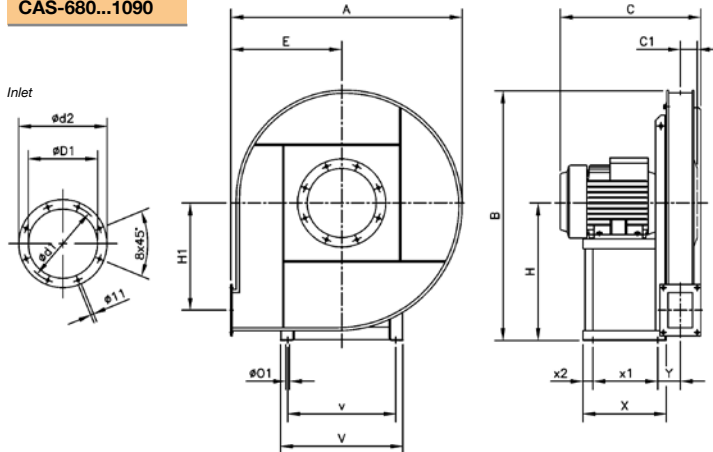

Outlet
CAS-680/790

Outlet
CAS-980...1090

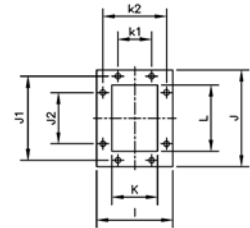
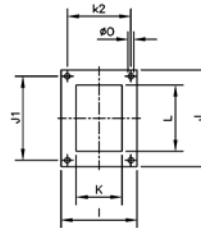

Model	A	B	C	C1	øD1	ød1	ød2	E	H	H1	I	J	J1	J2	K	k1	k2	L	ø0	øO1	V	v	X	x1	x2	Y
CAS-680-2T-12'5	925	995	550	50	165	200	235	450	530	430	131	160	125	-	71	-	100	100	9	12	392	360	320	250	25	87
CAS-790-2T-20	1100	1180	650	58	185	219	255	530	630	520	140	172	140	-	80	-	112	112	9	14	440	400	425	340	30	103
CAS-980-2T-30	1120	1250	725	90	255	292	325	530	710	530	210	270	241	112	140	112	182	200	11,5	14	440	400	425	340	35	145
CAS-990-2T-50	1250	1400	900	100	286	332	366	600	800	600	230	294	265	112	160	112	200	224	11,5	16	570	510	500	385	40	165
CAS-1080-2T-40	1120	1250	850	90	255	392	325	530	710	530	210	270	241	112	140	112	182	200	11,5	16	570	510	500	385	40	155
CAS-1090-2T-60	1250	1400	930	100	286	332	366	600	800	600	230	294	265	112	160	112	200	224	11,5	16	626	565	550	425	40	175

CAS-S

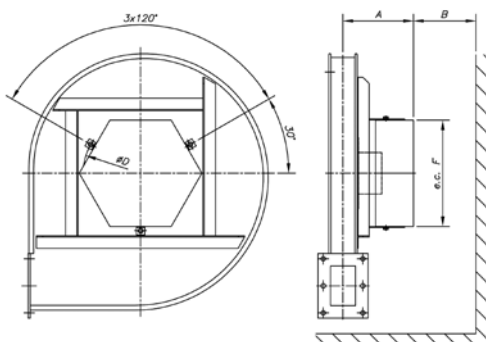

Model	A	B	øD	F
CAS-S-242	155	150	276	255
CAS-S-248	158	150	276	255
CAS-S-254	162	150	276	255
CAS-S-260	249	150	371	350
CAS-S-463	247	150	371	350
CAS-S-467	249	150	371	350
CAS-S-571	251	150	371	350
CAS-S-640	267	150	371	350
CAS-S-645	275	200	581	560
CAS-S-650	295	200	661	560
CAS-S-852	305	200	661	560
CAS-S-856	304	200	683	655
CAS-S-863	314	200	758	655

Model	A	B	øD	F
CAS-S-971	327	200	759	655
CAS-S-1250/A	371	200	683	655
CAS-S-1456/A	230	200	804	775
CAS-S-1663/A	234	200	804	775
CAS-S-680	251	200	371	350
CAS-S-790	259	200	371	350
CAS-S-980	290	200	581	560
CAS-S-990	300	200	581	560
CAS-S-1080	290	200	581	560
CAS-S-1090	300	200	581	560
CAS-S-1671/A	437	200	804	775
CAS-S-2071/A	437	200	804	775
CAS-S-2080/A	462	200	884	855

Characteristic Curves

Q = Airflow in m³/h, m³/s and cfm.

Pe = Static pressure in mm.w.c., Pa and in wg.

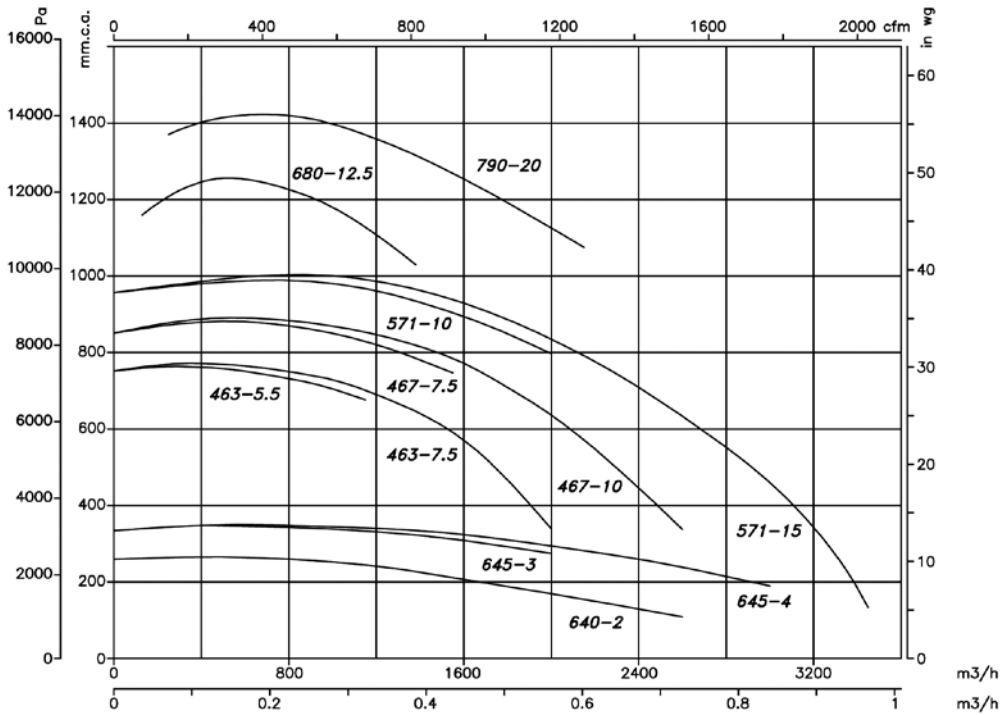
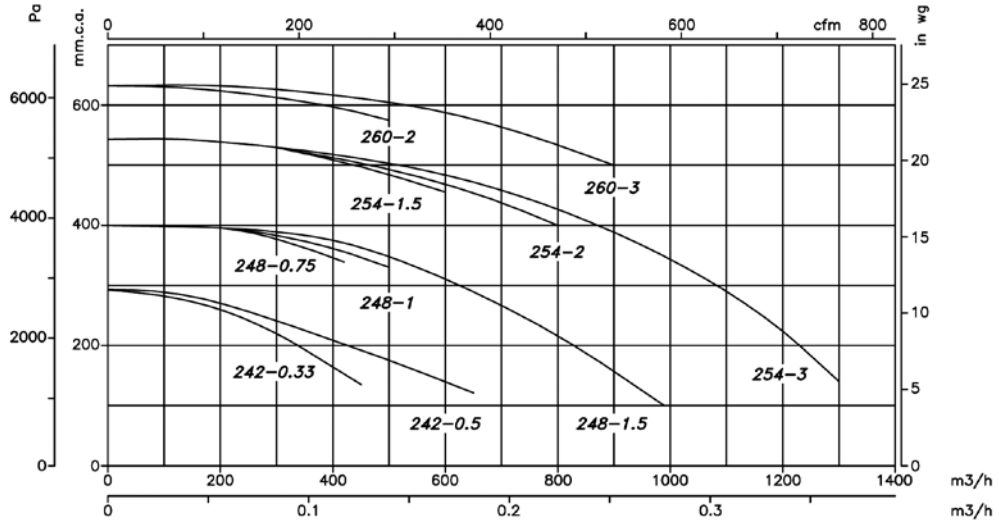

Characteristic Curves

Q = Airflow in m³/h, m³/s and cfm.

Pe = Static pressure in mm.w.c., Pa and in wg.

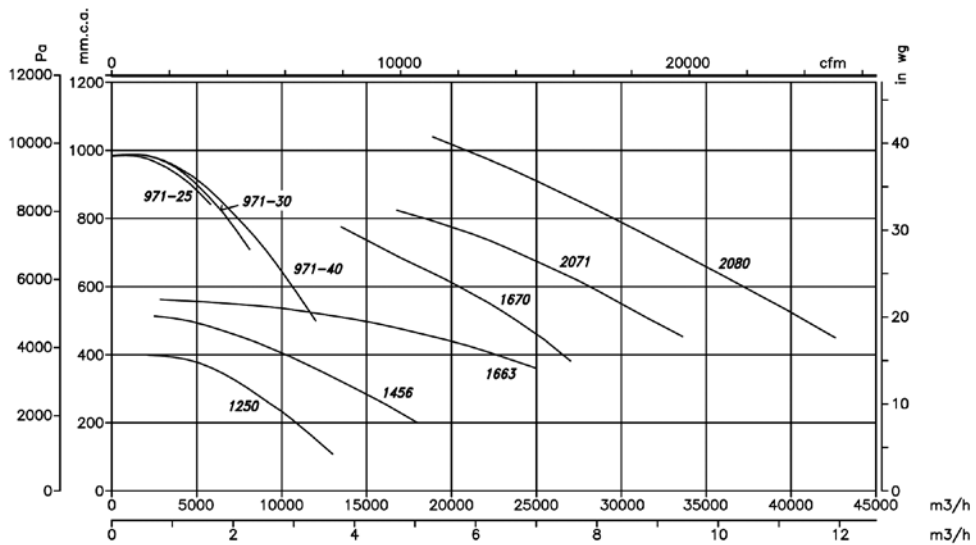
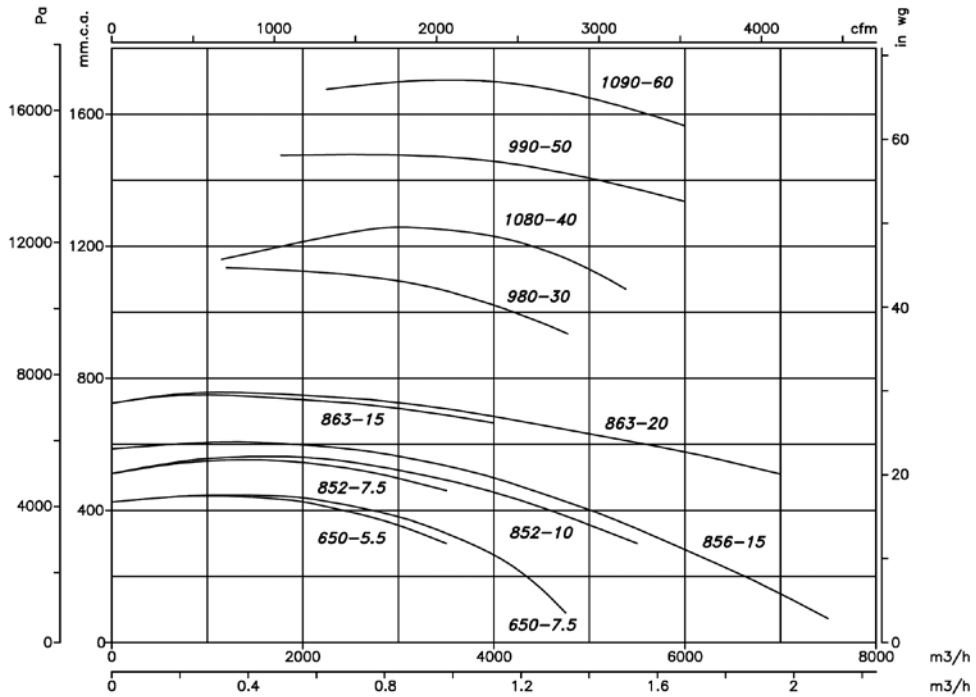

Positions

LG 270 standard supply
 LG 180 positions on request and with special fixing measurements.



Supplied on request
 RD 180 positions with special fixing measurements.



Accessories

See the accessories section.



CA

Centrifugal single-inlet, high-pressure fans with casing and impeller made from cast aluminium



- Fan:
- Casing made from cast aluminium
 - Impeller made from cast aluminium

- Motor:
- Motors with IE-2 efficiency, except for motors with lower powers than 0.75 kW, monophase motors or two-speed motors
 - Class F motors with ball bearings, IP55 protection
 - Three-phase 230/400V.-50Hz. (up to 5.5CV.) and 400/690V.-50Hz. (power over 5.5CV.)
 - Max. air temperature to transport: -20°C.+ 120°C.

- Finish:
- Anticorrosive finish in polyester resin, polymerised at 190°C, after alkaline degreasing and phosphate-free pre-treatment.

- On request:
- Special windings for different voltages
 - Fan designed to transport air up to 250°C
 - ATEX certification, Category 2

Built from thick aluminium to reduce noise and vibrations

Order code

CA — 148 — 2T — 0.75

CA: Centrifugal single-inlet, high-pressure fans with casing and impeller made from cast aluminium

Impeller size

Number of motor poles
2=2900 r/min. 50 Hz

T=Three-phase

Power motor (c.v.)

Technical characteristics

Model	Speed (r/min)	Maximum admissible current (A)			Installed Power (kW)	Maximum Airflow (m³/h)	Sound pressure level dB(A)	Approx. weight (Kg)
		230V	400V	690V				
CA-234-2T	2870	1.73	1.00		0.37	280	72	10.2
CA-234-2M	2870	2.95			0.37	280	72	10.2
CA-142-2T-0.33	2735	1.39	0.80		0.25	460	73	22.5
CA-142-2T-0.5	2810	1.92	1.11		0.37	660	73	22.5
CA-148-2T-0.75	2830	2.42	1.40		0.55	420	74	28.0
CA-148-2T-1	2840	3.00	1.73		0.75	500	75	30.0
CA-148-2T-1.5	2850	4.16	2.40		1.10	990	76	32.0
CA-154-2T-1.5	2830	4.16	2.40		1.10	600	78	46.0
CA-154-2T-2	2860	5.63	3.25		1.50	800	79	48.5
CA-154-2T-3	2875	7.97	4.60		2.20	1280	80	50.5
CA-160-2T-2	2850	5.63	3.25		1.50	500	83	57.0
CA-160-2T-3	2860	7.97	4.60		2.20	900	84	58.0
CA-166-2T-3	2870	7.97	4.60		2.20	500	84	67.0
CA-166-2T-4	2870	10.57	6.10		3.00	950	85	73.0
CA-166-2T-5.5	2860	13.34	7.70		4.00	1600	86	76.0
CA-172-2T-5.5	2880	13.34	7.70		4.00	1100	87	90.0
CA-172-2T-7.5	2880		11.10	6.40	5.50	1710	88	112.0
CA-172-2T-10	2930		13.90	8.00	7.50	2300	89	124.0

Acoustic features

Sound power Lw(A) spectrum in dB(A) via frequency band in Hz.

Model	63	125	250	500	1000	2000	4000	8000	Model	63	125	250	500	1000	2000	4000	8000
234	38	51	65	72	80	79	73	64	160-2	54	67	81	88	96	94	88	80
142	39	52	66	73	81	80	74	65	160-3	55	68	82	89	97	95	89	81
148-0,75	43	56	70	77	85	83	77	69	166-3	55	68	82	89	97	95	89	81
148-1	44	57	71	78	86	84	78	70	166-4	56	69	83	90	98	96	90	82
148-1,5	45	58	72	79	87	85	79	71	166-5,5	57	70	84	91	99	97	91	83
154-1,5	47	60	74	81	89	87	81	73	172-5,5	59	72	86	93	101	100	94	85
154-2	48	61	75	82	90	88	82	74	172-7,5	60	73	87	94	102	101	95	86
154-3	49	62	76	83	91	89	83	75	172-10	61	74	88	95	103	102	96	87

Dimensions in mm

CA-234

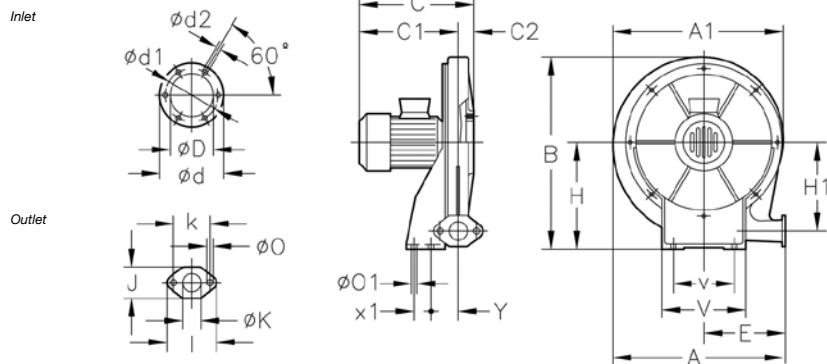

Model	A	A1	B	C	C1	C2	øD	ød	ød1	ød2	E	H	H1	I	J	øK	k	øO	øO1	V	v	x1	Y
CA-234-2T-0.33	376	381	415	272	242.5	29.5	98	130	115	M4	175	225	187	98	63	40	72	9	9	180	120	40	94
CA-234-2M-0.33	376	381	415	272	242.5	29.5	98	130	115	M4	175	225	187	98	63	40	72	9	9	180	120	40	94

CA-142...172

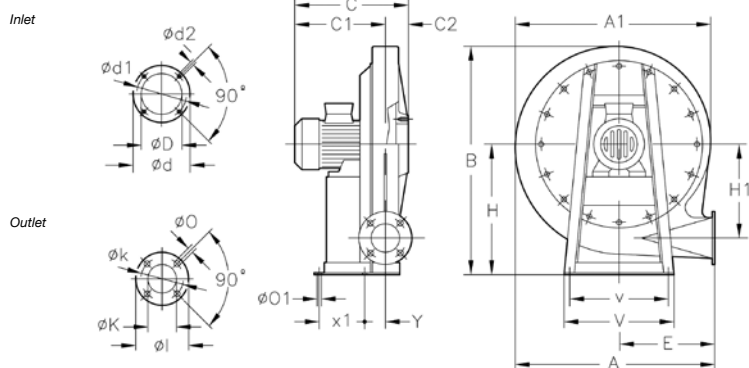

Model	A	A1	B	C	C1	C2	øD	ød	ød1	ød2	E	H	H1	I	øK	øk	øO	øO1	V	v	x1	Y
CA-142-2T-0'33	494	488	540	270	221.52	48.5	90	160	130	M8	240	301	235	120	60	90	11	12	300	270	130	51
CA-142-2T-0'5	494	488	540	290	241.5	48.5	90	160	130	M8	240	301	235	120	60	90	11	12	300	270	130	51
CA-142-2T-0'75	563	557.5	639	308.5	251.5	57	100	170	140	M8	270	360	269.5	150	73	110	11	12	330	290	140	60
CA-148-2T-1	563	557.5	639	324.5	267.5	57	100	170	140	M8	270	360	269.5	150	73	110	11	12	330	290	140	60
CA-148-2T-1'5	563	557.5	639	324.5	267.5	57	100	170	140	M8	270	360	269.5	150	73	110	11	12	330	290	140	60
CA-154-2T-1'5	630	625	708	348	268.5	79.5	115	183	155	M10	300	395	308	160	80	120	13	12	356	320	210	62
CA-154-2T-2	630	625	708	371	291.5	79.5	115	183	155	M10	300	395	308	160	80	120	13	12	356	320	210	62
CA-154-2T-3	630	625	708	396	316.5	79.5	115	183	155	M10	300	395	308	160	80	120	13	12	356	320	210	62
CA-160-2T-2	708	699	785	381	291	90	130	230	192	M10	336	440	338	160	85	120	13	12	373	322	220	62
CA-160-2T-3	708	699	785	406	316	90	130	230	192	M10	336	440	338	160	85	120	13	12	373	322	220	62
CA-166-2T-3	759	752	866	399	319.5	79.5	140	230	200	M10	364	490	372	160	85	120	13	12	450	400	245	70
CA-166-2T-4	759	752	866	423	343.5	79.5	140	230	200	M10	364	490	372	160	85	120	13	12	450	400	245	70
CA-166-2T-5'5	759	752	866	445	365.5	79.5	140	230	200	M10	364	490	372	160	85	120	13	12	450	400	265	70
CA-172-2T-5'5	818	813	923	451	371	80	148	230	200	M10	390	516	404	175	90	140	13	12	450	400	260	78
CA-172-2T-7'5	818	813	923	492	412	80	148	230	200	M10	390	516	404	175	90	140	13	12	450	400	300	78
CA-172-2T-10	818	813	923	492	412	80	148	230	200	M10	390	516	404	175	90	140	13	12	450	400	300	78

Characteristic Curves

Q = Airflow in m³/h, m³/s and cfm.

Pe= Static pressure in mm.w.c., Pa and in wg.

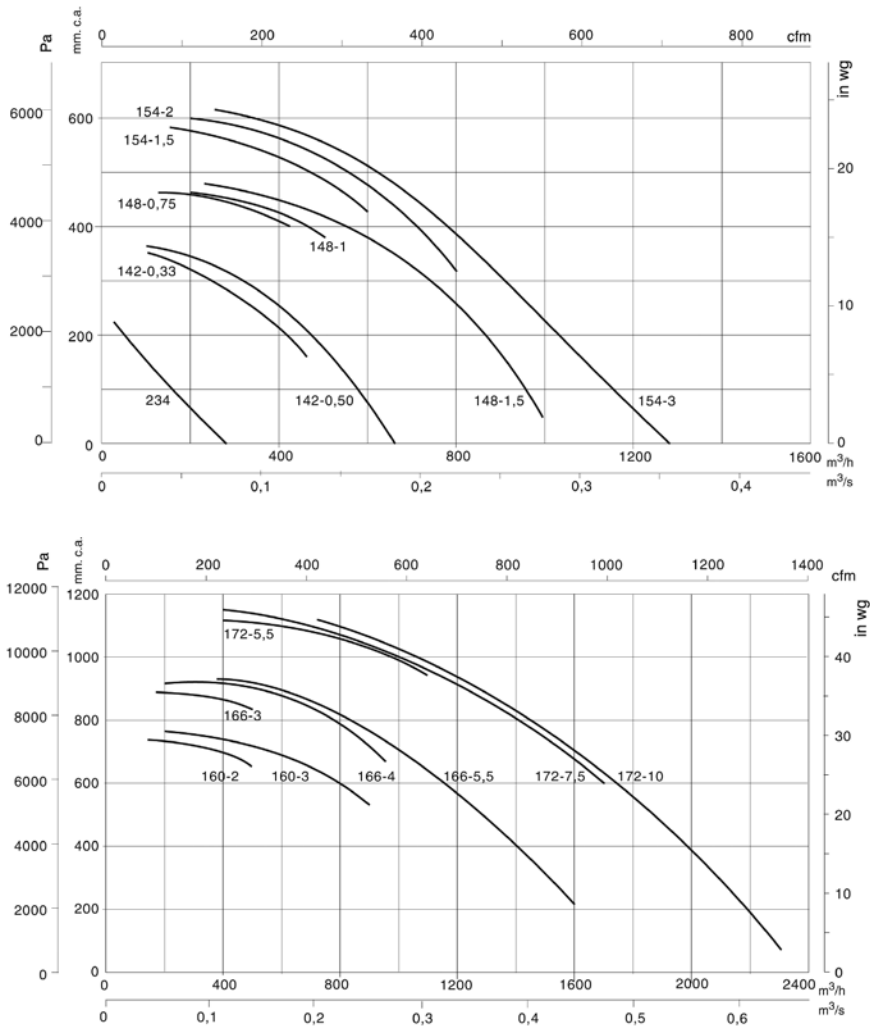

Positions

LG 270 standard supply

LG 180 positions on request and with special fixing measures.



Accessories

See the accessories section.



CAM

Centrifugal single-inlet, high-pressure fans with sheet steel casing and cast aluminium impeller



Fan:

- Steel sheet casing
- Cast aluminium impeller, models 752 and 880 in sheet steel

Motor:

- Motors with IE-2 efficiency, except for motors with lower powers than 0.75 kW, monophase motors or two-speed motors
- Class F motors with ball bearings, IP55 protection
- Three-phase 230/400V.-50Hz. (up to 5.5CV.) and 400/690V.-50Hz. (power over 5.5CV.)
- Max. air temperature to transport: -20°C.+ 120°C.

Finish:

- Anticorrosive finish in polyester resin, polymerised at 190°C, after alkaline degreasing and phosphate-free pre-treatment.

On request:

- Special windings for different voltages.
- Fan designed to transport air up to 250°C.
- Stainless steel fans
- ATEX certification, Category 2

High-performance aluminium impellers

Order code

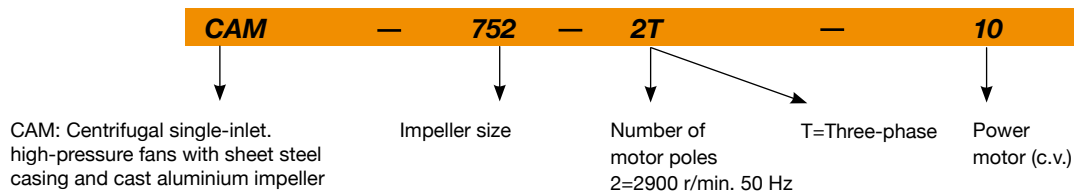

Technical characteristics

Model	Speed (r/min)	Maximum admissible current (A)			Installed Power (kW)	Maximum Airflow (m³/h)	Sound pressure level dB(A)	Approx. weight (Kg)
		230V	400V	690V				
CAM-540-2T	2890	5.63	3.25		1.50	2430	85	38.0
CAM-545-2T-3	2840	7.97	4.60		2.20	2300	86	54.0
CAM-545-2T-4	2880	10.57	6.10		3.00	3610	88	64.0
CAM-550-2T-5.5	2895	13.34	7.70		4.00	2800	90	113.0
CAM-550-2T-7.5	2925		10.50	6.10	5.50	5000	91	129.0
CAM-752-2T-7.5	2920		10.50	6.10	5.50	2950	93	138.0
CAM-752-2T-10	2910		13.90	8.00	7.50	5000	94	143.0
CAM-760-2T-10	2930		13.90	8.00	7.50	2900	95	168.0
CAM-760-2T-15	2940		20.00	11.50	11.00	5000	97	196.0
CAM-760-2T-15/E	2950		20.00	11.50	11.00	6380	98	194.0
CAM-880-2T-40	2950		53.00	30.60	30.00	10000	99	390.0

Acoustic features

Sound power Lw(A) spectrum in dB(A) via frequency band in Hz.

Model	63	125	250	500	1000	2000	4000	8000	Model	63	125	250	500	1000	2000	4000	8000
540	57	70	81	90	97	91	86	78	752-10	67	81	92	101	108	102	96	89
545-3	58	71	82	91	98	92	87	79	760-10	70	83	95	103	110	105	99	91
545-4	60	73	84	93	100	94	89	81	760-15	72	85	97	105	112	107	101	93
550-5.5	63	77	88	97	104	98	92	85	760-15/E	73	86	98	106	113	108	102	94
550-7.5	64	78	89	98	105	99	93	86	880	75	89	100	109	116	110	104	97
752-7.5	66	80	91	100	107	101	95	88									

Dimensions in mm

CAM-540...545

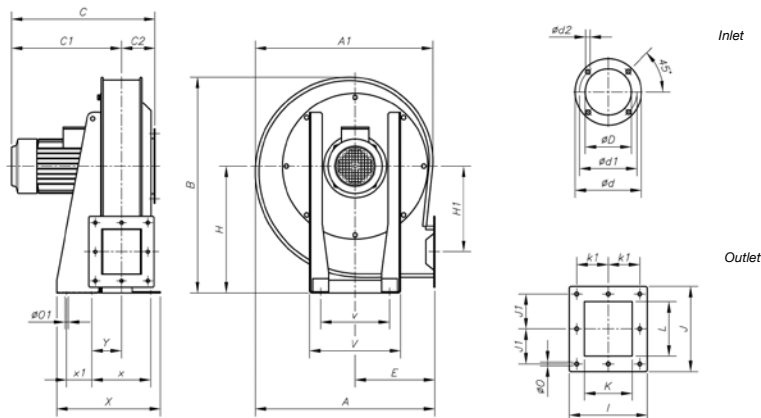

Model	A	A1	B	C	C1	C2	ØD	Ød	Ød1	Ød2	E	H	H1	I	J	J1	K	k1	L	Ø0	Ø01	V	v	X	x	x1	Y
CAM-540-2T	565	556	678	424	318	106	170	235	205	11	252	400	270	206	224	92	120	83	140	10	12	280	218	328	186	80	94
CAM-545-2T-3	650	636	768	467	351,5	115,5	165	235	205	11	290	450	310	222	255	108	135	90	170	10	12	300	238	344	202	80	102,5
CAM-545-2T-4	650	636	768	496	380,5	115,5	165	235	205	11	290	450	310	222	255	108	135	90	170	10	12	300	238	344	202	80	102,5

CAM-550...880

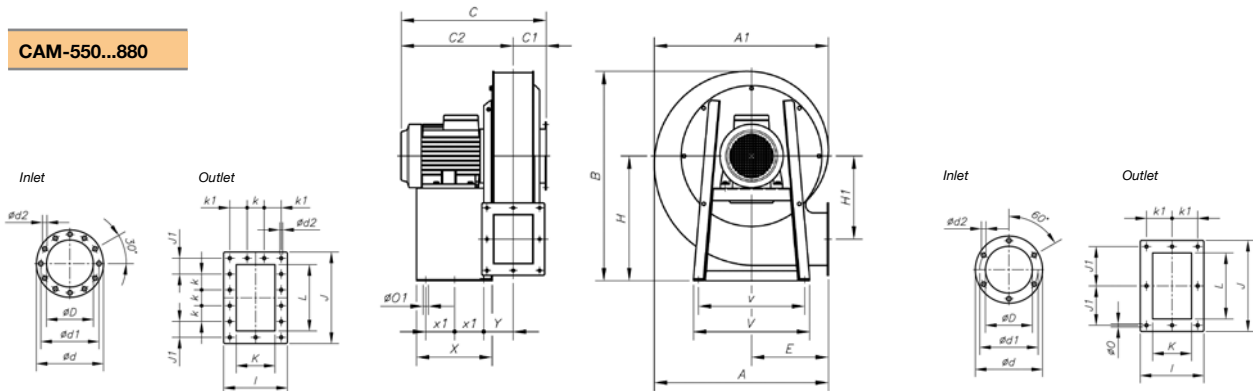

Model	A	A1	B	C	C1	C2	ØD	Ød	Ød1	Ød2	E	H	H1	I	J	J1	K	k	k1	L	Ø0	Ø01	V	v	X	x1	Y
CAM-550-2T-5/5	719	715	868	542	406	136	210	278	258	9	311	510	350	246	296	128	150	-	103	200	11	13	475	435	369	105	115,5
CAM-550-2T-7/5	719	715	868	583	447	136	210	278	258	9	311	510	350	246	296	128	150	-	103	200	11	13	475	435	390	105	115,5
CAM-752-2T-7/5	713	713	856	624	489	135	217	278	258	9	315	510	340	256	296	128	160	-	108	200	11	13	475	435	390	105	121
CAM-752-2T-10	713	713	856	624	489	135	217	278	258	9	315	510	340	256	296	128	160	-	108	200	11	13	475	435	390	105	121
CAM-760-2T-10	837,5	833,5	975	609	462	147	246	322	280	9,5	370	570	380	276	316	138	180	-	118	220	11	13	570	525	450	202,5	74,5
CAM-760-2T-15	837,5	833,5	975	715	568	147	246	322	280	9,5	370	570	380	276	316	138	180	-	118	220	11	13	570	525	450	202,5	74,5
CAM-760-2T-15/E	837,5	833,5	975	715	568	147	246	322	280	9,5	370	570	380	276	316	138	180	-	118	220	11	13	570	525	450	202,5	74,5
CAM-880-2T-40	946	941	1046	905	771	134	290	390	355	10	422	710	430	249	360	61	190	71	76	290	11	13	565	523	580	210	133

Characteristic Curves

Q = Airflow in m³/h, m³/s and cfm.

Pe = Static pressure in mm.w.c., Pa and in wg.

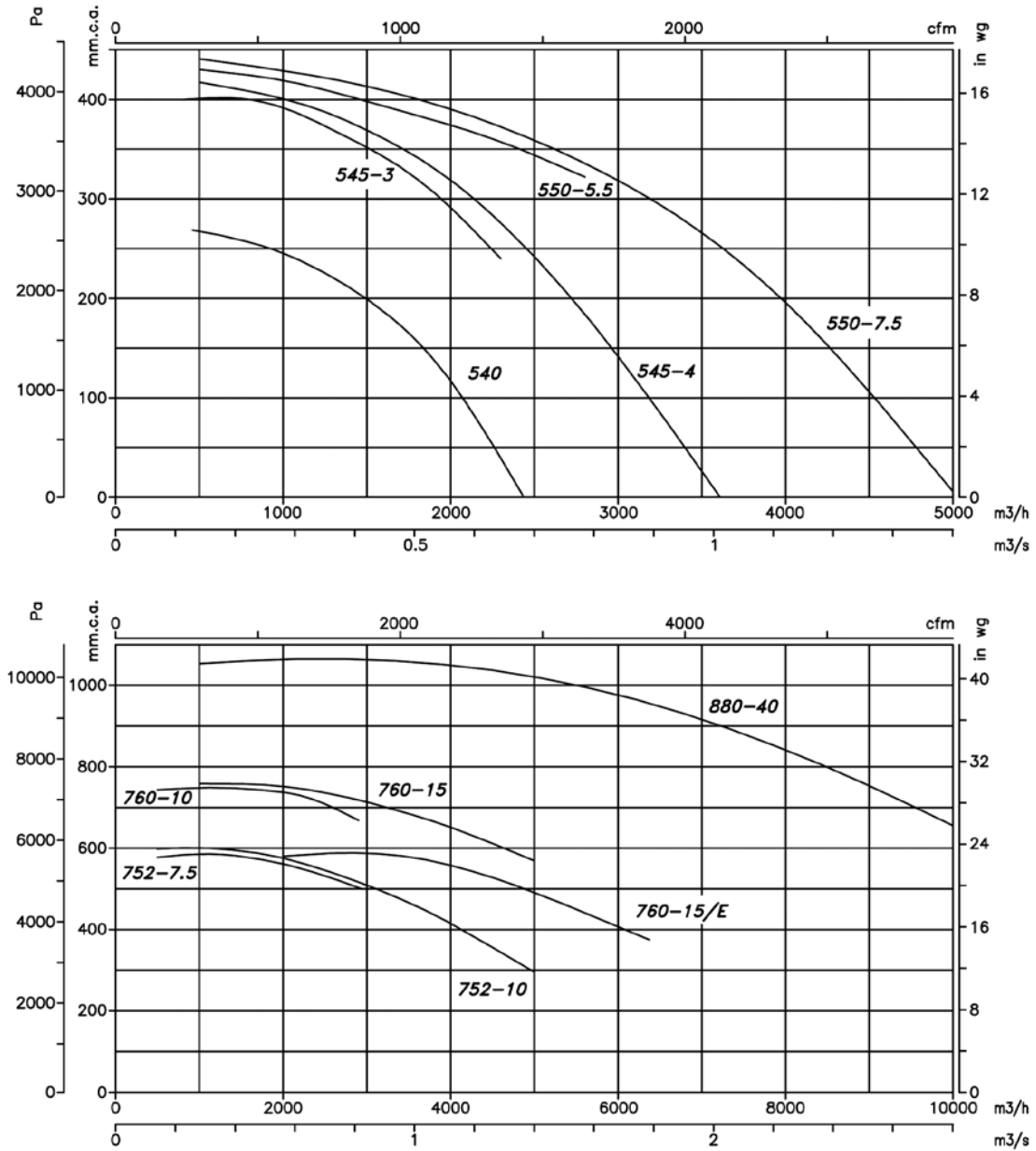

Positions

LG 270 standard supply

LG 180 positions on request and with special fixing measures.



Accessories

See the accessories section.



CAS-X

Belt-driven, high-pressure fans with electric motor, pulley and belt kit and standardised protectors in accordance with standard EN-294 and ISO-13852



Fan:

- Steel sheet casing
- Impeller with backward-curved blades made from robust sheet steel
- Motor mounted on general bedplate

Motor:

- Motors with IE-2 efficiency, except for motors with lower powers than 0.75 kW, monophase motors or two-speed motors
- Class F motors with ball bearings, IP55 protection
- Three-phase 230/400V.-50Hz. (up to 5.5CV.) and 400/690V.-50Hz. (power over 5.5CV.)
- Max. air temperature to transport: -20°C.+ 150°C.

Finish:

- Anticorrosive finish in polyester resin, polymerised at 190°C, after alkaline degreasing and phosphate-free pre-treatment.

On request:

- Special windings for different voltages
- Fan designed to transport air up to 250°C.
- Stainless steel fans
- ATEX certification, Category 2

Order code

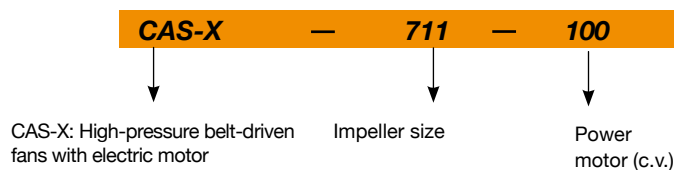

Technical characteristics

Model	Speed (r/min)	Installed Power (kW)	Maximum Airflow (m³/h)	Maximum Pressure (mm w.c.)	Weight (Kg)	Assembly type
CAS-X-711-20	1690	15	19650	290	391	B
CAS-X-711-25	1810	18.5	21050	335	430	B
CAS-X-711-30	1910	22	22200	370	453	B
CAS-X-711-40	2120	30	24650	460	503	B
CAS-X-711-50	2280	37	26500	530	620	B
CAS-X-711-60	2430	45	28250	605	652	B
CAS-X-711-75	2600	55	30200	690	730	B
CAS-X-711-100	2890	75	33600	850	1005	B
CAS-X-801-20	1380	15	23750	245	486	B
CAS-X-801-25	1480	18.5	25450	280	525	B
CAS-X-801-30	1570	22	27000	315	548	B
CAS-X-801-40	1740	30	29900	390	598	B
CAS-X-801-50	1850	37	31800	440	715	B
CAS-X-801-60	1980	45	34050	505	747	B
CAS-X-801-75	2120	55	36450	580	825	B
CAS-X-801-100	2350	75	40400	710	1100	B
CAS-X-901-30	1310	22	31450	275	623	B

Technical characteristics

Model	Speed (r/min)	Installed Power (kW)	Maximum Airflow (m ³ /h)	Maximum Pressure (mm w.c.)	Weight (Kg)	Assembly type
CAS-X-901-40	1460	30	35050	340	673	B
CAS-X-901-50	1570	37	37700	395	790	B
CAS-X-901-60	1670	45	40100	445	822	B
CAS-X-901-75	1780	55	42750	510	900	B
CAS-X-901-100	1970	75	47300	620	1175	B
CAS-X-901-125	2100	90	50400	705	1242	B
CAS-X-901-150	2240	110	53750	805	1305	B
CAS-X-1001-40	1210	30	39750	295	798	B
CAS-X-1001-50	1300	37	42700	340	915	B
CAS-X-1001-60	1390	45	45650	390	947	B
CAS-X-1001-75	1480	55	48600	440	1025	B
CAS-X-1001-100	1650	75	54200	550	1300	B
CAS-X-1001-125	1750	90	57500	620	1367	B
CAS-X-1001-150	1870	110	61450	705	1430	B
CAS-X-1001-175	1980	132	65050	790	1502	B
CAS-X-1121-50	1100	37	48050	305	1120	B
CAS-X-1121-60	1190	45	52000	360	1152	B
CAS-X-1121-75	1270	55	55500	410	1230	B
CAS-X-1121-100	1400	75	61150	495	1505	B
CAS-X-1121-125	1500	90	65500	570	1572	B
CAS-X-1121-150	1600	110	69900	645	1635	B
CAS-X-1121-175	1700	132	74250	730	1707	B
CAS-X-1121-220	1800	160	78650	820	1780	B
CAS-X-1251-60	980	45	63350	310	1412	B
CAS-X-1251-75	1050	55	67900	355	1490	B
CAS-X-1251-100	1160	75	75000	435	1765	B
CAS-X-1251-125	1230	90	79550	485	1832	B
CAS-X-1251-150	1320	110	85350	560	1895	B
CAS-X-1251-175	1400	132	90550	630	1967	B
CAS-X-1251-220	1500	160	97000	725	2040	B
CAS-X-1251-270	1600	200	103450	825	2270	B
CAS-X-1401-75	870	55	77450	300	1810	B
CAS-X-1401-100	970	75	86350	370	2085	B
CAS-X-1401-125	1030	90	91700	420	2152	B
CAS-X-1401-150	1100	110	97900	480	2215	B
CAS-X-1401-175	1170	132	104150	540	2287	B
CAS-X-1401-220	1240	160	110350	610	2360	B
CAS-X-1401-270	1340	200	119250	710	2590	B
CAS-X-1401-340	1440	250	128150	820	2680	B
CAS-X-1601-100	760	75	100100	290	2435	B
CAS-X-1601-125	810	90	106700	330	2502	B
CAS-X-1601-150	870	110	114600	385	2565	B
CAS-X-1601-175	920	132	121200	430	2637	B
CAS-X-1601-220	980	160	129100	485	2710	B
CAS-X-1601-270	1060	200	139650	570	2940	B
CAS-X-1601-340	1140	250	150200	660	3030	B
CAS-X-1601-430	1230	315	162050	765	3260	B

Dimensions in mm

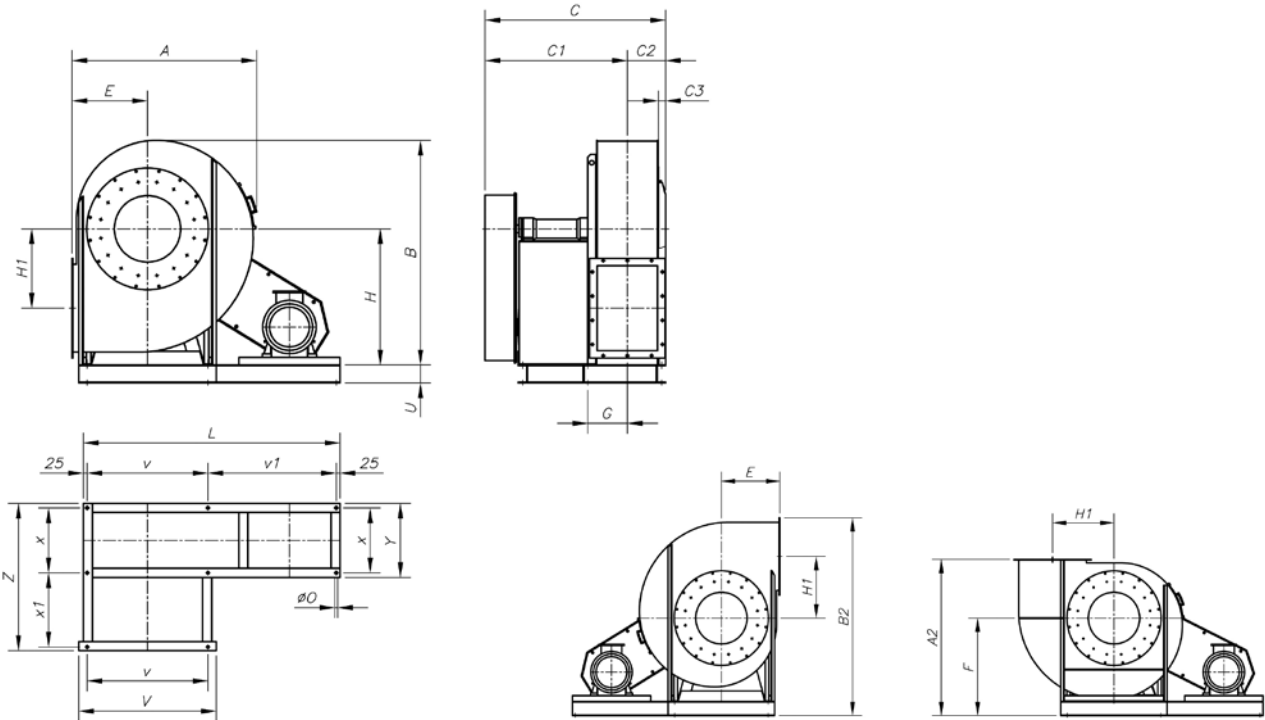

Model	A	A2	B	B2	C	C1	C2	C3	E	F	G	H	H1	L	ø0	U	V	v	v1	x	x1	Y	Z
CAS-X-711	1240	1330	1505	1705	1160	907.5	252.5	47.5	500	830	263	900	525	1700	17	120	910	800	850	430	490	490	975
CAS-X-801	1375	1500	1670	1910	1290	1001.5	288.5	57.5	560	940	293	1000	585	2050	17	140	990	870	1120	495	550	555	1105
CAS-X-901	1530	1690	1795	2115	1340	1028	312	56	630	1060	318	1060	630	2150	19	160	1090	970	1120	495	601	555	1156
CAS-X-1001	1705	1890	1980	2350	1545	1192	353	66	710	1180	349	1180	710	2250	21	180	1210	1060	1120	600	668	670	1338
CAS-X-1121	1915	2100	2220	2610	1705	1306	399	77	800	1300	394	1320	800	2390	24	180	1350	1200	1120	670	753	750	1503
CAS-X-1251	2050	2260	2490	29010	1905	1466	439	74	830	1430	454	1500	900	2520	24	180	1480	1320	1120	750	853	830	1683
CAS-X-1401	2310	2450	2745	2930	2070	1575	495	-	950	1500	494	1650	1000	2700	24	180	1660	1500	1120	800	938	880	1818
CAS-X-1601	2580	2760	3070	3265	2355	1798	557	-	1060	1700	599	1850	1120	2920	24	200	1880	1700	1120	900	1103	1000	2103

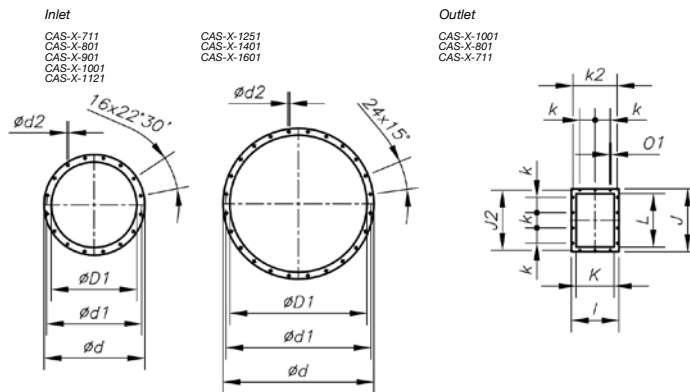

Model	øD1*	ød	ød1	ød2	I	J	J2	K	k	k2	L	O1
CAS-X-711	566	666	629	11.5	500	660	629	400	160	464	560	14
CAS-X-801	636	736	698	11.5	550	730	698	450	160	513	630	14
CAS-X-901	716	816	775	11.5	600	810	775	500	160	567	710	14
CAS-X-1001	806	906	861	14	680	920	871	560	200	639	800	14
CAS-X-1121	906	1006	958	14	750	1020	968	630	200	708	900	14
CAS-X-1251	1007	1107	1067	14	830	1120	1077	710	200	785	1000	14
CAS-X-1401	1128	1248	1200	14	940	1260	1210	800	200	881	1120	18
CAS-X-1601	1260	1380	1337	14	1040	1390	1347	900	200	978	1250	18

* Recommended nominal diameter for duct.

Characteristic Curves

Q = Airflow in m³/h, m³/s and cfm.

Pe = Static pressure in mm.w.c., Pa and in wg.

711

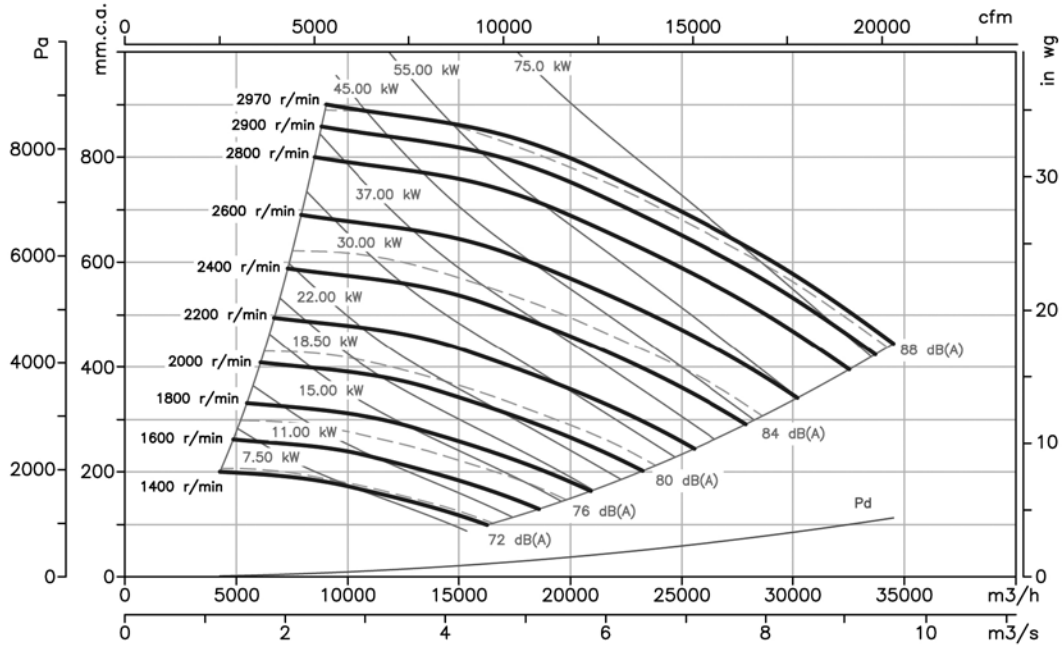

801

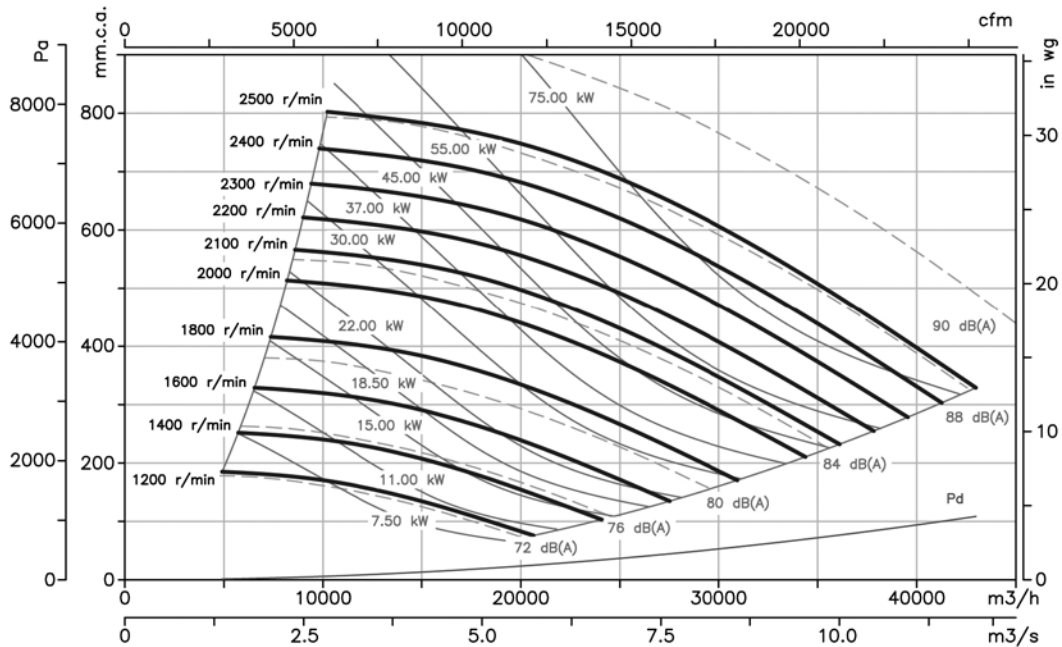

Characteristic Curves

Q = Airflow in m³/h, m³/s and cfm.

Pe= Static pressure in mm.w.c., Pa and in wg.

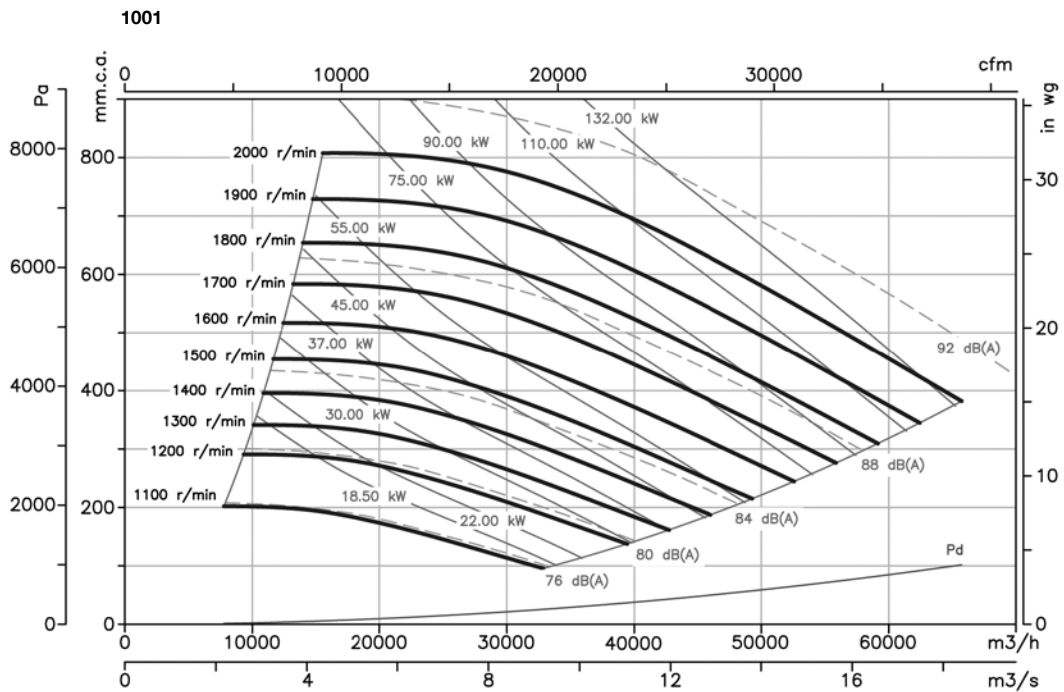
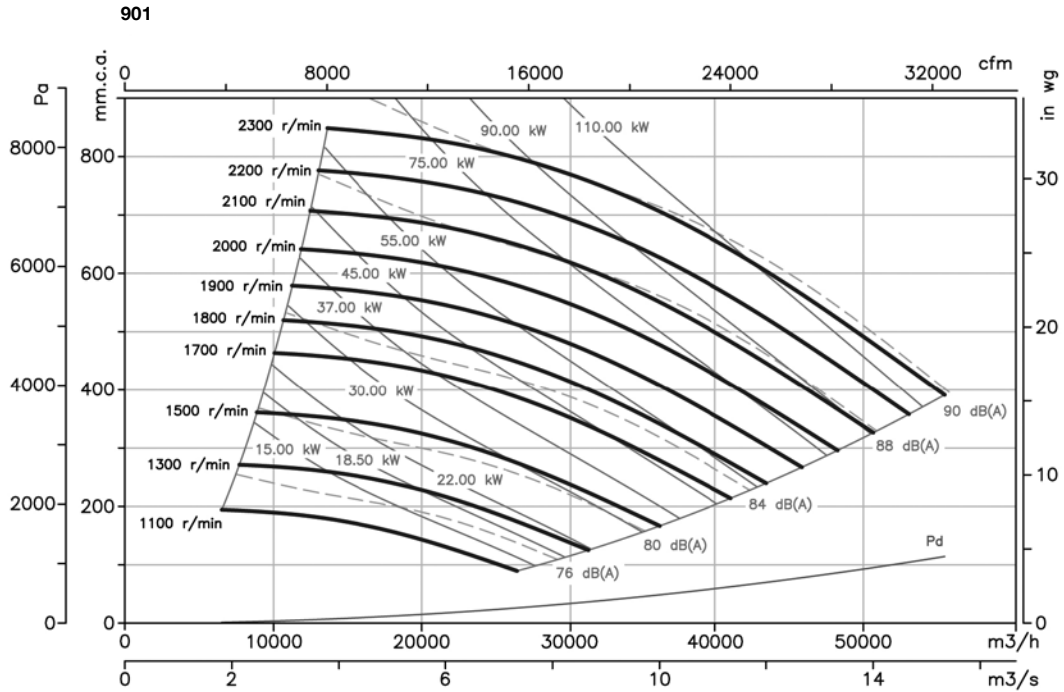

Characteristic Curves

Q = Airflow in m³/h, m³/s and cfm.

Pe = Static pressure in mm.w.c., Pa and in wg.

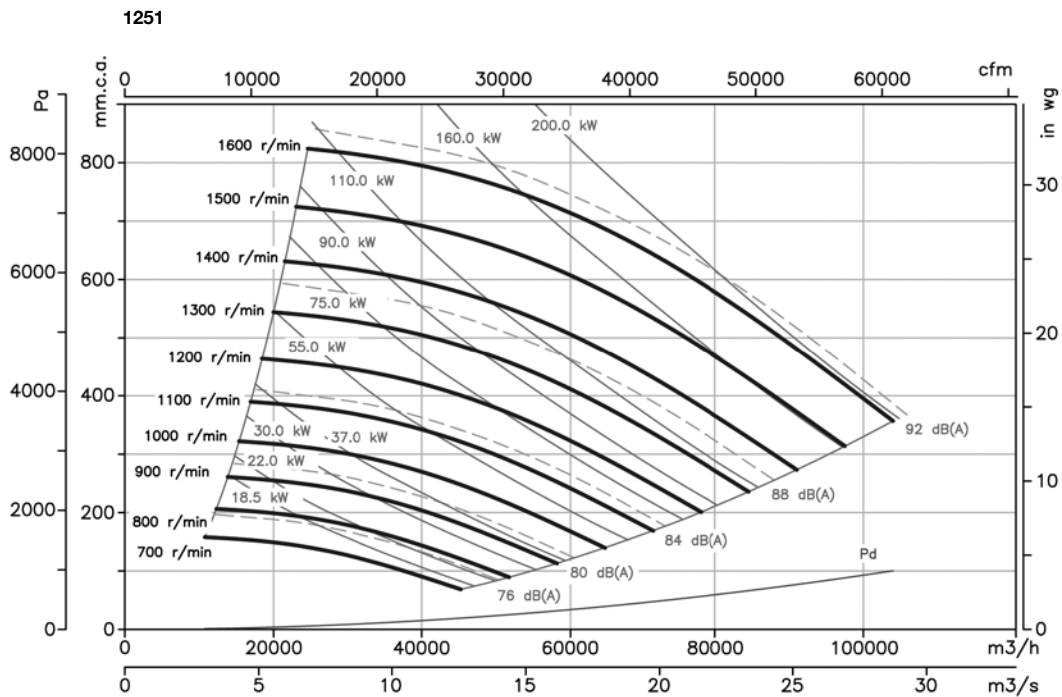
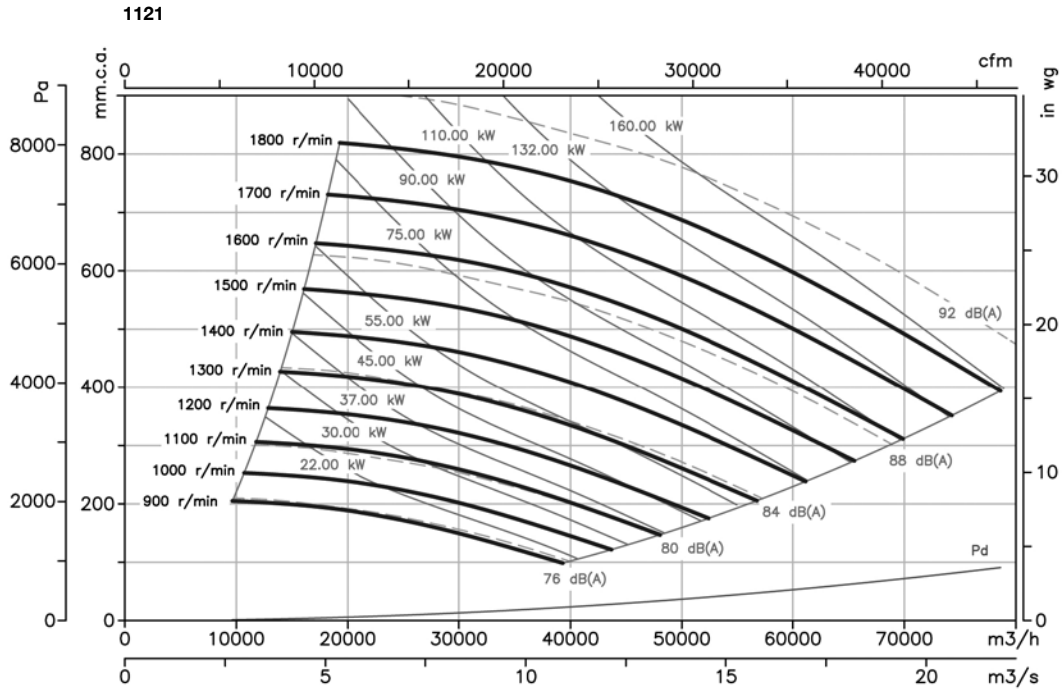

Characteristic Curves

Q = Airflow in m³/h, m³/s and cfm.

Pe= Static pressure in mm.w.c., Pa and in wg.

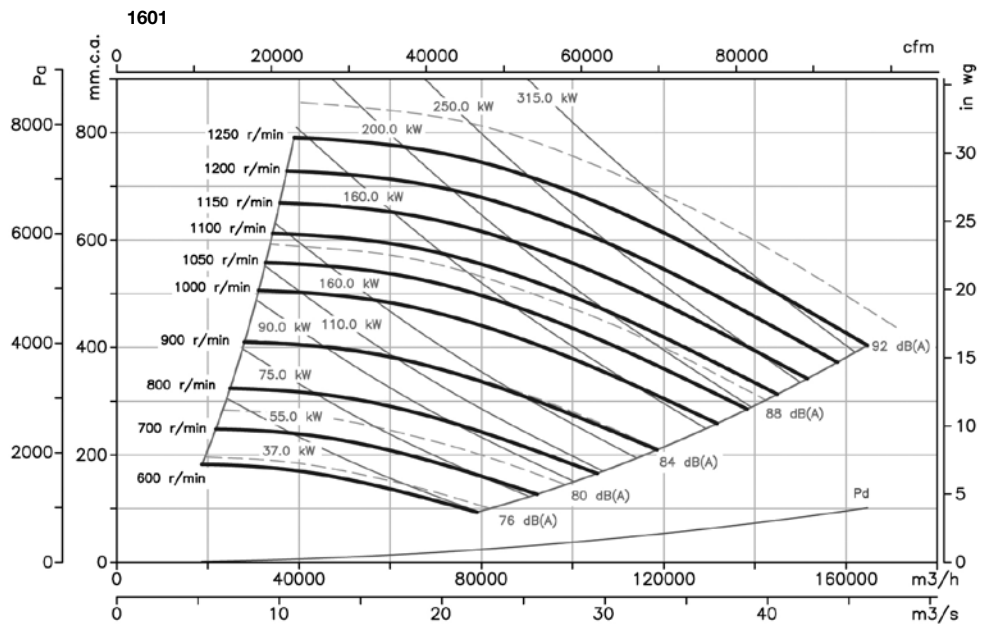
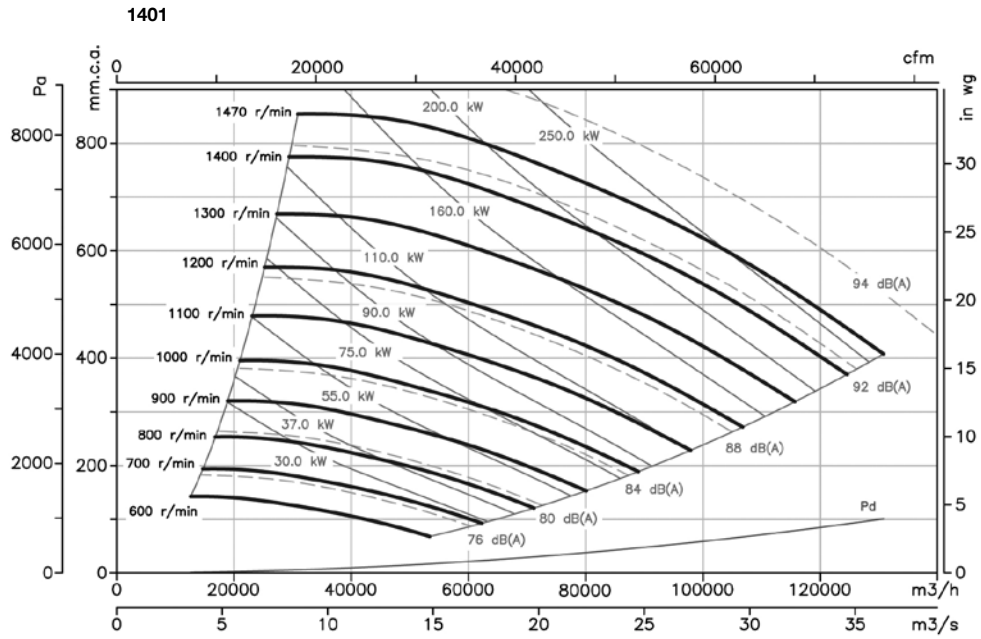

Positions

LG 270 standard supply

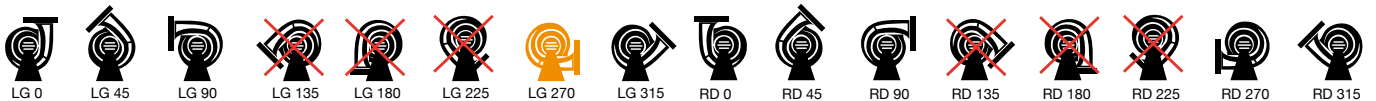

Accessories

See the accessories section.



CMP-X

Belt-driven fan with electric motor, pulley and belt kit and standardised protectors in accordance with standard EN-294 and ISO-13852



Axis protection guards and transmission in accordance with standards

Fan:

- Steel sheet casing
- Impeller with forward-facing blades made from galvanised sheet steel
- Version A: motor assembled on the housing
- Version B: motor mounted on general bedplate

Motor:

- Motors with IE-2 efficiency, except for motors with lower powers than 0.75 kW, monophase motors or two-speed motors
- Class F motors with ball bearings, IP55 protection
- Three-phase 230/400V.-50Hz. (up to 5.5CV.) and 400/690V.-50Hz. (power over 5.5CV.)
- Max. air temperature to transport: -20°C.+ 150°C.

Finish:

- Anticorrosive finish in polyester resin, polymerised at 190°C, after alkaline degreasing and phosphate-free pre-treatment.

On request:

- Special windings for different voltages
- Fan designed to transport air up to 250°C.
- Stainless steel fans
- ATEX certification, Category 2
- Straight-blade impellers

Order code

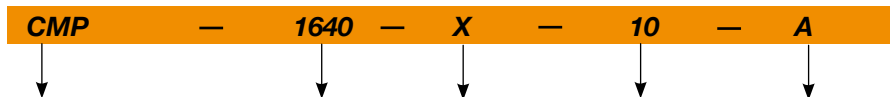

CMP-X: Belt-driven fan with electric motor, pulley and belt kit and standardised protectors in accordance with standard EN-294 and ISO-13852

Impeller size

Belt-driven fan

Power motor (c.v.)

Assembly type
A: Motor assembled on the housing
B: Motor mounted on general bedplate

Technical characteristics

Model	Speed (r/min)	Installed Power (kW)	Maximum Airflow (m ³ /h)	Maximum Pressure (mm w.c.)	Weight (Kg)	Assembly type
CMP-922-X-1	1600	0.75	2050	55	33	A
CMP-922-X-1.5	1800	1.1	2300	65	38	A
CMP-922-X-2	2000	1.5	2600	85	41	A
CMP-922-X-3	2270	2.2	2900	105	49	A
CMP-922-X-4	2570	3	3300	135	52	A
CMP-1025-X-1.5	1400	1.1	2700	50	45	A
CMP-1025-X-2	1550	1.5	3000	60	48	A
CMP-1025-X-3	1770	2.2	3400	80	56	A
CMP-1025-X-4	1980	3	3800	100	59	A
CMP-1025-X-5.5	2190	4	4200	120	71	A
CMP-1128-X-2	1290	1.5	3550	55	53	A
CMP-1128-X-3	1470	2.2	4050	75	61	A
CMP-1128-X-4	1650	3	4550	95	64	A
CMP-1128-X-5.5	1820	4	5000	115	76	A
CMP-1128-X-7.5	2020	5.5	5550	140	90	B
CMP-1231-X-3	1150	2.2	4550	50	66	A
CMP-1231-X-4	1280	3	5050	60	69	A
CMP-1231-X-5.5	1410	4	5600	70	81	A

Technical characteristics

Model	Speed (r/min)	Installed Power (kW)	Maximum Airflow (m³/h)	Maximum Pressure (mm w.c.)	Weight (Kg)	Assembly type
CMP-1231-X-7.5	1580	5.5	6250	90	95	B
CMP-1435-X-3	1100	2.2	4850	70	73	A
CMP-1435-X-4	1220	3	5350	90	76	A
CMP-1435-X-5.5	1350	4	5850	110	88	A
CMP-1435-X-7.5	1500	5.5	6500	135	102	A
CMP-1435-X-10	1670	7.5	7250	170	109	A
CMP-1640-X-4	1000	3	6650	65	94	A
CMP-1640-X-5.5	1100	4	7350	80	106	A
CMP-1640-X-7.5	1230	5	8200	100	120	A
CMP-1640-X-10	1350	7.5	9000	120	127	A
CMP-1845-X-5.5	1020	4	7250	115	116	A
CMP-1845-X-7.5	1130	5.5	8000	140	130	A
CMP-1845-X-10	1260	7.5	8950	170	137	A
CMP-1845-X-15	1430	11	10150	220	175	B
CMP-1845-X-20	1620	15	11500	285	191	B
CMP-2050-X-7.5	900	5.5	11700	105	150	A
CMP-2050-X-10	1000	7.5	13000	130	157	A
CMP-2050-X-15	1130	11	14700	165	195	A
CMP-2050-X-20	1270	15	16550	210	211	A
CMP-2563-X-7.5	650	5.5	14200	65	230	A
CMP-2563-X-10	720	7.5	15750	80	237	A
CMP-2563-X-15	820	11	17950	105	275	A
CMP-2563-X-20	920	15	20100	135	291	A
CMP-2563-X-25	990	18.5	21650	155	330	B
CMP-2563-X-30	1040	22	22750	170	353	B

Dimensions in mm

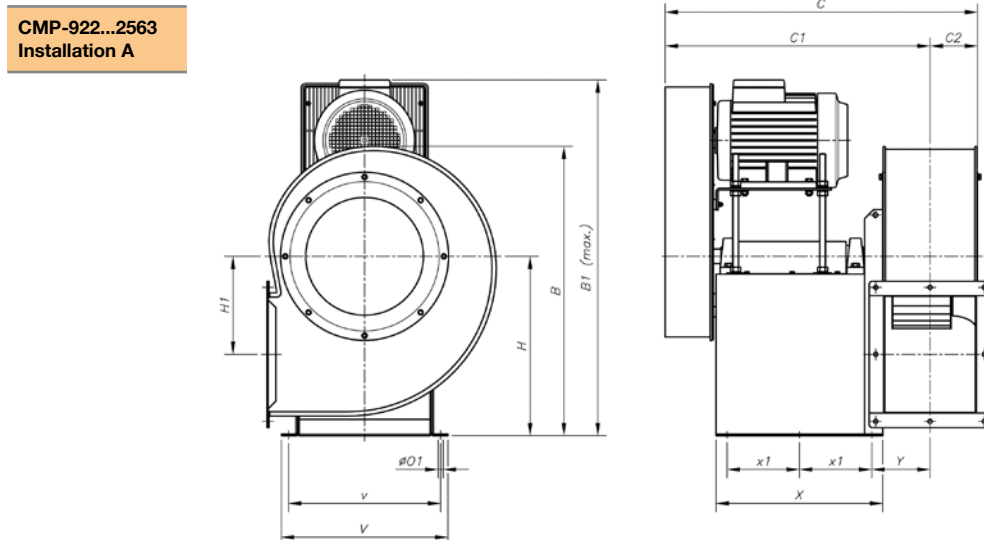

Model	A	B	B1	C	C1	C2	E	H	H1	øO1	V	v	X	X1	Y
CMP-922-X	388.5	455	655	589	515.5	73.5	180	280	134	12	340	310	350	150	100
CMP-1025-X	427	503	690	614	528	86	197	310	144	12	40	310	350	150	112.5
CMP-1128-X	472	553	725	660	566.5	93.5	216	340	152	12	350	320	380	160	125
CMP-1231-X	526	630	775	680	576.5	103.5	238	390	179.5	12	380	350	380	160	135
CMP-1435-X	573.5	715	940	838	720	118	250	445	242.5	12	440	400	460	200	149
CMP-1640-X	634	799	990	862	732	130	270	495	271	12	460	420	460	200	161
CMP-1845-X	711	901	1055	896	749	147	302	560	305	12	500	460	460	200	178
CMP-2050-X	797	987	1215	1068	905.5	162.5	345	610	313	14	540	500	600	275	189.5
CMP-2563-X	1027	1213	1350	1165	954	211	460	742	378.5	14	590	540	600	275	238

Dimensions in mm

**CMP-1128...2563
Installation B**

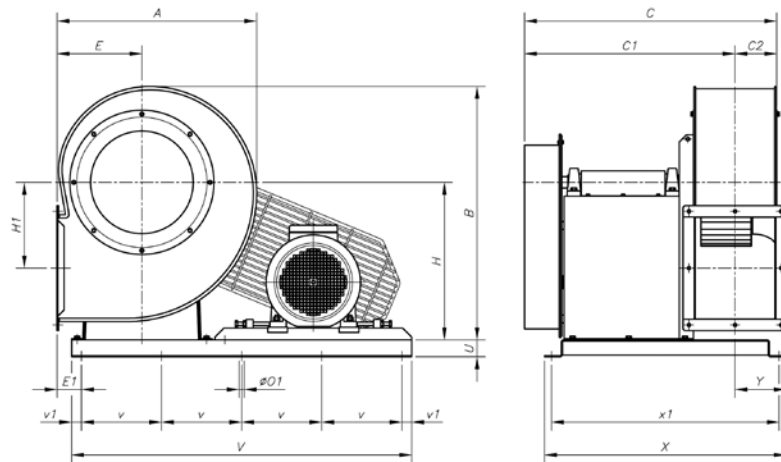

Model	A	B	C	C1	C2	E	E1	H	H1	ØO1	U	V	v1(*)	v1	X	X1	Y
CMP-1128-X	472	553	704	610.5	93.5	216	71	340	152	12	35	885	275	30	630	600	118
CMP-1231-X	526	630	724	620.5	103.5	238	118	390	179.5	12	35	980	280	70	660	630	138
CMP-1845-X	711	901	896	749	147	302	87	560	305	18	60	1210	285	35	860	810	182
CMP-2563-X	1027	1213	1165	954	211	460	195	742	378.5	18	60	1320	315	30	1200	1150	317

* Mod. 1128 - 1231 = 4 drilled holes. Mod. 1458 - 2563 = 5 drilled holes.

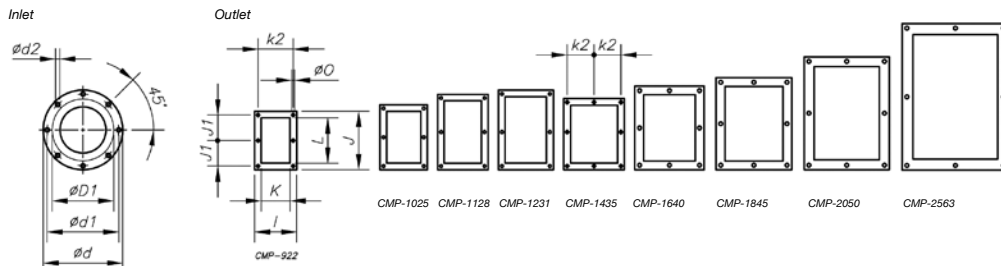

Model	ØD1	Ød	Ød1	Ød2	l	J	J1	K	k1	k2	L	ØO
CMP-922-X	224	278	256	M8	204	282.5	128	140	-	180	215	9.5
CMP-1025-X	250	305	282	M8	229	312.5	145	165	-	205	250	9.5
CMP-1128-X	280	348	320	M8	244	364	170	180	-	220	296.5	9.5
CMP-1231-X	315	382	354	M8	264	382.5	180	200	-	240	320	11.5
CMP-1435-X	355	422	394	M8	292	342.5	159	228	133	-	280	11.5
CMP-1640-X	400	464	438	M8	336	404	185	250	150	-	321	11.5
CMP-1845-X	450	515	485	M8	370	444	202	284	164	-	361	11.5
CMP-2050-X	500	565	535	M10	411	544	250	315	182.5	-	451	11.5
CMP-2563-X	630	710	675	M12	512	706	330	410	230	-	600	17

* Recommended nominal diameter for duct.

Characteristic Curves

Q = Airflow in m³/h, m³/s and cfm.

Pe = Static pressure in mm.w.c., Pa and in wg.

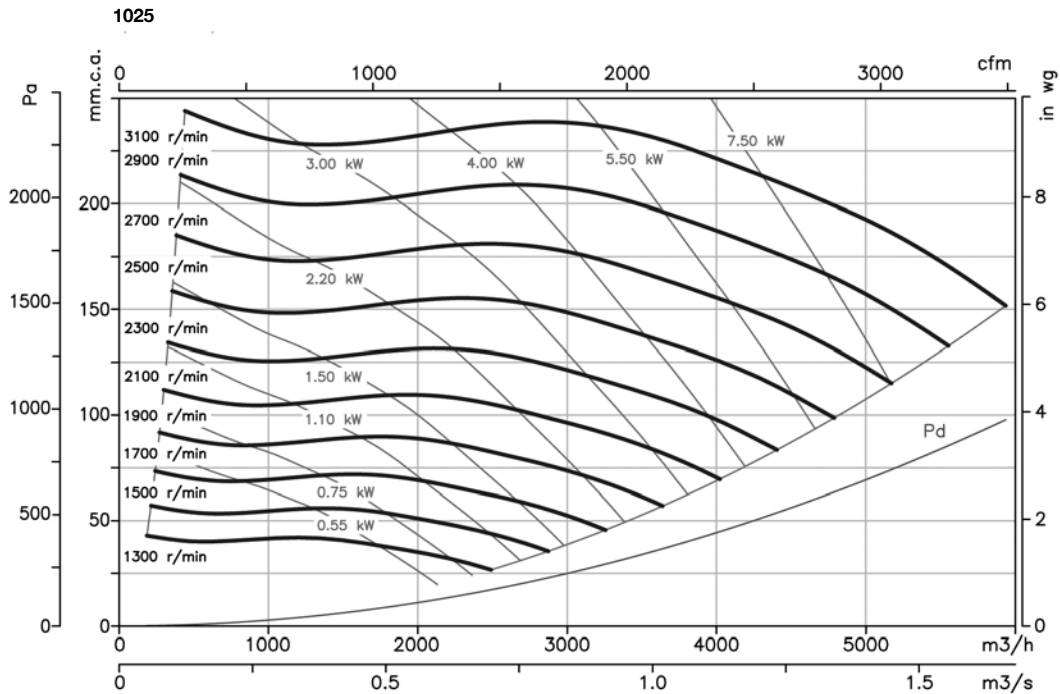
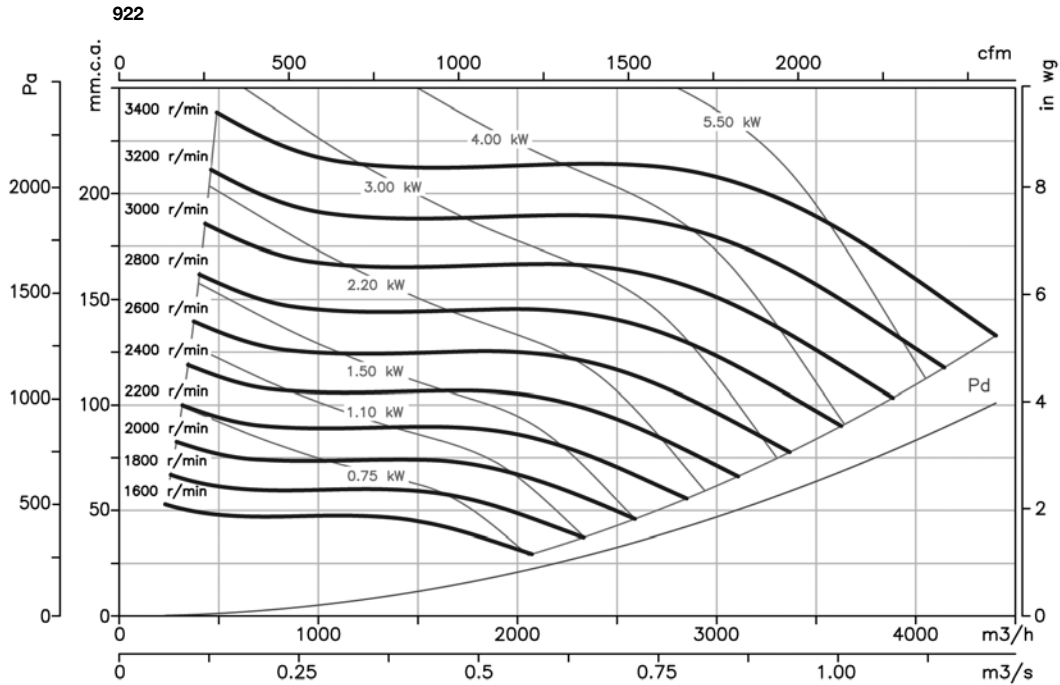

Characteristic Curves

Q = Airflow in m³/h, m³/s and cfm.

Pe= Static pressure in mm.w.c., Pa and in wg.

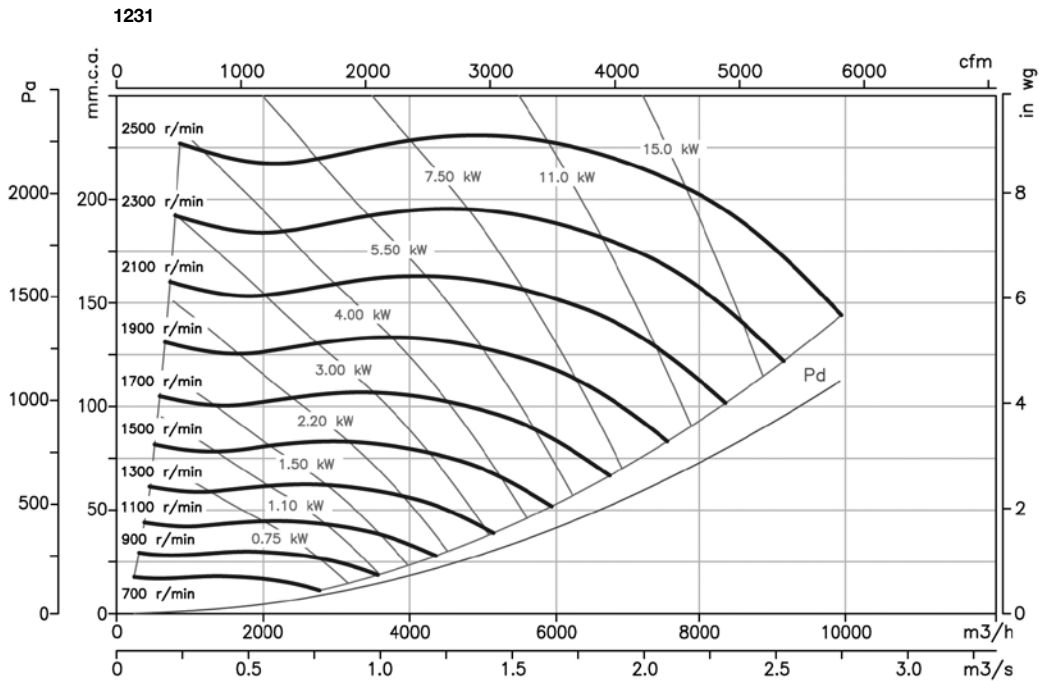
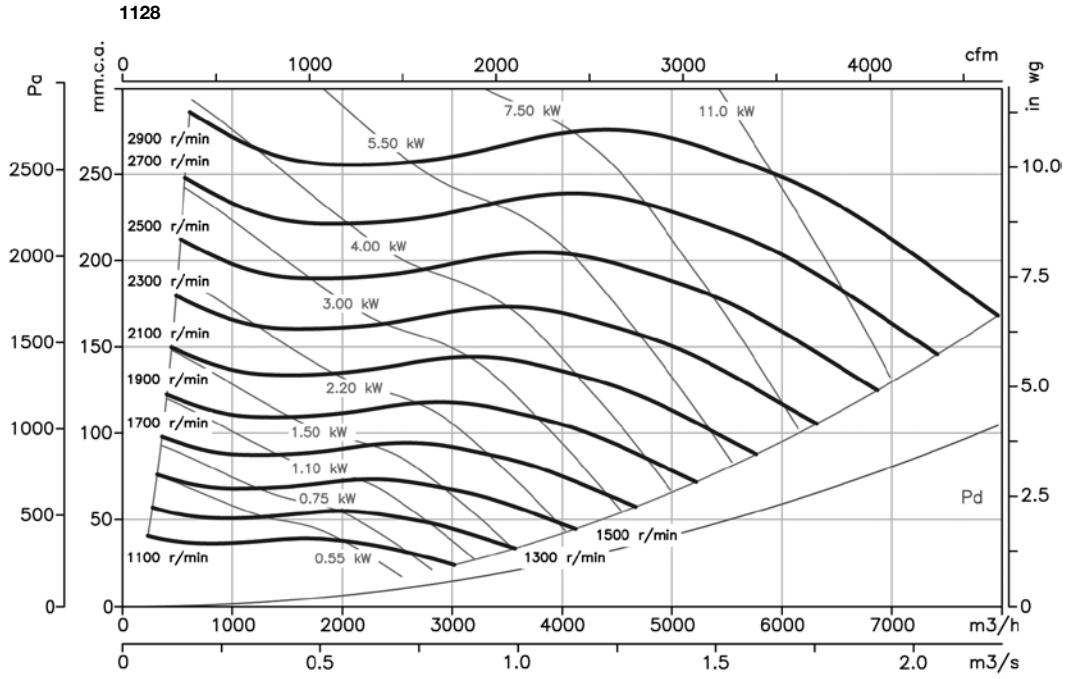

Characteristic Curves

Q = Airflow in m³/h, m³/s and cfm.

Pe = Static pressure in mm.w.c., Pa and in wg.

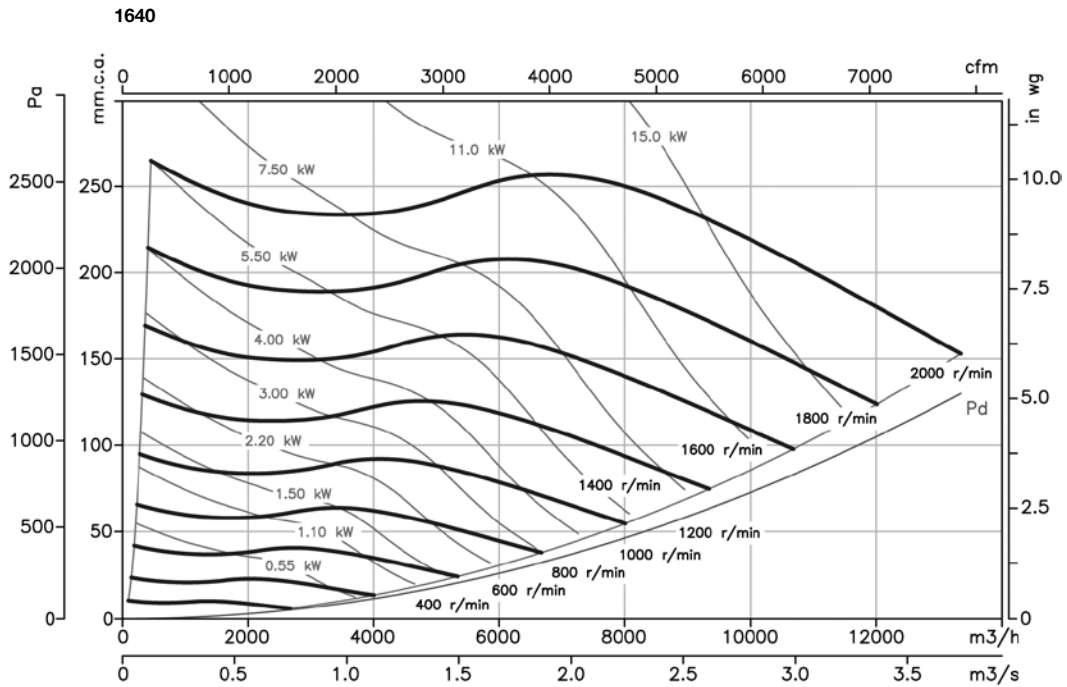
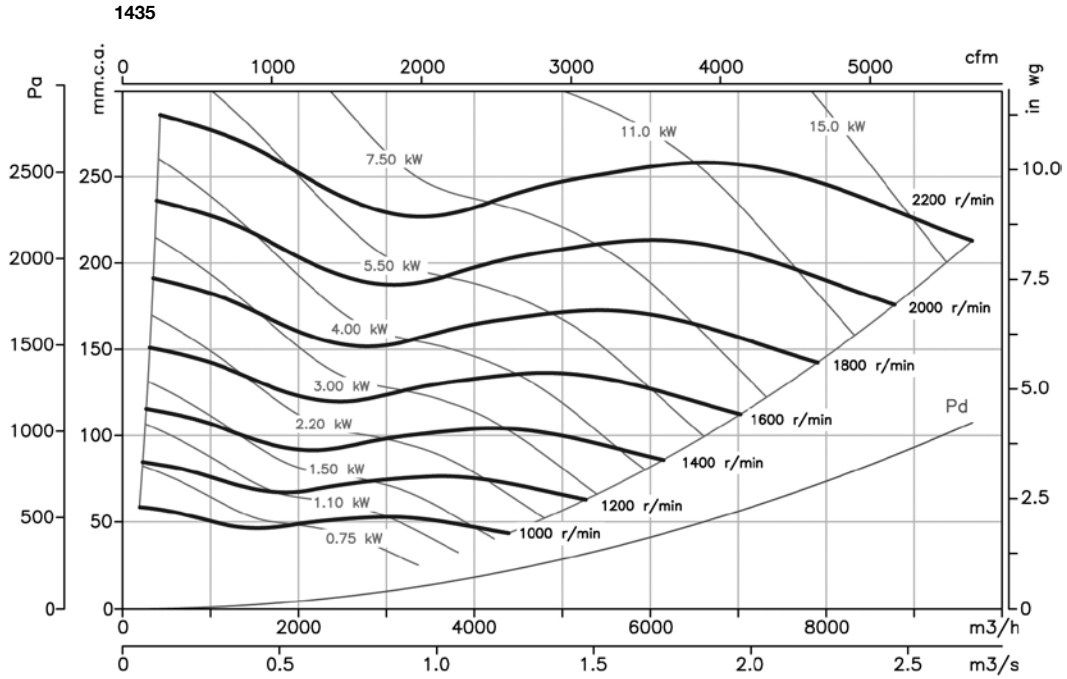

Characteristic Curves

Q = Airflow in m³/h, m³/s and cfm.

Pe= Static pressure in mm.w.c., Pa and in wg.

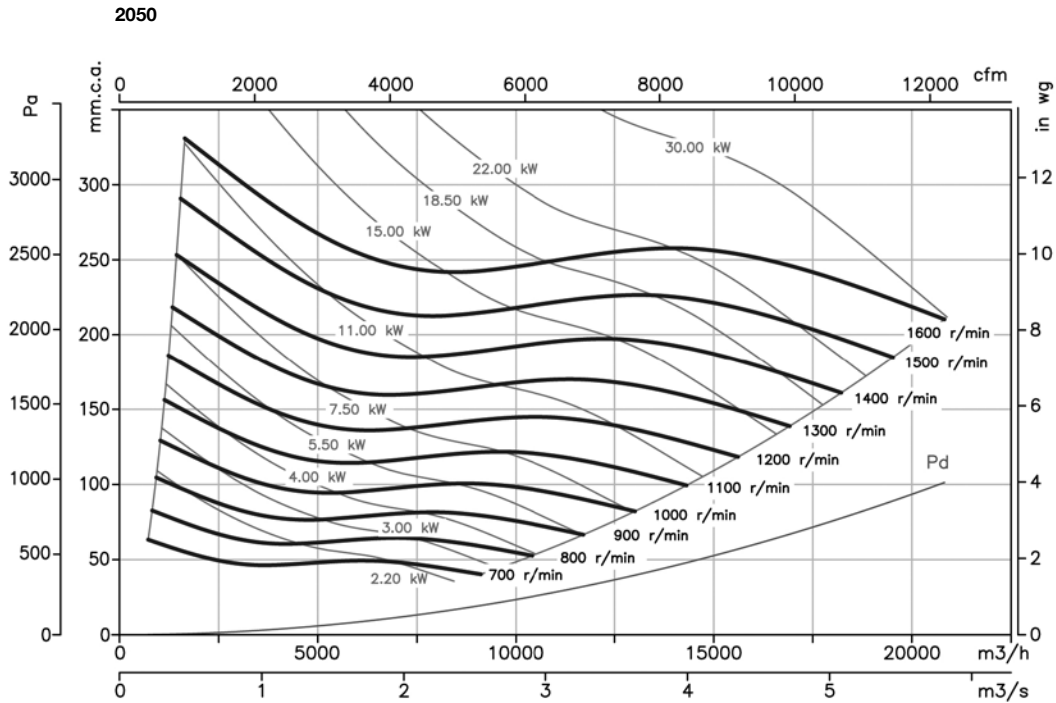
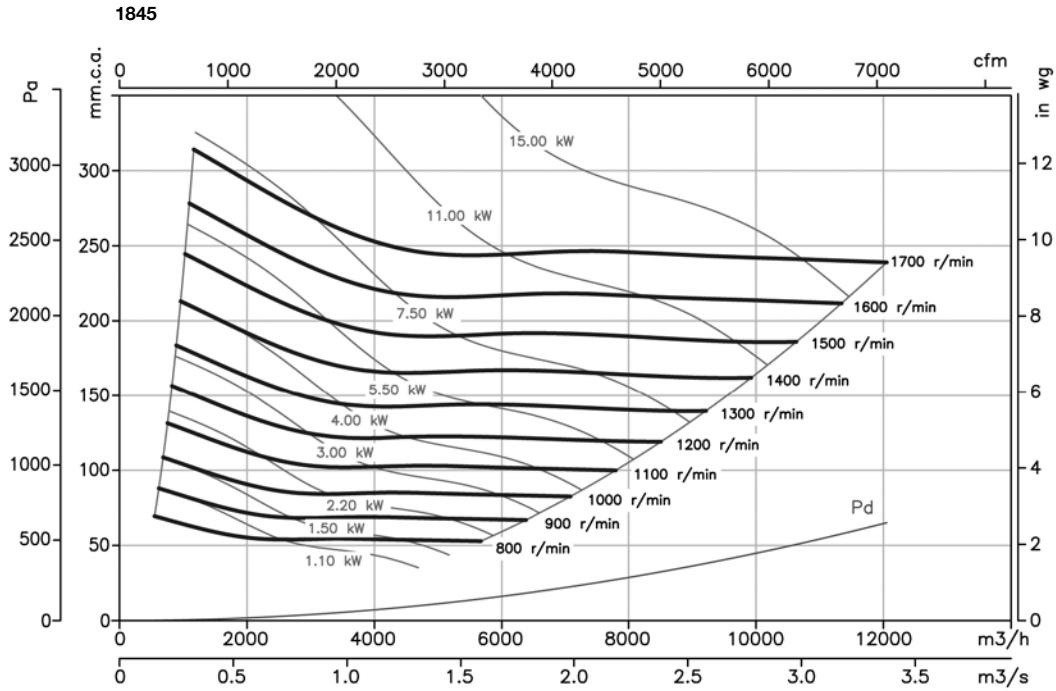

Characteristic Curves

Q = Airflow in m³/h, m³/s and cfm.

Pe = Static pressure in mm.w.c., Pa and in wg.

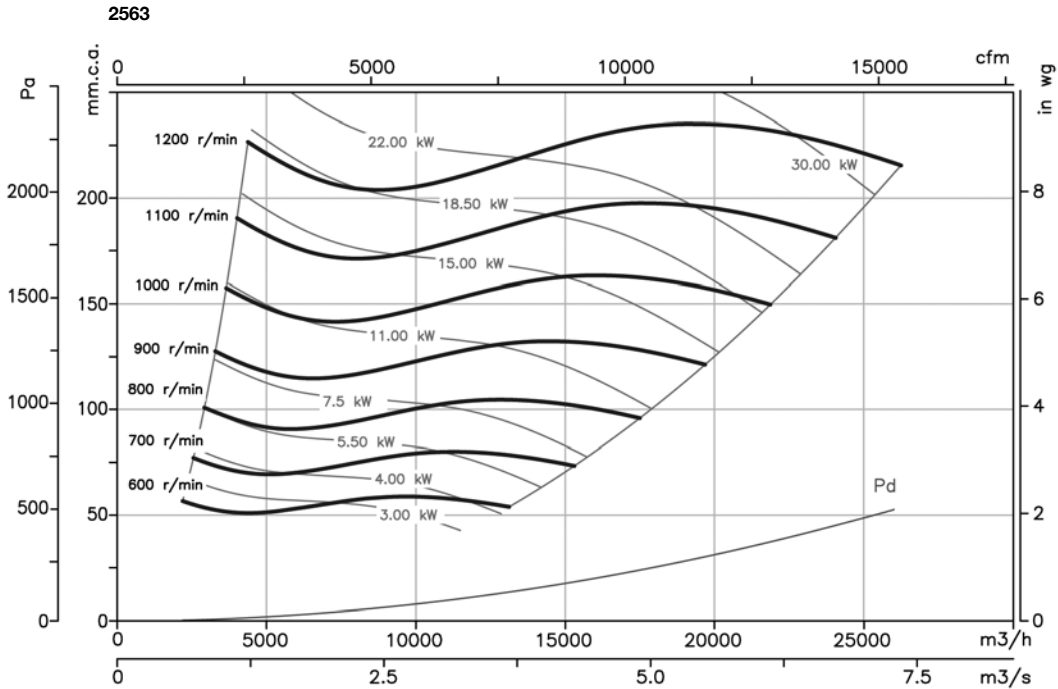

Positions

LG 270 standard supply

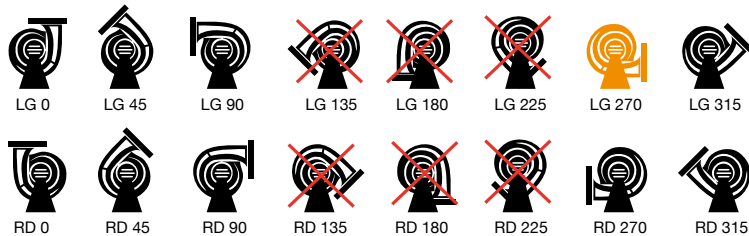

Accessories

See the accessories section.



CMR-X

Belt-driven fan with electric motor, pulley and belt kit and standardised protectors in accordance with standard EN-294 and ISO-13852



Fan:

- Steel sheet casing
- Impeller with backward-curved blades made from robust sheet steel
- Version A: motor assembled on the housing
- Version B: motor mounted on general bedplate



Robust build impeller

Motor:

- Motors with IE-2 efficiency, except for motors with lower powers than 0.75 kW, monophase motors or two-speed motors
- Class F motors with ball bearings, IP55 protection
- Three-phase 230/400V.-50Hz. (up to 5.5CV.) and 400/690V.-50Hz. (power over 5.5CV.)
- Max. air temperature to transport: -20°C.+ 150°C.

Finish:

- Anticorrosive finish in polyester resin, polymerised at 190°C, after alkaline degreasing and phosphate-free pre-treatment.

On request:

- Special windings for different voltages
- Fan designed to transport air up to 250°C.
- Stainless steel fans
- ATEX certification, Category 2

Order code

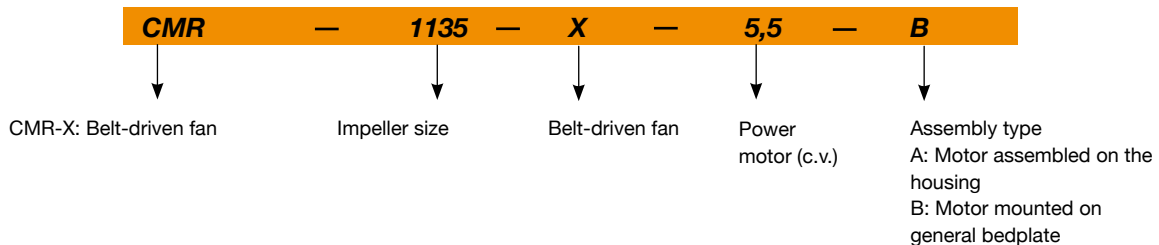

Technical characteristics

Model	Speed (r/min)	Installed Power (kW)	Maximum Airflow (m ³ /h)	Maximum Pressure (mm w.c.)	Weight (Kg)	Assembly type
CMR-1031-X-0.75	2050	0.55	3650	65	48	A
CMR-1031-X-1	2300	0.75	4100	85	49	A
CMR-1031-X-1.5	2600	1.1	4650	110	54	A
CMR-1031-X-2	2870	1.5	5100	130	57	A
CMR-1031-X-3	3270	2.2	5800	170	65	A
CMR-1031-X-4	3670	3	6550	215	68	A
CMR-1031-X-5.5	3820	4	6800	235	80	B
CMR-1135-X-1	1850	0.75	4700	65	53	A
CMR-1135-X-1.5	2080	1.1	5250	80	58	A
CMR-1135-X-2	2300	1.5	5800	100	61	A
CMR-1135-X-3	2630	2.2	6650	130	69	A

Technical characteristics

Model	Speed (r/min)	Installed Power (kW)	Maximum Airflow (m ³ /h)	Maximum Pressure (mm w.c.)	Weight (Kg)	Assembly type
CMR-1135-X-4	2950	3	7450	165	72	A
CMR-1135-X-5.5	3250	4	8200	200	84	B
CMR-1240-X-2	1840	1.5	7050	90	77	A
CMR-1240-X-3	2100	2.2	8050	120	85	A
CMR-1240-X-4	2350	3	9000	150	88	A
CMR-1240-X-5.5	2600	4	9950	180	100	A
CMR-1240-X-7.5	2870	5.5	11000	220	114	B
CMR-1445-X-3	1750	2.2	9900	100	104	A
CMR-1445-X-4	1960	3	11100	125	107	A
CMR-1445-X-5.5	2160	4	12200	155	119	A
CMR-1445-X-7.5	2400	5.5	13600	190	133	A
CMR-1445-X-10	2680	7.5	15150	235	140	A
CMR-1445-X-15	3040	11	17200	305	178	B
CMR-1650-X-4	1720	3	11150	115	132	A
CMR-1650-X-5.5	1880	4	12200	135	144	A
CMR-1650-X-7.5	2100	5.5	13600	170	158	A
CMR-1650-X-10	2340	7.5	15150	210	165	A
CMR-1650-X-15	2650	11	17150	270	203	A
CMR-1650-X-20	2800	15	18150	305	219	B
CMR-1856-X-5.5	1600	4	16650	120	159	A
CMR-1856-X-7.5	1770	5.5	18450	150	173	A
CMR-1856-X-10	1950	7.5	20300	180	180	A
CMR-1856-X-15	2200	11	22900	230	218	A
CMR-1856-X-20	2400	15	25000	270	234	A
CMR-2063-X-5.5	1220	4	20450	110	246	A
CMR-2063-X-7.5	1370	5.5	22950	135	260	A
CMR-2063-X-10	1500	7.5	25100	165	267	A
CMR-2063-X-15	1720	11	28800	215	305	A
CMR-2063-X-20	1930	15	32300	270	321	A
CMR-2063-X-25	2070	18.5	34650	310	360	A
CMR-2271-X-7.5	1080	5.5	25500	100	310	A
CMR-2271-X-10	1200	7.5	28350	125	317	A
CMR-2271-X-15	1370	11	32350	165	355	A
CMR-2271-X-20	1540	15	36400	205	371	A
CMR-2271-X-25	1650	18.5	39000	235	410	B
CMR-2380-X-10	940	7.5	32250	105	442	A
CMR-2380-X-15	1060	11	36350	130	480	A
CMR-2380-X-20	1200	15	41150	170	496	B
CMR-2380-X-25	1290	18.5	44250	195	535	B
CMR-2380-X-30	1370	22	46950	220	558	B
CMR-2590-X-20	1130	15	48250	170	681	B
CMR-2590-X-25	1200	18.5	51250	190	720	B
CMR-2590-X-30	1280	22	54700	220	743	B
CMR-2590-X-40	1430	30	61100	270	793	B
CMR-2590-X-50	1520	37	64950	310	910	B
CMR-2590-X-60	1630	45	69650	355	942	B
CMR-28100-X-30	1050	22	63500	185	1152	B
CMR-28100-X-40	1165	30	70450	230	1202	B
CMR-28100-X-50	1250	37	75600	260	1319	B
CMR-28100-X-60	1340	45	81050	300	1351	B
CMR-28100-X-75	1430	55	86500	345	1429	B
CMR-28100-X-100	1525	75	92250	390	1704	B
CMR-25112-X-30	880	22	73900	165	933	B
CMR-25112-X-40	970	30	81500	200	983	B
CMR-25112-X-50	1040	37	87350	230	1100	B
CMR-25112-X-60	1110	45	93250	265	1132	B
CMR-25112-X-75	1180	55	99100	295	1210	B
CMR-25112-X-100	1310	75	110050	365	1485	B

Technical characteristics

Model	Speed (r/min)	Installed Power (kW)	Maximum Airflow (m³/h)	Maximum Pressure (mm w.c.)	Weight (Kg)	Assembly type
CMR-28125-X-40	800	30	96000	170	1358	B
CMR-28125-X-50	860	37	103200	195	1475	B
CMR-28125-X-60	920	45	110400	225	1507	B
CMR-28125-X-75	980	55	117600	255	1585	B
CMR-28125-X-100	1090	75	130800	315	1860	B
CMR-28125-X-125	1160	90	139200	355	1927	B
CMR-32140-X-50	690	37	113850	160	2023	B
CMR-32140-X-60	740	45	12100	180	2055	B
CMR-32140-X-75	790	55	130350	210	2133	B
CMR-32140-X-100	875	75	144400	255	2408	B
CMR-32140-X-125	930	90	153450	290	2475	B
CMR-32140-X-150	1000	110	165000	335	2538	B
CMR-36160-X-75	680	55	145850	195	2590	B
CMR-36160-X-100	750	75	160900	240	2865	B
CMR-36160-X-125	800	90	171600	270	2932	B
CMR-36160-X-150	860	110	184450	315	2995	B
CMR-36160-X-175	910	125	195200	350	3067	B
CMR-36160-X-220	970	160	208050	400	3140	B

Dimensions in mm

CMR-1031...1856 Installation A

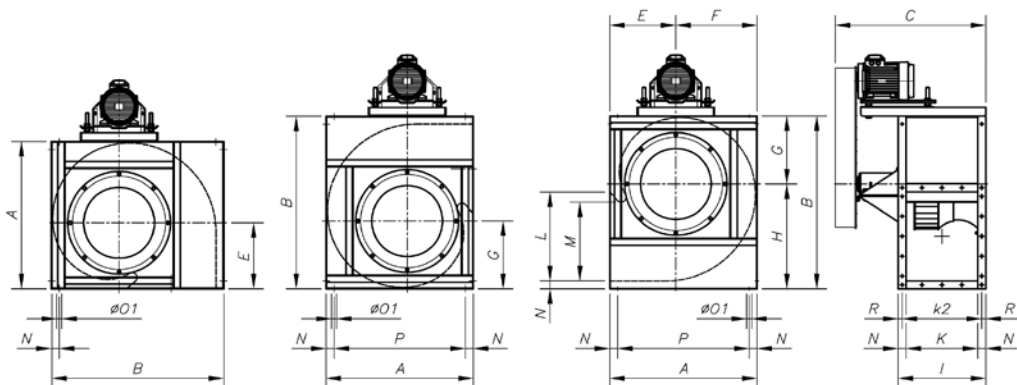

Model	A	B	C	E	F	G	H	I	K	k2	L	M	N	ø01	P	R
CMR-1031-X	542	626	666	250	292	245	381	320	250	285	315	276	35	11	472	17.5
CMR-1135-X	600	696	697	275	325	273	423	350	280	315	355	310	35	11	530	17.5
CMR-1240-X	673	790	738	305	368	310	480	395	315	355	400	358	40	11	593	20
CMR-1445-X	765	880	789	350	415	339	541	445	355	405	450	407	45	11	675	20
CMR-1650-X	832	970	883	375	457	378	592	490	400	450	500	445	45	13	742	20
CMR-1856-X	925	1084	938	415	510	426	658	550	450	500	560	493	50	13	825	25

CMR-2063...2380 Installation A

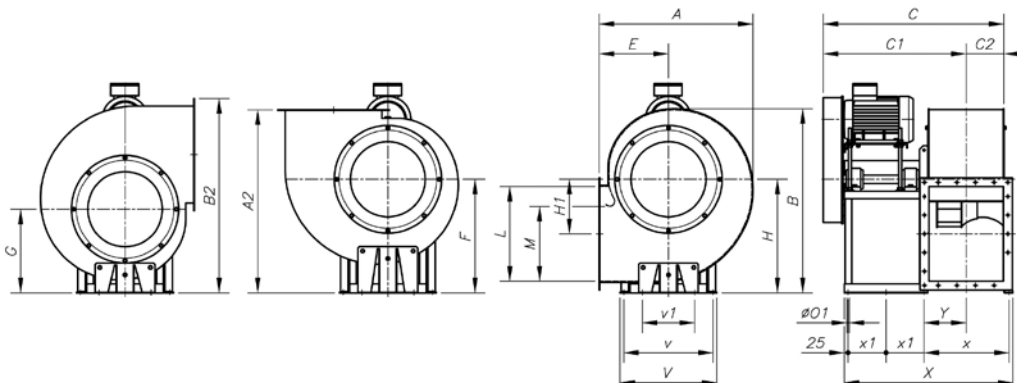

Model	A	A2	B	B2	C	C1	C2	E	F	G	H	H1	L	M	ø01	V	v	v1	X	x	x1	Y
CMR-2063-X	1033	1105	1232	1380	1215	959	256	465	640	640	760	365	630	530	14	650	600	350	1131	571	255	383
CMR-2271-X	1168	1225	1382	1536	1277	990	287	525	700	700	850	416	710	603	14	750	700	350	1193	633	255	314
CMR-2380-X	1487	1530	1722	1883	1318	1031	287	680	850	850	1050	410	1120	710	14	1015	960	350	1235	635	275	315

Dimensions in mm

**CMR-1031...1856
Installation B**

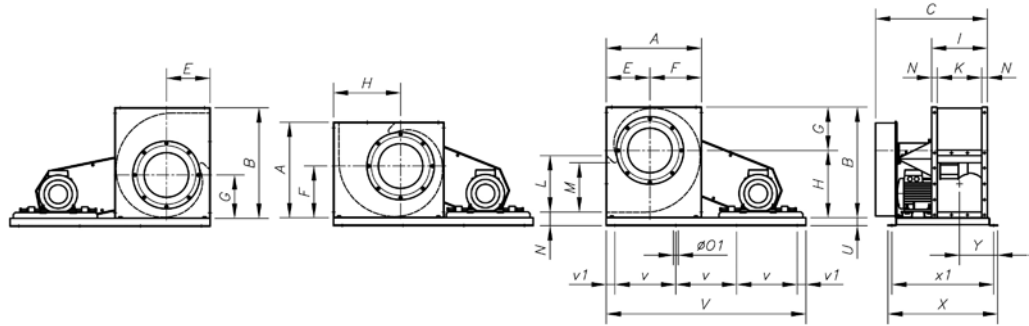

MODEL	A	B	C	E	F	G	H	I	K	L	M	N	øO1	U	V	v	v1	X	x1	Y
CMR-1031-X	542	626	666	250	292	245	381	320	250	315	276	35	11	50	1400	430	55	690	640	225
CMR-1135-X	600	696	697	275	325	273	423	350	280	355	310	35	11	50	1400	430	55	690	640	240
CMR-1240-X	673	790	738	305	368	310	480	395	315	400	358	40	11	50	1600	490	65	780	730	257
CMR-1445-X	765	880	789	350	415	339	541	445	355	450	407	45	11	50	1600	490	65	800	7550	283
CMR-1650-X	832	970	883	375	457	378	592	490	400	500	445	45	13	60	1800	550	75	920	860	331
CMR-1856-X	925	1084	938	415	510	426	658	550	450	560	493	50	13	60	1800	550	75	970	910	350

**CMR-2063...2380
Installation B**

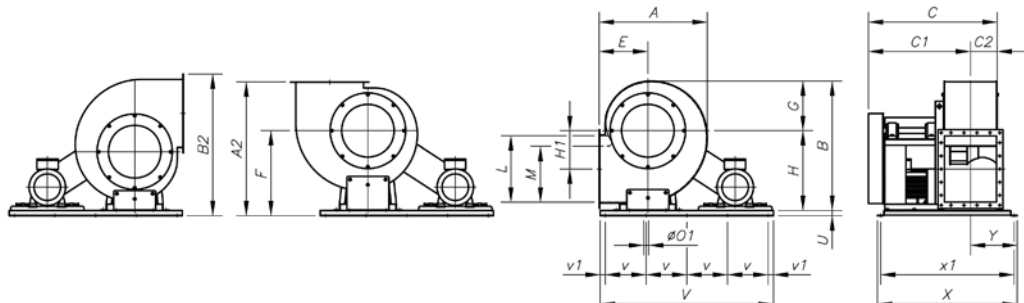

Model	A	A2	B	B2	C	C1	C2	E	E1	F	G	H	H1	L	M	øO1	U	V	v	v1	X	x1	Y	Z
CMR-2063-X	1033	1105	1232	1380	1215	959	256	465	60	640	640	760	365	630	530	14	50	1780	420	50	1335	1275	447	455
CMR-2271-X	1168	1225	1382	1536	1277	990	287	525	70	700	700	850	416	710	603	14	50	1780	420	50	1335	1275	416	505
CMR-2380-X	1487	1530	1722	1883	1318	1031	287	680	75	850	850	1050	410	1120	710	14	80	1900	450	50	1420	1360	440	508

**CMR-2590...36160
Installation B**

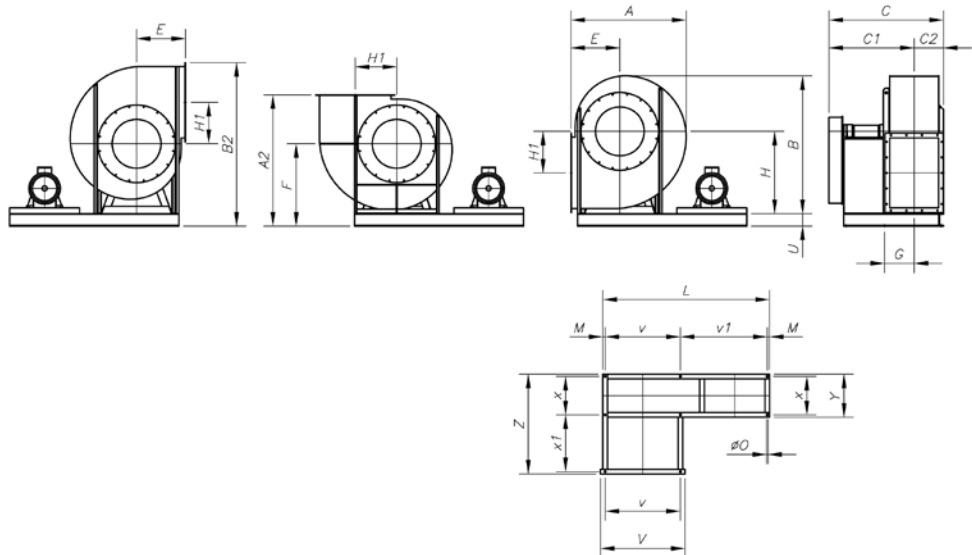

Model	A	A2	B	B2	C	C1	C2	E	F	G	H	H1	L	M	øO	U	V	v	v1	x	x1	Y	Z
CMR-2590-X	1495	1690	1785	2130	1470	1090	320.5	630	1060	383	1060	535	2150	30	19	160	1090	970	1120	495	731	555	1286
CMR-28100-X	1680	1890	1990	2360	1695	1274	362	710	1180	429	1180	610	2250	35	21	180	1190	1060	1120	600	818	660	1478
CMR-25112-X	4890	2100	2230	2630	1805	1321	407	800	1300	469	1320	690	2390	35	24	180	1350	1200	1120	600	908	670	1578
CMR-28125-X	2010	2260	2480	2910	1985	1451	462	830	1430	529	1500	775	2520	40	24	180	1480	1320	1120	670	1023	750	1773
CMR-32140-X	2270	2450	2750	2950	2190	1606	512	950	1500	599	1650	860	2700	40	24	180	1660	1500	1120	750	1143	830	1973
CMR-36160-X	2535	2740	3075	3265	2390	1746	572	1060	1680	654	1850	945	2900	40	24	180	1860	1700	1120	800	1258	880	2138

Dimensions in mm

Inlets/ outlets

Inlet

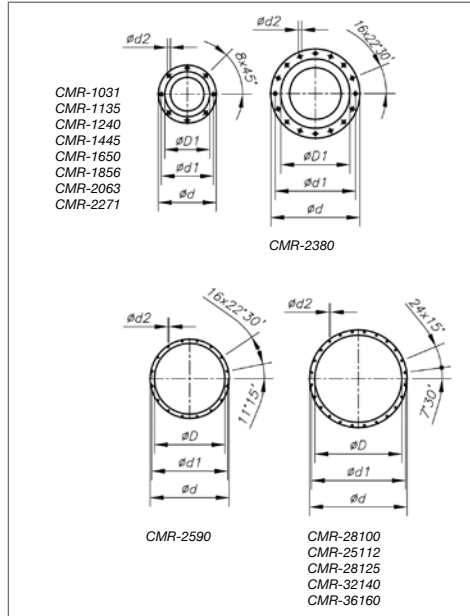

Outlet

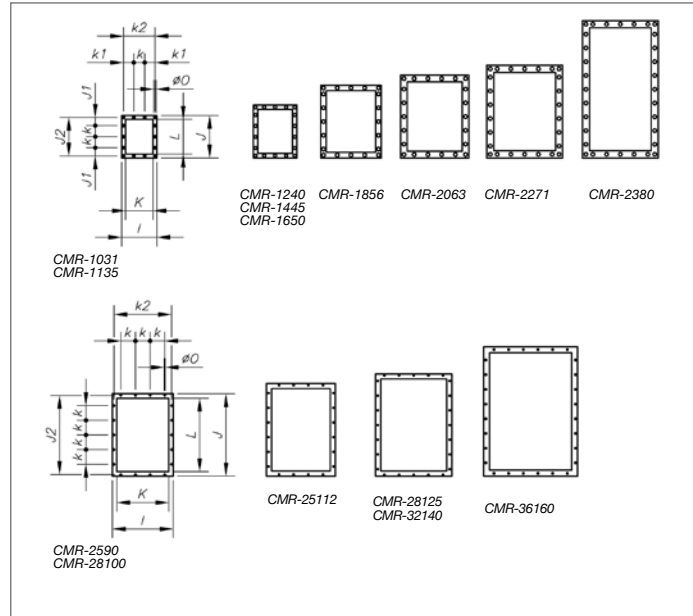

Model	øD1*	ød	ød1	ød2	I	J	J1	J2	K	k	k1	k2	L	øO
CMR-1031-X	315	383	356	M8	320	385	75	350	250	100	92.5	285	315	11
CMR-1135-X	355	425	398	M8	350	425	95	390	280	100	107.5	315	355	11
CMR-1240-X	400	472	444	M10	395	480	70	440	315	100	77.5	355	400	11
CMR-1445-X	450	522	494	M10	445	540	99	495	355	100	102.5	405	450	11
CMR-1650-X	500	582	555	M10	490	590	87.5	550	400	125	100	450	500	13
CMR-1856-X	560	645	615	M10	550	660	55	610	450	125	125	500	560	13
CMR-2063-X	630	720	688	M12	620	750	95	690	500	125	92.5	560	632	13
CMR-2271-X	710	800	768	M12	690	840	75	775	560	125	62.5	625	710	13
CMR-2380-X	800	910	861	M12	690	1246	93	1186	562	125	62.5	625	1122	13
CMR-2590-X	908	1008	958	14	750	1020	-	968	630	200	-	708	900	14
CMR-28100-X	1008	1108	1067	14	830	1120	-	1077	710	200	-	785	1000	14
CMR-25112-X	1130	1250	1200	14	940	1260	-	1210	800	200	-	881	1120	18
CMR-28125-X	1260	1380	1337	14	1040	1390	-	1347	900	200	-	978	1250	18
CMR-32140-X	1420	1540	1491	16	1160	1560	-	1501	1000	200	-	1087	1400	18
CMR-36160-X	1610	1730	1663	16	1280	1760	-	1683	1120	200	-	1220	1600	22

Characteristic Curves

Q = Airflow in m³/h, m³/s and cfm.

Pe = Static pressure in mm.w.c., Pa and in wg.

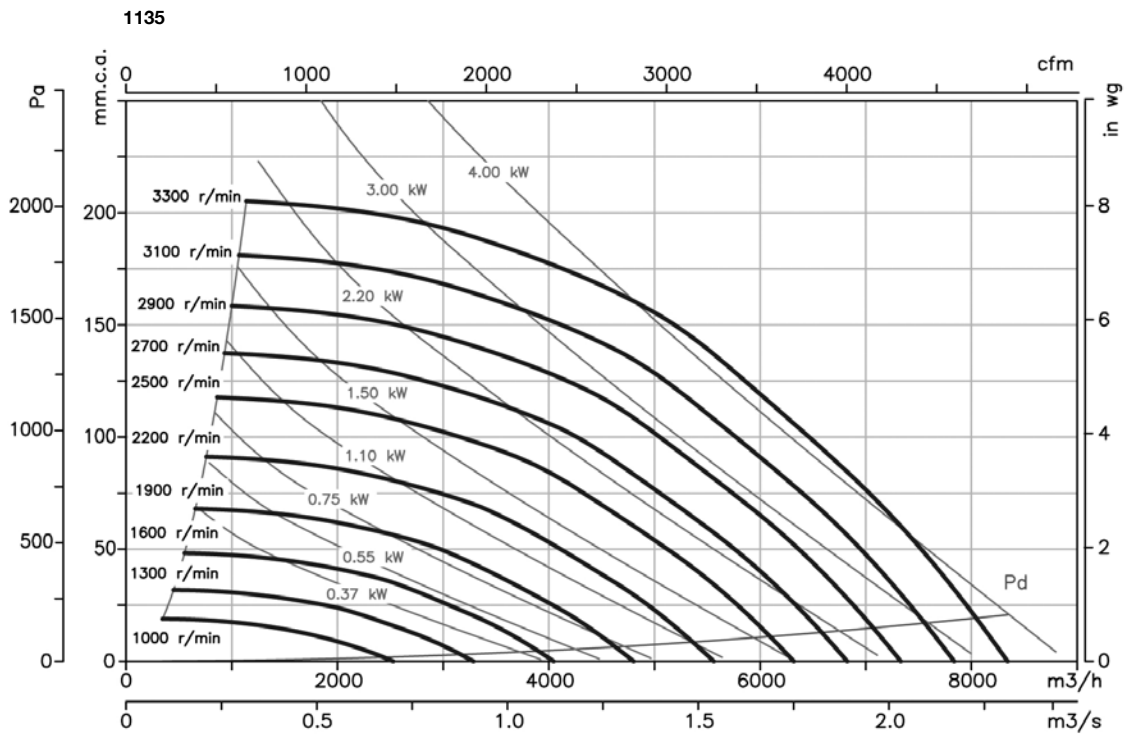
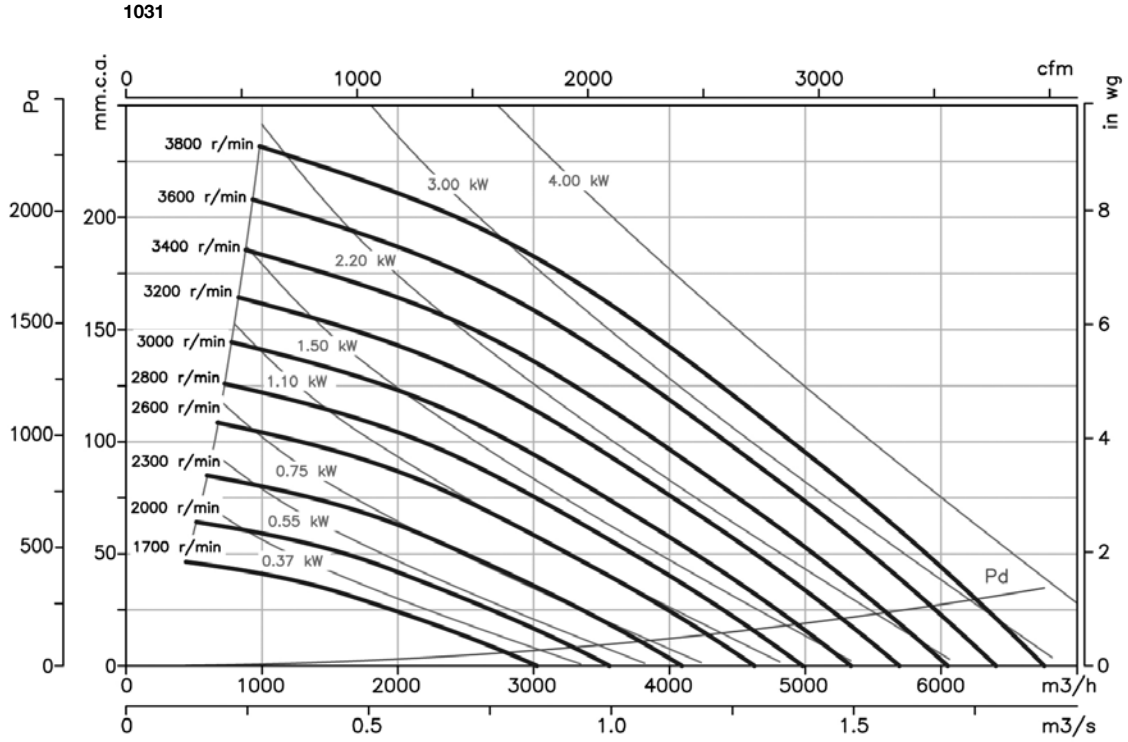

Characteristic Curves

Q = Airflow in m³/h, m³/s and cfm.

Pe= Static pressure in mm.w.c., Pa and in wg.

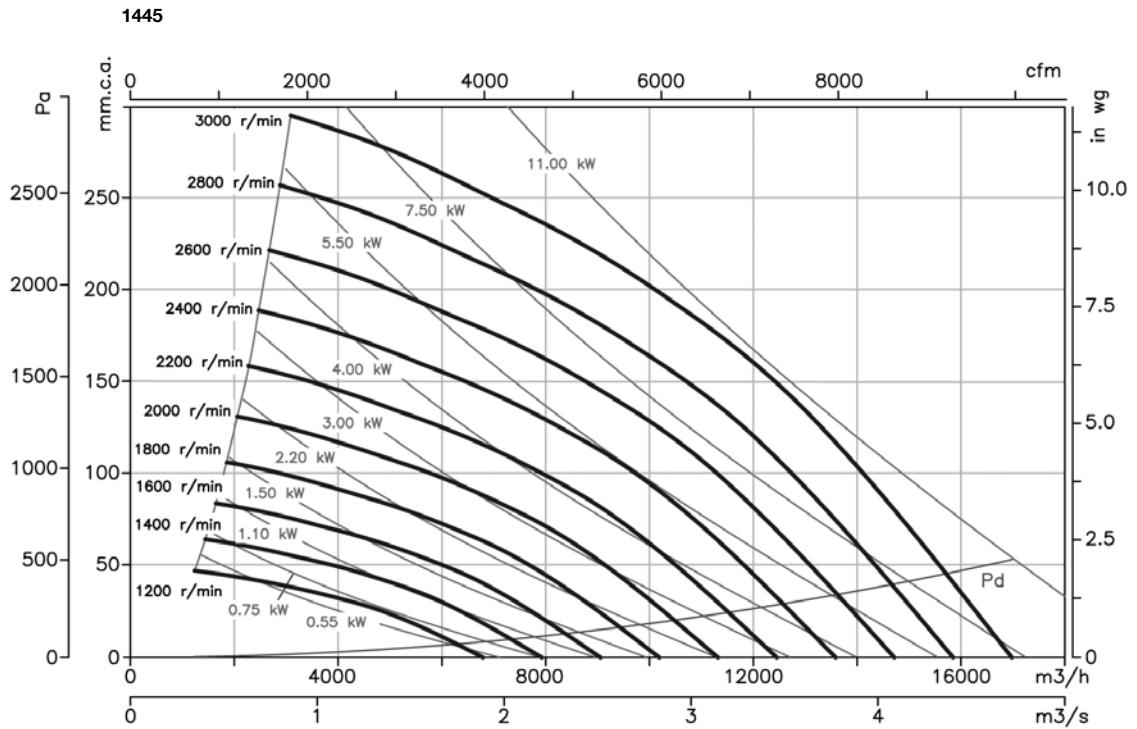
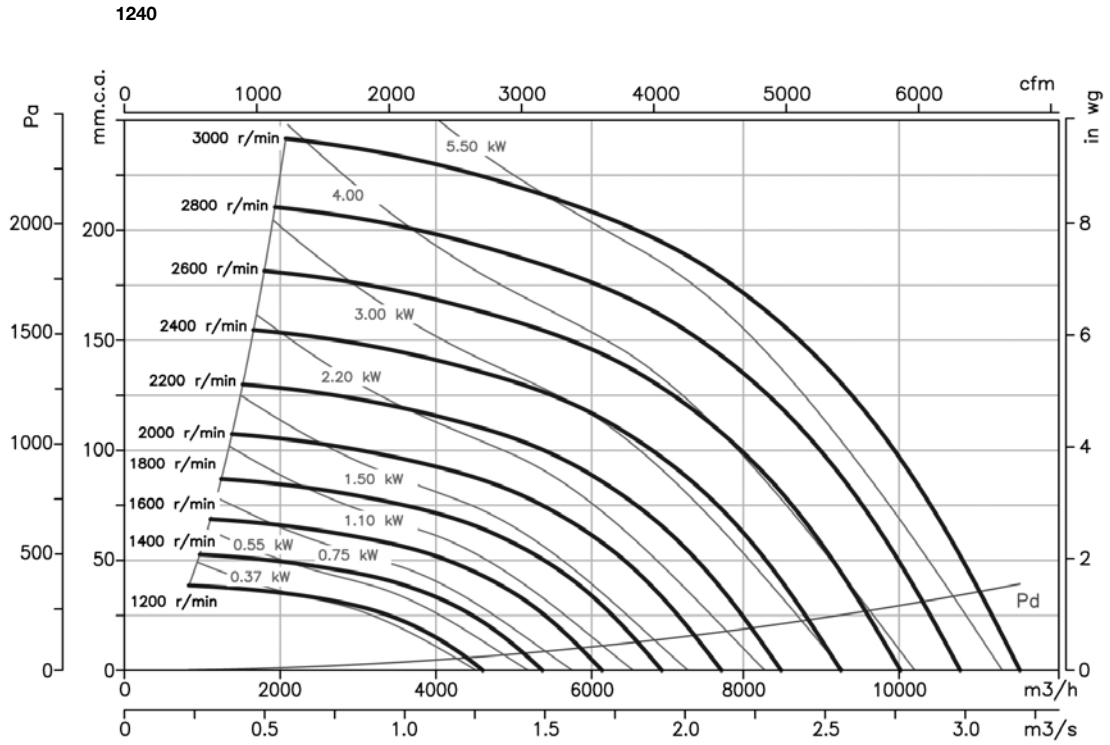

Characteristic Curves

Q = Airflow in m³/h, m³/s and cfm.

Pe = Static pressure in mm.w.c., Pa and in wg.

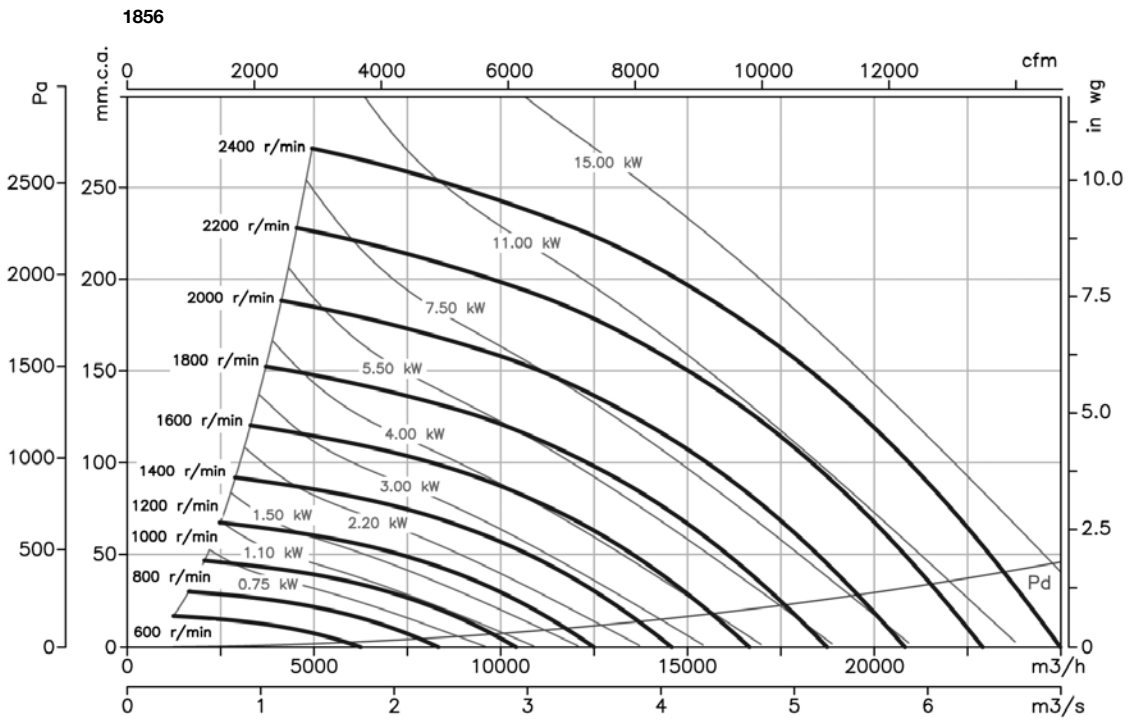
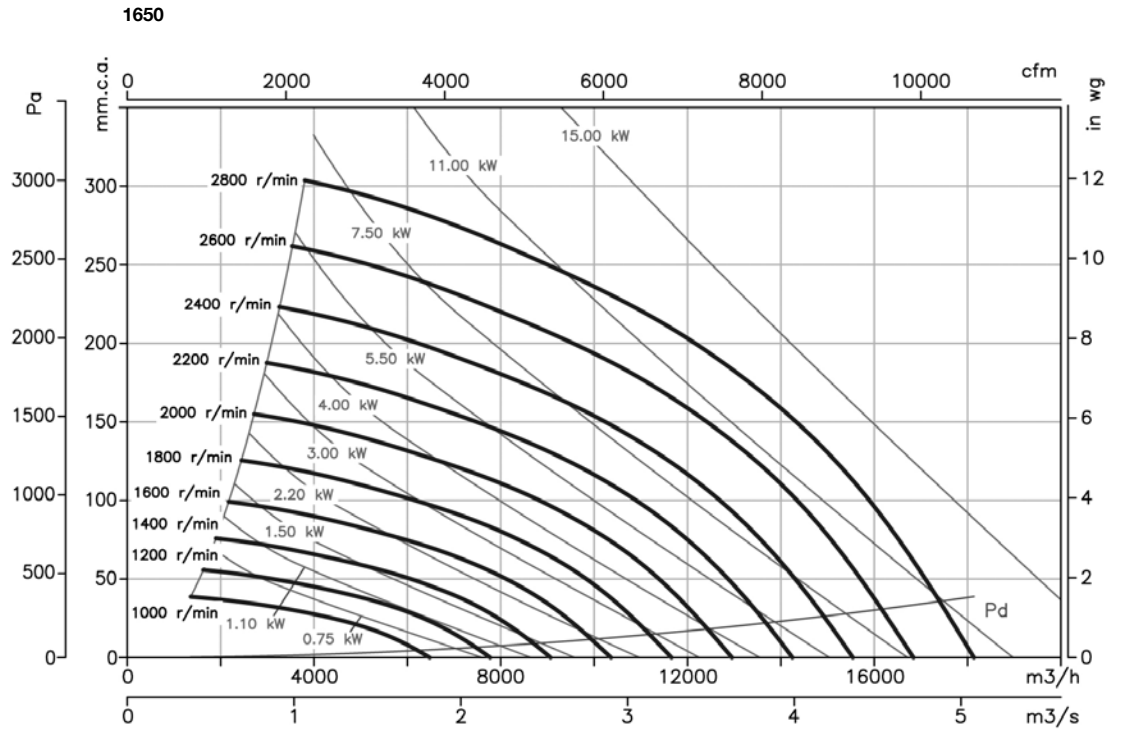

Characteristic Curves

Q = Airflow in m³/h, m³/s and cfm.

Pe = Static pressure in mm.w.c., Pa and in wg.

2063

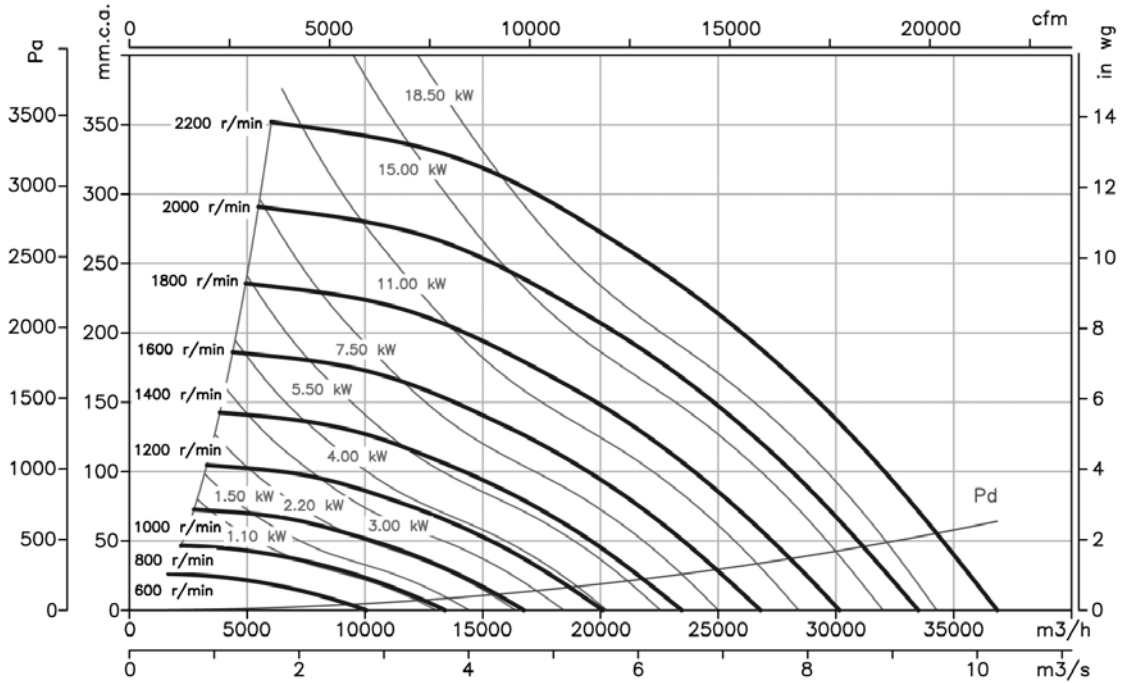

2271

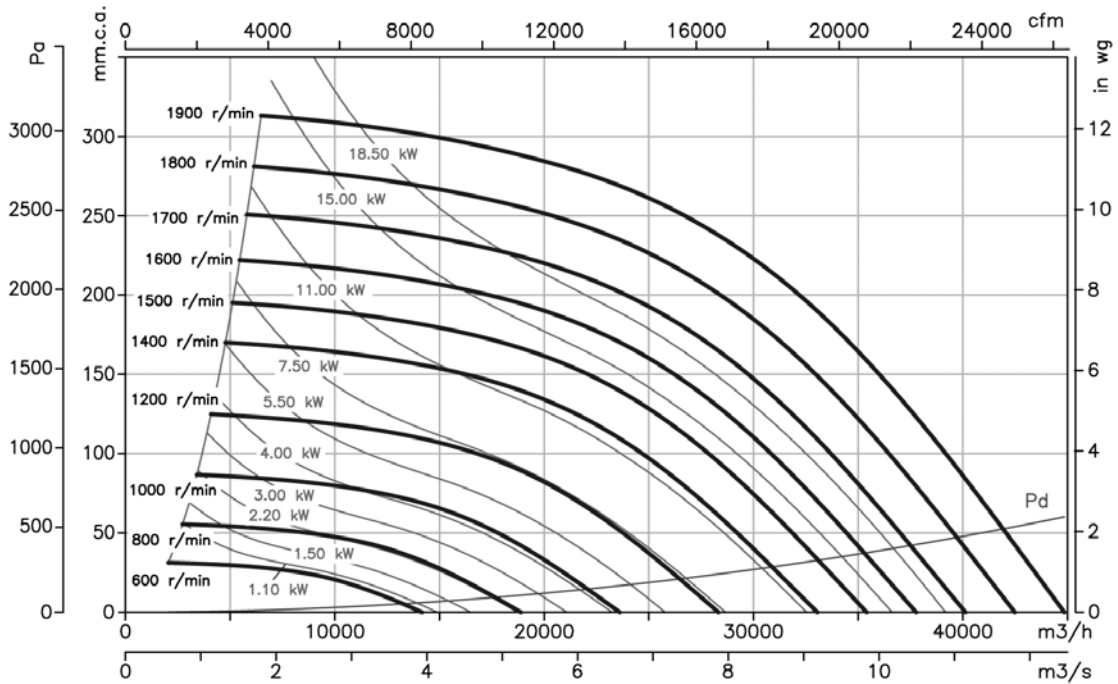

Characteristic Curves

Q = Airflow in m³/h, m³/s and cfm.

Pe = Static pressure in mm.w.c., Pa and in wg.

2380

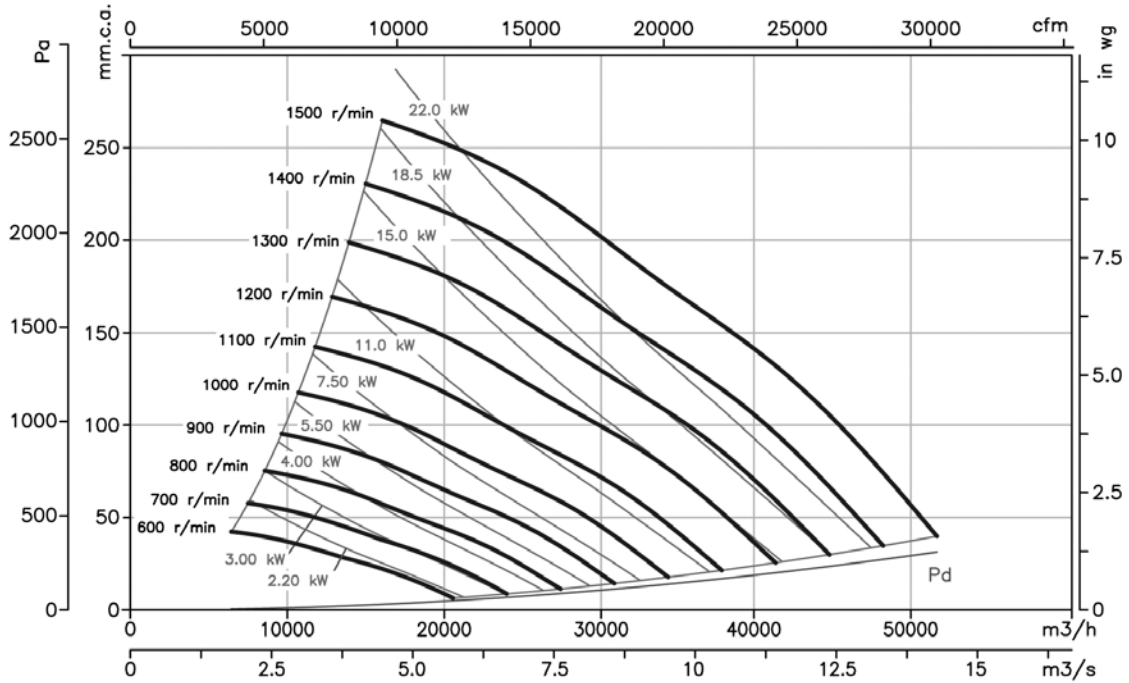

2590

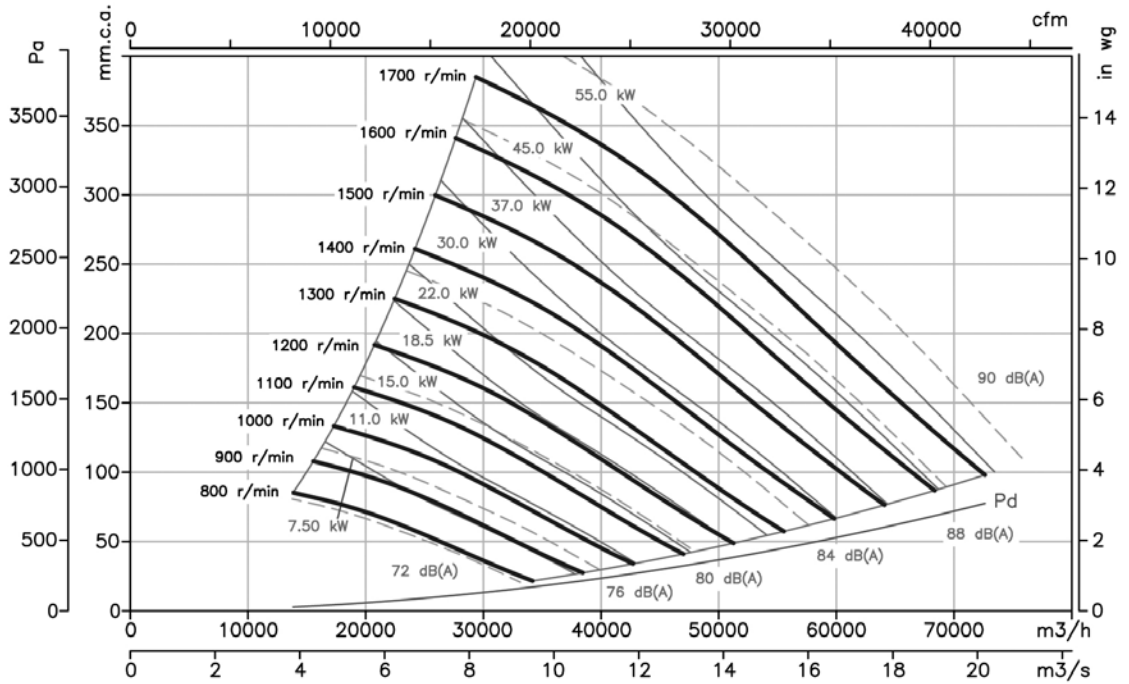

Characteristic Curves

Q = Airflow in m³/h, m³/s and cfm.

Pe = Static pressure in mm.w.c., Pa and in wg.

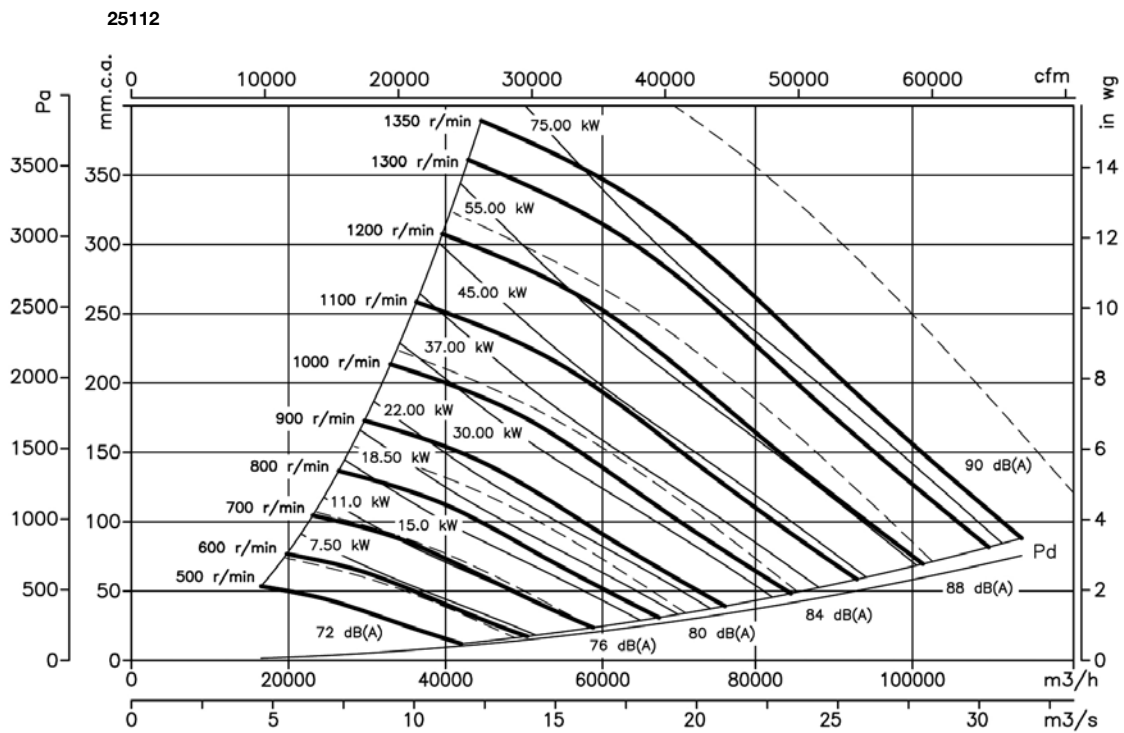
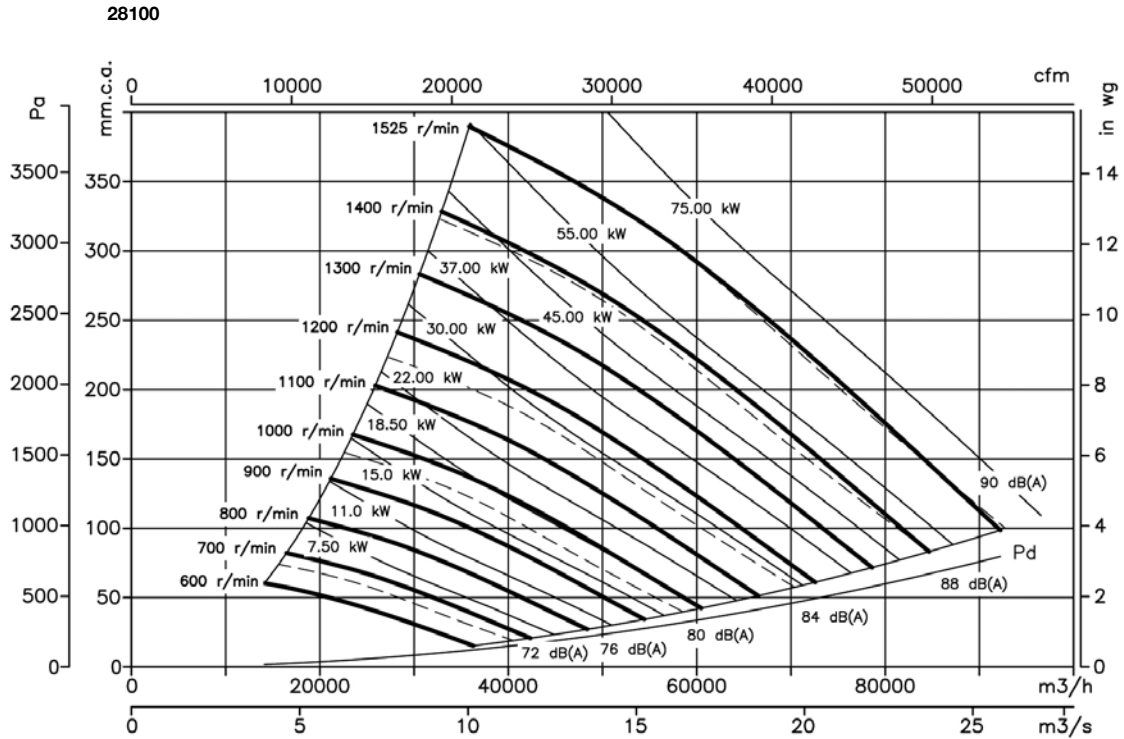

Characteristic Curves

Q = Airflow in m³/h, m³/s and cfm.

Pe = Static pressure in mm.w.c., Pa and in wg.

28125

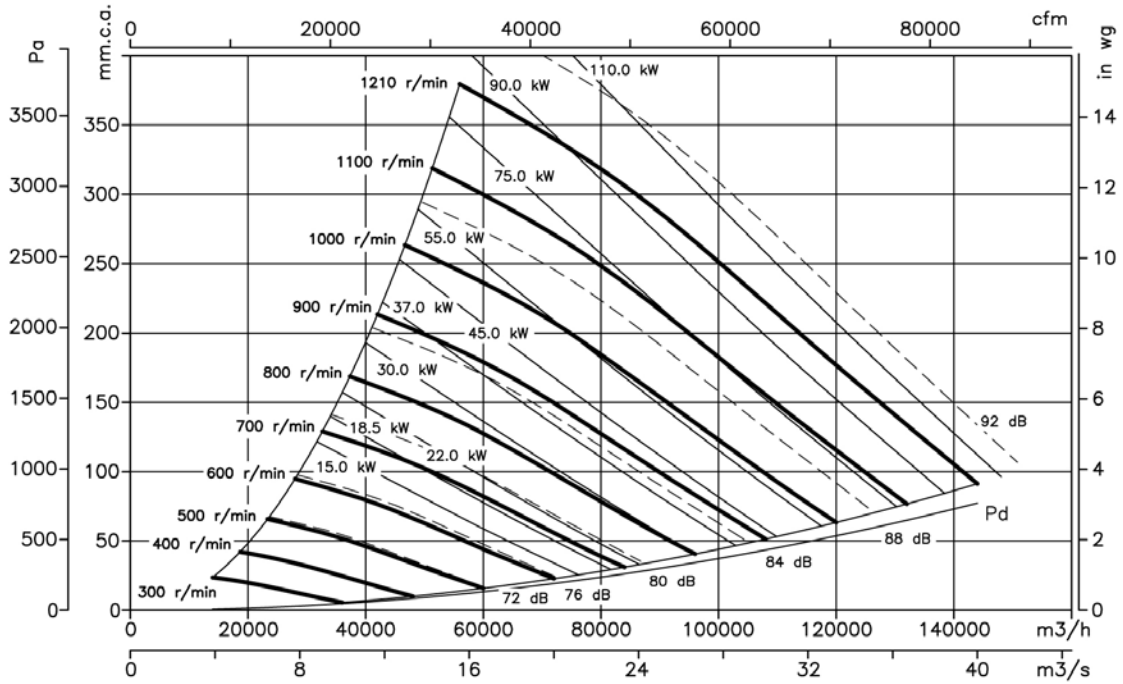

32140

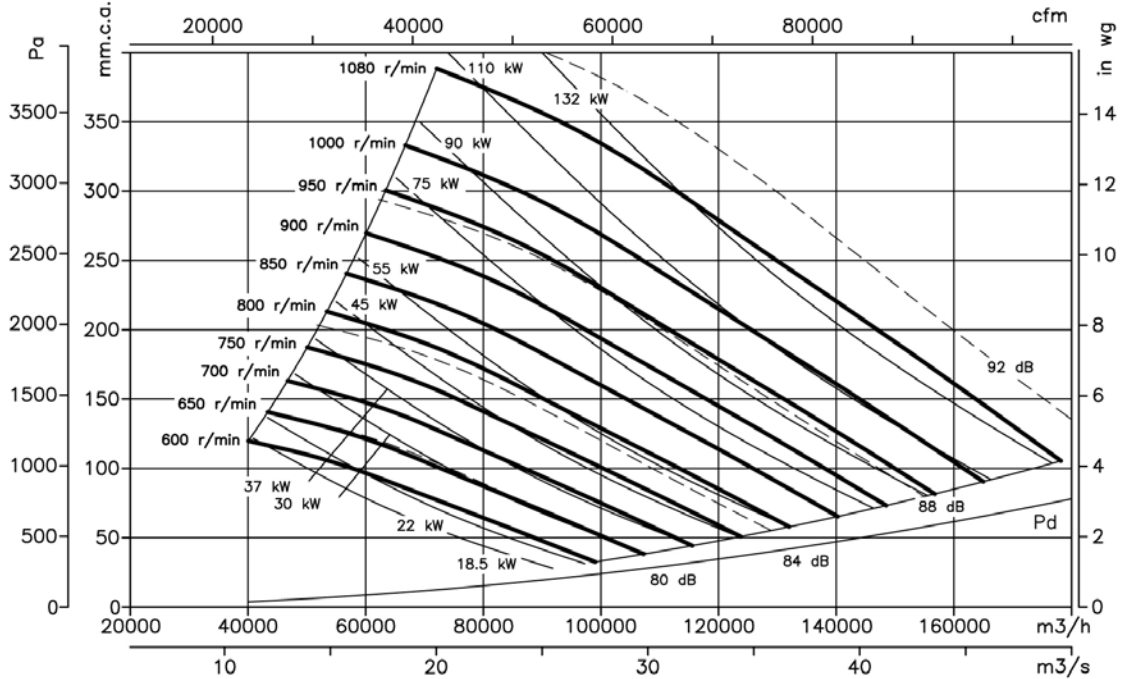

Characteristic Curves

Q = Airflow in m³/h, m³/s and cfm.

Pe= Static pressure in mm.w.c., Pa and in wg.

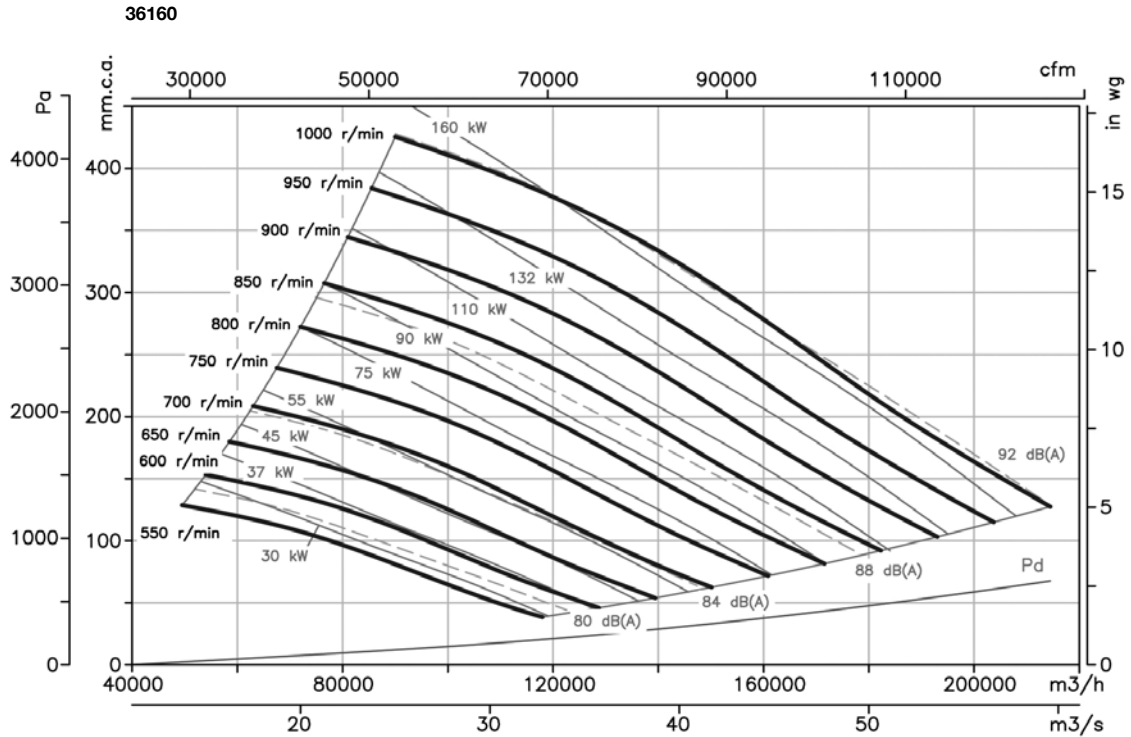

Positions

LG 270 standard supply

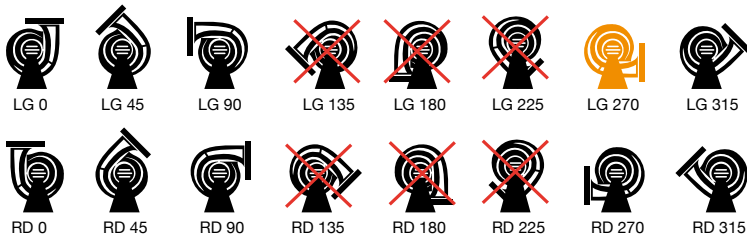

Accessories

See the accessories section.



INT

C2V

RM

AR

RFT

AET

RPA

B

BIC

ACE

CJACUS

S

REG

CMRH

Belt-driven fan with electric motor, pulley and belt kit and standardised protectors in accordance with standard EN-294 and ISO-13852 and 150 mm mineral fibre fireproof plate for horizontal work



External grease fittings to make maintenance easier

Fan:

- Thick sheet steel structure
- Impeller with backward-curved blades made from robust sheet steel
- Transmission set with cast bearings and bracket

Motor:

- Motors with IE-2 efficiency, except for motors with lower powers than 0.75 kW, monophase motors or two-speed motors
- Class F motors with ball bearings, IP55 protection
- Three-phase 230/400V.-50Hz. (up to 5.5CV.) and 400/690V.-50Hz. (power over 5.5CV.)
- Max. air temperature to transport: -20°C.+ 300°C.

Finish:

- Treated with heat-resistant paint

On request:

- Special windings for different voltages
- Heat-resistant steel fan for temperatures up to 400°C
- Version to work in a vertical position

Order code

CMRH — 1856 — X — /R — 7.5

CMRH: Belt-driven fan and 150 mm mineral fibre fireproof plate for horizontal work

Impeller size

Belt-driven fan

Fitted with refrigeration impeller

Power motor (c.v.)

Technical characteristics

Model	Speed (r/min)	Maximum admissible current (A)			Installed Power (kW)	Maximum Airflow (m³/h)	Sound pressure level dB(A)	Approx. weight (Kg)
		230V	400V	690V				
CMRH-1445-X/R-3	1700	8.49	4.90		2.20	9620	79	203
CMRH-1445-X/R-4	1910	11.09	6.40		3.00	10810	81	207
CMRH-1445-X/R-5.5	2120	14.38	8.30		4.00	12000	83	226
CMRH-1650-X/R-4	1530	11.09	6.40		3.00	9910	80	212
CMRH-1650-X/R-5.5	1720	14.38	8.30		4.00	11140	82	231
CMRH-1650-X/R-7.5	1910		11.40	6.60	5.50	12370	84	250
CMRH-1856-X/R-5.5	1365	14.38	8.30		4.00	14210	79	241
CMRH-1856-X/R-7.5	1535		11.40	6.60	5.50	15980	81	260
CMRH-1856-X/R-10	1705		15.10	8.70	7.50	17780	83	273
CMRH-2063-X/R-7.5	1365		11.40	6.60	5.50	22860	82	265
CMRH-2063-X/R-10	1515		15.10	8.70	7.50	25370	84	278
CMRH-2063-X/R-15	1700		21.50	12.40	11.00	28470	86	305
CMRH-2271-X/R-15	1370		21.50	12.40	11.00	32300	87	350
CMRH-2271-X/R-20	1540		28.50	16.50	15.00	36300	90	375
CMRH-2380-X/R-25	1280		35.00	20.20	18.50	43885	83	405
CMRH-2380-X/R-30	1365		41.00	23.70	22.00	46800	85	422

Dimensions in mm

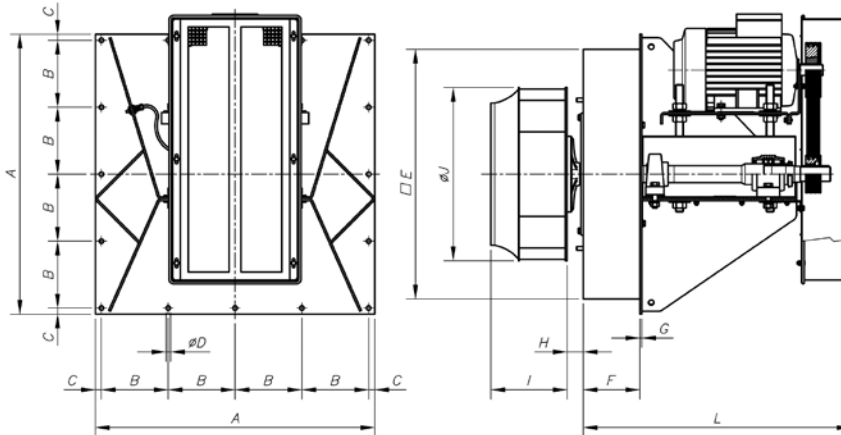

Model	A	B	C	øD	E	F	G	H	I	øJ	L
CMRH-1445-X/R-3	740	177	16	12	660	150	5	43	202	458	706
CMRH-1445-X/R-4	740	177	16	12	660	150	5	43	202	458	706
CMRH-1445-X/R-5'5	740	177	16	12	660	150	5	43	202	458	706
CMRH-1650-X/R-4	740	177	16	12	660	150	5	43	224	508	707
CMRH-1650-X/R-5'5	740	177	16	12	660	150	5	43	224	508	707
CMRH-1650-X/R-7'5	740	177	16	12	660	150	5	43	224	508	707
CMRH-1856-X/R-4	800	192	16	12	720	150	5	43	245.5	573	816
CMRH-1856-X/R-5'5	800	192	16	12	720	150	5	43	245.5	573	816
CMRH-1856-X/R-7'5	800	192	16	12	720	150	5	43	245.5	573	816
CMRH-2063-X/R-7'5	800	192	16	12	720	150	5	43	274	644	816
CMRH-2063-X/R-10	800	192	16	12	720	150	5	43	274	644	816
CMRH-2063-X/R-15	800	192	16	12	720	150	5	43	274	644	816
CMRH-2271-X/R-15	970	232.5	20	14	870	150	5	43	295	719	816
CMRH-2271-X/R-20	970	232.5	20	14	870	150	5	43	295	719	816
CMRH-2380-X/R-25	970	232.5	20	14	870	150	5	53	400	810	920
CMRH-2380-X/R-30	970	232.5	20	14	870	150	5	53	400	810	920

Characteristic Curves

See characteristic curves, CMR-X series.

Accessories

See the accessories section.



INT

C2V

RM

AR

RFT

AET

ARO

VOL

CMSH

Centrifugal medium-pressure fans fitted with impeller with backward-facing blades and 150 mm mineral fibre fireproof plate



Fan:

- Steel sheet structure
- Impeller with backward-curved blades made from sheet steel
- Heat resistant plate made from high-density mineral fibre and high thermal and acoustic insulation capacity



Plate insulated with 150 mm-thick mineral fibre with a high thermal insulation capacity

Motor:

- Single-phase two-speed motors with IE-2 efficiency, except lower powers 0.75 kW
- Class F motors with ball bearings, IP55 protection
- Three-phase 230/400V.-50Hz. (up to 5.5CV.) and 400/690V.-50Hz. (power over 5.5CV.)
- Max. air temperature to transport: -20°C.+ 250°C.

Finish:

- Treated with heat-resistant paint

On request:

- Special windings for different voltages
- Made from stainless steel

Order code



CMSH: Centrifugal medium-pressure fans and 150 mm mineral fibre fireproof plate

Impeller size

Number of motor poles
2=2900 r/min. 50 Hz
4=1400 r/min. 50 Hz
6=900 r/min. 50 Hz

T=Three-phase Power motor (c.v.)

Technical characteristics

Model	Speed (r/min)	Maximum admissible current (A)			Installed Power (kW)	Maximum Airflow (m³/h)	Sound pressure level dB(A)	Approx. weight (Kg)
		230V	400V	690V				
CMSH-831-2T-2	2850	4.33	2.50		1.50	2650	65	27.5
CMSH-935-2T-2	2870	5.80	3.35		1.50	3660	70	35.4
CMSH-1040-4T-1.5	1420	2.67	1.54		1.10	2660	57	31.9
CMSH-1145-4T-1.5	1410	4.49	2.59		1.10	3940	61	54.3
CMSH-1240-4T-1.5	1410	3.29	1.90		1.10	5300	62	53.4
CMSH-1445-4T-2	1420	5.98	3.45		1.50	8450	70	61.0
CMSH-1650-4T-3	1430	8.31	4.80		2.20	10900	71	78.5
CMSH-1856-4T-5.5	1425	13.86	8.00		4.00	17100	77	90.6
CMSH-2063-4T-7.5	1450		11.10	6.40	5.50	19200	77	126.9
CMSH-2063-6T-3	940	9.28	5.36		2.20	13600	66	120.9
CMSH-2271-4T-15	1460		22.00	12.70	11.00	31000	83	170.6
CMSH-2271-4T-20	1460		29.00	16.70	15.00	34600	85	187.6
CMSH-2271-6T-5.5	960	15.14	8.74		4.00	21900	75	151.6
CMSH-2380-4T-30	1460		42.00	24.20	22.00	47600	86	251.1
CMSH-2380-6T-15	970		23.20	13.40	11.00	30900	78	257.1

Acoustic features

Sound power Lw(A) spectrum in dB(A) via frequency band in Hz.

Model	63	125	250	500	1000	2000	4000	8000	Model	63	125	250	500	1000	2000	4000	8000
CMSH-831-2T-2	54	63	68	68	72	71	64	58	CMSH-2063-4T-7,5	66	72	91	86	86	86	83	74
CMSH-935-2T-2	59	68	73	73	77	76	69	63	CMSH-2063-6T-3	58	69	76	77	78	77	71	61
CMSH-1040-4T-1,5	50	56	61	62	65	67	59	53	CMSH-2271-4T-15	73	79	97	96	94	94	91	83
CMSH-1240-4T-1,5	46	59	61	73	69	67	64	56	CMSH-2271-4T-20	75	81	99	98	96	96	93	85
CMSH-1145-4T-1,5	56	62	67	68	71	73	65	59	CMSH-2271-6T-5,5	65	78	79	83	92	86	82	71
CMSH-1445-4T-2	55	65	78	81	79	79	75	65	CMSH-2380-4T-30	76	82	100	99	97	97	94	86
CMSH-1650-4T-3	52	65	79	79	82	80	77	67	CMSH-2380-6T-15	68	81	82	86	95	89	85	74
CMSH-1856-4T-5,5	64	71	88	88	87	87	86	83									

Dimensions in mm

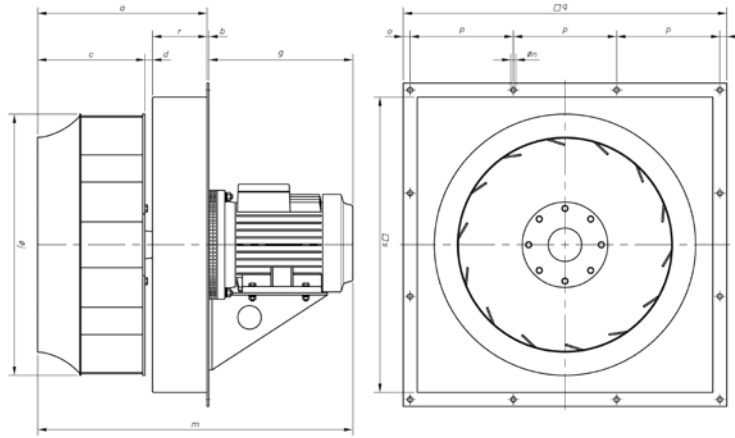

Model	a	b	c	d	g	øj	m	øn	o	p	q	r	s
CMSH-831-2T-2	253.5	3	83	20.5	305	315	561.5	11.5	15	150	480	150	400
CMSH-935-2T-2	265.5	3	93.5	22	305	350	573.5	14	20	188	604	150	495
CMSH-1040-4T-1'5	273.5	3	103.45	20	305	400	581.5	14	15	188	604	150	495
CMSH-1145-4T-1'5	283.5	5	114	19.5	305	450	593.5	14	15	200	630	150	565
CMSH-1240-4T-1'5	356.5	5	184	22.5	305	404	666.5	14	15	200	630	150	565
CMSH-1445-4T-2	397.5	5	220	27.5	305	458	707.5	14	15	200	630	150	565
CMSH-1650-4T-3	428	5	248	30	335	508	768	14	16	236	740	150	673
CMSH-1856-4T-5'5	449.5	5	277.5	22	335	573	789.5	14	16	236	740	150	673
CMSH-2063-4T-7'5	470	5	299	21	396	644	871	14	19	284	890	150	813
CMSH-2063-6T-3	470	5	299	21	358	644	833	14	19	284	890	150	813
CMSH-2271-4T-15	500	5	330	20	514	719	1019	14	19	284	890	150	813
CMSH-2271-4T-20	500	5	330	20	514	719	1019	14	19	284	890	150	813
CMSH-2271-6T-5'5	466	5	295	21	396	719	867	14	19	284	890	150	813
CMSH-2380-4T-30	538.5	5	366	22.5	588	808	1131.5	14	19	248	1030	150	953
CMSH-2380-6T-15	538.5	5	366	22.5	514	808	1057.5	14	19	248	1030	150	953

Characteristic Curves

Q = Airflow in m³/h, m³/s and cfm.

Pe = Static pressure in mm.w.c., Pa and in wg.

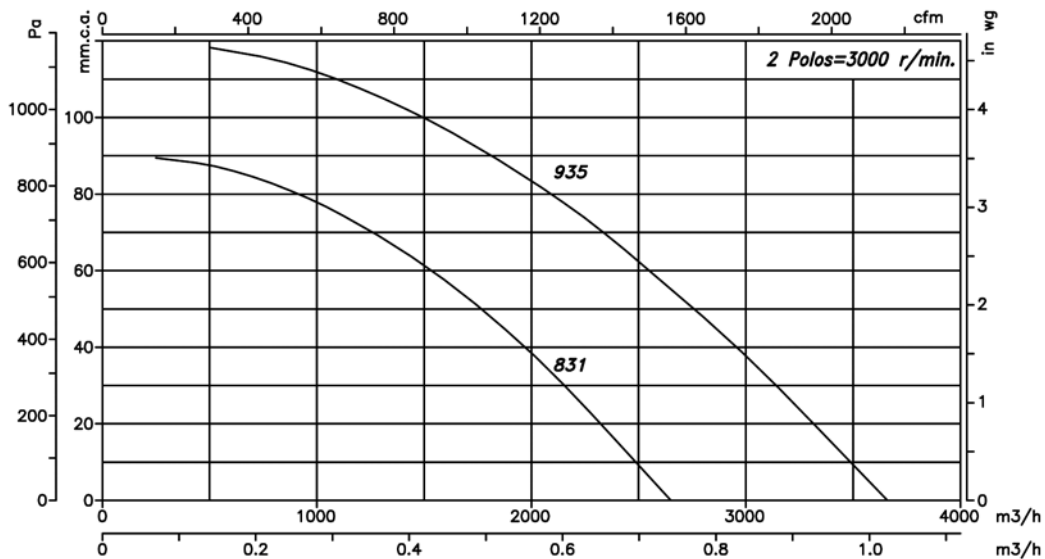

Characteristic Curves

Q = Airflow in m³/h, m³/s and cfm.

Pe = Static pressure in mm.w.c., Pa and in wg.

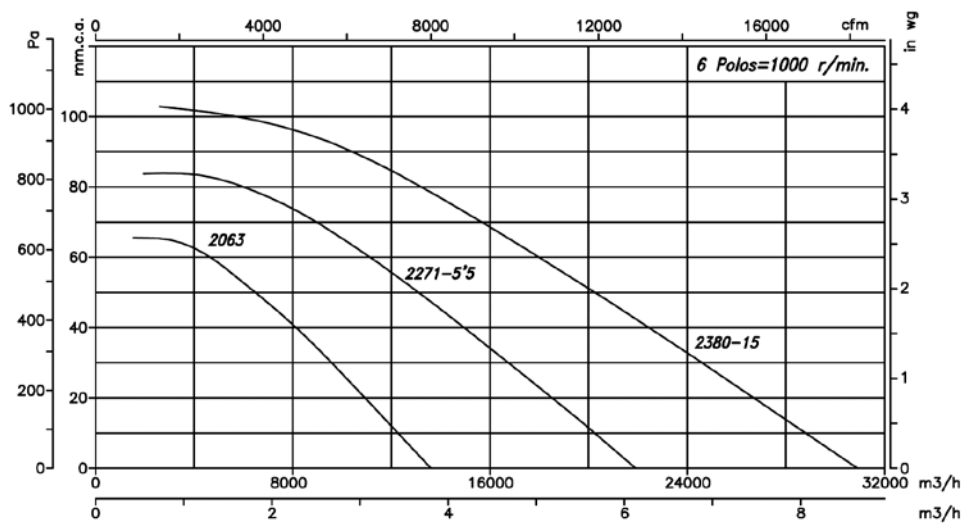
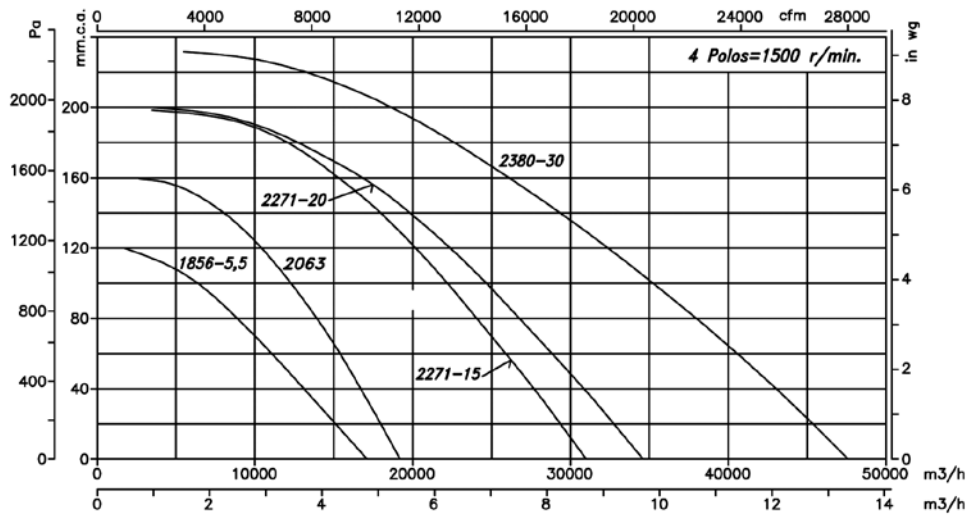
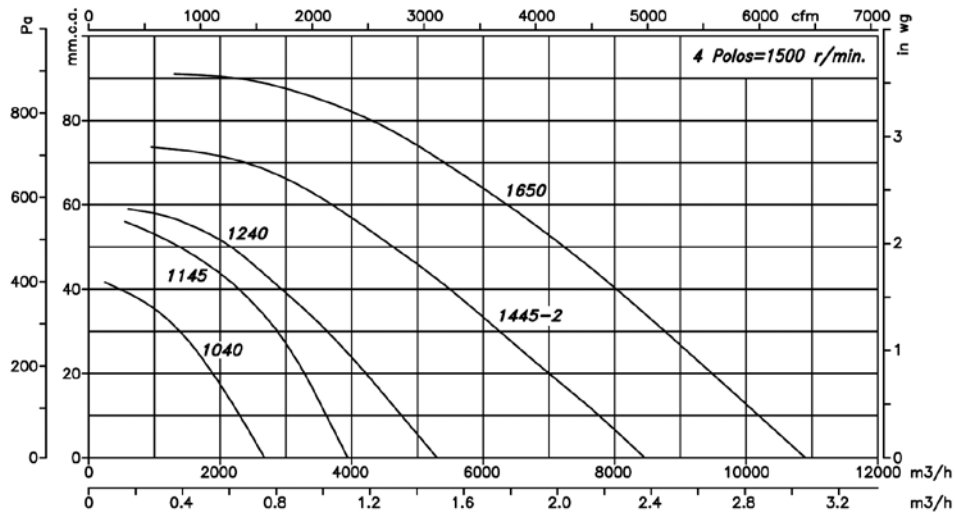

Accessories

See the accessories section.



INT

C2V

RM

AR

RFT

AET

ARO

CMPH

Centrifugal medium-pressure fans fitted with multi-blade impeller and 150 mm mineral fibre fireproof plate



Fan:

- Steel sheet structure
- Impeller with forward-facing blades made from galvanised sheet steel
- Heat resistant plate made from high-density mineral fibre and high thermal and acoustic insulation capacity



Plate insulated with 150 mm-thick mineral fibre with a high thermal insulation capacity

Motor:

- Motors with IE-2 efficiency, except for motors with lower powers than 0.75 kW, monophase motors or two-speed motors
- Class F motors with ball bearings, IP55 protection
- Three-phase 230/400V.-50Hz. (up to 5.5CV) and 400/690V.-50Hz. (power over 5.5CV)
- Max. air temperature to transport: -20°C.+ 250°C.

Finish:

- Treated with heat-resistant paint

On request:

- Special windings for different voltages
- Made from stainless steel

Order code

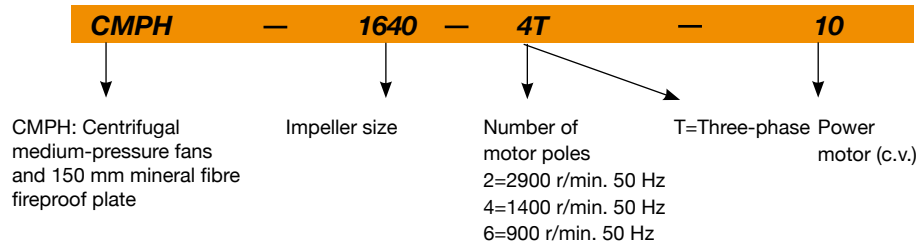

Technical characteristics

Model	Speed (r/min)	Maximum admissible current (A)			Installed Power (kW)	Maximum Airflow (m³/h)	Sound pressure level dB(A)	Approx. weight (Kg)
		230V	400V	690V				
CMPH-512-2T-0.25	2850	1.21	0.70		0.18	475	62	7.0
CMPH-512-4T-0.07	1440	0.55	0.32		0.05	255	55	6.5
CMPH-514-2T-0.25	2850	1.21	0.70		0.18	800	65	11.2
CMPH-514-4T-0.10	2850	1.21	0.70		0.08	565	58	11.2
CMPH-616-2T-0.5	2740	1.73	1.00		0.37	1380	69	13.3
CMPH-616-4T-0.14	1400	0.65	0.37		0.10	850	61	10.8
CMPH-620-2T-0.5	2740	1.73	1.00		0.37	765	68	15.4
CMPH-620-4T-0.14	1375	0.69	0.40		0.10	810	61	12.9
CMPH-718-2T-1	2855	3.00	1.73		0.75	1485	70	18.3
CMPH-718-4T-0.33	1410	1.32	0.76		0.25	1280	63	14.9
CMPH-820-2T-1.5	2845	4.16	2.40		1.10	1950	73	20.4
CMPH-820-4T-0.33	1350	1.32	0.76		0.25	1670	66	15.3
CMPH-922-2T-1.5	2845	4.16	2.40		1.10	1650	70	24.1
CMPH-922-2T-2	2860	5.63	3.25		1.50	2010	71	27.1
CMPH-922-2T-3	2880	7.97	4.60		2.20	2600	74	29.9
CMPH-922-4T-0.75	1395	2.51	1.45		0.55	2450	66	22.2

Technical characteristics

Model	Speed (r/min)	Maximum admissible current (A)			Installed Power (kW)	Maximum Airflow (m³/h)	Sound pressure level dB(A)	Approx. weight (Kg)
		230V	400V	690V				
CMPH-1025-2T-3	2880	7.97	4.60		2.20	2100	73	30.5
CMPH-1025-2T-4	2895	10.57	6.10		3.00	2830	77	37.8
CMPH-1025-4T-1.5	1410	4.59	2.65		1.10	3400	70	27.1
CMPH-1128-2T-4	2895	10.57	6.10		3.00	2220	77	42.9
CMPH-1128-2T-5.5	2900	13.34	7.70		4.00	3210	81	49.9
CMPH-1128-4T-3	1420	8.49	4.90		2.20	5000	74	43.9
CMPH-1128-6T-1	910	3.91	2.26		0.75	3300	60	35.9
CMPH-1231-4T-3	1420	8.49	4.90		2.20	4740	73	44.3
CMPH-1231-4T-4	1420	11.09	6.40		3.00	5910	75	46.3
CMPH-1231-4T-5.5	1440	14.38	8.30		4.00	6850	77	51.3
CMPH-1231-6T-2	940	7.48	4.30		1.50	5115	64	43.3
CMPH-1435-4T-4	1420	11.09	6.40		3.00	5560	76	47.6
CMPH-1435-4T-5.5	1440	14.38	8.30		4.00	6260	78	52.6
CMPH-1435-4T-7.5	1455		11.40	6.60	5.50	7210	80	66.6
CMPH-1435-6T-3	930	9.32	5.36		2.20	6400	66	49.6
CMPH-1640-4T-5.5	1440	14.38	8.30		4.00	7500	77	65.3
CMPH-1640-4T-7.5	1455		11.40	6.60	5.50	8035	80	79.3
CMPH-1640-4T-10	1455		15.10	8.70	7.50	9710	82	90.3
CMPH-1640-6T-3	930	9.32	5.36		2.20	8100	71	62.3
CMPH-1845-4T-7.5	1455		11.40	6.60	5.50	8965	82	89.9
CMPH-1845-4T-10	1455		15.10	8.70	7.50	10350	85	100.9
CMPH-1845-6T-3	930	9.32	5.36		2.20	8330	77	72.9
CMPH-2050-4T-10	1455		15.10	8.70	7.50	9000	83	112.0
CMPH-2050-4T-12.5	1450		17.80	10.30	9.20	10730	85	115.0
CMPH-2050-4T-15	1460		21.50	12.40	11.00	12525	87	131.0
CMPH-2050-4T-20	1455		28.50	16.50	15.00	19000	89	150.0
CMPH-2050-6T-5.5	940	15.60	8.95		4.00	11000	79	124.0
CMPH-2563-6T-15	970		23.00	13.30	11.00	16500	86	180.3
CMPH-2563-6T-25	985		36.00	20.80	18.50	28000	87	266.3

Acoustic features

Sound power Lw(A) spectrum in dB(A) via frequency band in Hz.																	
Model	63	125	250	500	1000	2000	4000	8000	Model	63	125	250	500	1000	2000	4000	8000
CMPH-512-2T-0.25	37	47	58	65	69	66	64	57	CMPH-1231-4T-3	51	60	71	78	82	80	78	71
CMPH-512-4T-0.07	30	40	51	58	62	59	57	50	CMPH-1231-4T-4	53	62	73	80	84	82	80	73
CMPH-514-2T-0.25	40	50	61	68	72	69	67	60	CMPH-1231-4T-5.5	55	64	75	82	86	84	82	75
CMPH-514-4T-0.10	33	43	54	61	65	62	60	53	CMPH-1231-6T-2	42	51	62	69	73	71	69	62
CMPH-616-2T-0.5	44	54	65	72	76	73	71	64	CMPH-1435-4T-4	54	63	74	81	85	83	81	74
CMPH-616-4T-0.14	36	46	57	64	68	65	63	56	CMPH-1435-4T-5.5	56	65	76	83	87	85	83	76
CMPH-620-2T-0.5	43	53	64	71	75	72	70	63	CMPH-1435-4T-7.5	58	67	78	85	89	87	85	78
CMPH-620-4T-0.14	36	46	57	64	68	65	63	56	CMPH-1435-6T-3	44	53	64	71	75	73	71	64
CMPH-718-2T-1	45	55	66	73	77	74	72	65	CMPH-1640-4T-5.5	55	64	75	82	86	84	82	75
CMPH-718-4T-0.33	38	48	59	66	70	67	65	58	CMPH-1640-4T-7.5	58	67	78	85	89	87	85	78
CMPH-820-2T-1.5	48	58	69	76	80	77	75	68	CMPH-1640-4T-10	60	69	80	87	91	89	87	80
CMPH-820-4T-0.33	41	51	62	69	73	70	68	61	CMPH-1640-6T-3	49	58	69	76	80	78	76	69
CMPH-922-2T-1.5	45	55	66	73	77	74	72	65	CMPH-1845-4T-7.5	61	71	82	89	93	91	89	81
CMPH-922-2T-2	46	56	67	74	78	75	73	66	CMPH-1845-4T-10	64	74	85	92	96	94	92	84
CMPH-922-2T-3	49	59	70	77	81	78	76	69	CMPH-1845-6T-3	56	66	77	84	88	86	84	76
CMPH-922-4T-0.75	41	51	62	69	73	70	68	61	CMPH-2050-4T-10	62	72	83	90	94	92	90	82
CMPH-1025-2T-3	48	58	69	76	80	77	75	68	CMPH-2050-4T-12.5	64	74	85	92	96	94	92	84
CMPH-1025-2T-4	52	62	73	80	84	81	79	72	CMPH-2050-4T-15	66	76	87	94	98	96	94	86
CMPH-1025-4T-1.5	45	55	66	73	77	74	72	65	CMPH-2050-4T-20	68	78	89	96	100	98	96	88
CMPH-1128-2T-4	52	62	73	80	84	81	79	72	CMPH-2050-6T-5.5	58	68	79	86	90	88	86	78
CMPH-1128-2T-5.5	56	66	77	84	88	85	83	76	CMPH-2563-6T-15	67	77	88	95	99	96	94	87
CMPH-1128-4T-3	49	59	70	77	81	78	76	69	CMPH-2563-6T-25	68	78	89	96	100	97	95	88
CMPH-1128-6T-1	35	45	56	63	67	64	62	55									

Dimensions in mm

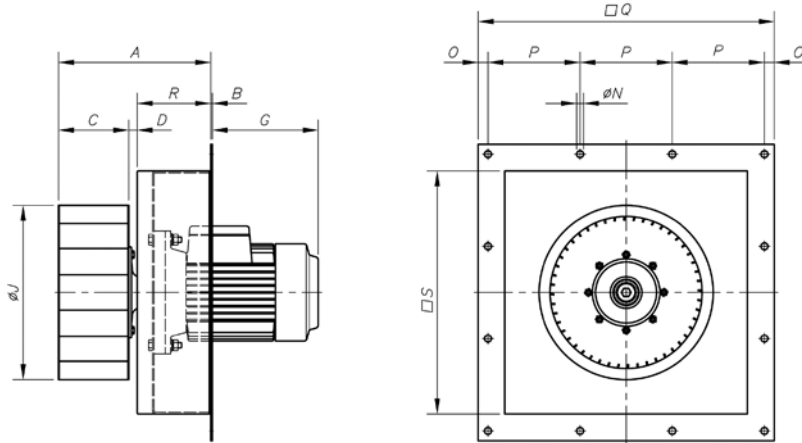

Model	A	B	C	D	G Max.	øJ	øN	O	P	Q	R	S
CMPH-512	108	3	50.5	6.5	159	120	7	12	97	315	50	260
CMPH-514	158.5	3	51.5	7	109	140	7	10	125	395	100	340
CMPH-616	169.5	3	62	6.5	155	160	7	10	125	395	100	340
CMPH-718	179.5	3	74	5	180	180	7	10	125	395	100	340
CMPH-620-2T-0.5	167	3	62	5	155	200	7	10	125	395	100	340
CMPH-620-4T-0.14	167	3	62	9	155	200	7	10	125	395	100	340
CMPH-820	187	3	82	5	180	200	7	10	125	395	100	340
CMPH-922	246.5	3	92	5	186	225	11.5	15	150	480	150	400
CMPH-1025	256.5	3	102	5	210	250	11.5	15	150	480	150	400
CMPH-1128	279.5	3	114	15	239	280	14	20	188	604	150	495
CMPH-1231	293.5	3	128	15	239	315	14	20	188	604	150	495
CMPH-1435	310.5	3	143	17.5	277	355	14	20	188	604	150	495
CMPH-1640	332	5	163	17.5	277	400	14	15	200	630	150	565
CMPH-1845-4T-7.5	358.5	5	180	17.5	277	454	14	16	236	740	150	673
CMPH-1845-4T-10	358.5	5	180	17.5	277	454	14	16	236	740	150	673
CMPH-1845-6T-3	352.5	5	180	23.5	239	454	14	16	236	740	150	673
CMPH-2050	376.5	5	204	23.5	388	500	14	16	236	740	150	673
CMPH-2563-6T-15	425	5	254	22.5	555	630	14	19	284	890	150	813
CMPH-2563-6T-25	443.5	5	254	39.5	555	630	14	19	284	890	150	813

Characteristic Curves

See characteristic curves, CMP series.

Accessories

See the accessories section.



INT

C2V

RM

AR

RFT

AET

CMAT

Centrifugal single-inlet, medium-pressure fans with casing and straight-blade impeller made from cast aluminium to transport dust and solids



Fan:

- Casing made from cast aluminium
- Cast aluminium straight-blade impeller for models 324 to 531 and sheet steel for models 540 to 545

Motor:

- Motors with IE-2 efficiency, except for motors with lower powers than 0.75 kW, monophase motors or two-speed motors
- Class F motors with ball bearings, IP55 protection
- Three-phase 230/400V.-50Hz
- Max. air temperature to transport: -20°C.+ 120°C.

Finish:

- Anticorrosive finish in polyester resin, polymerised at 190°C, after alkaline degreasing and phosphate-free pre-treatment.

On request:

- Special windings for different voltages
- Fan designed to transport air up to 250°C
- ATEX certification, Category 2

Option of different impeller positions

Order code

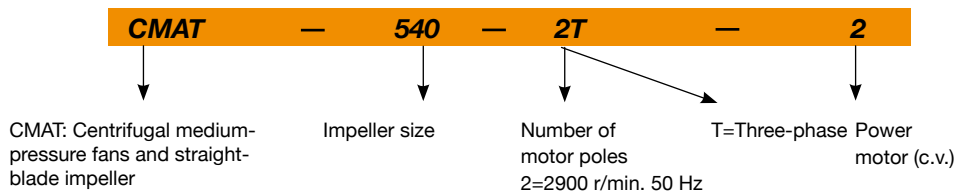

Technical characteristics

Model	Speed (r/min)	Maximum admissible current (A)		Installed Power (kW)	Maximum Airflow (m³/h)	Sound pressure level dB(A)	Approx. weight (Kg)
		230V	400V				
CMAT-324-2T	2850	1.21	0.70	0.18	300	70	8.5
CMAT-325-2T	2810	1.64	0.95	0.25	450	73	11.1
CMAT-426-2T	2830	1.92	1.11	0.37	650	75	12.0
CMAT-527-2T	2830	1.92	1.11	0.37	900	80	13.4
CMAT-528-2T	2855	3.00	1.73	0.75	1400	80	19.8
CMAT-531-2T	2850	4.40	2.50	1.10	1800	84	24.0
CMAT-540-2T-2	2860	5.65	3.25	1.50	2080	80	38.5
CMAT-540-2T-3	2880	7.90	4.55	2.20	2800	82	41.0
CMAT-545-2T-4	2890	10.60	6.10	3.00	3115	80	56.0

Acoustic features

Sound power Lw(A) spectrum in dB(A) via frequency band in Hz.

Model	63 125 250 500 1000 2000 4000 8000								Model	63 125 250 500 1000 2000 4000 8000							
	324	42	48	72	79	76	69	60		52	531	51	67	90	92	89	83
325	47	54	76	80	80	75	65	56	540-2	55	76	91	86	87	83	76	68
426	42	54	78	85	77	71	63	58	540-3	57	81	89	88	92	89	83	75
527	47	61	84	90	82	75	67	61	545	62	81	87	86	87	89	82	74
528	49	64	89	85	84	79	72	65									

Dimensions in mm

CMAT-324...531

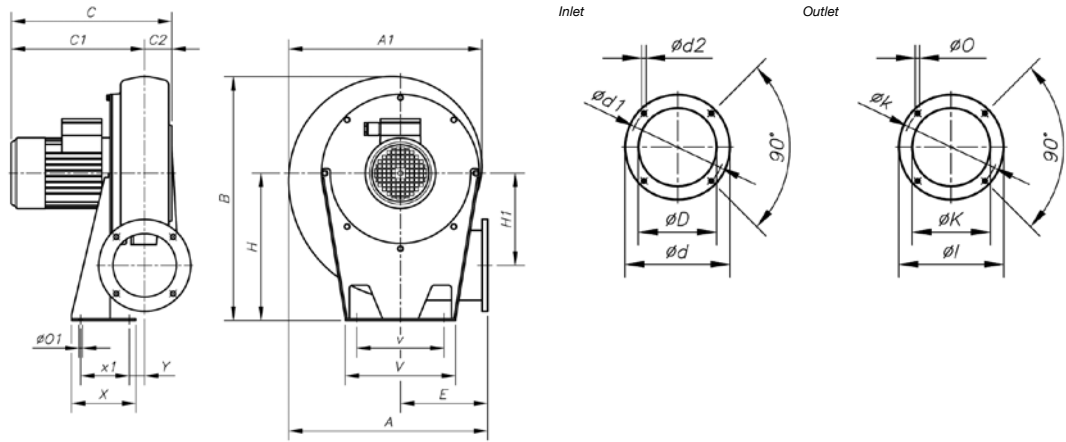

Model	A	A1	B	C	C1	C2	øD	ød	ød1	ød2	E	H	H1	øI	øK	øk	øO	øO1	V	v	X	x1	Y
CMAT-324	311	302	356	268	226	38	80	130	112	M5	145	205	145	108	62	90	7	9	173	125	90	60	20
CMAT-325	335	328	399	271	244	40	94	140	122	M6	155	235	152	120	80	102	7	9	180	145	110	80	20
CMAT-426	354	344	412	291	255	40	117	155	132	M6	165	240	163	170	90	119	7	13	210	160	105	65	26
CMAT-527	371	361	440	295	261	42	125	170	147	M6	168	260	170	155	100	129	7	13	220	170	120	80	20
CMAT-528	401	395	488	337	304	48	135	190	162	M6	178	290	177	190	130	160	11	13	230	180	140	100	20
CMAT-531	440	434	537	340	315	50	160	215	180	M6	193	320	200	200	140	175	11	13	240	190	160	120	21

CMAT-540-545

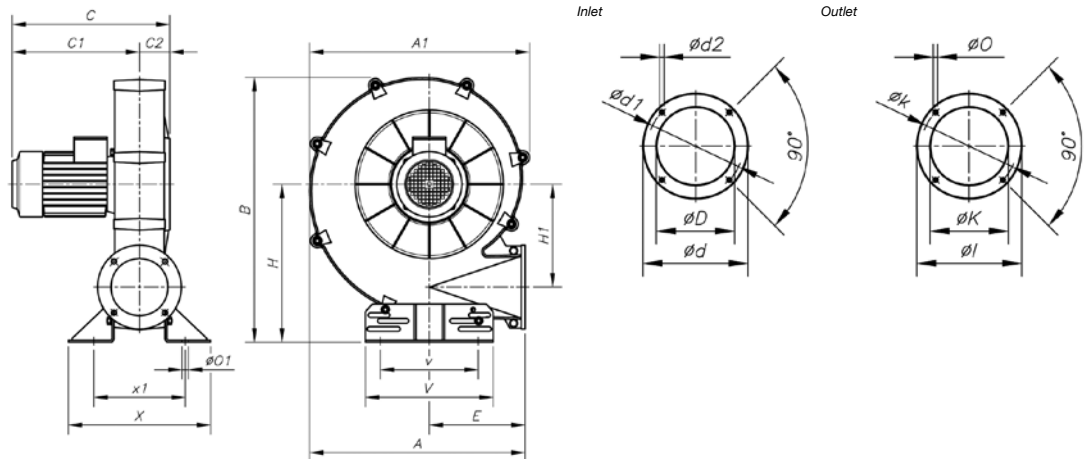

Model	A	A1	B	C	C1	C2	øD	ød	ød1	ød2	E	H	H1	øI	øK	øk	øO	øO1	V	v	X	x1	Y
CMAT-540	567	580	695	415	320	80	170	240	205	M10	252	415	270	220	150	190	13	11	336	218	374	240	-
CMAT-545	651	646	776	484	368	115	180	255	220	M10	290	450	309	250	175	220	13	13	336	238	392	292	-

Characteristic Curves

Q = Airflow in m³/h, m³/s and cfm.

Pe = Static pressure in mm.w.c., Pa and in wg.

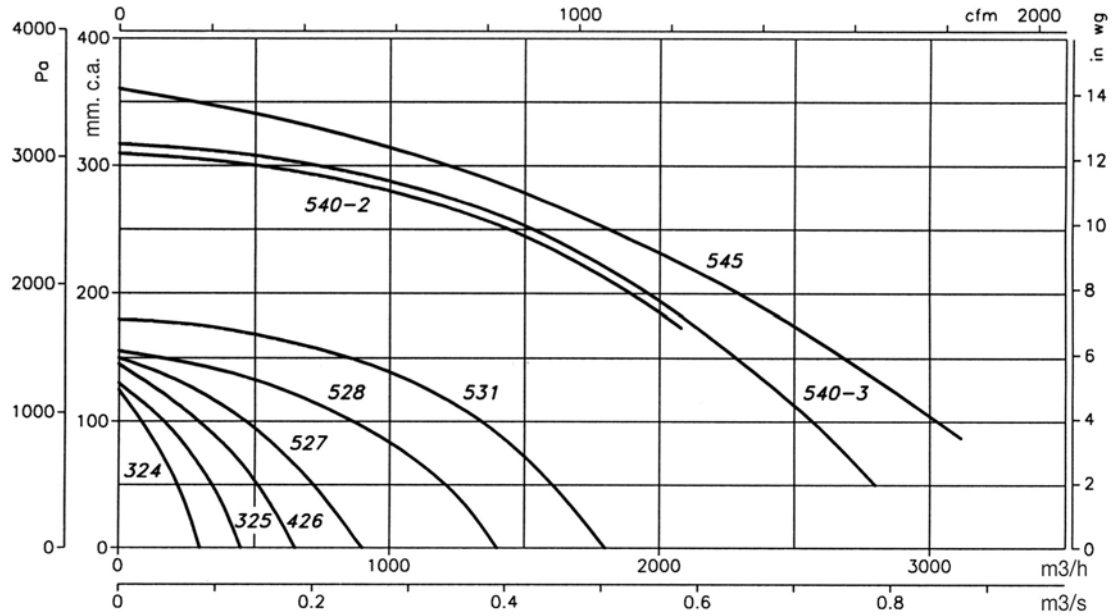

Positions

LG 270 standard supply
 LG 180 position on request and with special
 fixing measurements.



Accessories

See the accessories section.



CMT

Centrifugal single-inlet, medium-pressure fans with casing and straight-blade impeller made from sheet steel to transport dust and solids



Robust radial impeller

Fan:

- Steel sheet casing
- Sheet steel straight-blade impeller

Motor:

- Motors with IE-2 efficiency, except for motors with lower powers than 0.75 kW, monophase motors or two-speed motors
- Class F motors with ball bearings, IP55 protection
- Three-phase 230/400V.-50Hz. (up to 5.5CV) and 400/690V.-50Hz. (power over 5.5CV)
- Max. air temperature to transport: -20°C.+ 120°C

Finish:

- Anticorrosive finish in polyester resin, polymerised at 190°C, after alkaline degreasing and phosphate-free pre-treatment.

On request:

- Special windings for different voltages
- Fan designed to transport air up to 250°C
- ATEX certification, Category 2

Order code

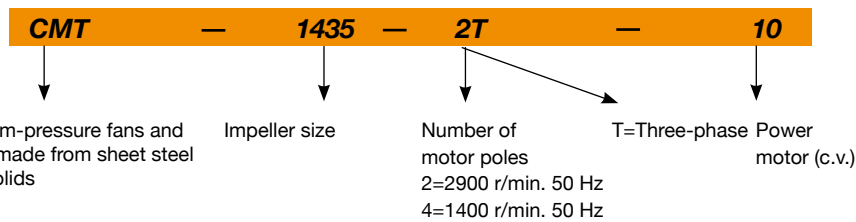

Technical characteristics

Model	Speed (r/min)	Maximum admissible current (A)			Installed Power (kW)	Maximum Airflow (m³/h)	Sound pressure level dB(A)	Approx. weight (Kg)
		230V	400V	690V				
CMT-922-2T	2900	4.16	2.40		1.10	2180	71	22.0
CMT-922-4T	1480	2.51	1.45		0.55	1080	66	20.0
CMT-1025-2T	2900	5.63	3.25		1.50	2850	74	31.0
CMT-1025-4T	1470	2.51	1.45		0.55	1390	70	27.0
CMT-1128-2T	2900	7.97	4.60		2.20	4500	76	37.0
CMT-1128-4T	1460	2.51	1.45		0.55	2250	72	30.0
CMT-1231-2T-4	2900	10.57	6.10		3.00	5220	78	53.0
CMT-1231-2T-5.5	2900	13.34	7.70		4.00	6300	79	70.0
CMT-1231-4T	1470	4.59	2.65		1.10	3000	73	43.0
CMT-1435-2T-7.5	2930		10.50	6.10	5.50	7800	85	86.0
CMT-1435-2T-10	2900		13.90	8.00	7.50	8260	87	95.0
CMT-1435-4T	1470	8.49	4.90		2.20	4175	76	62.0
CMT-1640-2T-7.5	2950		10.50	6.10	5.50	5600	88	96.0
CMT-1640-2T-10	2950		13.90	8.00	7.50	9600	90	105.0
CMT-1640-4T	1450	8.49	4.90		2.20	4800	77	78.0
CMT-1845-2T-10	2900		13.90	8.00	7.50	5000	89	155.0
CMT-1845-2T-15	2900		20.00	11.50	11.00	10500	91	183.0
CMT-1845-2T-20	2900		26.50	15.30	15.00	13000	94	194.0
CMT-1845-4T	1470	14.38	8.30		4.00	8200	80	144.0
CMT-2050-2T-25	2900		32.00	18.50	18.50	8500	98	225.0
CMT-2050-2T-30	2900		39.00	22.50	22.00	13600	99	275.0
CMT-2050-4T	1430		11.40	6.60	5.50	11300	85	160.0

Acoustic features

Sound power Lw(A) spectrum in dB(A) via frequency band in Hz.

Model	63	125	250	500	1000	2000	4000	8000	Model	63	125	250	500	1000	2000	4000	8000
922-2	45	61	76	76	77	74	72	63	1435-4	53	68	84	83	85	81	79	71
922-4	40	56	71	71	72	69	67	58	1640-2-7.5	65	80	96	95	97	93	91	83
1025-2	48	64	79	79	80	77	75	66	1640-2-10	67	82	98	97	99	95	93	85
1025-4	44	60	75	75	76	73	71	62	1640-4	54	69	85	84	86	82	80	72
1128-2	50	66	81	81	82	79	77	68	1845-2-10	68	83	98	98	99	96	94	85
1128-4	46	62	77	77	78	75	73	64	1845-2-15	70	85	100	100	101	98	96	87
1231-2-4	55	70	86	85	87	83	81	73	1845-2-20	73	88	103	103	104	101	99	90
1231-2-5.5	56	71	87	86	88	84	82	74	1845-4	59	74	89	89	90	87	85	76
1231-4	50	65	81	80	82	78	76	68	2050-2-25	77	92	107	107	108	105	103	94
1435-2-7.5	62	77	93	92	94	90	88	80	2050-2-30	78	93	108	108	109	106	104	95
1435-2-10	64	79	95	94	96	92	90	82	2050-4	64	79	94	94	95	92	90	81

Dimensions in mm

CMT-922...1231

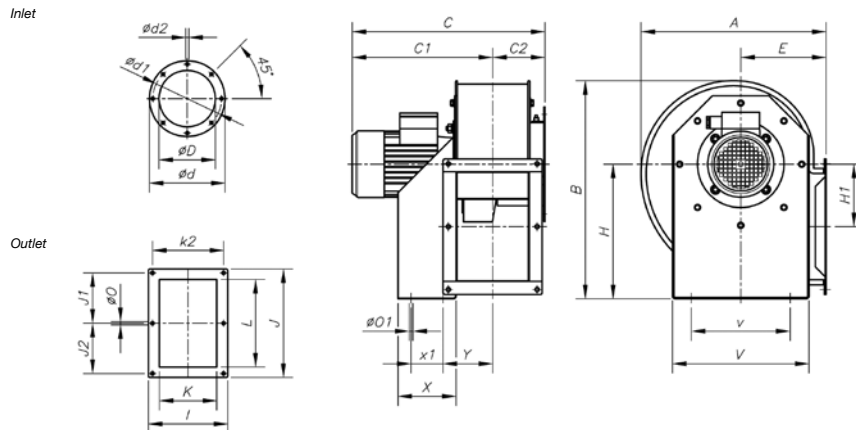

Model	A	B	C	C1	C2	ϕD	ϕd	$\phi d1$	$\phi d2$	E	H	H1	I	J	J1	K	k2	L	ϕO	$\phi O1$	V	v	X	x1	Y
CMT-922	388.5	455	416	309	107	170	244	210	9.5	180	280	134	204	282.5	128	140	180	215	9.5	10.5	290	220	114	50	105
CMT-1025-2T	427	503	490	369.5	120.5	190	264	230	9.5	197	310	144	229	312.5	145	165	205	250	9.5	12.5	315	228	134	74	115.5
CMT-1025-4T	427	503	442	321.5	120.5	190	264	230	9.5	197	310	144	229	312.5	145	165	205	250	9.5	12.5	315	228	134	74	115.5
CMT-1128-2T	472	553	505	377	128	210	284	249	9.5	216	340	152	244	364	170	180	220	296.5	9.5	12.5	348	245	144	95	122.5
CMT-1128-4T	472	553	457	329	128	210	284	249	9.5	216	340	152	244	364	170	180	220	296.5	9.5	12.5	348	245	144	95	122.5
CMT-1231-2T-4	526	630	555	417	138	240	305	275	9.5	238	390	179.5	264	382.5	180	200	240	320	11.5	13	382	322	183	140	126
CMT-1231-2T-5.5	526	630	578	440	138	240	305	275	9.5	238	390	179.5	264	382.5	180	200	240	320	11.5	13	382	322	183	140	126
CMT-1231-4T	526	630	525	387	138	240	305	275	9.5	238	390	179.5	264	382.5	180	200	240	320	11.5	13	382	322	183	140	126

CMT-1435...2050

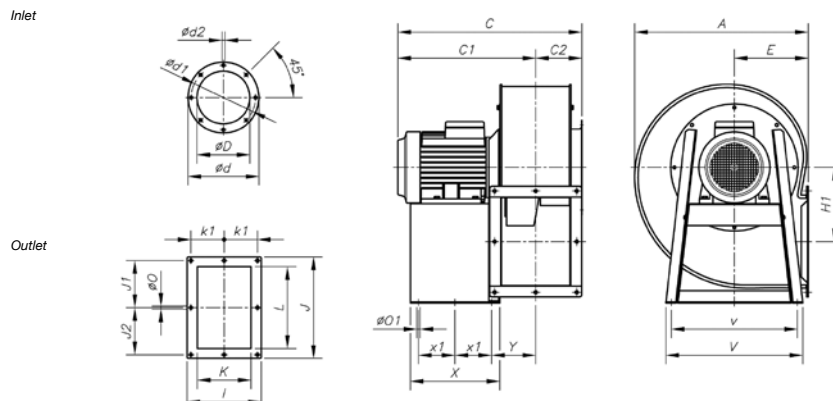

Model	A	B	C	C1	C2	ϕD	ϕd	$\phi d1$	$\phi d2$	E	H	H1	I	J	J1	K	k1	L	ϕO	$\phi O1$	V	v	X	x1	Y
CMT-1435-2T	573.5	715	649	492	157	270	344	310	9.5	250	445	242.5	292	342.5	159	228	133	280	11.5	12	456	420	333	136.5	150
CMT-1435-4T	573.5	715	588	431	157	270	344	310	9.5	250	445	242.5	292	342.5	159	228	133	280	11.5	12	456	420	333	136.5	150
CMT-1640-2T	634	799	673	504	169	270	344	310	9.5	2270	495	271	336	404	185	250	150	321	11.5	12	500	460	327	133.5	162.5
CMT-1640-4T	634	799	612	443	169	270	344	310	9.5	270	495	271	336	404	185	250	150	321	11.5	12	500	460	327	133.5	162.5
CMT-1845-2T-10	711	901	712	521	191	350	434	395	9.5	302	560	305	370	444	202	284	164	361	11.5	12	538	502	340	140	179.5
CMT-1845-2T-15	711	901	817	626	191	350	434	395	9.5	302	560	305	370	444	202	284	164	361	11.5	12	538	502	420	180	179.5
CMT-1845-2T-20	711	901	817	626	191	350	434	395	9.5	302	560	305	370	444	202	284	164	361	11.5	12	538	502	420	180	179.5
CMT-1845-4T	711	901	674	483	191	350	434	395	9.5	302	560	305	370	444	205	284	164	361	11.5	12	538	502	340	140	179.5
CMT-2050-2T-25	797	987	855	642.5	212.5	375	480	450	11	345	610	313	411	544	250	315	182.5	451	11.5	12	653	615	435	188	196
CMT-2050-2T-30	797	987	979	766.5	212.5	375	480	450	11	345	610	313	411	544	250	315	182.5	451	11.5	12	653	615	435	188	196
CMT-2050-4T	797	987	750	537.5	212.5	375	480	450	11	345	610	313	411	544	250	315	182.5	451	11.5	12	653	615	435	188	196

Characteristic Curves

Q = Airflow in m³/h, m³/s and cfm.

Pe= Static pressure in mm.w.c., Pa and in wg.

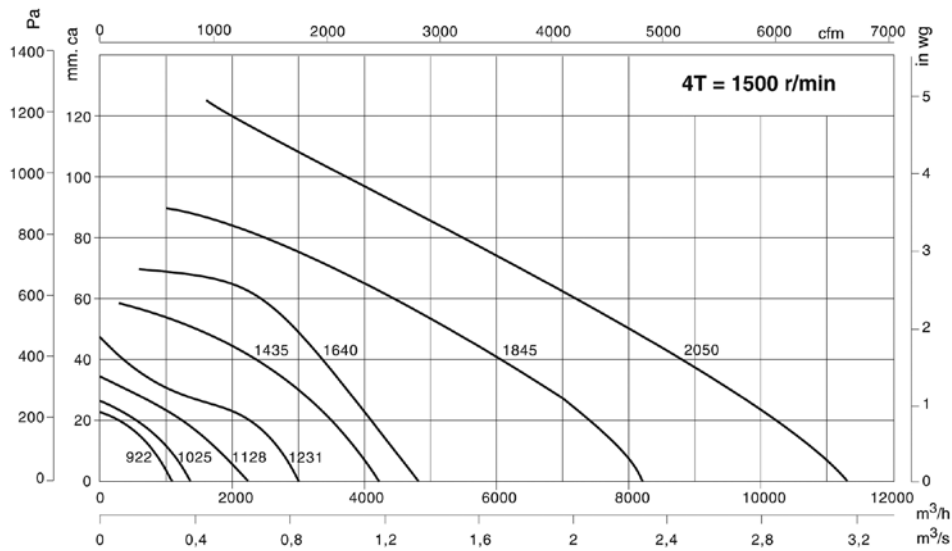
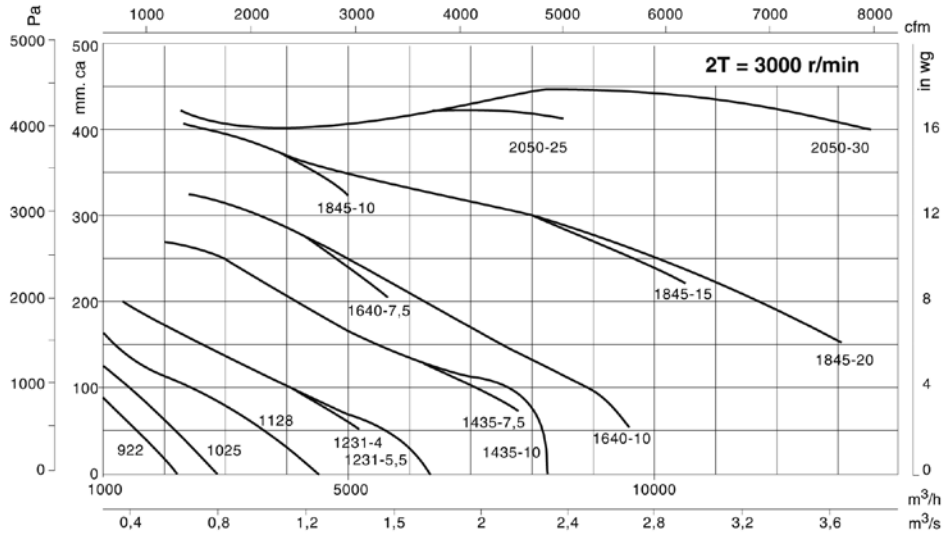

Positions

LG 270 standard supply

LG 180 and RD 180 positions on request and with special fixing measures.

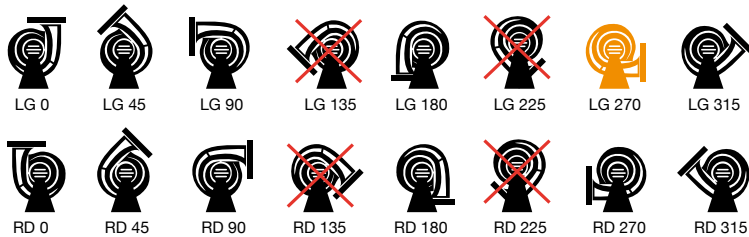

Accessories

See the accessories section.



CAST

Centrifugal single-inlet, high-pressure fans with casing and straight-blade impeller made from sheet steel to transport dust and solids



Robust motor bedplate

Fan:

- Steel sheet casing
- Sheet steel straight-blade impeller

Motor:

- Motors with IE-2 efficiency, except for motors with lower powers than 0.75 kW, monophase motors or two-speed motors
- Class F motors with ball bearings, IP55 protection
- Three-phase 230/400V.-50Hz. (up to 5.5CV.) and 400/690V.-50Hz. (power over 5.5CV.)
- Max. air temperature to transport: -20°C.+ 120°C

Finish:

- Anticorrosive finish in polyester resin, polymerised at 190°C, after alkaline degreasing and phosphate-free pre-treatment.

On request:

- Special windings for different voltages
- Fan designed to transport air up to 250°C
- ATEX certification, Category 2

Order code

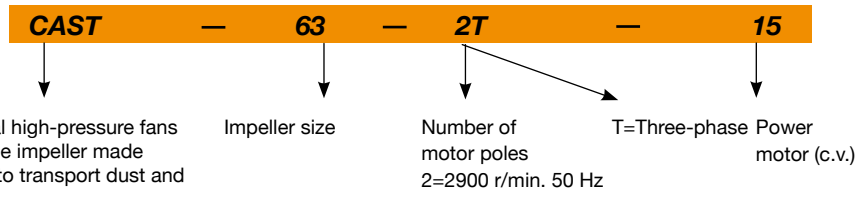

Technical characteristics

Model	Speed (r/min)	Maximum admissible current (A)		Installed Power (kW)	Maximum Airflow (m³/h)	Sound pressure level dB(A)	Approx. weight (Kg)
		400V	690V				
CAST-50-2T-5.5	2895	7.60	4.40	4.0	2100	85	73
CAST-50-2T-7.5	2855	10.50	6.10	5.5	2700	86	87
CAST-50-2T-10	2855	13.90	8.00	7.5	3780	87	92
CAST-56-2T-10	2855	13.90	8.00	7.5	2700	89	130
CAST-56-2T-15	2915	20.50	11.80	11.0	4260	90	191
CAST-56-2T-20	2900	27.00	15.60	15.0	6000	90	202
CAST-63-2T-15	2915	20.50	11.80	11.0	3000	92	224
CAST-63-2T-20	2900	27.00	15.60	15.0	4260	93	235
CAST-63-2T-25	2915	32.50	18.80	18.5	6000	93	245
CAST-71-2T-30	2925	39.00	22.50	22.0	4800	95	297
CAST-71-2T-40	2945	53.00	30.60	30.0	6720	96	351

Dimensions in mm

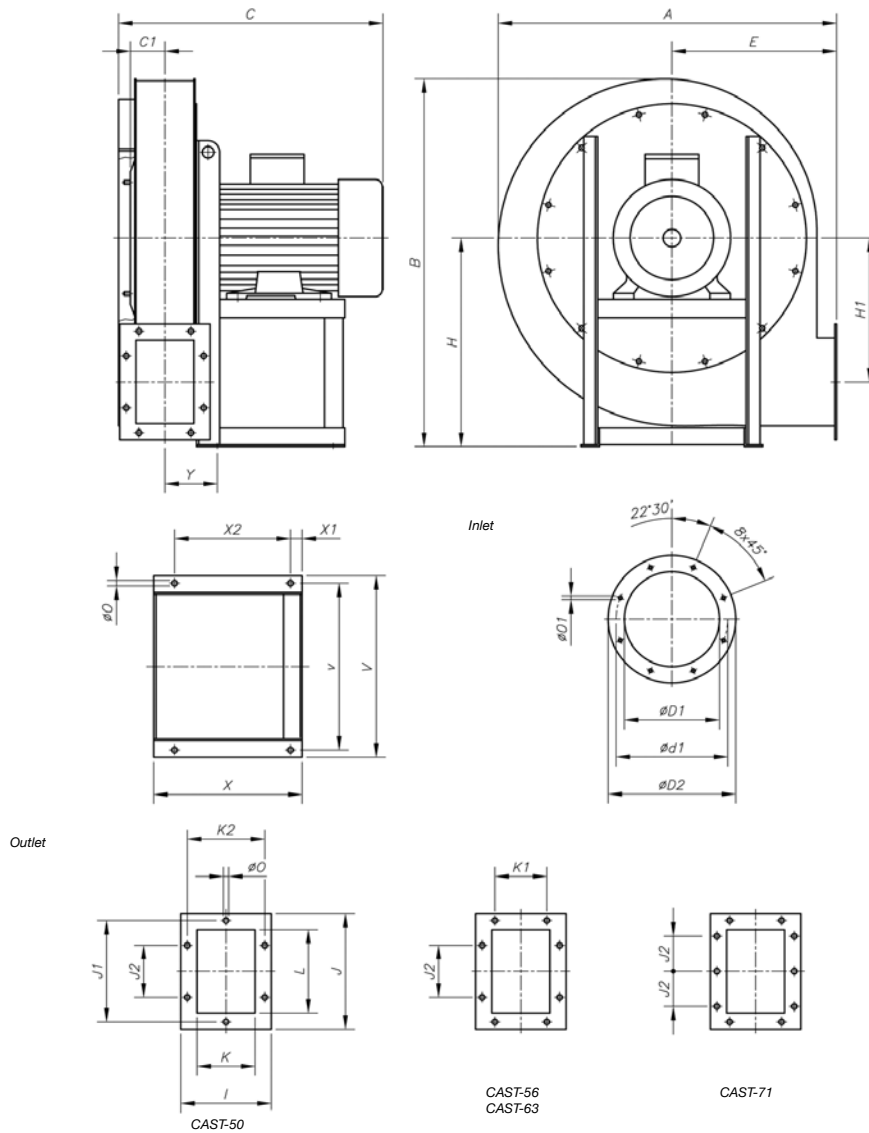

Model	Fan													Outlet						Inlet									
	A	B	C	C1	E	H	H1	Ø0	v	V	X	X1	X2	Y	I	J	J1	J2	K	K1	K2	L	Ø0	n°	Ød1	ØD1	ØD2	ØO1	n°
	drills																												
CAST-50-2T-5'5	730	795	510	75	355	450	310	12	300	332	260	25	200	70	195	250	219	112	125	-	167	180	11'5	6	241	205	275	11'5	8
CAST-50-2T-7'5	730	795	570	75	355	450	310	12	360	392	320	25	250	70	195	250	219	112	125	-	167	180	11'5	6	241	205	275	11'5	8
CAST-50-2T-10	730	795	570	75	355	450	310	12	360	392	320	25	250	70	195	250	219	112	125	-	167	180	11'5	6	241	205	275	11'5	8
CAST-56-2T-10	825	895	595	86	400	500	350	12	360	392	320	25	250	79	210	270	241	112	140	112	182	200	11'5	8	265	229	299	11'5	8
CAST-56-2T-12'5	825	895	595	86	400	500	350	12	360	392	320	25	250	79	210	270	241	112	140	112	182	200	11'5	8	265	229	299	11'5	8
CAST-56-2T-15	825	895	730	86	400	500	350	14	400	440	425	30	340	79	210	270	241	112	140	112	182	200	11'5	8	265	229	299	11'5	8
CAST-56-2T-20	825	895	730	86	400	500	350	14	400	440	425	30	340	79	210	270	241	112	140	112	182	200	11'5	8	265	229	299	11'5	8
CAST-63-2T-15	895	990	750	100	425	560	390	14	400	440	425	30	340	89	230	294	265	112	160	112	200	224	11'5	8	292	255	325	11'5	8
CAST-63-2T-20	895	990	750	100	425	560	390	14	400	440	425	30	340	89	230	294	265	112	160	112	200	224	11'5	8	292	255	325	11'5	8
CAST-63-2T-30	895	990	750	100	425	560	390	14	400	440	425	30	340	89	230	294	265	112	160	112	200	224	11'5	8	292	255	325	11'5	8
CAST-71-2T-30	1005	1115	780	110	475	630	435	14	450	500	470	35	370	100	250	320	292	112	180	112	219	250	11'5	10	332	286	366	11'5	8
CAST-71-2T-40	1005	1115	855	110	475	630	435	16	510	700	500	40	385	100	250	320	292	112	180	112	219	250	11'5	10	332	286	366	11'5	8

Characteristic Curves

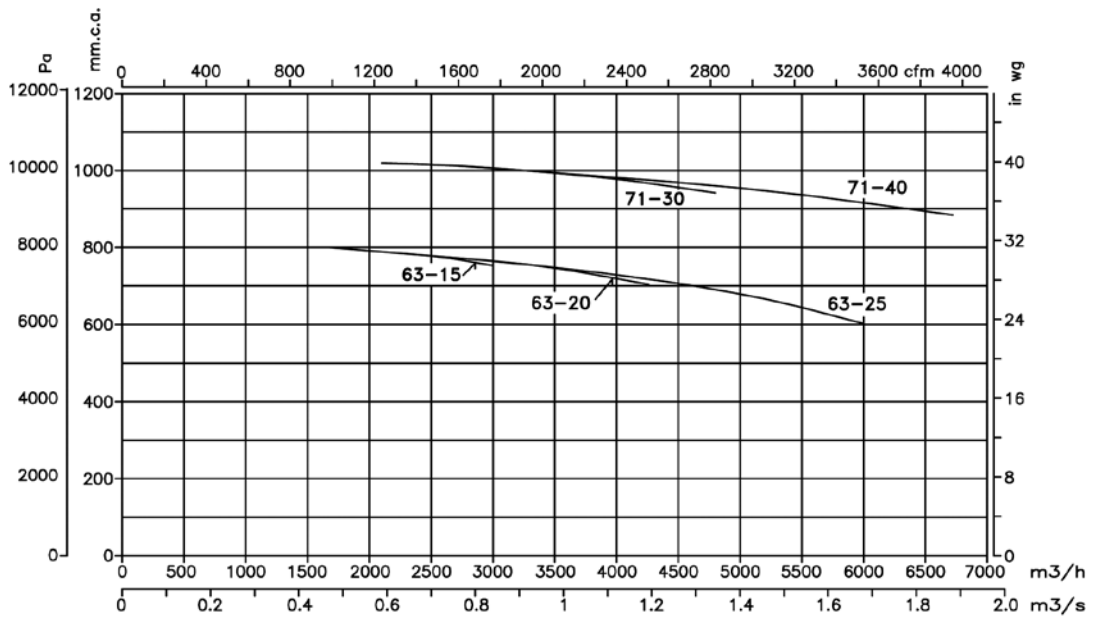
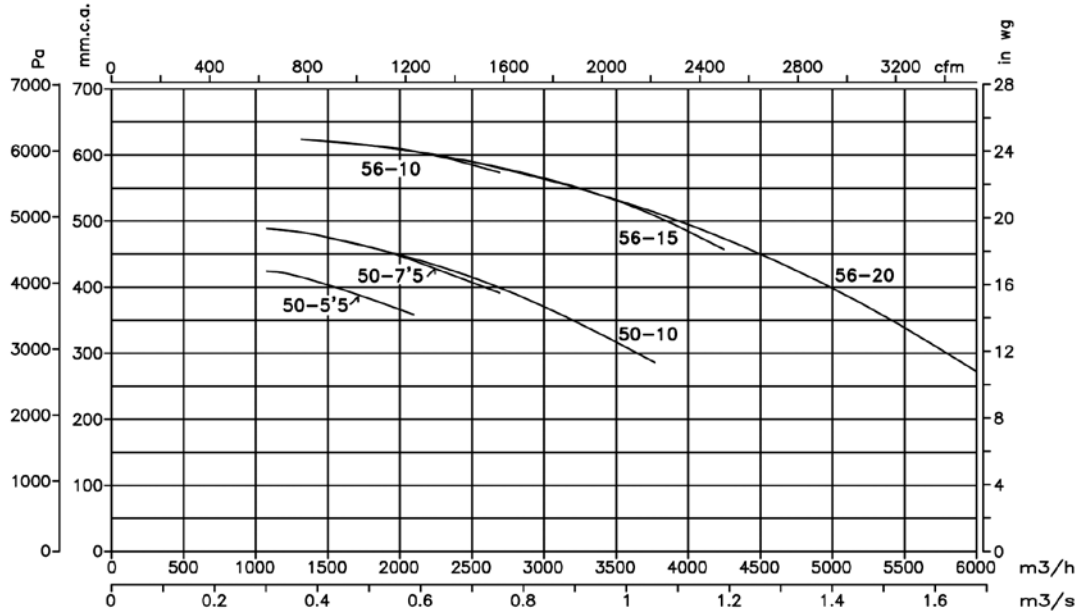

Positions

LG 270 standard supply
 LG 180 position on request and with
 special fixing measurements.



Supplied on request
 RD 180 position with special fixing
 measurements.



Accessories

See the accessories section.



IN-LINE ACCESSORIES



198

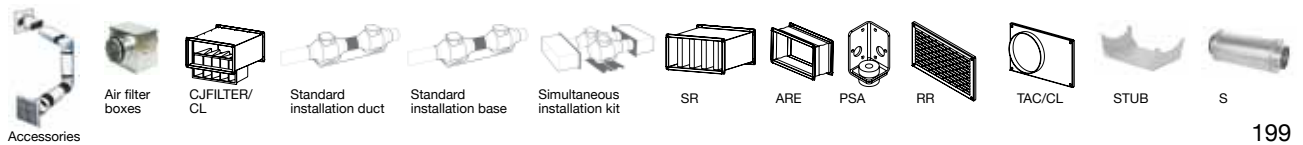

199

CENTRIFUGAL ACCESSORIES

<p>INT</p> <p>On/Off safety switches in accordance with Standard UNE-EN 60204-1.</p> <p>200</p>	<p>IAT</p> <p>On/Off safety switch for 200°C/2h and 400°C/2h</p> <p>200</p>	<p>CABLE BOX</p> <p>Electrical cable and connection box kit 400°C/2h</p> <p>200</p>	<p>C2V</p> <p>Switch for two-speed motors.</p> <p>200</p>	<p>RM</p> <p>Electronic speed controllers</p> <p>200</p>
<p>AR</p> <p>Smooth starters for three-phase motors.</p> <p>201</p>	<p>RFT RFM</p> <p>Frequency converters for 230V three-phase motors.</p> <p>201</p>	<p>ELECTRICAL PANELS</p> <p>Electrical panels</p> <p>202</p>	<p>PL</p> <p>Backdraught shutters</p> <p>204</p>	<p>RPA</p> <p>Protection guard for inlet of centrifugal fans.</p> <p>204</p>
<p>B</p> <p>Coupling flange for centrifugal fans.</p> <p>205</p>	<p>BD</p> <p>Double, elastic coupling flange for centrifugal fans.</p> <p>206</p>	<p>BIC</p> <p>Flange to change from rectangular to circular for centrifugal fans.</p> <p>206</p>	<p>PSB</p> <p>Set of support stand for low-pressure centrifugal fans</p> <p>207</p>	<p>SM</p> <p>Motor mounting bracket and belt tensing device for low-pressure centrifugal fans</p> <p>207</p>

<p>VIS</p>  <p>Outlet hood with protection guard.</p> <p>207</p>	<p>ACE</p>  <p>Elastic coupling to absorb vibrations</p> <p>208</p>	<p>REG</p>  <p>Record of regulation manual</p> <p>208</p>	<p>TEJ</p>  <p>Outside covers.</p> <p>208</p>	<p>CM</p>  <p>Motor cover for outside work.</p> <p>209</p>
<p>TAC</p>  <p>Circular coupling plate.</p> <p>209</p>	<p>VOL</p>  <p>Casing for fans that re-circulate air in ovens</p> <p>209</p>	<p>ARO</p>  <p>Inlet for fans that re-circulate air in ovens</p> <p>209</p>	<p>CJACUS</p>  <p>Soundproof boxes for centrifugal fans</p> <p>209</p>	<p>S</p>  <p>Silencers to fit to inlet or outlet</p> <p>210</p>
<p>MOTORS</p> <p>Three-phase asynchronous motors</p>  <p>212</p>	<p>OUTPUT OPENINGS FOR HOUSES</p>  <p>215</p>	<p>AIR INTAKES FOR HOUSES</p>  <p>215</p>	<p>INTELLIGENT SENSORS</p>  <p>216</p>	<p>KITS SOBREPRESIÓN</p>  <p>93</p>

Electronic speed controllers



For single-phase fans, possibility of installing on a surface or built-in

Model	Input voltage	Protection	Max. Intensity (A)
RM-00	230 V-50/60 Hz	IP-44	0,5
RM-01	230 V-50/60 Hz	IP-44	1
RM-02	230 V-50/60 Hz	IP-44	2

DUO



Speed-change and stop switch, for small fans with two-speed motor

Model	Input voltage	Max. Intensity (A)
DUO	230 V-50/60 Hz	16

Brushless motor speed control



Model	Output voltage	Resistance value
MTP	0-10VDC	10KΩ

Capture openings



Made from plastic to open onto duct

Model	Ext. measurements	Duct
BC-135x235	135x235mm	100mm
BC-140x340	140x340mm	100mm
BC-240x240	240x240mm	150mm

Outlet



Made from plastic to install on the exterior

Model	External measurements
SA-140x140	140x140mm
SA-240x240	240x240mm

Inlet/Outlet



Made from plastic with diffuser

Model	For duct	Colour
BA-100/B	100mm	White
BI-100/B	100mm	White

Input and output kits



Formed by 2 grilles and a flexible tube

Model	Duct	Air flow
KIT-120	120mm	100cm ²
KIT-160	160mm	100cm ²
KIT-200	200mm	100cm ²

Rectangular grilles



Made from plastic to adapt to rectangular hole

Model	Ext. measurements	For hole with
R-140 x 140	140 x 140 mm	102 x 102 mm
R-189 x 189	189 x 189 mm	150 x 150 mm
R-240 x 140	240 x 140 mm	202 x 102 mm
R-340 x 140	340 x 140 mm	308 x 108 mm

Circular grilles



Made from plastic with universal spring system to adapt to circular hole

Model	Ext. measurements	For hole with
RC-100/B	106 mm	40 to 80 mm
RC-125/B	155 mm	80 to 125 mm
RC-150/B	175 mm	125 to 160 mm
RC-200/B	235 mm	165 to 220 mm
RC-250/B	270 mm	220 to 260 mm

NEOLINEO-series protection grilles



Protects against contact with the impeller and objects from entering

Model	Applies to models	Model	Applies to models
G 100	NEOLINEO-100	G 200	NEOLINEO-200
G 125	NEOLINEO-125	G 250	NEOLINEO-250
G 150	NEOLINEO-150	G 315	NEOLINEO-315
G 160	NEOLINEO-160		

Backdraught shutters



Made from plastic that is adapted directly to the wall on which the fan is mounted

Model	External measurements
PL-140x140	140x140mm
PL-180x180	180x180mm
PL-240x240	240x240mm
PL-340x340	340x340mm
PL-440x440	440x440mm

SV-series protection grilles



Protects against contact with the impeller and objects from entering

Model	Applies to models
RAI-125	SV-125
RAI-150	SV-150
RAI-200	SV-200
RAI-250	SV-250
RAI-350	SV-350
RAI-400	SV-400

Standard installation base



NEOLINEO adaptation plate between two fans

Model	Applies to models
SF 500	NEOLINEO-100.125.150.160.200
SF 700	NEOLINEO-250.315

Simultaneous installation kit



Set of parts for simultaneous installation of two NEOLINEO fans

Model	Applies to models	Model	Applies to models
PF100	NEOLINEO-100	PF160	NEOLINEO-160
PF125	NEOLINEO-125	PF200	NEOLINEO-200
PF150	NEOLINEO-150	PF250	NEOLINEO-250

Standard installation duct



NEOLINEO pipe connecting two fans

Model	Applies to models	Model	Applies to models
C100	NEOLINEO-100	C200	NEOLINEO-200
C125	NEOLINEO-125	C250	NEOLINEO-250
C150	NEOLINEO-150	C315	NEOLINEO-315
C160	NEOLINEO-160		

IN-LINE ACCESSORIES

Accessories



Easy to install for mounting in localised inlet systems

Model	Features:
TUB-100	Duct with diameter of 100 mm and length of 1 m
UN-100	Joint between duct and accessories
COD-100	90° elbow with diameter of 100 mm
BRIDA-100	Duct fastening clamps
REDU-100-125	Reduction of pipe to different diameters
TUB-125	Duct with diameter of 125 mm and length of 1 m
UN-125	Joint between duct and accessories
COD-125	90° elbow with diameter of 125 mm
BRIDA-125	Duct fastening clamps
REDU-125-100	Reduction of pipe to different diameters

One-way hatches



To fit in circular ducts

Model	Applies to models	Model	Applies to models
S 100	NEOLINEO-100	S 200	NEOLINEO-200
S 125	NEOLINEO-125	S 250	NEOLINEO-250
S 150	NEOLINEO-150	S 315	NEOLINEO-315
S 160	NEOLINEO-160		

ARE

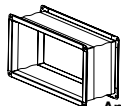

Elastic rectangular connection

Model	Applies to models	Model	Applies to models
ARE-200	CL-200	ARE-315	CL-315
ARE-225	CL-225	ARE-355	CL-355
ARE-250	CL-250	ARE-400	CL-400
ARE-280	CL-280	ARE-450	CL-450

SR



Rectangular silencers

Model	Applies to models	Model	Applies to models
SR-200	CL-200	SR-315	CL-315
SR-225	CL-225	SR-355	CL-355
SR-250	CL-250	SR-400	CL-400
SR-280	CL-280	SR-450	CL-450

S



Silencers to fit to inlet or outlet

Features:

- Circular silencers to fit to inlet or outlet on in-line fans
- Silencers fitted with a neck to attach circular ducts.

Model	Ød1	Ød2	L	M	Acoustic noise reduction							
					63	125	250	500	1000	2000	4000	8000
S-125	125	225	600	720	1.1	2.9	8.8	19.4	27.2	34.1	27.2	13.4
S-160	160	260	600	720	1	2.9	7.2	16.5	23.4	29.6	20.3	9.2
S-200	200	300	600	720	0.95	2.9	7	14.6	20.3	25.8	15.6	6.8
S-250	250	355	600	720	0.2	2.1	7.2	12.5	18.8	23	10.3	5.15
S-315	315	415	600	720	0.2	2.1	7.2	10.3	15	20	7	3.9
S-355	355	450	700	820	3.6	4.2	6.5	13.2	14.2	4	7.9	7.2



Air filter boxes



Rectangular filter boxes for circular ducts, fitted with G-3 filters

Model	G-3 filter box for the following duct	Model	G-3 filter box for the following duct
CJFILTER-100	100mm	CJFILTER-250	250mm
CJFILTER-125	125mm	CJFILTER-315	315mm
CJFILTER-160	160mm	CJFILTER-355	355mm
CJFILTER-200	200mm	CJFILTER-400	400mm

Electric batteries



Adapted to the outlet

Model	Electrical battery for the following duct
BE-100	100 mm, 0.4 kW 230 V
BE-125	125 mm, 1.2 kW 230 V
BE-160	160 mm, 2.4 kW 230 V
BE-200	200 mm, 5 kW 400 V
BE-250	250 mm, 6 kW 400 V
BE-315	315 mm, 7.5 kW 400 V
BE-355	355 mm, 9 kW 400 V
BE-400	400 mm, 9 kW 400 V

Butterfly valves



To fit in circular ducts

Model	Butterfly valves for	Model	Butterfly valves for
V-100	100mm	V-250	250mm
V-125	125mm	V-315	315mm
V-160	160mm	V-355	355mm
V-200	200mm	V-400	400mm

STUB



Fan base

Model	Applies to models
STUB-200	TUB
STUB-225	TUB
STUB-250	TUB

RR

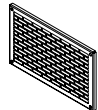

Protection grille for inlet or outlet

Model	Applies to models	Model	Applies to models
RR-200	CL-200	RR-315	CL-315
RR-225	CL-225	RR-355	CL-355
RR-250	CL-250	RR-400	CL-400
RR-280	CL-280	RR-450	CL-450

CJFILTER/CL

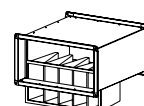

Rectangular air filter boxes

Model	Applies to models	Model	Applies to models
CJFILTER/CL-200	CL-200	CJFILTER/CL-315	CL-315
CJFILTER/CL-225	CL-225	CJFILTER/CL-355	CL-355
CJFILTER/CL-250	CL-250	CJFILTER/CL-400	CL-400
CJFILTER/CL-280	CL-280	CJFILTER/CL-450	CL-450

TAC/CL

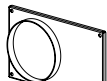

Circular coupling plate.

Model	Applies to models	Model	Applies to models
TAC/CL-200	CL-200	TAC/CL-315	CL-315
TAC/CL-225	CL-225	TAC/CL-355	CL-355
TAC/CL-250	CL-250	TAC/CL-400	CL-400
TAC/CL-280	CL-280	TAC/CL-450	CL-450

PSA



Ceiling base

Model	Applies to models
PSA-200	CL-200, CL-225, CL-250, CL-280, CL-315, CL-355, CL-400, CL-450



INT

On/off safety switches in accordance with Standard UNE-EN 60204-1.

Features:

- Switch to be placed beside the fan, so that mains current can be cut without handling the fan
- IP65 protection
- For three-phase or two-speed fans, use 6-pole switch
- For single-phase fans, use a 3-pole switch

Model	Current (A)	(kW)	Cable input (mm)	Model	Current (A)	(kW)	Cable input (mm)
INT-CA 10/3CA	20	5.5	19	INT-CA 10/6CA	20	5.5	19
INT-KG 10/3CA	20	5.5	23	INT-KG 10/6CA	20	5.5	23
INT-KG 20/3CA	25	7.5	29	INT-KG 20/6CA	25	7.5	29
INT-KG 32/3CA	32	11	29	INT-KG 32/6CA	32	11	29
INT-KG 41/3CA	40	15	37.5	INT-KG 41/6CA	40	15	37.5
INT-KG 64/3CA	63	22	37.5	INT-KG 64/6CA	63	22	37.5
INT-KG 80/3CA	80	30	37.5	INT-KG 80/6CA	80	30	37.5
INT-KG 100/3CA	100	37	37.5	INT-KG 100/6CA	100	37	37.5



IAT

On/off safety switches for 400°C/2h and 200°C/2h in accordance with Standard UNE-EN 60204-1.

Features:

- 400°C/2h and 200°C/2h switches to be placed beside the fan, so that the mains current can be cut off before handling the fan.
- Protection IP-65 model 400°C/2h and IP-55 model 200°C/2h

Model	Current (A)	Model	Current (A)
IAT-400-20/3P	20	IAT-400-63/6P	63
IAT-400-32/3P	32	IAT-400-125/6P	125
IAT-400-63/3P	63	IAT-200/16	16
IAT-400-125/3P	125	IAT-200/32	32
IAT-400-20/6P	20	IAT-200/63	63
IAT-400-32/6P	32		



CABLE BOX

Electrical cable and connection box kit 400°C/2h for external connections to the motor in fire-fighting installations

Features:

- Electrical six-wire cable and ground connection, with length of 1.5 m and terminals at each end
- Cast aluminium terminal board
- Terminal Strip in ceramic material

- Kit certified jointly with the CJBTD extractor series, with certification Number 0370-CPD-0580

Model	Maximum power motor 3x400V (kW)
CABLE BOX-1-400	5.5
CABLE BOX-2-400	15.0



C2V

Switch for two-speed motors

Features:

- 1-0-2 three-position switch to operate two-speed motors with Dahlander connection
- IP67 protection

Model	Current (A)	(kW)	Cable input (mm)
C2V-CG10 A441	20	5.5	20

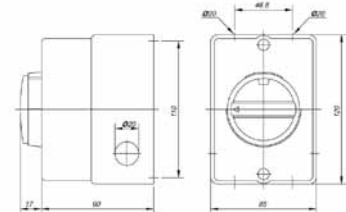

RM

Electronic speed controllers

Features:

- Electronic speed controllers especially designed for fans with single-phase motors, in accordance with standard EN-60335
- Models RM-1, RM-2 and RM-3, IP-54 protection. Models RM-00, RM-01 and RM-02, IP-44 protection
- In accordance with Electromagnetic Compatibility Directives 92/31/EEC and 93/68/EEC and in accordance with Low Voltage Directive 73/23/EEC

- On/off switch.
- Minimum speed adjustment
- With EMC filters in accordance with standard EN-55014

Model	Input voltage	Protection	Maximum current (A)
RM-00	230 V-50/60 Hz	IP-44	0.5
RM-01	230 V-50/60 Hz	IP-44	1
RM-02	230 V-50/60 Hz	IP-44	2
RM-1	230 V-50/60 Hz	IP-54	3
RM-2	230 V-50/60 Hz	IP-54	5
RM-3	230 V-50/60 Hz	IP-54	10

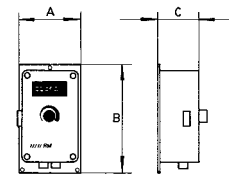

Model	A	B	C
RM-00	81	81	66
RM-01	81	81	66
RM-02	81	81	66
RM-1	80	145	80
RM-2	96	164	85
RM-3	96	164	85



AR

Soft starters for three-phase motors.

Features:

- Especially designed to reduce the current peak caused during start-up of fans with three-phase motors.
- Power Voltage 400V + - 10% 50/60Hz
- Mounted in box for DIN-35 rail
- Possibility of adjusting the starting torque, acceleration time and deceleration time.

Model	AR-2	AR-4	AR-7.5	AR-10	AR-15	AR-20	AR-30
Supplied voltage	400 V ±10% 50/60 Hz						
Motor power in kW at 400 V	1.5	3	5.5	7.5	11	15	22
Minimum motor power	40% of the motor's nominal power			20% of the motor's nominal power			
External fuses (quick-action) in (A)	16	25	35	25	35/40	50	63
Nominal current in (A)	3.5	6.5	12	17	25	32	45
Adjustment range of start-up torque	From 0 to 80%						
Adjustment range of start-up time	From 0.5 to 12 s			From 0.5 to 10 s			
Braking torque	Level set at 70%						
Adjustment range of deceleration time	From 0.5 to 12 s			From 0.5 to 10 s			
Setup time	200 ms						
Working temperature	0°C...45°C						
Storage temperature	-25°C...75°C						
Protection level	IP20						
Environmental conditions	Overpressure category III. Pollution level 2						
Power reduced with max. temperature	1% for every 1°C increase in the maximum temperature						
Maximum height for mounting	Up to 1000 m						
Power reduced with max. height	0.5% for every 100 m over 1000 m.						
Humidity	93% maximum without condensation						
Maximum cycles per hour (3 x I nom. 10 sec)	90/h	60/h	30/h	60/h	40/h	30/h	20/h
Weight in kg.	0.4			1.0			
Measurements	Width (W) mm	45			45		52.5
	Height (H) mm	73			173		178
	Depth (D) mm	122			152		158
Assembly	Fixing A x B			On DIN guide rail			



RFT RFM

Frequency converter for 400V three-phase motors.

Features:

- The RFT converter series are suitable to vary the speed, via voltage and frequency, of axial and centrifugal fans with 400V three-phase motors. Converter power supply: 400V three-phase. 50/60 Hz.
- In accordance with Electromagnetic Compatibility Directives 92/31/EEC and 93/68/EEC and in accordance with Low Voltage Directive 73/23/EEC

Features:

- The RFM converter series are suitable to vary the speed, via voltage and frequency, of axial and centrifugal fans with 230V three-phase motors. Converter power supply: 230V single-phase. 50/60 Hz.
- In accordance with Electromagnetic Compatibility Directives 92/31/EEC and 93/68/EEC and in accordance with Low Voltage Directive 73/23/EEC

Model	RFT-0.5	RFT-1	RFT-2	RFT-3	RFT-5.5	RFT-7.5	RFT-10	RFT-15	RFT-20	RFT-25	RFT-30	
Motor	(CV)	0.5	1	2	3	5.5	7.5	10	15	20	25	30
	(kW)	0.37	0.75	1.5	2.2	4	5.5	7.5	11	15	18.5	22
Current	(A)	1.25	2.5	4	6	9	12	16	24	30	39	45
kVA		0.95	1.9	3	4.5	6.9	9.1	12.2	19.1	23.9	31.1	35.9
	Input	Three-phase										
Voltage	(V)	3 x 380...480 V (-15% +10%)										
Frequency	(Hz)	50 - 60 Hz (± 5%)										
	Output	Three-phase										
Voltage	(V)	3 x 380...480 V										
Frequency	(Hz)	0...400 Hz						0...120 Hz				
Braking torque		20% (with external resistance: 100%. 150%)										
Braking unit		Incorporated in the equipment							Optional			
Size	Width (W1) mm	70	70	100	140	140	180	180	200	250	250	304
	Height (H1) mm	128	128	128	128	128	220	220	284	385	385	460
	Depth (D1) mm	130	130	130	155	155	170	170	182	201	201	234
Weight	(Kg)	0.76	0.77	1.12	1.84	1.89	3.66	3.66	6	12.5	13	20
Method of refrigeration		Forced air										

Model		RFM-0.5	RFM-1	RFM-2	RFM-3
Motor	(CV)	0.5	1	2	3
	(kW)	0.37	0.75	1.5	2.2
Current	(A)	2.5	5	8	12
kVA		0.95	1.9	3	4.5
	Input	Single-phase			
Voltage	(V)	2 x 200 ÷ 230 V (±10%)			
Frequency	(Hz)	50 – 60 Hz (± 5%)			
	Output	Three-phase			

Model		RFM-0.5	RFM-1	RFM-2	RFM-3
Voltage	(V)	3 x 200 ÷ 230 V			
Frequency	(Hz)	0-200 Hz	0-400 Hz	0-400 Hz	0-400 Hz
RFI Filter		Built in			
Size	Width (W1) mm	68	79	156	156
	Height (H1) mm	128	143	143	143
	Depth (D1) mm	115	143	143	143
Weight	(Kg)	0.95	0.97	1.94	2.00
Method of refrigeration		Radiator	Forced air	Forced air	Forced air

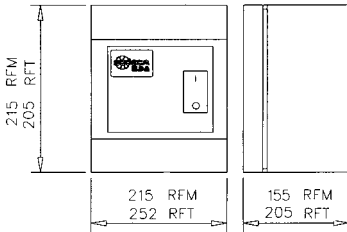

1. In general, all SODECA fans with a three-phase motor under normal operating conditions are suitable for working supplied with a static frequency converter (in accordance with IEC 60034-17). Nevertheless, some motors require special measures.

The maximum operating frequency or speed must never exceed that for which the fan has been designed. In applications with quadratic torques such as fans and pumps, when the speed varies the absorbed power is directly proportional to the cube of the rotating speed: $P_{a_2} = P_{a_1} (n_2 / n_1)^3$

2. The insulation of motors coupled to fans is sufficient to work without restrictions with a frequency converter up to voltages of < 500 V. The use of sinusoidal filters at the converter output will help the motor to operate properly, reducing breakdowns and increasing the fan's service life.

It is recommended that, for motors of sizes > 225, they be ordered with special windings to work with a frequency converter.

3. The length of the wires running from the converter to the fan have a particular influence on voltage characteristics at the motor terminals. The definition of "long wires" will depend on the nominal value and the converter type. The manufacturer's technical documentation must be consulted.

4. EEx-d flame-resistant motors must be ordered for operation using a frequency converter. The motor manufacturer will request information about the application via a questionnaire in order to establish the working parameters. These motors must also be fitted with PTC probes.

5. EEx-e increased safety motors cannot be operated with a frequency converter (a joint motor-converter certification would be required for this).



KME - 10K

External control kit for On/Off and velocity control for RFM and RFT frequency converters

Features:

- On/Off by button
- Display by means of LED of the position of On or Off
- Memory of the latest position for speed regulation

- Possibility of installation on the surface or built-in



GMP

Electrical starter panel and protection of fans with three-phase motor, with On/Off buttons

Features:

- On/Off by button
- Incorporates fully-cabled contactor and adjustable thermal relay for protection of the motor
- The Off button is used to reset the thermal relay, in case it should go off due to overload
- For assembly on the surface, IP-55 protection

For fan with three-phase motor 230V

Model	Current of regulation (A)	Power motor 3x230V (kW)
GMP-0.2-0.33/230	1.2-1.8	0.25
GMP-0.2-0.75/230	1.8-2.8	0.37 / 0.55
GMP-0.2-1/230	2.8-4	0.75
GMP-0.2-1.5/230	4-6.3	1.10
GMP-0.2-2/230	5.6-8	1.50
GMP-0.4-3/230	7-10	2.20
GMP-0.4-4/230	8-12.5	3.00
GMP-0.4-5.5/230	11-17	4.00
GMP-0.4-7.5/230	15-23	5.50
GMP-0.4-10/230	22-32	7.50
GMP-0.6-12.5/230	25-40	9.20
GMP-0.6-15/230	25-40	11.00

For fan with three-phase motor 400V

Model	Current of regulation (A)	Power motor 3x400V (kW)
GMP-0.2-0.33/400	0.56-0.8	0.25
GMP-0.2-0.5/400	0.8-1.2	0.37
GMP-0.2-0.75/400	1.2-1.8	0.55
GMP-0.2-1.5/400	1.8-2.8	1.10
GMP-0.2-2/400	2.8-4	1.50
GMP-0.2-3/400	4-3	2.20
GMP-0.2-4/400	5.6-8	3.00
GMP-0.4-5.5/400	7-10	4.00
GMP-0.4-7.5/400	8-12.5	5.50
GMP-0.4-10/400	11-17	7.50
GMP-0.6-12.5/400	15-23	9.20
GMP-0.6-15/400	15-23	11.00
GMP-0.6-20/400	22-32	15.00
GMP-0.6-25/400	25-40	18.50



GMM Electrical starter panel and protection from overload and short-circuits of fans with three-phase motor, with rotary controls

Features:

- On/Off by means of a rotary control with the possibility of blocking with three locks
- Incorporates adjustable thermal relay for protection from overload and short-circuit
- For assembly on the surface, IP-55 protection

For fan with three-phase motor 400V

Model	Current of regulation (A)	Power motor 3x400V (kW)
GMM-01-1/400	1.6-2.5	0.75
GMM-01-2/400	2.5-4	1.10 1.50
GMM-01-3/400	4-6.3	2.20
GMM-01-5.5/400	6.3-10	3.00 4.00
GMM-01-7.5/400	10-16	5.50
GMM-01-10/400	16-20	7.50
GMM-01-15/400	20-25	11.00
GMM-01-20/400	25-32	15.00



AET Electrical starter panel, star / triangle and protection of fans with three-phase motor, with On/Off buttons

Features:

- On/Off by button
- Display of condition by means of luminous pilot lights
- Incorporates adjustable thermal relay for protection of the motor
- Fully cabled
- Metal plate for assembly on the surface, IP-65 protection

For fan with three-phase motor 230V/400V.
Power supply 3x230V

Model	Current regulation of thermal relay (A)	Power motor 3x230/400V (kW)
AET-01-3/230	4-6,3	2,2
AET-01-4/230	5-8	3,0
AET-01-5,5/230	7-10	4,0
AET-01-7,5/230	12-18	5,5
AET-01-10/230	12-18	7,5
AET-01-15/230	18-26	11,0
AET-01-20/230	24-36	15,0
AET-01-25/230	28-40	18,5
AET-02-30/230	34-50	22,0
AET-02-40/230	45-65	30,0
AET-02-50/230	63-85	37,0

For fan with three-phase motor 400V/690V.
Power 3x400V+N

Model	Current regulation of thermal relay (A)	Power motor 3x400/690V (kW)
AET-01-5,5/230	4-6,3	4,0
AET-01-7,5/230	5-8	5,5
AET-01-10/230	7-10	7,5
AET-01-15/230	12-18	11,0
AET-01-20/230	12-18	15,0
AET-02-30/230	18-26	18,5 22,0
AET-02-40/230	28-40	30,0
AET-02-50/230	34-50	37,0
AET-02-60/230	45-65	45,0
AET-02-75/230	45-65	55,0



AD Electrical starter panel and protection of fans with three-phase motor, with two DAHLANDER speeds

Features:

- Switch for selecting speed (1-0-2), Low-Off-High.
- Display of condition by means of luminous pilot lights
- Incorporates adjustable thermal relay for protection of the motor
- Fully cabled
- Metal plate for assembly on the surface, IP-65 protection

For fan with three-phase 400V Dahlander motor.
Power 3x400V+N

Model	Current regulation of thermal relay	
	High speed (A)	Low speed (A)
AD-01-2.5-1/400	1.6-2.5	0.63-1
AD-01-4-1.6/400	2.5-4	1-1.6
AD-01-4-2.5/400	2.5-4	1.6-2.5
AD-01-6-2.5/400	4-6	1.6-2.5
AD-01-9-2.5/400	6-9	1.6-2.5
AD-01-9-4/400	6-9	2.5-4
AD-02-13-4/400	9-13	2.5-4
AD-02-18-6/400	12-18	4-6
AD-02-18-9/400	12-18	6-9
AD-02-26-9/400	18-26	6-9
AD-02-36-9/400	24-36	6-9
AD-02-36-13/400	24-36	9-13
AD-02-40-18/400	28-40	12-18



ACO Automatic switch for changing the fan in case of a fault

Features:

- Automatic programme for fault diagnosis when starting the fan
- Detection of faults by intensity or by air flow
- Automatic switching to the reserve fan, on detecting a problem in the faulty fan
- Possibility of adjusting different times of operation, for both fans

Model	Maximum current (A)	Input voltage (V)
ACO-08-M	8	1x220/240V 50/60Hz
ACO-09-T	9	3x400/415V 50/60Hz



MTP010 Brushless motor speed control



PL Plastic backdraught louver.

Features:

- The backdraught louver is adapted directly to the wall where the fan is mounted.
- Opening through excess pressure due to airflow
- Closed when the fan is on standby
- Made from plastic
- Maximum recommended speed 12m/sec for models 80, 90 and 100

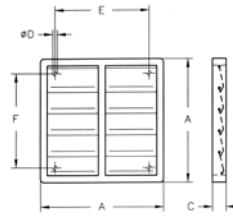

Model	Measurements				
	A	C	ØD	E	F
PL-20	240	28	5.2	193	167
PL-25	294	26	5	232	232
PL-31	347	26	5	276	276
PL-35	397	26	5	310	310
PL-40	459	26	5	364	364
PL-45	501	26	5	395	395
PL-50	549	31	5	445	445
PL-56	605	28	5	522	522
PL-63	696	31	5	626	626
PL-71	760	40	5	692	692
PL-80	840	40	5	772	772
PL-90	940	40	5	872	87
PL-100	1040	40	5	972	972



P Aluminium backdraught louver

Features:

- The backdraught louver is adapted directly to the wall where the fan is mounted.
- Opening through excess pressure due to airflow
- Closed when the fan is on standby
- Aluminium sheet construction
- Maximum recommended speed 18m/sec for models 90 and 100

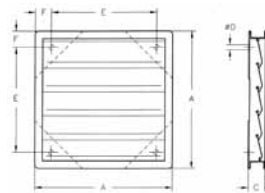

Model	Measurements				
	A	C	ØD	E	F
P-25	290	51	6	187	51.5
P-35	400	81	6	266	67
P-45	500	51	6	347	76.5
P-56	600	51	6	447	76.5
P-63	715	72	6	535	90
P-71	780	72	6	605	87.5
P-80	875	72	6	675	100
P-90	970	72	6	755	107.5
P-100	1070	72	6	850	110



RPA Protection guard for inlet of centrifugal fans.

Features:

- Protects against contact with the impeller and prevents objects from entering, in accordance with standard UNE-100250
- Made from sheet steel.

Applies to models

Model	CMA CMAT	CMC	CB	CBP	CAS	CA	CAM	CMP	CMT	CMR-X CMR
RPA-10	-	-	-	-	-	-	-	38	-	-
RPA-11	218	-	-	-	-	-	-	-	-	-
RPA-13	324	-	-	-	-	234	-	-	-	-
RPA-15	325/426	-	-	-	242	142	-	512	-	-
RPA-17	527	-	-	-	248	148	-	514	-	-
RPA-18	528	-	-	-	254	154	-	-	-	-
RPA-20	531	-	-	-	260	-	-	616	-	-
RPA-23	-	628/630	-	-	680	160/166/172	540/545	718	922	-
RPA-25	540/545	835/840	820	-	790	-	-	620/820	1025	-
RPA-28	-	-	-	-	463/467	-	550/752	922	1128	-
RPA-31	-	-	1428	-	-571/640/645/650/980/1080-	-	760	1025	1231	-
RPA-35	-	-	-	-	-852/990/1090	-	-	1128	1435/1640	-
RPA-38	-	-	1733	-	-	-	880	1231	-	1031
RPA-42	-	-	-	-	856	-	-	1435	1845	1135
RPA-44	-	-	-	-	1250/A	-	-	-	-	-
RPA-47	-	-	2240	-	863/971	-	-	1640	2050	1240
RPA-48	-	-	-	-	1456/A	-	-	-	-	-
RPA-52	-	-	-	1445	-	-	-	1845	-	1445
RPA-55	-	-	-	-	-	-	-	-	-	-
RPA-60	-	-	-	1650	-	-	-	2050	-	1650
RPA-65	-	-	-	-	1663/A	-	-	-	-	-
RPA-66	-	-	-	1856	-	-	-	-	-	1856
RPA-73	-	-	-	-	-1671/A-2071/A	-	-	2563	-	2063
RPA-81	-	-	-	-	2080/A	-	-	-	-	2271
RPA-88	-	-	-	-	-	-	-	-	-	2380
RPA-90	-	-	-	-	-	-	-	-	-	2590
RPA-100	-	-	-	-	-	-	-	-	-	28100



B

Coupling flange for centrifugal fans.

Features:

- Adapted to inlet and outlet.
- Facilitates duct installation

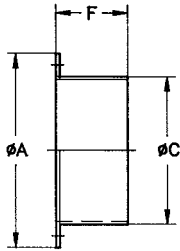

	A	C	F		A	C	F		A	C	F		A	C	F
B-52-E	100	52	67	B-224	280	224	60	B-355/2	430	355	80	B-500/5	590	500	80
B-63	110	63	60	B-250/1	310	250	80	B-355/3	430	355	80	B-560/1	650	560	80
B-80	150	80	60	B-250/2	310	250	80	B-355/4	430	355	80	B-560/2	650	560	80
B-80-E	150	80	60	B-250/3	310	250	80	B-400/1	480	400	80	B-560/3	650	560	80
B-100	150	100	60	B-250/4	310	250	80	B-400/2	480	400	80	B-630/1	720	630	80
B-100-E	170	100	60	B-250/5	310	250	80	B-400/3	480	400	80	B-630/2	720	630	80
B-112	160	112	60	B-280/1	350	280	80	B-400/4	480	400	80	B-630/3	720	630	80
B-125	180	125	60	B-280/2	350	280	80	B-450/1	530	450	80	B-630/4	720	630	80
B-140	190	140	60	B-280/3	350	280	80	B-450/2	530	450	80	B-710/1	800	710	80
B-150	210	150	60	B-315/1	350	315	80	B-450/3	530	450	80	B-710/2	800	710	80
B-160	220	160	60	B-315/2	380	315	80	B-500/1	590	500	80	B-710/3	800	710	80
B-160/1	220	160	60	B-315/3	380	315	80	B-500/2	590	500	80	B-800	890	800	100
B-180	240	180	60	B-315/4	380	315	80	B-500/3	590	500	80	B-900/1	1000	900	100
B-200	260	200	60	B-355/1	430	355	80	B-500/4	590	500	80	B-1000/1	1100	1000	100

Applies to models (INLET)

Applies to models (OUTLET)

Model	CMA CMAT	CB	CAS	CA	CAM	CMP	CMC	CMT	CBP	CMR-X CMR	CMAT CMA	CA
B-52-E	-	-	-	-	-	-	-	-	-	-	-	234
B-63	-	-	-	-	-	-	-	-	-	-	218/324	142
B-80	218/324	-	-	-	-	-	-	-	-	-	325	-
B-80-E	-	-	-	-	-	-	-	-	-	-	-	-148/154/160/166
B-100	325	-	-	234	-	-	-	-	-	-	426/527	-
B-100-E	-	-	242	142	-	-	-	-	-	-	-	172
B-112	426	-	248	148	-	512	-	-	-	-	-	-
B-125	527/528	-	254	154	-	-	-	-	-	-	528	-
B-140	-	-	-	-	-	514	-	-	-	-	-	-
B-150	531	-	260	160	-	-	628/630	-	-	-	531/540	-
B-160	-	-	-	-	-	616	-	-	-	-	-	-
B-160/1	-	-	680	-	-	-	-	-	-	-	-	-
B-180	540/545	-	790	166/172	540/545	718	-	922	-	-	545	-
B-200	-	820	463	-	-	620/820	835/840	1025	-	-	-	-
B-224	-	-	467	-	550/752	922	-	1128	-	-	-	-
B-250/1	-	-	571/640/645/650	-	-	-	-	1231	-	-	-	-
B-250/2	-	-	-	-	760	-	-	-	-	-	-	-
B-250/3	-	-	-	-	-	1025	-	-	-	-	-	-
B-250/4	-	1428	-	-	-	-	-	-	-	-	-	-
B-250/5	-	-	980/1080	-	-	-	-	-	-	-	-	-
B-280/1	-	-	852	-	-	-	-	1435/1640	-	-	-	-
B-280/2	-	-	-	-	-	1128	-	-	-	-	-	-
B-280/3	-	-	9907/1090	-	-	-	-	-	-	-	-	-
B-315/1	-	1733	-	-	-	-	-	-	-	-	-	-
B-315/2	-	-	-	-	880	-	-	-	-	-	-	-
B-315/3	-	-	-	-	-	-	-	-	-	1031	-	-
B-315/4	-	-	-	-	-	1231	-	-	-	-	-	-
B-355/1	-	-	-	-	-	-	-	-	-	1135	-	-
B-355/2	-	2240	863	-	-	-	-	-	-	-	-	-
B-355/3	-	-	856	-	-	1435	-	1845	-	-	-	-
B-355/4	-	-	1250/A	-	-	-	-	-	-	-	-	-
B-400/1	-	-	-	-	-	1640	-	-	-	-	-	-
B-400/2	-	-	-	-	-	-	-	-	-	1240	-	-
B-400/3	-	-	971	-	-	-	-	2050	-	-	-	-
B-400/4	-	-	1456/A	-	-	-	-	-	-	-	-	-
B-450/1	-	-	-	-	-	1845	-	-	-	-	-	-
B-450/2	-	-	-	-	-	-	-	-	-	1445	-	-
B-450/3	-	-	-	-	-	-	-	-	1445	-	-	-
B-500/1	-	-	-	-	-	2050	-	-	-	-	-	-
B-500/2	-	-	-	-	-	-	-	-	-	1650	-	-
B-500/3	-	-	-	-	-	-	-	-	1650	-	-	-
B-560/1	-	-	-	-	-	-	-	-	1856	-	-	-
B-560/2	-	-	-	-	-	-	-	-	-	1856	-	-
B-560/3	-	-	1663/A	-	-	-	-	-	-	-	-	-
B-630/1	-	-	-	-	-	2563	-	-	-	-	-	-
B-630/2	-	-	-	-	-	-	-	-	-	2063	-	-
B-630/3	-	-	-	-	-	-	-	-	-	-	-	-
B-630/4	-	-	-1671/A-2071/A	-	-	-	-	-	-	-	-	-
B-710/1	-	-	-	-	-	-	-	-	-	2271	-	-
B-710/3	-	-	2080/A	-	-	-	-	-	-	-	-	-
B-800	-	-	-	-	-	-	-	-	-	2380	-	-
B-900/1	-	-	-	-	-	-	-	-	-	2590	-	-
B-1000/1	-	-	-	-	-	-	-	-	-	28100	-	-



BD

Dual coupling flange for centrifugal fans

Features:

- Adapted to the inlet
- Facilitates duct installation with flange

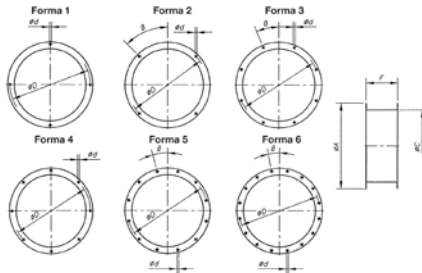

	ØA	ØC	ØD	Ød	F	β	Form
BD-200	260	200	225	7	80	15°	2
BD-224	280	224	254	7	80	-	1
BD-250/1	310	250	280	10	80	45°	2
BD-280	350	280	320	10	100	-	4
BD-315/3	390	315	355	10	100	22°30'	3
BD-355/3	430	355	395	10	100	22°30'	3
BD-400/1	480	400	450	12	100	22°30'	3
BD-400/2	480	400	450	12	100	22°30'	3
BD-450/1	530	450	500	12	100	22°30'	3
BD-450/2	530	450	500	12	100	22°30'	3
BD-500/2	590	500	560	12	100	15°	5
BD-560	650	560	620	12	120	15°	5
BD-630/2	720	630	690	12	120	15°	5
BD-710	800	710	770	12	120	11°15'	6

Applies to models

Model	CB	CMP	CMR-X CMR	CMC
BD-112	-	512	-	-
BD-140	-	514	-	-
BD-160	-	616	-	628/630
BD-180	-	718	-	-
BD-200	820	620/820	-	835/840
BD-224	-	922	-	-
BD-250/1	-	1025	-	-
BD-250/2	1428	-	-	-
BD-280	-	1128	-	-
BD-315/1	1733	-	-	-

Applies to models

Model	CB	CMP	CMR-X CMR	CMC
BD-315/2	-	-	1031	-
BD-315/3	-	1231	-	-
BD-355/1	-	-	1135	-
BD-355/2	2240	-	-	-
BD-355/3	-	1435	-	-
BD-400/1	-	1640	-	-
BD-400/2	-	-	1240	-
BD-450/1	-	1845	-	-
BD-450/2	-	-	1445	-
BD-500/1	-	2050	-	-

Applies to models

Model	CB	CMP	CMR-X CMR	CMC
BD-500/2	-	-	1650	-
BD-560	-	-	1856	-
BD-630/1	-	2563	-	-
BD-630/2	-	-	2063	-
BD-710	-	-	2271	-
BD-800	-	-	2380	-
BD-900/1	-	-	2590	-
BD-1000/1	-	-	28100	-



BIC

Flange conversion from rectangular to circular for centrifugal fans.

Features:

- Adapted to the outlet
- Aids installation on circular duct

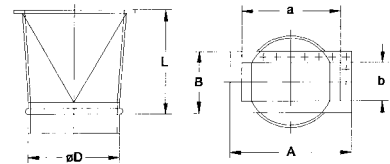

Model	L	D	a	b	A	B	Applies to models
BIC-820-CB	300	200	160	130	213	184	CB-820
BIC-1428	300	250	286	202	350	260	CB-1428
BIC-1733	300	280	339	240	415	315	CB-1733
BIC-2240	450	355	400	300	478	372	CB-2240
BIC-628	200	150	86	86	130	130	CMC-628
BIC-630	200	150	86	86	130	130	CMC-630
BIC-835	200	200	91	91	141	141	CMC-835
BIC-840	200	200	91	91	141	141	CMC-840
BIC-242	200	100	95	60	155	120	CAS/CAST-242
BIC-248	200	112	105	66	165	126	CAS/CAST-248
BIC-254	200	125	115	75	175	135	CAS/CAST-254
BIC-260	200	150	125	85	185	145	CAS/CAST-260
BIC-463	200	200	125	85	185	145	CAS/CAST-463
BIC-467	250	224	130	90	190	150	CAS/CAST-467
BIC-571	250	250	145	95	205	155	CAS/CAST-571
BIC-640	250	250	200	125	260	185	CAS/CAST-640
BIC-645	250	250	224	140	284	200	CAS/CAST-645
BIC-650	250	250	250	160	310	220	CAS/CAST-650
BIC-680	250	180	100	71	160	131	CAS-680
BIC-790	250	180	112	80	172	140	CAS-790
BIC-852	250	280	280	180	340	240	CAS/CAST-852
BIC-856	280	355	280	180	340	240	CAS/CAST-856
BIC-863	280	355	315	200	375	260	CAS/CAST-863
BIC-971	280	400	355	224	425	294	CAS/CAST-971
BIC-980	300	250	200	140	270	210	CAS/CAST-980
BIC-990	300	280	224	160	294	230	CAS-990
BIC-1080	300	250	200	140	270	210	CAS-1080
BIC-1090	300	280	224	160	294	230	CAS-1090
BIC-1250	450	400	400	280	480	360	CAS/CAST-1250/A
BIC-1456	450	450	450	315	530	395	CAS/CAST-1456/A
BIC-1663	450	500	500	355	580	435	CAS/CAST-1663/A
BIC-1671	450	630	560	400	660	500	CAS-1671/A-2071/A
BIC-2080	450	710	630	450	730	550	CAS-2080/A
BIC-540	300	180	140	120	224	206	CAM-540
BIC-545	300	180	170	135	255	222	CAM-545
BIC-550	300	224	200	150	296	246	CAM-550
BIC-752	300	224	200	160	296	256	CAM-752
BIC-760	300	250	220	180	316	276	CAM-760
BIC-880	300	315	290	190	360	249	CAM-880
BIC-1445/E	450	450	450	355	538	445	CBP-1445

Model	L	D	a	b	A	B	Applies to models
BIC-1650/E	450	500	500	400	590	490	CBP-1650
BIC-1856/E	450	560	560	450	660	550	CBP-1856
BIC-512	300	112	86	75	118	104	CMP-512
BIC-514	300	140	107	83	147	122	CMP-514
BIC-616	300	160	125	103	172	153	CMP-616
BIC-620	300	200	100	105	153	159	CMP-620
BIC-718	300	180	146	115	192	169	CMP-718
BIC-820	300	200	156	160	213	184	CMP-820
BIC-922	300	224	216	140	282	204	CMP-922
BIC-1025	300	250	250	165	314	229	CMP-1025
BIC-1128	300	280	300	180	364	244	CMP-1128
BIC-1231	300	315	320	200	384	266	CMP-1231
BIC-1435	300	355	280	228	344	294	CMP-1435
BIC-1640	300	400	320	250	404	336	CMP-1640
BIC-1845	450	450	360	284	444	370	CMP-1845
BIC-2050	450	500	450	315	545	412	CMP-2050
BIC-2563	450	630	600	410	706	512	CMP-2563
BIC-922-T	300	180	216	140	282	204	CMT-922
BIC-1025-T	300	200	250	165	314	229	CMT-1025
BIC-1128-T	300	224	300	180	364	244	CMT-1128
BIC-1231-T	300	250	320	200	384	266	CMT-1231
BIC-1435-T	300	280	280	228	344	294	CMT-1435
BIC-1640-T	300	280	320	250	404	336	CMT-1640
BIC-1845-T	450	355	360	284	444	370	CMT-1845
BIC-2050-T	450	400	450	315	545	412	CMT-2050
BIC-1031	300	315	315	250	385	320	CMR-1031
BIC-1135	450	355	355	280	425	350	CMR-1135
BIC-1240	450	400	400	315	480	395	CMR-1240
BIC-1445	450	450	450	355	540	445	CMR-1445
BIC-1650	450	500	500	400	590	490	CMR-1650
BIC-1856	450	560	560	450	660	550	CMR-1856
BIC-2063	450	630	630	500	750	620	CMR-2063
BIC-2271	450	710	710	560	840	690	CMR-2271
BIC-2380	600	800	800	560	920	680	CMR-2380
BIC-2380/E	600	800	1120	560	1246	690	CMR-2380-X
BIC-2590	600	900	900	630	1020	750	CMR-2590
BIC-28100	600	1000	1000	710	1120	830	CMR-28100
BIC-1840	150	370	273	210	353	303	CPV-1840
BIC-2045	190	400	330	270	420	360	CPV-2045



PSB

Set of support stand for low-pressure centrifugal fans

Features:

- Two-part set to allow fixing to flat surfaces

Model	Applies to models
PSB-1428	CB-1428
PSB-1733	CB-1733
PSB-19	CBD-1919, CBX-1919

Model	Applies to models
PSB-25	CBD-2520, CBD-2525, CBX-2525
PSB-28	CBD-2821, CBD-2828, CBX-2828
PSB-33	CBD-3325, CBD-3333, CBX-3333

Model	Applies to models
PSB-39	CBD-3939, CBX-3939
PSB-47	CBX-4747



SM

Motor mounting bracket and belt tensing device for low-pressure centrifugal fans

Features:

- Two-part set to mount the motor on the fan casing

Model	Applies to models
SM-19	CBX-1919
SM-25	CBX-2525

Model	Applies to models
SM-28	CBX-2828
SM-33	CBX-3333

Model	Applies to models
SM-39	CBX-3939
SM-47	CBX-4747



VIS

Outlet hood with protection guard.

Features:

- Prevents objects and water from entering the fan.

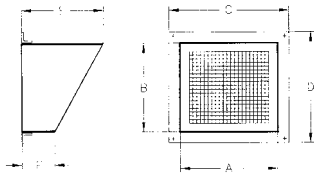

	A	B	C	D	E	F
VIS-7/7	245	224	-	-	200	80
VIS-9/9	312	281	-	-	200	80
VIS-10/10	340	306	-	-	200	80
VIS-12/12	400	358	-	-	300	80
VIS-15/15	488	420	-	-	300	80
VIS-18/18	570	496	-	-	300	80
VIS-20/20	618	620	-	-	500	80
VIS-22/22	670	710	-	-	500	80
VIS-25/25	780	809	-	-	500	80
VIS-30/28	905	948	-	-	500	80
VIS-820	132	157	-	-	170	56.5
VIS-922	142	216	-	-	215	56.5
VIS-1025	167	251	-	-	240	56.5
VIS-1128	182	296	-	-	270	56.5
VIS-1231	202	321	-	-	290	56.5
VIS-1240	317	401	-	-	350	56.5
VIS-1435	232	281	-	-	260	56.5
VIS-1445	357	451	-	-	385	56.5
VIS-1640	252	321	-	-	290	56.5

	A	B	C	D	E	F
VIS-650	402	501	-	-	420	56.5
VIS-1845	286	361	-	-	320	56.5
VIS-1856	452	561	-	-	-	-
VIS-2050	317	451	-	-	385	56.5
VIS-2063	502	631	-	-	515	56.5
VIS-2271	562	716	-	-	575	56.5
VIS-1131	560	450	-	-	250	100
VIS-1235	620	500	-	-	250	100
VIS-1640/E	710	560	-	-	250	100
VIS-1845/E	800	630	-	-	250	100
VIS-1856/E	1000	800	-	-	250	100
VIS-2063/E	1120	900	-	-	250	100
VIS-2271/E	1190	900	-	-	250	100
VIS-2880	1250	1000	-	-	250	100
VIS-100	600	600	698	698	485	-
VIS-200	725	725	823	823	576	-
VIS-300	800	800	898	898	630	-
VIS-400	860	860	958	958	674	-

Model	Applies to models		
	CJBD	CJBD/AL	CJBX
VIS-7/7	1919	-	7/7
VIS-9/9	2525	-	9/9
VIS-10/10	2828	-	10/10
VIS-12/12	3333	-	12/12
VIS-15/15	3939	-	15/15

Model	Applies to models		
	CJBD	CJBD/AL	CJBX
VIS-18/18	-	-	18/18
VIS-20/20	-	-	20/20
VIS-22/22	-	-	22/22
VIS-25/25	-	-	25/25
VIS-30/28	-	-	30/28

Model	Applies to models		
	CJBD	CJBD/AL	CJBX
VIS-7/7-AL	-	1919	-
VIS-9/9-AL	-	2525	-
VIS-10/10-AL	-	2828	-
VIS-12/12-AL	-	3333	-
VIS-15/15-AL	-	3939	-



ACE Elastic coupling to absorb vibrations

Features:

- Used between the fan inlet/outlet and the duct to avoid transmitting vibrations

Applies to models (INLET)

Applies to models (OUTLET)

Model	Applies to models (INLET)								Applies to models (OUTLET)								
	CMAT	CB	CAS	CA	CAM	CMP	CMT	CMR	CMAT	CAS	CA	CAM	CB	CMP	CMT	CMR	
ACE-52	-	-	-	-	-	-	-	-	-	-	234	-	-	-	-	-	
ACE-63	-	-	-	-	-	-	-	-	218/324	-	142	-	-	-	-	-	
ACE-80	218/324	-	-	-	-	-	-	-	-	325	-	148/154/160/166	-	-	-	-	
ACE-100	325	-	242	234/142	-	-	-	-	-	426/527	242	172	-	-	-	-	
ACE-112	426	-	248	148	-	512	-	-	-	-	248	-	-	512	-	-	
ACE-125	527/528	-	254	154	-	-	-	-	-	528	254	-	-	-	-	-	
ACE-140	-	-	-	-	-	514	-	-	-	-	-	-	-	514	-	-	
ACE-150	531	-	260	160	-	-	-	628/630	531/540	260	-	-	-	-	-	628/630	
ACE-160	-	-	680	-	-	616	-	-	-	-	-	-	-	616	-	-	
ACE-180	540/545	-	790	166/172	540/545	718	922	-	-	545	680/790	-	540/545	718	922	-	
ACE-200	-	820	463	-	-	620/820	1025	-	-	835/840	-	463	-	820	620/820	1025	-
ACE-224	-	-	467	-	550/752	922	1128	-	-	-	467	-	550/752	922	1128	-	
ACE-250	-	1428	571/640/645 650/980/1080	-	760	1025	1231	-	-	-	570/640/645 650/980/1080	-	760	1428	1025	1231	-
ACE-280	-	-	852/990/1090	-	-	1128	1435/1640	-	-	-	852/990/1090	-	-	1733	1128	1435/1640	-
ACE-315	-	1733	-	-	880	1231	-	1031	-	-	-	-	880	-	1231	-	1031
ACE-355	-	2240	856/863/1250/A	-	-	1435	1845	-	1135	-	856/863	-	-	2240	1435	1845	1135
ACE-400	-	-	971/1456/A	-	-	1640	2050	-	1240	-	971/1456/A	-	-	1640	2050	1240	-
ACE-450	-	-	-	-	-	1845	-	1445	1445	-	1456/A	-	-	1845	-	1445	-
ACE-500	-	-	-	-	-	2050	-	1650	1650	-	1663/A	-	-	2050	-	1650	-
ACE-560	-	-	1663/A	-	-	-	-	1856	1856	-	-	-	-	-	-	1856	-
ACE-630	-	-	1671/A-2071/A	-	-	2563	-	2063	2063	-	1671/A-2071/A	-	-	2563	-	2063	-
ACE-710	-	-	2080/A	-	-	-	-	2271	-	-	2080/A	-	-	-	-	2271	-
ACE-800	-	-	-	-	-	-	-	2380	-	-	-	-	-	-	-	2380	-
ACE-900	-	-	-	-	-	-	-	2590	-	-	-	-	-	-	-	2590	-
ACE-1000	-	-	-	-	-	-	-	28100	-	-	-	-	-	-	-	28100	-



REG Record of manual regulation

Features:

- Their design allows them to be installed in ducting systems to adjust the airflow.

Model	L	ØD*	Model	L	ØD*
REG-80	100	80	REG-250	100	250
REG-100	100	100	REG-280	100	280
REG-112	100	112	REG-315	100	315
REG-125	100	125	REG-355	100	355
REG-140	100	140	REG-400	100	400
REG-150	100	150	REG-450	150	450
REG-160	100	160	REG-500	150	500
REG-180	100	180	REG-560	150	560
REG-200	100	200	REG-630	250	630
REG-224	100	224	REG-800	250	800



TEJ Outside covers.

Features:

- Avoids water entering ventilation units installed outside.

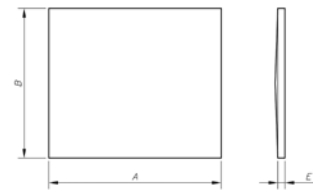

Model	Applies to models					Model	Applies to models					Model	Applies to models			Model	Applies to models		
	CJBD	CJBX		CJBX			CJBD/AL	CJBX/AL		CJBX			CJBD/AL	CJBX/AL					
TEJ-1919	460	510	-	-	30	TEJ-1919-AL	460	530	-	-	30	TEJ-1919	1919	-	TEJ-1919-AL	1919	-		
TEJ-2525	510	560	-	-	30	TEJ-2525-AL	510	600	-	-	30	TEJ-2525	2525	-	TEJ-2525-AL	2525	-		
TEJ-2828	560	610	-	-	30	TEJ-2828-AL	560	700	-	-	30	TEJ-2828	2828	-	TEJ-2828-AL	2828	-		
TEJ-3333	660	710	-	-	30	TEJ-3333-AL	660	810	-	-	30	TEJ-3333	3333	-	TEJ-3333-AL	3333	-		
TEJ-3939	810	810	-	-	30	TEJ-3939-AL	810	960	-	-	30	TEJ-3939	3939	-	TEJ-3939-AL	3939	-		
TEJ-7/7	-	-	660	510	30	TEJ-7/7-AL	-	-	680	460	30	TEJ-7/7	-	7/7	TEJ-7/7-AL	-	7/7		
TEJ-9/9	-	-	710	560	30	TEJ-9/9-AL	-	-	730	580	30	TEJ-9/9	-	9/9	TEJ-9/9-AL	-	9/9		
TEJ-10/10	-	-	760	610	30	TEJ-10/10-AL	-	-	810	680	30	TEJ-10/10	-	10/10	TEJ-10/10-AL	-	10/10		
TEJ-12/12	-	-	860	710	30	TEJ-12/12-AL	-	-	930	750	30	TEJ-12/12	-	12/12	TEJ-12/12-AL	-	12/12		
TEJ-15/15	-	-	1010	810	30	TEJ-15/15-AL	-	-	1000	910	30	TEJ-15/15	-	15/15	TEJ-15/15-AL	-	15/15		
TEJ-18/18	-	-	1210	1010	30	TEJ-18/18-AL	-	-	1160	1000	30	TEJ-18/18	-	18/18	TEJ-18/18-AL	-	18/18		
TEJ-20/20	-	-	1410	1110	30	TEJ-20/20-AL	-	-	1420	1270	30	TEJ-20/20	-	20/20	TEJ-20/20-AL	-	20/20		
TEJ-22/22	-	-	1490	1260	30	TEJ-22/22-AL	-	-	1540	1340	30	TEJ-22/22	-	22/22	TEJ-22/22-AL	-	22/22		
TEJ-25/25	-	-	1670	1460	30	TEJ-25/25-AL	-	-	1660	1525	30	TEJ-25/25	-	25/25	TEJ-25/25-AL	-	25/25		
TEJ-30/28	-	-	1810	1660	30	TEJ-30/28-AL	-	-	1910	1725	30	TEJ-30/28	-	30/28	TEJ-30/28-AL	-	30/28		

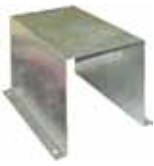

CM Motor cover for outside work.

- Features:
- Avoids water entering motors installed outside.



Model	A	B	C	D	Applies to motors of:
					CV
CM-1	15	260	200	300	0.25 to 1
CM-2	15	260	240	300	1.5 to 2
CM-5,5	15	300	270	330	3 to 5.5
CM-10	15	380	320	450	7.5 to 10
CM-20	15	440	350	530	15 to 20
CM-30	15	440	360	550	more than 20



TAC Circular coupling plate.

- Features:
- To change rectangular outlet of unit CJS, CJBR and CJLINE to circular

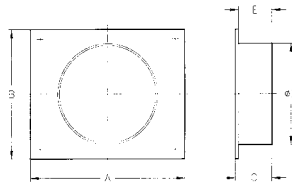

	A	B	C	ØD	E	Applies to models
						CJBR
TAC-100	698	698	80	400	50	1240/1850
TAC-200	823	823	80	560	50	2056/2263-6T
TAC-300	898	898	80	630	50	2263-4T/2071-6T-3
TAC-400	958	958	80	710	50	2071-4T/6T-5.5/2880



VOL Casing for ventilation recirculating ovens

- Features:
- Casing for CMRH fan, designed to be installed inside the oven

Model	Applies to models
VOL-1445	CMRH-1445
VOL-1650	CMRH-1650
VOL-1856	CMRH-1856
VOL-2063	CMRH-2063
VOL-2271	CMRH-2271
VOL-2380	CMRH-2380



ARO Inlet for fans recirculating ovens

- Features:
- Inlet for CMRH fan, designed to be installed in VOL casing

Model	Applies to models
ARO-1445	CMRH-1445
ARO-1650	CMRH-1650
ARO-1856	CMRH-1856
ARO-2063	CMRH-2063
ARO-2271	CMRH-2271
ARO-2380	CMRH-2380



CJACUS Soundproof boxes for centrifugal fans

- Features:
- Ventilation box in galvanised sheet steel with acoustic insulation
 - Mounting feet and Silent-Blocks included
 - CJACUS/C: With inlet and outlet connection outside through ducts Motor cooling grille vent included
 - CJACUS/L: With free inlet through vent built into the box and outlet connection to the outside

Model	Applies to models		
	CAS	CA	CAM
CJACUS-0	640	154	540
CJACUS-1	254/645	160	545
CJACUS-2	260/463/650	166	550/752
CJACUS-3	467/852/856	172	-
CJACUS-4	571/863	-	760
CJACUS-5	971	-	880



S Silencers to fit to inlet or outlet.

Features:

- Circular or rectangular silencers to fit to inlet or outlet on centrifugal fans.

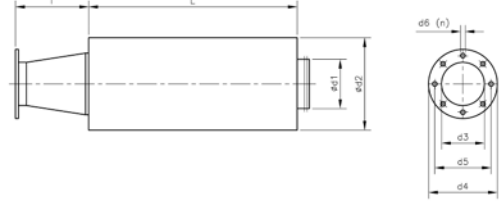

INLET

	L	d1	d2	l	d3	d4	d5	d6	n	Kg	Replacement dampers (dB) on octave band (Hz)						Applicable
											125	250	500	1000	2000	4000	
S-80/600/218-A	600	80	280	103	80	113	95	6	4x90°	6	17	26	29	53	53	45	CMA-218
S-100/600/324-A	600	100	300	108	80	130	112	6	4x90°	8	13	23	34	46	52	40	CMA-324
S-125/600/325-A	600	125	315	114	94	140	122	7	4x90°	8	11	20	30	40	45	30	CMA-325
S-150/600/426-A	600	150	355	132	117	155	132	7	4x90°	9	10	19	29	37	42	25	CMA-426
S-150/600/527-A	600	150	355	114	125	170	147	7	4x90°	9	10	19	29	37	42	25	CMA-527
S-160/600/528-A	600	160	355	107	135	190	162	7	4x90°	9	9	16	28	33	37	21	CMA-528
S-200/600/531-A	600	200	400	135	160	215	180	7	4x90°	12	6	12	22	28	28	18	CMA-531
S-250/600/540-A	600	250	450	204	170	240	205	11	4x90°	14	5	12	20	24	23	14	CMA-540
S-315/900/545-A	900	315	500	266	180	255	220	11	4x90°	22	4	12	21	26	19	15	CMA-545
S-150/600/628-A	600	150	355	100	150	200	192	7	8x45°	9	10	19	29	37	42	25	CMC-628
S-150/600/630-A	600	150	355	100	150	200	192	7	8x45°	9	10	19	29	37	42	25	CMC-630
S-200/600/835-A	600	200	400	100	200	250	230	9	8x45°	12	6	12	22	28	28	18	CMC-835
S-200/600/840-A	600	200	400	100	200	250	230	9	8x45°	12	6	12	22	28	28	18	CMC-840
S-100/600/242-A	600	100	300	115	100	150	130	10	8x45°	8	13	23	34	46	52	40	CAS/CAST-242
S-150/900/248-A	900	150	355	200	112	160	140	10	8x45°	11	10	27	37	51	53	37	CAS/CAST-248
S-160/900/254-A	900	160	355	200	125	180	155	10	8x45°	12	11	24	35	49	51	27	CAS/CAST-254
S-200/900/260-A	900	200	400	200	150	210	175	10	8x45°	17	8	18	28	40	37	23	CAS/CAST-260
S-200/900/463-A	900	200	400	200	200	260	240	10	8x45°	17	8	18	28	40	37	23	CAS/CAST-463
S-250/900/467-A	900	250	450	200	224	280	258	10	8x45°	22	6	17	30	34	28	17	CAS/CAST-467
S-250/900/571-A	900	250	450	200	250	310	275	10	8x45°	22	6	17	30	34	28	17	CAS/CAST-571
S-250/600/640-A	600	250	450	200	250	310	275	10	8x45°	14	5	12	20	24	23	14	CAS/CAST-640
S-315/900/645-A	900	315	500	200	250	310	275	10	8x45°	22	4	12	21	26	19	15	CAS/CAST-645
S-355/900/650-A	900	355	560	200	250	310	275	10	8x45°	25	4	12	20	24	18	14	CAS/CAST-650
S-180/900/680-A	900	180	380	100	165	235	200	11	8x45°	14	9	21	31	44	44	25	CAS-680
S-180/900/790-A	900	180	380	100	185	235	219	11	8x45°	14	9	21	31	44	44	25	CAS-790
S-355/900/852-A	900	355	560	200	280	350	310	10	8x45°	25	4	12	20	24	18	14	CAS/CAST-852
S-400/1200/856-A	1200	400	600	200	355	430	395	10	8x45°	38	7	16	22	29	22	15	CAS/CAST-856
S-400/1200/863-A	1200	400	600	200	355	430	410	10	8x45°	38	7	16	22	29	22	15	CAS/CAST-863
S-450/1200/971-A	1200	450	630	200	400	480	450	12	8x45°	42	6	15	21	25	20	14	CAS/CAST-971
S-250-1200/980-A	1200	250	450	100	255	325	292	11	8x45°	28	9	22	35	39	33	20	CAS-980
S-280/1200/990-A	1200	280	450	100	286	366	332	11	8x45°	32	8	18	31	38	28	19	CAS-990
S-250/1200/1080-A	1200	250	450	100	255	325	292	11	8x45°	28	9	22	35	39	33	20	CAS-1080
S-280/1200/1090-A	1200	280	450	100	286	366	332	11	8x45°	32	8	18	31	38	28	19	CAS-1090
S-500/900/1250-A	900	500	710	300	361	441	405	11,5	8x45°	56	6	13	18	15	12	CAS/CAST-1250/A	
S-560/900/1456-A	900	560	750	450	406	486	448	11,5	12x30°	65	5	8	13	11	12	8	CAS/CAST-1456/A
S-630/1200/1663-A	1200	630	800	450	568	668	629	11,5	16x22°30'	70	4	8	11	9	9	8	CAS/CAST-1663/A
S-80/600/234-A	600	80	280	108	98	130	115	5	6x60°	6	17	26	29	53	53	45	CA-234
S-100/600/142-A	600	100	300	108	90	160	130	9	4x90°	8	13	23	34	46	52	40	CA-142
S-150/900/148-A	900	150	355	149	100	170	140	9	4x90°	11	10	27	37	51	53	37	CA-148
S-160/900/154-A	900	160	355	146	115	183	155	11	4x90°	12	11	24	35	49	51	27	CA-154
S-200/900/160-A	900	200	400	183	130	230	192	11	4x90°	17	8	18	28	40	37	23	CA-160
S-200/900/166-A	900	200	400	162	140	230	200	11	4x90°	17	8	18	28	40	37	23	CA-166
S-200/900/172-A	900	200	400	149	148	230	200	11	4x90°	17	8	18	28	40	37	23	CA-172
S-250/600/540-A	600	250	450	204	170	240	205	11	4x90°	14	5	12	20	24	23	14	CAM-540
S-315/900/545-C-A	900	315	500	266	165	235	205	11	4x90°	22	4	12	21	26	19	15	CAM-545
S-355/900/550-A	900	355	560	293	210	278	258	9	6x60°	25	4	12	20	24	18	14	CAM-550
S-355/900/752-A	900	355	560	260	220	278	258	9	6x60°	25	4	12	20	24	18	14	CAM-752
S-355/1200/760-A	1200	355	560	224	246	322	280	10	6x60°	32	7	15	25	32	23	17	CAM-760
S-500/1200/880-A	1200	500	710	360	290	360	330	10	12x30°	32	7	15	25	32	23	17	CAM-880
S-315/600/922-A	600	315	500	238	220	278	256	9	8x45°	16	4	8	14	17	14	12	CMP-922
S-355/900/1025-A	900	355	560	224	245	305	282	9	8x45°	29	4	12	20	24	23	14	CMP-1025
S-400/900/1128-A	900	400	600	250	270	348	320	9	8x45°	25	5	12	19	22	18	13	CMP-1128
S-450/900/1231-A	900	450	630	291	295	382	354	9	8x45°	32	5	12	18	20	16	12	CMP-1231
S-500/900/1435-A	900	500	710	284	345	422	394	9	8x45°	35	4	11	18	16	14	11	CMP-1435
S-500/900/1640-A	900	500	710	227	395	464	438	9	8x45°	35	4	11	18	16	14	11	CMP-1640
S-560/900/1845-A	900	560	750	241	445	515	485	9	8x45°	41	4	10	16	14	13	10	CMP-1845
S-630/1200/2050-A	1200	630	800	269	495	565	535	11	8x45°	56	6	13	18	15	15	12	CMP-2050
S-800/1200/2563-A	1200	800	1000	370	595	710	675	14	8x45°	80	5	9	13	11	11	9	CMP-2563
S-400/900/1031-A	900	400	600	202	320	383	356	9	8x45°	29	5	12	19	22	18	13	CMR-1031
S-450/900/1135-A	900	450	630	216	345	425	398	9	8x45°	32	5	12	18	20	16	12	CMR-1135
S-500/900/1240-A	900	500	710	227	395	472	444	11	8x45°	35	4	11	18	16	14	11	CMR-1240
S-560/900/1445-A	900	560	750	241	445	522	494	11	8x45°	41	4	10	16	14	13	10	CMR-1445
S-630/1200/1650-A	1200	630	800	269	495	582	555	11	8x45°	56	6	13	18	15	15	12	CMR-1650
S-710/900/1856-A	900	710	900	301	555	645	615	11	8x45°	65	5	8	13	11	12	8	CMR-1856
S-800/900/2063-A	900	800	1000	329	625	720	688	11	8x45°	70	4	8	11	9	9	8	CMR-2063
S-800/1200/2271-A	1200	800	1000	224	705	800	768	13	8x45°	80	5	9	13	11	11	9	CMR-2271
S-800/1200/2380-A	1200	800	1000	224	800	906	861	13	16x22°	90	5	9	13	11	11	9	CMR-2380/CMR-X

ACCESSORIES

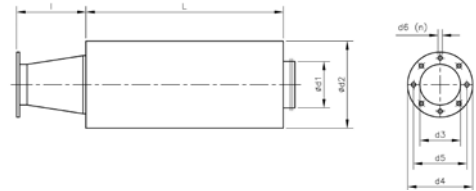

OUTLET (circular flange)

	L	d1	d2	l	d3	d4	d5	d6	n	Kg	Replacement dampers (dB) on octave band (Hz)					Applicable	
											125	250	500	1000	2000		4000
S-80/600/218-I	600	80	280	103	54	90	76	6	4x90°	6	17	26	29	53	53	45	CMA-218
S-100/600/324-I	600	100	300	131	62	110	90	7	4x90°	8	13	23	34	46	52	40	CMA-324
S-125/600/325-I	600	125	315	142	80	120	102	7	4x90°	8	11	20	30	40	45	30	CMA-325
S-150/600/426-I	600	150	355	176	90	140	119	7	4x90°	9	10	19	29	37	42	25	CMA-426
S-150/600/527-I	600	150	355	149	100	155	129	7	4x90°	9	10	19	29	37	42	25	CMA-527
S-160/600/528-I	600	160	355	138	130	190	160	11	4x90°	9	9	16	28	33	37	21	CMA-528
S-200/600/531-I	600	200	400	162	140	200	175	11	4x90°	12	6	12	22	28	28	18	CMA-531
S-250/600/540-I	600	250	450	217	150	220	190	13	4x90°	14	5	12	20	24	23	14	CMA-540
S-315/900/545-I	900	315	500	266	175	250	220	13	4x90°	22	4	12	21	26	19	15	CMA-545
S-80/600/234-I	600	80	280	103	40	100	72	9	2x180°	6	17	26	29	53	53	45	CA-234
S-100/600/142-I	600	100	300	131	60	120	90	11	4x90°	8	13	23	34	46	52	40	CA-142
S-150/900/148-I	900	150	355	176	73	150	110	11	4x90°	11	10	27	37	51	53	37	CA-148
S-160/900/154-I	900	160	355	190	80	160	120	13	4x90°	12	11	24	35	49	51	27	CA-154
S-200/900/160-I	900	200	400	245	85	160	120	13	4x90°	17	8	18	28	40	37	23	CA-160
S-200/900/166-I	900	200	400	245	85	160	120	13	4x90°	17	8	18	28	40	37	23	CA-166
S-200/900/172-I	900	200	400	245	90	175	140	13	4x90°	17	8	18	28	40	37	23	CA-172

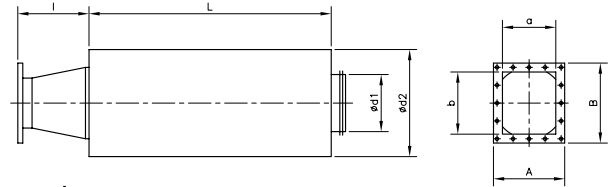

OUTLET (Rectangular flange)

	L	d1	d2	l	a	b	A	B	Kg	Replacement dampers (dB) on octave band (Hz)					Applicable	
										125	250	500	1000	2000		4000
S-150/600/628-I	600	150	355	100	86	86	130	130	9	10	19	29	37	42	25	CMC-628
S-150/600/630-I	600	150	355	100	86	86	130	130	9	10	19	29	37	42	25	CMC-630
S-200/600/835-I	600	200	400	100	91	91	141	141	12	6	12	22	28	28	18	CMC-835
S-200/600/840-I	600	200	400	100	91	91	141	141	12	6	12	22	28	28	18	CMC-840
S-100/600/242-I	600	100	300	200	95	60	155	120	8	13	23	34	46	52	40	CAS/CAST-242
S-150/900/248-I	900	150	355	200	105	66	165	126	11	10	27	37	51	53	37	CAS/CAST-248
S-160/900/254-I	900	160	355	200	115	75	175	135	12	11	24	35	49	51	27	CAS/CAST-254
S-200/900/260-I	900	200	400	200	125	85	185	145	17	8	18	28	40	37	23	CAS/CAST-260
S-200/900/463-I	900	200	400	200	125	85	185	145	17	8	18	28	40	37	23	CAS/CAST-463
S-250/900/467-I	900	250	450	250	130	90	190	150	22	6	17	30	34	28	17	CAS/CAST-467
S-250/900/571-I	900	250	450	250	145	95	205	155	22	6	17	30	34	28	17	CAS/CAST-571
S-250/600/640-I	600	250	450	250	200	125	260	185	14	5	12	20	24	23	14	CAS/CAST-640
S-315/900/645-I	900	315	500	250	224	140	284	200	22	4	12	21	26	19	15	CAS/CAST-645
S-355/900/650-I	900	355	560	250	250	160	310	220	25	4	12	20	24	18	14	CAS/CAST-650
S-180/900/680-I	600	180	380	100	71	100	131	160	15	9	21	31	44	44	25	CAS-680
S-180/900/790-I	600	180	380	100	80	112	140	172	15	9	21	31	44	44	25	CAS-790
S-355/900/852-I	900	355	560	250	280	180	340	240	25	4	12	20	24	18	14	CAS/CAST-852
S-400/1200/856-I	1200	400	600	280	280	180	340	240	38	7	16	22	29	22	15	CAS/CAST-856
S-400/1200/863-I	1200	400	600	280	315	200	375	260	38	7	16	22	29	22	15	CAS/CAST-863
S-450/1200/971-I	1200	450	630	280	355	224	425	294	42	6	15	21	25	20	14	CAS/CAST-971
S-250/1200/980-I	1200	250	450	100	140	200	210	270	29	9	22	35	39	33	20	CAS-980
S-280/1200/990-I	1200	280	450	100	160	224	230	294	33	8	18	31	38	28	19	CAS-990
S-250/1200/1080-I	1200	250	450	100	140	200	210	270	29	9	22	35	39	33	20	CAS-1080
S-280/1200/1090-I	1200	280	450	100	160	224	230	294	33	8	18	31	38	28	19	CAS-1090
S-500/900/1250-I	900	500	600	300	280	400	360	480	9	6	13	18	15	15	12	CAS/CAST-1250/A
S-560/900/1456-I	900	560	630	450	315	450	395	530	9	5	8	13	11	12	8	CAS/CAST-1456/A
S-630/1200/1663-I	1200	630	750	450	355	500	435	580	12	4	8	13	11	11	9	CAS/CAST-1663/A
S-250/600/540-C-I	600	250	450	300	140	120	224	206	14	5	12	20	24	23	14	CAM-540
S-315/900/545-C-I	900	315	500	300	170	135	255	222	22	4	12	21	26	19	15	CAM-545
S-355/900/550-I	900	355	560	300	200	150	296	246	25	4	12	20	24	18	14	CAM-550
S-355/900/752-I	900	355	560	300	200	160	296	256	25	4	12	20	24	18	14	CAM-752
S-355/1200/760-I	1200	355	560	300	220	180	316	276	32	7	15	25	32	23	17	CAM-760
S-500/1200/880-I	1200	500	710	300	290	190	360	249	32	7	15	25	32	23	17	CAM-880
S-315/600/922-I	600	315	500	300	216	140	282	204	16	4	8	14	17	14	12	CMP-922
S-355/900/1025-I	900	355	560	300	250	165	314	229	25	4	12	20	24	23	14	CMP-1025
S-400/900/1128-I	900	400	600	300	300	180	364	244	29	5	12	19	22	18	13	CMP-1128
S-450/900/1231-I	900	450	630	300	320	200	384	266	32	5	12	18	20	16	12	CMP-1231
S-500/900/1435-I	900	500	710	300	280	228	344	294	35	4	11	18	16	14	11	CMP-1435
S-500/900/1640-I	900	500	710	300	320	250	404	336	35	4	11	18	16	14	11	CMP-1640
S-560/900/1845-I	900	560	750	450	360	284	444	370	41	4	10	16	14	13	10	CMP-1845
S-630/1200/2050-I	1200	630	800	450	450	315	545	412	56	6	13	18	15	15	12	CMP-2050
S-800/1200/2563-I	1200	800	1000	450	600	410	706	512	80	5	9	13	11	11	9	CMP-2563
S-400/900/1031-I	900	400	600	300	315	250	385	320	29	5	12	19	22	18	13	CMR-1031
S-450/900/1135-I	900	450	630	450	355	280	425	350	32	5	12	18	20	16	12	CMR-1135
S-500/900/1240-I	900	500	710	450	400	315	480	395	35	4	11	18	16	14	11	CMR-1240
S-560/900/1445-I	900	560	750	450	450	355	540	445	41	4	10	16	14	13	10	CMR-1445
S-630/1200/1650-I	1200	630	800	450	500	400	590	490	56	6	13	18	15	15	12	CMR-1650
S-710/900/1856-I	900	710	900	450	560	450	660	550	65	5	8	13	11	12	8	CMR-1856
S-800/900/2063-I	900	800	1000	450	630	500	750	620	70	4	8	11	9	9	8	CMR-2063
S-800/1200/2271-I	1200	800	1000	450	710	560	840	690	80	5	9	13	11	11	9	CMR-2271
S-800/1201/2380-I	1200	800	1000	450	560	800	680	920	90	5	9	13	11	11	9	CMR-2380
S-800/1200/2380-I	1200	800	1000	450	560	1120	680	1260	90	5	9	13	11	11	9	CMR-2380-X



MOTORS

Three-phase asynchronous motors

Features:

- Speeds: 2, 4, 6 and 8 poles
- Three-phase power 230/400V 50Hz up to 5.5CV, and 400/690V 50Hz for greater power
- Form of construction IM B3 (IM 1001)
- Closed motors, with external ventilation (IC 411)
- Degree of protection IP-55
- Class F insulation
- S1 Service

On request:

- Other forms of construction
- Single-phase motors
- Two-speed motors

Regulations:

- They fulfil the following international regulations:

Electric regulations

General prescriptions on electrical machines	IEC/EN 60034-1
Marking of terminals and direction of rotation	IEC 60034-8
Start up characteristics of three-phase induction motors	IEC 60034-12
Insulating materials	IEC 60085
Standardised voltages	IEC 60038

Mechanical regulations

Dimensions and assigned power	IEC 60072
Degrees of protection (Code IP)	IEC/EN 60034-5
Methods of refrigeration	IEC/EN 60034-6
Forms of construction	IEC/EN 60034-7
Noise maximum values	IEC/EN 60034-9
Mechanical vibrations	IEC 60034-14

**3000 r/min
= 2 poles
50Hz**

Type of motor	Power (kW)	Power (CV)	Speed (r/min)
MOTOR-56 1-2T	0.09	0.12	2670
MOTOR-56 2-2T	0.12	0.16	2730
MOTOR-63 1-2T	0.18	0.25	2710
MOTOR-63 2-2T	0.25	0.33	2710
MOTOR-71 1-2T	0.37	0.5	2730
MOTOR-71 2-2T	0.55	0.75	2760
MOTOR-80 1-2T	0.75	1	2770
MOTOR-80 2-2T	1.1	1.5	2770
MOTOR-90S-2T	1.5	2	2840
MOTOR-90L-2T	2.2	3	2840
MOTOR-100L-2T	3	4	2840
MOTOR-112M-2T	4	5.5	2880
MOTOR-132S 1-2T	5.5	7.5	2900
MOTOR-132S 2-2T	7.5	10	2920
MOTOR-160M 1-2T	11	15	2940
MOTOR-160M 2-2T	15	20	2940
MOTOR-160L-2T	18.5	25	2940

**1500 r/min
= 4 poles
50Hz**

Type of motor	Power (kW)	Power (CV)	Speed (r/min)
MOTOR-56 1-4T	0.06	0.08	1320
MOTOR-56 2-4T	0.09	0.12	1320
MOTOR-63 1-4T	0.12	0.17	1350
MOTOR-63 2-4T	0.18	0.25	1350
MOTOR-71 1-4T	0.25	0.33	1350
MOTOR-71 2-4T	0.37	0.50	1370
MOTOR-80 1-4T	0.55	0.75	1370
MOTOR-80 2-4T	0.75	1.00	1380
MOTOR-90S-4T	1.10	1.50	1400
MOTOR-90L-4T	1.50	2.00	1400
MOTOR-100L-4T	2.20	3.00	1420
MOTOR-100L 2-4T	3.00	4.00	1420
MOTOR-112M-4T	4.00	5.50	1430
MOTOR-132S-4T	5.50	7.50	1450
MOTOR-132M-4T	7.50	10.00	1450
MOTOR-160M-4T	11.00	15.00	1460
MOTOR-160L-4T	15.00	20.00	1460

**1000 r/min
= 6 poles
50Hz**

Type of motor	Power (kW)	Power (CV)	Speed (r/min)
MOTOR-71 1-6T	0.18	0.25	880
MOTOR-71 2-6T	0.25	0.35	900
MOTOR-80 1-6T	0.37	0.50	900
MOTOR-80 2-6T	0.55	0.75	900
MOTOR-90S-6T	0.75	1.00	920
MOTOR-90L-6T	1.10	1.50	925
MOTOR-100L-6T	1.50	2.00	945
MOTOR-112M-6T	2.20	3.00	955
MOTOR-132S-6T	3.00	4.00	960
MOTOR-132M 1-6T	4.00	5.50	960
MOTOR-132M 2-6T	5.50	7.50	960
MOTOR-160M-6T	7.50	10.00	970
MOTOR-160L-6T	11.00	15.00	970

**750 r/min
= 8 poles
50Hz**

Type of motor	Power (kW)	Power (CV)	Speed (r/min)
MOTOR-80 1-8T	0.18	0.25	680
MOTOR-80 2-8T	0.25	0.33	680
MOTOR-90S-8T	0.37	0.50	680
MOTOR-90L-8T	0.55	0.75	680
MOTOR-100L-8T	0.75	1.00	710
MOTOR-100L 2-8T	1.10	1.50	710
MOTOR-112M-8T	1.50	2.00	710
MOTOR-132S-8T	2.20	3.00	720
MOTOR-132M-8T	3.00	4.00	720
MOTOR-160M 1-8T	4.00	5.50	720
MOTOR-160M 2-8T	5.50	7.50	720
MOTOR-160L-8T	7.50	10.00	720

Wiring diagram

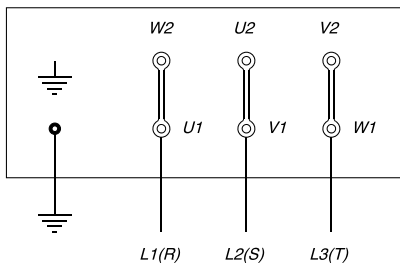

△
Low voltage

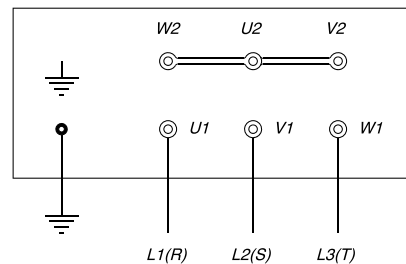

Y
High voltage

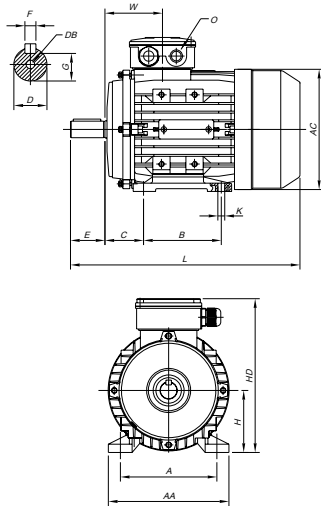

Measurements

Model	H	A	B	C	D	E	F	G	DB	K	AA	HD	AC	L	O
56	56	90	71	36	9	20	3	7.2	M3	6x8.8	110	160	120	195	1-M16X1.5
63	63	100	80	40	11	23	4	8.5	M4	6x10	120	165	130	215	1-M16X1.5
71	71	112	90	45	14	30	5	11	M5	7x10	132	180	145	245	1-M20X1.5
80	80	125	100	50	19	40	6	15.5	M6	10x13	160	217	165	290	1-M20X1.5
90S	90	140	100	56	24	50	8	20	M8	10x13	175	230	185	310	1-M20X1.5
90L1/L2	90	140	125	56	24	50	8	20	M8	10x13	175	235	185	335/365	1-M20X1.5
100	100	160	140	63	28	60	8	24	M10	12x16	196	252	205	386	1-M20X1.5
112	112	190	140	70	28	60	8	24	M10	12x16	220	292	230	395	2-M25X1.5
132/S	132	216	140	89	38	80	10	33	M12	12x16	252	330	270	436	2-M25X1.5
132M/L	132	216	178	89	38	80	10	33	M12	12x16	252	325	270	475/500	2-M25X1.5
160M	160	254	210	108	42	110	12	37	M16	15x19	335	390	320	640	2-M32X1.5
160L	160	254	254	108	42	110	12	37	M16	15x19	335	390	320	640	2-M32X1.5

Grilles for extraction and impulsion air outlets for single-family or community housing.

Circular design.

Circular ventilation openings for extraction or incorporation of air, manufactured in plastic material or sheet steel painted according to model, designed for installation in the CJT-3C and CJP-3C boxes



BE-RP

Extraction outlets that are manually regulated by means of a central screw in plastic material

- In order to install in built-in boxes it is necessary to have a hose with joints

Model	Maximum Airflow (m³/h)
BE-RP-80	15/90
BE-RP-100	20/120
BE-RP-125	30/180
BE-RP-160	40/220
BE-RP-200	50/250
Hose Ø100 with joint	-
Hose Ø125 with joint	-



BE-ALIZE

Self-regulable extraction openings which guarantee a constant extraction of air

- S version: Fixed flow of extraction, for bathrooms.
- C version: Permanent extraction flow, completed by a complementary extraction flow, activated by means of a cord, for kitchens or locations where modulation of the extracted flow is needed
- In order to install in built-in boxes it is necessary to have a hose with joints

Model	Maximum Airflow (m³/h)
BE-ALIZE-S-15	15
BE-ALIZE-S-30	30
BE-ALIZE-S-45	45
BE-ALIZE-S-60	60
BE-ALIZE-S-75	75
BE-ALIZE-S-90	90
BE-ALIZE-S-120	120
BE-ALIZE-S-150	150
BE-ALIZE-C-20/75	20/75
BE-ALIZE-C-30/90	30/90
BE-ALIZE-C-45/105	45/105
BE-ALIZE-C-45/120	45/120
BE-ALIZE-C-45/135	45/135
Hose Ø125 with joint	-
Hose p/pladur Ø125	-
Hose p/pladur Ø125/80	-
Acoustic module	-



BE-ALIZE-HVT

Self-regulable extraction openings which guarantee a constant extraction of air as a function of the humidity or by a detector of human

- H version: Extraction flow moisture-regulable between 6 and 90m³/h or 10 and 135 m³/h, as a function of the relative humidity. Permanent extraction flow of 6 or 10 m³/h, depending on the version.
- V version: Possibility of adjustment up to a maximum flow of 30m³/h and the operation time adjustable up to 30 minutes. It works when it detects human presence on the premises. Permanent extraction flow of 5m³/h.
- T version: Possibility of adjustment up to a maximum flow of 30m³/h and the operation time adjustable up to 30 minutes. It starts to operate when the light is switched on. Permanent extraction flow of 5m³/h.
- Hose for installation included

Model	Maximum Airflow (m³/h)
BE-ALIZE-H-6/40/90	5/90
BE-ALIZE-H-10/45/105	10/105
BE-ALIZE-H-10/45/135	10/135
BE-ALIZE-V-5/30	5/30
BE-ALIZE-T-5/30	5/30
Hose p/pladur Ø125/HTV	-
Hose p/pladur Ø125/80/HTV	-



BE-AC

Extraction outlets that are manually regulated by means of a central screw in painted sheet steel

- Hose for installation included

Model	Maximum Airflow (m ³ /h)
BE-AC-100	10/120
BE-AC-125	20/180
BE-AC-160	20/280
BE-AC-200	30/350



BI-RP

Outlets that are manually regulated by means of a central screw in plastic material

- In order to install in built-in boxes it is necessary to have a hose with joints

Model	Maximum Airflow (m ³ /h)
BI-RP-100	15/180
BI-RP-125	15/220
BI-RP-160	50/400
BI-RP-200	50/500
Hose Ø100 with joint	-
Hose Ø125 with joint	-



BI-AC

Outlets that are manually regulated by means of a central screw in painted sheet steel

- Hose for installation included

Model	Maximum Airflow (m ³ /h)
BI-AC-100	15/180
BI-AC-125	15/220
BI-AC-160	50/400
BI-AC-200	50/500



RC

Circular grilles in plastic material for mounting on the exterior of houses and apartments

Model	Ext. measurements	For hole with
RC-100/B	106 mm	40 to 80 mm
RC-125/B	155 mm	80 to 125 mm
RC-150/B	175 mm	125 to 160 mm
RC-200/B	235 mm	165 to 220 mm
RC-250/B	270 mm	220 to 260 mm



RCC

Circular constant flow regulator with hose and self-regulable system composed of a hatch and a regulatory spring which enables to maintain a constant flow with pressure variations of between 50 and 200 Pa

Model	Airflow (m ³ /h)	Duct (mm)
RCC-80/15	15	80
RCC-80/30	30	80
RCC-80/45	45	80
RCC-100/15	15	100
RCC-100/30	30	100
RCC-100/45	45	100
RCC-100/60	60	100
RCC-100/75	75	100
RCC-100/90	90	100
RCC-125/15	15	125
RCC-125/30	30	125
RCC-125/45	45	125
RCC-125/60	60	125

Model	Airflow (m ³ /h)	Duct (mm)
RCC-125/75	75	125
RCC-125/90	90	125
RCC-125/120	120	125
RCC-125/150	150	125
RCC-125/180	180	125
RCC-160/120	120	160
RCC-160/150	150	160
RCC-160/180	180	160
RCC-160/210	210	160
RCC-160/240	240	160
RCC-160/270	270	160
RCC-160/300	300	160
RCC-200/210	210	200

Model	Airflow (m ³ /h)	Duct (mm)
RCC-200/240	240	200
RCC-200/270	270	200
RCC-200/300	300	200
RCC-200/350	350	200
RCC-200/400	400	200
RCC-200/450	450	200
RCC-200/500	500	200
RCC-250/350	350	250
RCC-250/500	500	250
RCC-250/550	550	250
RCC-250/600	600	250
RCC-250/650	650	250
RCC-250/700	700	250

Air intakes for single-family or community housing

Ventilators which guarantee the renewal of the air in the main rooms of a house through the facade. Incorporates an anti-insect cover. Made from white plastic material.

EA



Self-regulable air inlets, including a diffuser and external cover on the facade

- The EA-15, EA-22 and EA-30 models are valid for holes A and B. The EA-45 model is valid for hole B.

Dimensions hole A (mm)

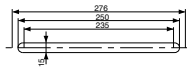

Dimensions hole B (mm)

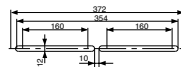

Model	Maximum Airflow (m³/h)
EA-15	15
EA-22	22
EA-30	30
EA-45	45

EA-A



Acoustic and self-regulable air inlets, including a diffuser and external cover on the facade with noise reduction

- The EA-A-2.22 and EA-A-2.30 models are valid for holes A and B. The EA-A-2.45 model is valid for hole B.

Dimensions hole A (mm)

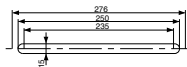

Dimensions hole B (mm)

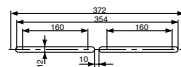

Model	Maximum Airflow (m³/h)
EA-A-2.22-RA	22
EA-A-2.30-RA	30
EA-A-2.45-RA	45

EA-A-HY



Acoustic and moisture-regulable air inlets between 7 and 40 m³/h depending on the degree of humidity in the premises with noise reduction including a diffuser and external cover on the facade

Dimensions hole (mm)

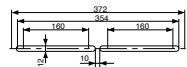

Model	Maximum Airflow (m³/h)
EA-A-HY-7.40-RA	7/40

EA-STM



Silencer with wall bushings for the self-regulable and moisture-regulable air inlets. It is placed after having perforated the wall and a PVC hose with a diameter of 125mm is built in

Model	Maximum Airflow (m³/h)
EA-STM	30/45
MAC-30	30
MAC-45	45

Intelligent sensors for controlling the fans



Sensors which make it possible to sense certain environmental conditions and automatically start up the fans. This enables to use the ventilation only when necessary. Using the sensors with the frequency inverters we can control the regime of operation of the fans, thus preventing the fan always working at its maximum consumption. These systems involve a significant energy saving.



SI-PIR-TF-Cenital



SI-PIR-TF-Mural

SI-PIR

Motion detector

Automatically activates the ventilation system when it detects the presence of people within its radius of action and keeps functioning for a pre-set time, which can be adjusted by means of an internal clock

Model	Power	Output	Detection angle	Adjustments	Height installation	Working temperature
SI-PIR	230V	230V	360°C	Timing 5s-30 min	2.4-4.2 m	-20°C +50°C
SI-PIR-TFT-550-B	24V ac/24V dc	24V ac/24V dc	110°C	Timing 5s-30 min	1.8-3.6 m	-20°C +50°C
SI-PIR-TF-25-360	24V ac/24V dc	24V ac/24V dc	360°C	Timing 10s-30 min	2.4-4.2 m	-20°C +50°C



SI-SMOKE

Tobacco smoke detector

Automatically activates the ventilation system when tobacco smoke and other contaminants exceed the pre-set value in the sensor and keeps functioning for a pre-set time, which can be adjusted by means of an internal clock

Model	Power	Output	Maximum intensity (A)	Adjustments	Height installation	Working temperature
SI-SMOKE	220-240V ac	220-240V ac	3.0	Timing 3min-20 min	1.5-2.0 m	-20°C +50°C



SI-CO2

Air quality detector

Automatically activates the ventilation system when the increase in contamination, as a function of the occupation of the premises, exceeds the pre-set value

Model	Power	Output	Consumption (W)	Adjustments	Height installation	Working temperature
SI-CO2-GAQ24	24V ac	0-10V ac	5	Timing 10s-30 min	1.5-2.5 m	-20°C +50°C



SI-TEMP

Temperature sensor

Automatically activates the ventilation system when it detects a temperature greater than the pre-set value. Once the environmental temperature has descended below the pre-set point, the fan remains functioning for a pre-set period, which can be adjusted by means of the internal clock. The range of temperature oscillates between +10°C and 40°C

Model	Power	Output	Maximum intensity (A)	Adjustments	Height installation	Working temperature
SI-TEMP	220-240V ac	220-240V ac	3.0	Timing 3min-20 min	1.5-2.0 m	+10°C +40°C



SI-TEMP+HUMEDAD

Temperature and relative humidity sensor with display

Independently controls the temperature and the relative humidity of the air on the premises. Automatically activates the ventilation system when it detects a temperature or humidity greater than the pre-set value. Once the environmental temperature or humidity has descended below the pre-set point, the fan remains functioning for a pre-set period, which can be adjusted by means of the internal clock.

Model	Power	Output	Adjustments	Height installation	Working temperature
SI-TEMP+HUMEDAD	24V ac	0-10V dc	$\Delta T = 0.5^{\circ}\text{C}$ and $\Delta \text{HR} = 2\%$	1.5-2.5 m	+10° +40° C



SI-PRESIÓN

Pressure transmission unit

Controls the pressure in facilities with constant pressure ventilation, and transforms it into an electrical signal to regulate the ventilation system and constantly maintain the same pressure

Model	Power	Output	Maximum consumption (VA)	Ø Connectors	Pressure range
SI-PRESIÓN TPDA-3202	24V ac/24V dc	0-10V/4-20mA	4	6.2 mm	0-2500 Pa
SI-PRESIÓN TPDA-3202 c/DISPLAY	24V ac/24V dc	0-10V/4-20mA	4	6.2 mm	0-2500 Pa



SI-TIMER

Timer

Adjusts the operating time of the ventilation system to which it is connected. The ventilation system is automatically activated when the light switch goes on and continues to function for a pre-set time which can be altered by means of the internal clock

Model	Power	Output	Maximum intensity (A)	Adjustments	Working temperature
SI-TIMER	220-240V ac	220-240V dc	3.0	Timing 3min-20 min	-20°C +50°C



SI-FUENTE DE ALIMENTACIÓN ac



SI-FUENTE DE ALIMENTACIÓN dc

SI-FUENTE DE ALIMENTACIÓN

Power supply 24V dc / ac

Powers the intelligent 24V dc/ac sensors from an input voltage of 230V. single-phase

Model	Power	Output	Power (VA)
SI-FUENTE DE ALIMENTACIÓN dc	230 V	24V dc	30
SI-FUENTE DE ALIMENTACIÓN ac	230/400 V	24/48V ac	25

OUR PRODUCTS

In-line duct fans



Axial fans



Centrifugal fans



Fans for smoke extraction
400°C/2h - 300°C/1h



ATEX Fans for explosive atmospheres



Roof fans



Ventilation systems
for houses



Heat recovery units



Filtration units



Air curtains



Efficient Energy Applications



Ask us for
information

Ventilation software.
General catalogue



Crta. de Berga, km 0.7
E-08580 SANT QUIRZE DE BESORA
Barcelona - SPAIN
Tel. +34 93 852 91 11
Fax +34 93 852 90 42
comercial@sodeca.com
Export sales: ventilation@sodeca.com
www.sodeca.com



Export sales

SODECA EXPORT

Crta. de Berga, km 0.7
E-08580 SANT QUIRZE
DE BESORA
Barcelona - SPAIN
Tel. +34 93 852 91 11
Fax +34 93 852 90 42
ventilation@sodeca.com

PORTUGAL

Mr. Albert Bartés
E-08580 SANT QUIRZE DE BESORA
Barcelona - SPAIN
Tel. +34 93 852 91 11
Fax +34 93 852 90 42
comercial@sodeca.com

SODECA SOUTH AMERICA

Sodeca Ventiladores Ltda
Avda. Puerta Sur 03380
San Bernardo, SANTIAGO, CHILE
ventilation@sodeca.com

SODECA CARIBBEAN AREA

Mr. Carlos A. Hernández Gil
Residencial Miramar N° 120B-7ma Ave. N° 1805
entre 18 y 20.
Miramar Playa, CIUDAD DE LA HABANA, CUBA
Tel. 00537 20 43721
sodeca@enet.cu



Crta. de Berga, km 0.7
E-08580 SANT QUIRZE DE BESORA
(Barcelona - Spain)
Tel. +34 93 852 91 11
Fax +34 93 852 90 42
comercial@sodeca.com
Export sales: ventilation@sodeca.com

www.sodeca.com

