

CMR

Robust centrifugal single-inlet, medium-pressure fans fitted with an impeller with backward-facing blades



CMR



CMR
Size 622 to 731

Fan:

- Steel sheet casing
- Impeller with backward-curved blades made from robust sheet steel

Motor:

- Motors with IE-2 efficiency, except for motors with lower powers than 0.75 kW, monophase motors or two-speed motors
- Class F motors with ball bearings, IP55 protection
- Three-phase 230/400V.-50Hz. (up to 5.5CV.) and 400/690V.-50Hz. (power over 5.5CV.)
- Max. air temperature to transport: -20°C.+ 120°C.

Finish:

- Anticorrosive finish in polyester resin, polymerised at 190°C, after alkaline degreasing and phosphate-free pre-treatment.

On request:

- Special windings for different voltages.
- Fan designed to transport air up to 250°C.
- Stainless steel fans
- ATEX Certification, category 2 (see CMR/ATEX series)



Different assembly positions



High-performance and robust backward-curved impeller.

Order code

CMR — 1650 — 2T

CMR: Centrifugal single-inlet, medium-pressure fans

Impeller size

Number of motor poles

- 2=2900 r/min. 50 Hz
- 4=1400 r/min. 50 Hz
- 6=900 r/min. 50 Hz
- 8=750 r/min. 50 Hz

T=Three-phase

Technical characteristics

Model	Speed (r/min)	Maximum admissible current (A)			Installed Power (kW)	Maximum Airflow (m³/h)	Sound pressure level dB(A)	Approx. weight (Kg)
		230V	400V	690V				
CMR-622-2T	2930	1.23	0.71		0.25	1040	74	11.6
CMR-625-2T	2930	1.67	0.97		0.33	1280	75	13.7
CMR-728-2T	2930	2.45	1.42		0.50	1800	76	17.6
CMR-731-2T	2930	3.06	1.77		0.75	2350	77	22.8
CMR-1031-2T	2900	5.63	3.25		1.50	5160	80	44.3
CMR-1135-2T	2900	7.88	4.55		2.20	7800	83	54.9
CMR-1240-2T	2895	13.51	7.80		4.00	11100	86	93.5
CMR-1240-4T	1455	3.22	1.86		0.75	5800	71	70.5
CMR-1445-2T	2915		13.90	8.00	7.50	16500	87	126.0
CMR-1445-4T	1460	4.42	2.55		1.10	8030	72	92.5
CMR-1650-2T	2910		20.00	11.50	11.00	18850	89	178.0
CMR-1650-4T	1440	5.89	3.40		1.50	10500	74	114.0
CMR-1650-6T	970	3.91	2.26		0.75	7410	64	114.0
CMR-1856-4T	1455	11.09	6.40		3.00	15150	79	152.0
CMR-1856-6T	965	5.04	2.90		1.10	10050	70	146.5
CMR-2063-4T	1460		11.40	6.60	5.50	24450	80	226.0
CMR-2063-6T	935	7.48	4.30		1.50	16100	71	208.5

Technical characteristics

Model	Speed (r/min)	Maximum admissible current (A)			Installed Power (kW)	Maximum Airflow (m³/h)	Sound pressure level dB(A)	Approx. weight (Kg)
		230V	400V	690V				
CMR-2063-8T	725	5.90	3.39		1.10	11600	65	210.5
CMR-2271-4T	1465		21.50	12.40	11.00	34610	85	315.0
CMR-2271-6T	950	12.20	6.82		3.00	22750	76	293.5
CMR-2271-8T	720	7.10	4.08		1.50	17360	69	275.5
CMR-2380-4T	1400		41.00	23.70	22.00	48000	83	416.0
CMR-2380-6T	900		15.40	8.90	7.50	30000	75	363.0
CMR-2380-8T	700	12.80	7.38		3.00	22000	66	317.0
CMR-2590-4T	1475		68.00	39.30	37.00	54000	86	418.0
CMR-2590-6T	970		23.00	13.30	11.00	34000	76	378.0
CMR-28100-4T	1475		98.00	56.60	55.00	75000	87	553.0
CMR-28100-6T	985		36.00	20.80	18.50	48000	77	521.0

Acoustic features

The specified values are determined according to free field measurements of pressure and sound levels in dB(A) at an equivalent distance of twice the fan's span plus the turbine's diameter, with a minimum of 1.5 m.

Sound power Lw(A) spectrum in dB(A) via frequency band in Hz.

Model	63	125	250	500	1000	2000	4000	8000	Model	63	125	250	500	1000	2000	4000	8000
622-2T	59	72	72	85	80	80	80	73	1856-6	61	69	81	83	80	81	71	60
625-2T	60	73	73	86	81	81	81	74	2063-4	80	85	91	93	91	88	81	73
728-2T	61	74	74	87	82	82	82	75	2063-6	69	70	82	82	81	83	73	63
731-2T	62	75	75	88	83	83	83	76	2063-8	64	70	77	76	77	74	66	57
1031-2	65	78	78	91	86	86	86	79	2271-4	83	84	93	96	98	99	95	82
1135-2	72	79	77	89	87	93	92	79	2271-6	73	73	87	86	90	90	79	68
1240-2	68	83	81	93	90	94	96	83	2271-8	68	73	78	85	81	80	70	59
1240-4	56	70	76	79	79	80	70	59	2380-4	76	78	94	91	96	97	93	82
1445-2	73	85	83	95	93	97	99	89	2380-6	68	70	86	83	88	89	85	74
1445-4	59	72	78	83	80	83	78	64	2380-8	59	61	77	74	79	80	76	65
1650-2	73	81	85	99	97	99	99	88	2590-4	79	84	97	100	96	89	84	66
1650-4	64	74	82	84	83	85	76	66	2590-6	70	79	89	88	85	84	74	68
1650-6	53	65	72	77	73	69	62	54	28100-4	82	89	101	102	97	93	87	78
1856-4	69	78	91	87	90	91	85	71	28100-6	73	82	91	90	88	86	77	70

Dimensions in mm

CMR-622...731

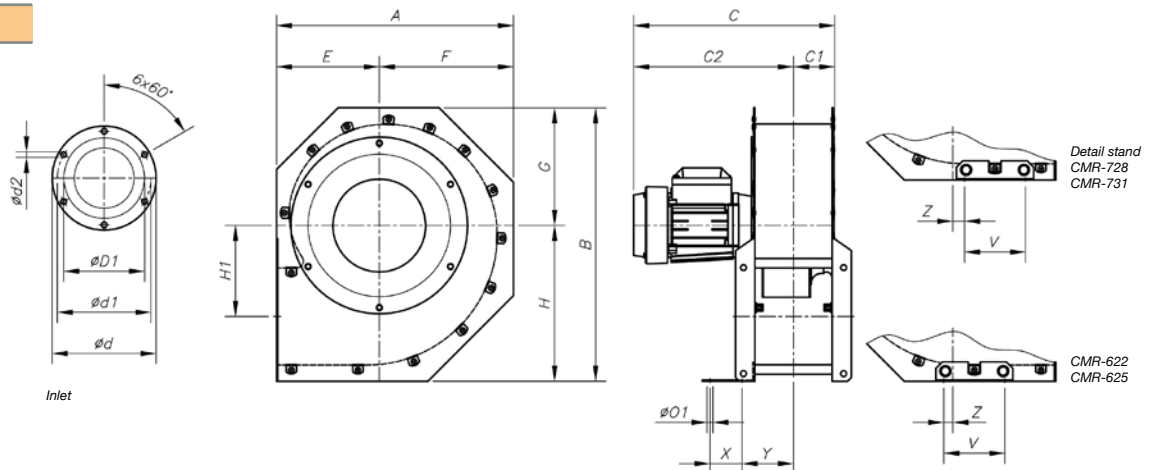

Model	A	B	C	C1	C2	øD1*	ød	ød1	ød2	E	F	G	H	H1	øO1	V	X	Y	Z
CMR-622-2T	364	415.5	338.5	64	274.5	162	284	256	9.5	160	204	178	237.5	141.5	9	95	50	80	14
CMR-625-2T	407	457	343.5	66.5	277	160	315	282	9.5	183	224	195.5	261.5	155	9	95	50	82.5	6
CMR-728-2T	453.5	506.5	357.5	72.5	285	192	354	320	9.5	205	248.5	216	290.5	176	9	95	50	88.2	6.5
CMR-731-2T	507	564	374	70	304	192	382	354	9.5	230	277	240.5	323.5	197.5	9	95	50	85.2	20.5

* Recommended nominal diameter for duct.

Dimensions in mm

CMR-1031...2271

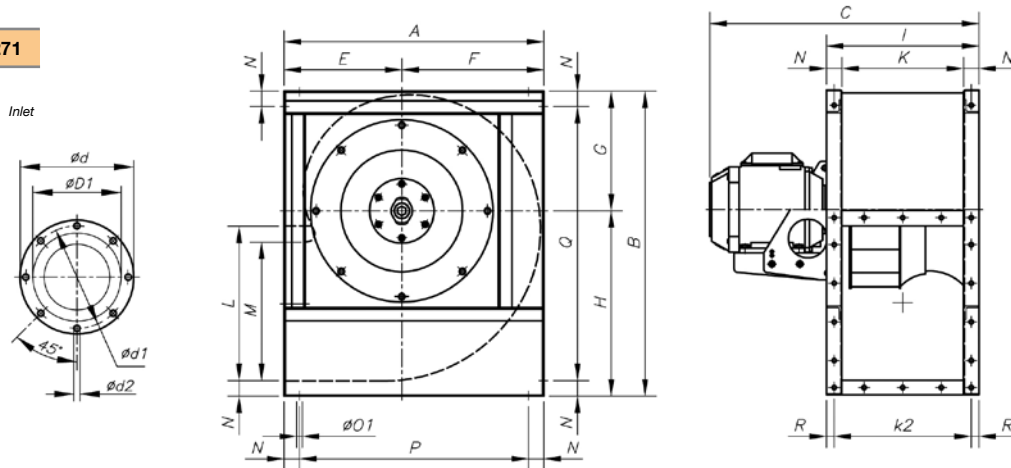

Model	A	B	C	$\phi D1^*$	ϕd	$\phi d1$	$\phi d2$	E	F	G	H	I	K	k2	L	M	N	$\phi O1$	P	Q	R
CMR-1031-2T	542	626	567	315	383	356	M8	250	292	245	381	320	250	285	315	276	35	11	472	556	17.5
CMR-1135-2T	600	696	583	355	425	398	M8	275	325	273	423	350	280	315	355	310	35	11	530	626	17.5
CMR-1240-2T	673	790	728	400	472	444	M10	305	368	310	480	395	315	355	400	358	40	11	593	710	20
CMR-1240-4T	673	790	590	400	472	444	M10	305	368	310	480	395	315	355	400	358	40	11	593	710	20
CMR-1445-2T	765	880	810	450	522	494	M10	350	415	339	541	445	355	405	450	404	45	11	675	790	20
CMR-1445-4T	765	880	649	450	522	494	M10	350	415	339	541	445	355	405	450	404	45	11	675	790	20
CMR-1650-2T	832	970	961	500	582	555	M10	375	457	378	592	490	400	450	500	445	45	13	742	880	20
CMR-1650-4T	832	970	715	500	582	555	M10	375	457	378	592	490	400	450	500	445	45	13	742	880	20
CMR-1650-6T	832	970	695	500	582	555	M10	375	457	378	592	490	400	450	500	445	45	13	742	880	20
CMR-1856-4T	925	1084	832	560	645	615	M10	415	510	426	658	550	450	500	560	493	50	13	825	984	25
CMR-1856-6T	925	1084	771	560	645	615	M10	415	510	426	658	550	450	500	560	493	50	13	825	984	25
CMR-2063-4T	1037	1218	973	630	720	688	M10	465	572	477	741	620	500	560	630	530	60	13	917	1098	30
CMR-2063-6T	1037	1218	893	630	720	688	M10	465	572	477	741	620	500	560	630	530	60	13	917	1098	30
CMR-2063-8T	1037	1218	893	630	720	688	M10	465	572	477	741	620	500	560	630	530	60	13	917	1098	30
CMR-2271-4T	1173	1375	1126	710	800	768	M12	525	648	538	837	690	560	625	710	603	65	13	1043	1245	32.5
CMR-2271-6T	1173	1375	1039	710	800	768	M12	525	648	538	837	690	560	625	710	603	65	13	1043	1245	32.5
CMR-2271-8T	1173	1375	1002	710	800	768	M12	525	648	538	837	690	560	625	710	603	65	13	1043	1245	32.5

* Recommended nominal diameter for duct.

CMR-2380...28100

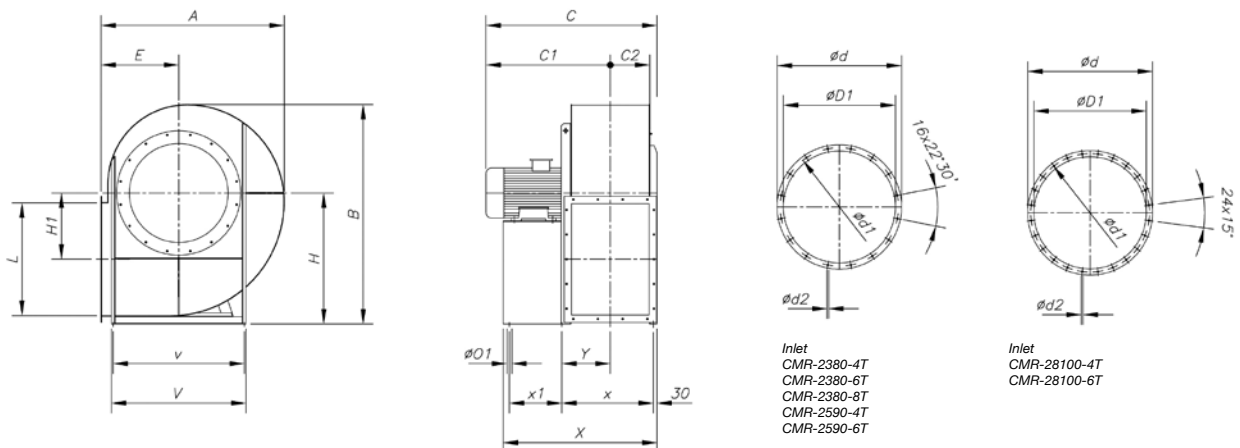

Inlet
CMR-2380-4T
CMR-2380-6T
CMR-2380-8T
CMR-2590-4T
CMR-2590-6T

Inlet
CMR-28100-4T
CMR-28100-6T

Model	A	B	C	C1	C2	$\phi D1^*$	ϕd	$\phi d1$	$\phi d2$	E	H	H1	L	$\phi O1$	V	v	X	x	x1	Y
CMR-2380-4T	1350	1660	1245	899	286	808	906	861	11.5	560	1000	500	800	17	930	870	1102.5	667.5	370	352.5
CMR-2380-6T	1350	1660	1030	744	286	808	906	861	11.5	56	1000	500	800	17	930	870	1102.5	667.5	370	352.5
CMR-2380-8T	1350	1660	1035	681	286	808	906	861	11.5	560	1000	500	800	17	930	870	1102.5	667.5	370	352.5
CMR-2590-4T	1495	1785	1390	1012	321	908	1008	958	14	630	1060	535	900	19	1030	970	1246	425	751	393
CMR-2590-6T	1495	1785	1235	857	321	908	1008	958	14	630	1060	535	900	19	1030	970	1121	340	721	373
CMR-28100-4T	1680	1990	1470	1051	362	1008	1108	1067	14	710	1180	610	1000	19	1130	1060	1378	460	843	454
CMR-28100-6T	1680	1990	1395	976	362	1008	1108	1067	14	710	1180	610	1000	19	1130	1060	1278	385	823	434

* Recommended nominal diameter for duct.

Dimensions in mm

Outlet	CMR-1031 CMR-1135 CMR-2590 CMR-28100	CMR-622 CMR-625 CMR-728 CMR-731	CMR-1240 CMR-1445 CMR-1650	CMR-1856	CMR-2063	CMR-2271	CMR-2380				
Model	I	J	J1	J2	K	k	k1	k2	L	ø0	S
CMR-622	180	191.5	-	165	120	-	-	156	150	9	12
CMR-625	185	207.5	-	181.5	125	-	-	161	167.5	9	12
CMR-728	196.5	234.5	-	202	136.5	-	-	172.5	187.5	9	12
CMR-731	190.5	250.5	-	227.5	130.5	-	-	166.5	211	9	12
CMR-1031	320	385	75	350	250	100	92.5	285	315	11	-
CMR-1135	350	425	95	390	280	100	107.5	315	355	11	-
CMR-1240	395	480	70	440	315	100	77.5	355	400	11	-
CMR-1445	445	540	99	498	355	100	102.5	405	450	11	-
CMR-1650	490	590	87.5	550	400	125	100	450	500	13	-
CMR-1856	550	660	55	610	450	125	125	500	560	13	-
CMR-2063	620	750	95	690	500	125	92.5	560	630	13	-
CMR-2271	690	840	75	775	560	125	62.5	625	710	13	-
CMR-2380	680	920	160	871	560	200	140	639	800	14	-
CMR-2590	750	1020	84	968	630	200	54	708	900	14	-
CMR-28100	830	1120	138.5	1077	710	200	92.5	785	1000	14	-

Characteristic Curves

Q = Airflow in m³/h, m³/s and cfm.

Pe = Static pressure in mm.w.c., Pa and in wg.

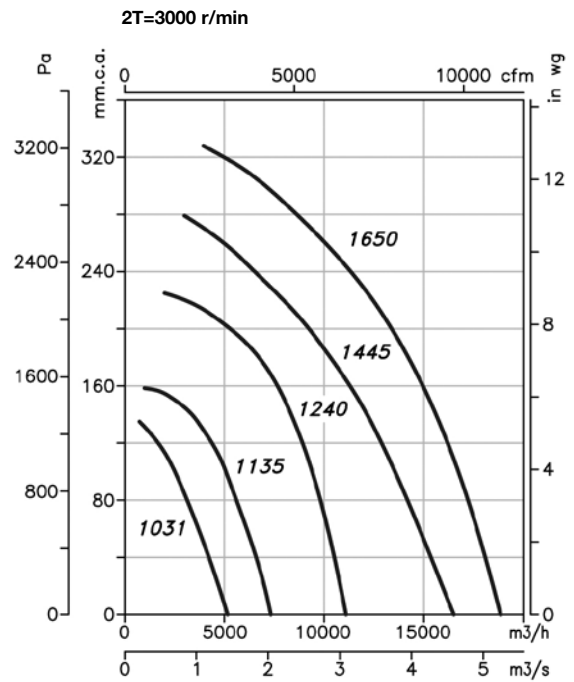
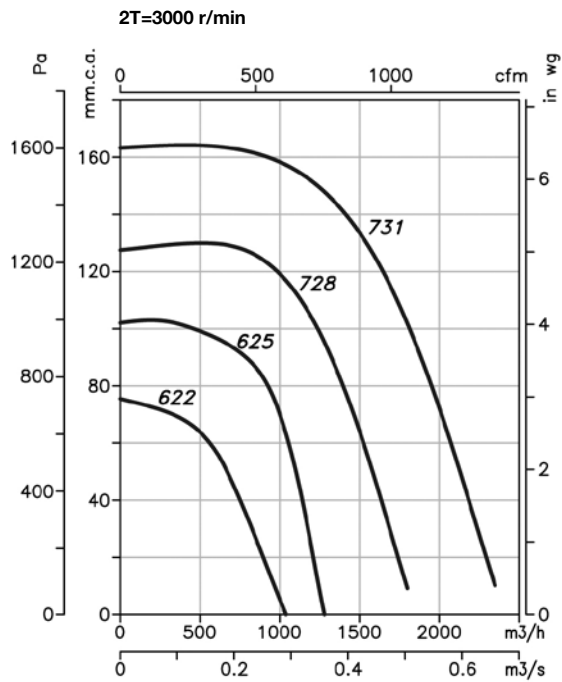

Characteristic Curves

Q = Airflow in m³/h, m³/s and cfm.

Pe = Static pressure in mm.w.c., Pa and in wg.

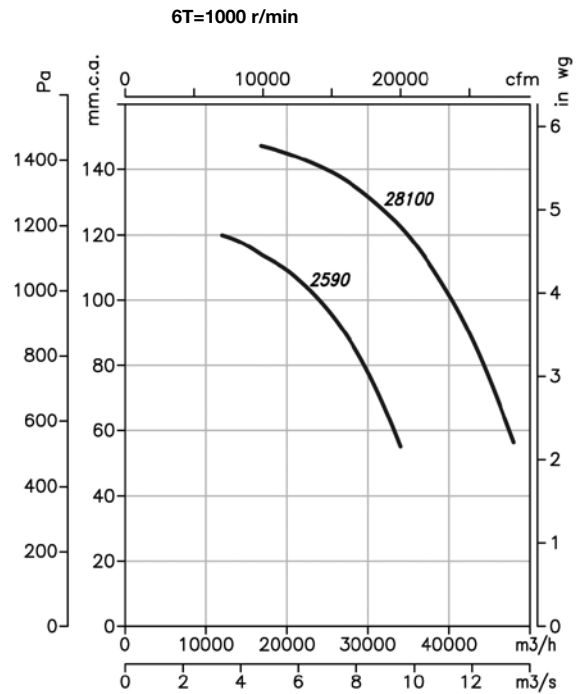
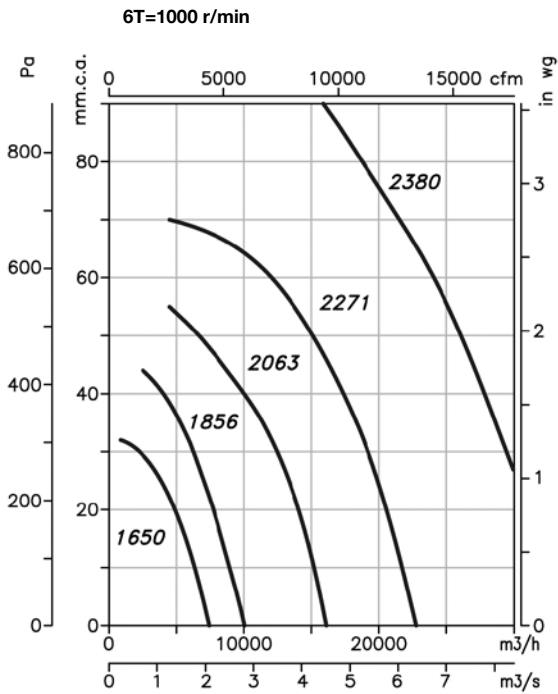
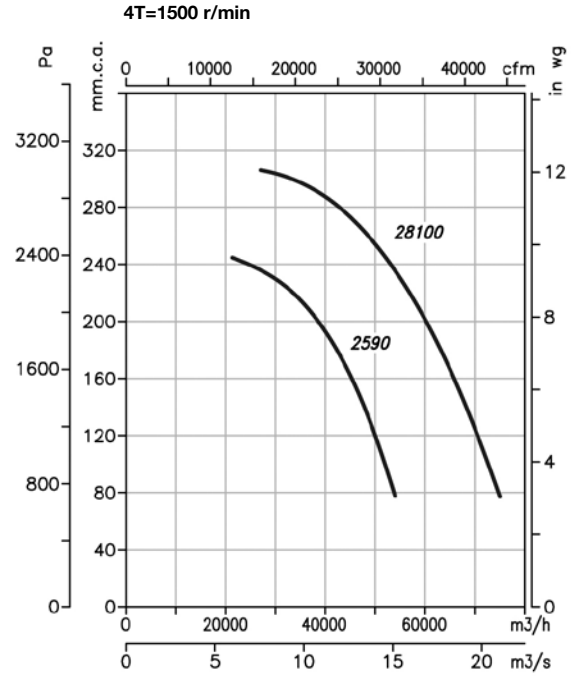
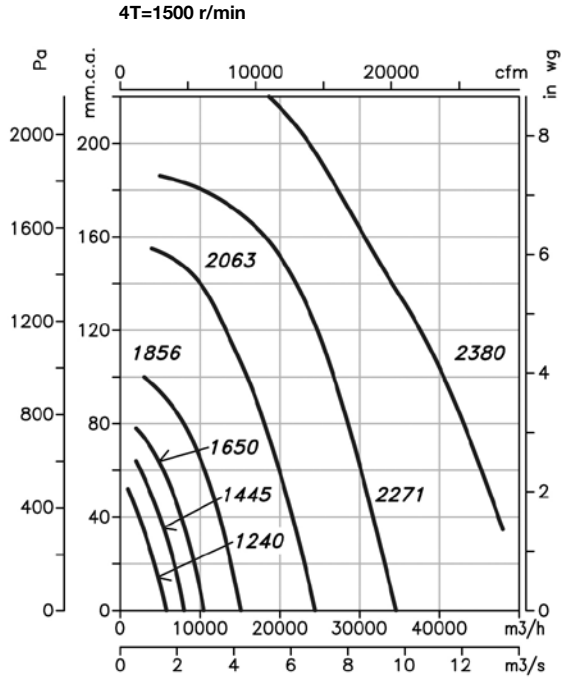

Characteristic Curves

Q = Airflow in m³/h, m³/s and cfm.

Pe= Static pressure in mm.w.c., Pa and in wg.

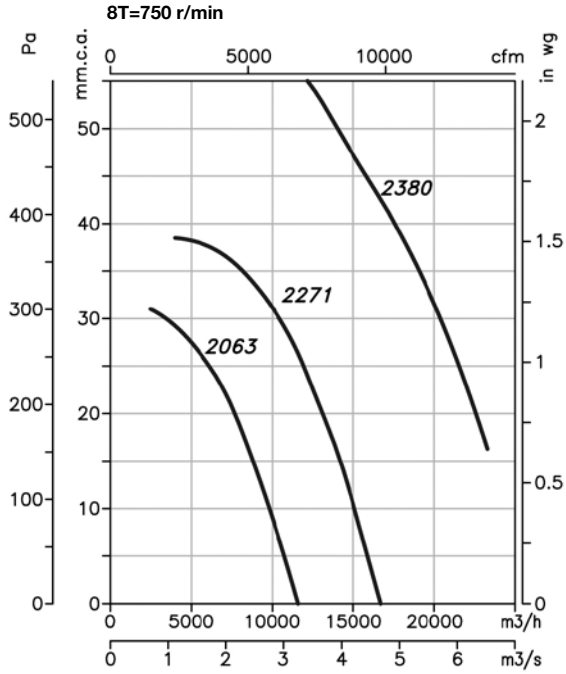

Positions

LG 270 standard supply

Models 2380, 2590 and 28100 fixed position LG 270 (other positions only on request)

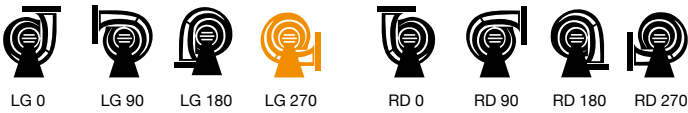

Accessories

See the accessories section.

