

Serie doble aspiración

Double inlet series

Série double aspiration

TDA

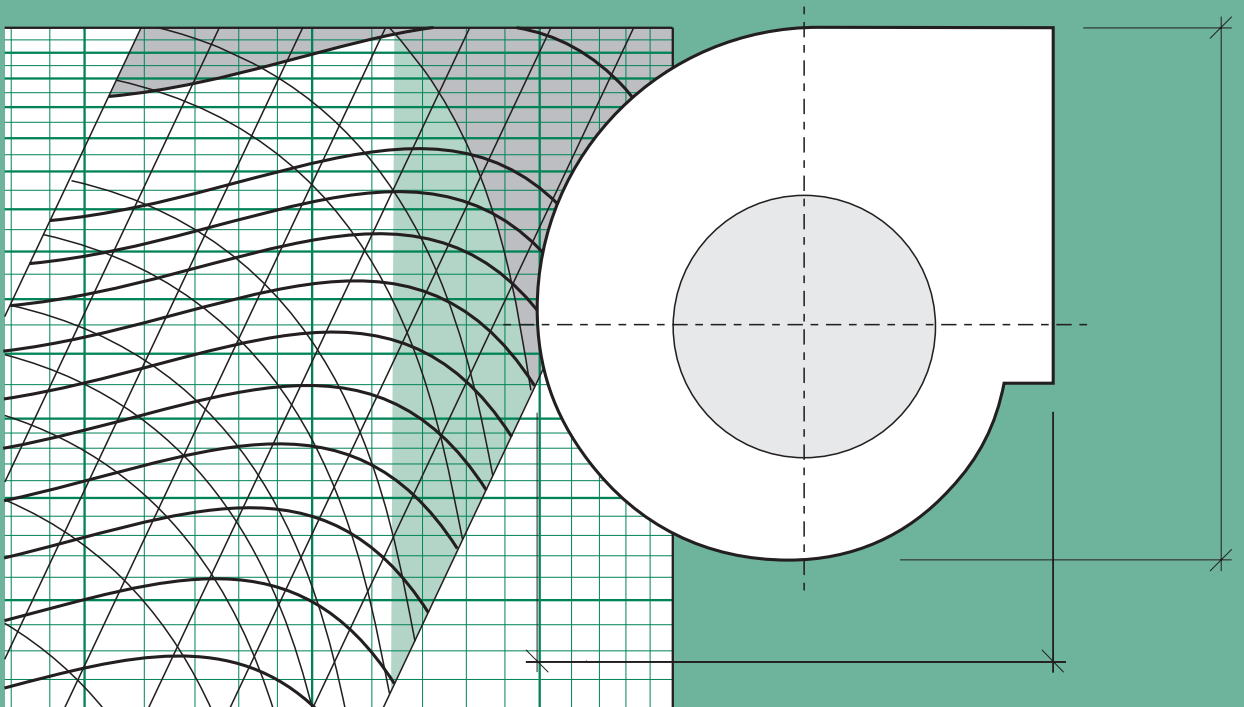

Dimensiones y curvas características

Dimensions and characteristics curves

Dimensions et courbes caractéristiques

Gama de Fabricación

Los ventiladores de la serie ligera la componen tres familias, a saber.

Simple turbina (L): Son ventiladores para accionamiento por transmisión y fijación mediante pies de apoyo. Se fabrican en once tamaños, del 7/7 al 18/18.

Doble turbina (T2L): Se trata de dos ventiladores de doble aspiración formando un solo conjunto y con eje de accionamiento común. Se fabrican en once tamaños, del 7/7 al 18/18.

Motor directamente acoplado (TMD): Son ventiladores de doble aspiración, con el motor directamente acoplado al rodete. Se fabrican en nueve tamaños, del 5/8 al 15/15. (Ver descripción en página 72).

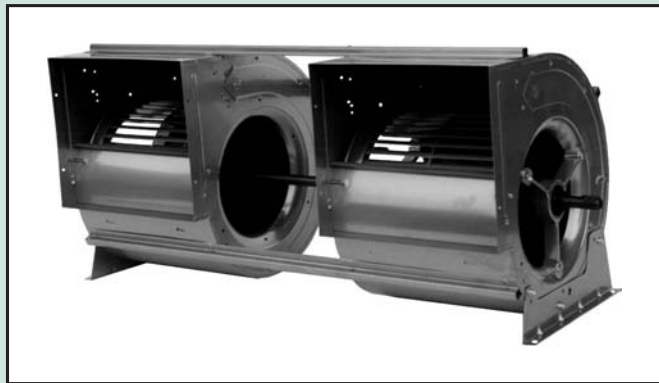

Características constructivas

Carcasa

Está integrada por: envolvente, laterales, deflector y soportes de rodamientos. Todos los elementos se fabrican en chapa galvanizada (senzimir) según UNE 36-130-86-Z-275. Excepto los soportes de rodamientos que se fabrican en aluminio.

-Envolvente: Para aumentar la rigidez y evitar posibles deformaciones de la boca de impulsión, va prevista de nervios embutidos.

En los ventiladores tipo T2L, las envolventes van unidas mediante tres perfiles en omega, de chapa galvanizada, remachados a las mismas, que confieren gran robustez al conjunto.

-Laterales: Los laterales se unen a la envolvente mediante soldadura eléctrica por puntos y están fabricados en una sola pieza. Los oídos de aspiración, diseñados de forma aerodinámica para conseguir mayor rendimiento, quedan embutidos en los mismos. Llevan una serie de taladros para fijación del soporte motor y de los pies de apoyo, permitiendo cuatro posiciones de montaje.

-Deflector: Va montado en la boca de impulsión y tiene por objeto evitar posibles turbulencias a la salida del aire, para lo cual su perfil tiene un diseño especial aerodinámico. La forma de unión del deflector a la envolvente, mediante un sistema de troquelados y tornillos, permite su desmontaje para una fácil extracción del rodete.

-Soportes de rodamientos: Van fijados a los oídos de aspiración mediante remaches, son de aluminio y están diseñados en forma de Y con un perfil estilizado de forma a obtener una gran rigidez y una mínima resistencia al paso del aire.

Rodete

Es de tipo a acción (alabes curvados hacia adelante), e integrado por: álabes, platos centrales, coronas laterales y moyú de fijación al eje. El ensamblaje es mediante sistema de alabe inserto a través de los platos y coronas. El conjunto va perfectamente equilibrado estática y dinámicamente, con máquinas electrónicas de alta sensibilidad según normas VDI-2060 y Q=6,3.

-Alabes: La forma de los álabes y el número de éstos están diseñados para conseguir el máximo rendimiento con un mínimo nivel sonoro. Se fabrican en chapa galvanizada (senzimir).

-Platos centrales: Los álabes se introducen en los platos mediante un troquelado y posterior entallado. Ambos platos, convexos están unidos entre sí y con el moyú mediante remaches de acero macizo, y son fabricados en chapa galvanizada (senzimir).

-Moyús de fijación: De acero estampado en caliente, se acopla a los platos mediante remaches y llevan un taladro ranurado para fijar el eje mediante chaveta y prisionero.

-Coronas laterales: Se fijan a los alabes mediante unos troquelados por donde se introducen estos y se remachan posteriormente. Se fabrican en chapa de acero galvanizada (senzimir).

Eje

Esta elaborado a partir de acero de alta resistencia y rectificado con estricta tolerancia (H-8), Los extremos van provistos de chavetas para la fijación de las poleas.

Rodamientos

Son de bolas de tipo rígido, pista exterior, autoalineables, herméticos y permanentemente engrasados.

Van montados sobre amortiguadores de caucho natural, asegurando una máxima silenciosidad.

Los ventiladores de la familia T2L llevan tres cojinetes, dos en los oídos de aspiración extremos y uno en uno de los dos oídos de aspiración centrales.

La temperatura de trabajo está situada entre -20° C y 80° C.

Pies de apoyo

Construidos a partir de chapa galvanizada y estampada. se suministran con sus correspondientes tornillos para el montaje. Los modelos T2L van provistos de un solo par de pies de apoyo, pudiendo suministrarse, bajo petición, un par suplementario.

Soporte motor

Construido en chapa de acero galvanizada, permite el montaje directo del motor en la envolvente.

El suministro comprende igualmente el tensor, goma de apoyo y sus correspondientes tornillos.

Acabado

El acabado de la envolvente se realiza recubriendo los puntos de soldadura con pintura antioxidante.

El eje va recubierto de un barniz de protección.



Production range

The range is made up 3 series

Single impeller (L)

These are indirect driven fans, fixed via mounting feet. Available in 11 sizes from 7/7 up to 18/18.

Double impeller (2L)

These are double impeller fans forming a single assembly with a common shaft. Available in 11 sizes from 7/7 up to 18/18.

Direct drive (TMD)

These are double inlet fans with the motor coupled direct to the impeller. Available in 9 sizes from 5/8 up to 15/15 (See p.72).

Construction features

Housing

Made of = Casing, side plates, and deflector, manufactured in galvanized sheet steel. The bearing supports are made of die cast aluminium.

-Scroll

In T2L series, the scrolls are joined by 3 omega-shaped sections of galvanized sheet steel, riveted to them.

-Side plates

They have pressed-in inlet cones and are joined to the scroll through electric spot welding. They have also a serie of holes for fixing the motor bracket and mounting feet.

-Deflector

Fitted in the scrool outlet to avoid possible whirls, and manufactured with a special aerodynamic design.

-Bearing brackets

Riveted to the side plates, and designed to offer minimum resistance to the air flow.

Impeller

It is constructed with forward curved blades and perfectly balanced statically and dynamically following VDI 2060 and Q=6,3 standards, Made of galvanized sheet steel.

-Blades

Specially profiled to ensure high efficiency.

-Main plates

The blades go accross the plates and are riveted to the side crowns.

-Fixing hub

Made of drop forged steel, and riveted to the main plates. It has a slot for fixing the shaft through a key and set screw.

Shaft

Manufactured using gaged steel with H8 tolerance. Both ends are provided for pulley mounting using a key.

Bearing

They are the stiff, self aligning ball bearing type, sealed and lubricated for life, and mounted on rubber, ensuring maximum silence. Serie T2L with 3 bearings. Working temperature: -20°C up to +80°C.

Mounting feet

Made of galvanized sheet steel, supplied with screws for assembling.

Motor bracket

The motor mounting bracket enables the motor to be mounted directly on the scroll. The supply also includes screws, tensor device, and rubber protection.

Finish

The housing is finished by coating the spot welding with rust proof paint. The shaft is coated with varnish protection.

Gamme de fabrication

Les ventilateurs de la série légère se composent de trois familles:

Simple turbine (L): Ce sont des ventilateurs avec accouplement par transmission et fixation au moyen de supports de base. Ils se fabriquent en 11 modèles, du 7/7 au 18/18.

Double turbine (T2L): Ce sont deux ventilateurs de double ouïe formant un seul ensemble, avec un arbre commun. Ils se fabriquent en 11 modèles, du 7/7 au 18/18.

Moteur incorporé (TMD): Ce sont des ventilateurs de double ovie, avec le moteur directement accouplé à la turbine. Se fabriquent en 9 modèles, du 5/8 au 15/15. (voir page 72).

Caractéristiques de fabrication

Carcasse

Composée de: volute, latéraux, déflecteur, et supports des roulements à billes, Elements fabriqués en tôle d'acier galvanisée.

-Volute: Possède des nervures de renforcement.

Dans la série T2L, les volutes sont unies avec trois profilés en oméga, de tôle galvanisée, rivés à celles-ci de façon à donner une grande robustesse à l'ensemble.

-Latéraux: Sont unis à la volute par soudure électrique par points et fabriqués d'une seule pièce. Les ouïes d'aspiration, de profil aérodynamique, son emboutis directement dans les latéraux. Ceux-ci possèdent une série de trous prévus pour la fixation du support-moteur et des deux supports de base.

-Déflecteur: A pour objet d'éviter des turbulences à la sortie du flux d'air. L'union du déflecteur à la volute, au moyen d'un système d'encoches et de vis, permet son démontage pour une facile extraction de la turbine.

-Supports des roulements à billes: Fixés aux ouïes d'aspiration avec des rivets et étudiés de façon à obtenir une grande rigidité et une résistance minima au passage du flux d'air. Fabriqués en Aluminium.

Turbine

Composée de: aubes, disques centraux, moyeu de fixation, et couronnes latérales. L'ensemble va parfaitement équilibré statiquement et dynamiquement selon norme VDI 2060 et Q=6,3.

-Aubes: La forme des aubes et leur quantité ont été étudiées pour assurer un rendement élevé. Fabriquées en tôle galvanisée.

-Disques centraux: Les aubes traversent les disques centraux au moyen d'un système d'entaillage. Les deux disques, convexes, sont unis entre-eux, et sont fabriqués en tôle galvanisée.

-Moyeu de fixation: Fabriqué en acier forgé à chaud, il est fixé aux disques par des rivets et possède un orifice ranuré pour fixer l'arbre avec une clavette et vis de serrage.

-Couronnes latérales: Fabriquées à partir de tôle d'acier galvanisée, elles permettent l'ancrage des aubes.

Arbre

Réalisé en acier rectifié, avec la tolérance H8. Les extrémités sont prévues pour la fixation de la poulie avec une clavette.

Roulements à billes

Du type rigide, à billes, autoalignés, hermétiques, lubrifiés à vie. Sont montés avec un amortisseur en caoutchouc.

Les ventilateurs T2L possèdent trois roulements.

La température de travail est située entre -20° C et 80° C.

Supports de base

Construits en tôle d'acier galvanisée, ils son fournis avec les vis correspondantes pour le montage.

Support moteur

Construi en tôle d'acier galvanisée, il permet le montage direct du moteur sur la volute.

Il est fourni également un tendeur, un plot d'appui en caoutchouc, et les vis correspondantes.

Finition

Toutes les soudures sont recouvertes d'une couche de peinture antirouille et l'arbre d'une couche de vernis spécial.

Gama de Fabricación

Esta serie está compuesta por cinco familias, a saber:

Simple rodete (R): Son ventiladores para accionamiento por transmisión y fijación por medio del bastidor tipo cubo que lleva incorporado. Se fabrica en diecinueve tamaños, del 7/7 al 30/28.

Simple rodete (SR): Son ventiladores para accionamiento por transmisión y fijación por medio del bastidor tipo cubo pero exento de travesaños para la unión de los bastidores hasta el 18/18 y de tipo triangular del 20/15 al 30/28.

Doble rodete (T2SR): Se trata de dos ventiladores de doble aspiración, reforzados con bastidores formando un sólo conjunto, con eje de accionamiento común. Se fabrica en once tamaños, del 7/7 al 18/18.

Doble rodete (T2R): Se trata de dos ventiladores de doble aspiración, reforzados con bastidores formando un sólo conjunto, con eje de accionamiento común. Esta familia difiere de la anterior en que el eje es de mayor diámetro y los rodamientos llevan soportes de fundición. Se fabrica en dieciocho tamaños, del 9/7 al 30/28.

Triple turbina (T3R): Se trata de tres ventiladores de doble aspiración, reforzados con bastidores formando un solo conjunto, con eje de accionamiento común. Se fabrica en dieciocho tamaños, del 9/7 al 30/28.

Características constructivas



Carcasa

A efectos de descripción, vamos a dividir la gama de modelos en dos series: del tamaño 7/7 al 18/18, que llamaremos serie pequeña, y los de tamaños superiores, que llamaremos serie grande.

-La carcasa de la serie pequeña está integrada por: Envoltente, laterales, deflectores, soporte de rodamientos y bastidores. Todos estos elementos se fabrican en chapa galvanizada (senzimir), excepto en las familias SR, R, y T2SR que el soporte de rodamiento es de aluminio en forma de Y.

-La carcasa de la serie grande está integrada por: Envoltente, laterales, deflectores. Estos elementos se fabrican en chapa galvanizada (senzimir). El bastidor está elaborado con perfiles de chapa blanca conformados en frío, con soportes de rodamientos de pletina de acero de gran resistencia, todo el conjunto de bastidor va recubierto con pintura en polvo epoxi secado al horno dándole una gran dureza en la superficie.

-Envoltente: La rigidez de la boca de impulsión se consigue mediante el bastidor.

-Laterales: Los laterales de toda la gama se fabrican en una sola pieza, quedando embutidos en los mismos los oídos de aspiración.

-Deflector: Tanto en la serie grande como en la serie pequeña, tiene un fácil desmontaje y permite la extracción del rodete.

-Bastidor: Su forma cúbica confiere una gran rigidez al ventilador y permite el montaje en cuatro posiciones distintas excepto la serie grande de la familia (SR) que no puede montarse nada mas que en dos orientaciones.

-Soportes de rodamientos: En la serie pequeña, van fijados a los oídos de aspiración mediante remaches, y tienen idéntica forma

que los de la serie ligera. En la serie grande, así como en las series T2R y T3R, los soportes de rodamientos apoyan en un bastidor de perfil en U, soldado al bastidor principal.

Rodete

Es de tipo a acción (álabes curvados hacia delante), e integrado por: álabes, platos centrales, coronas laterales y moyús de fijación al eje. El conjunto va perfectamente equilibrado estática y dinámicamente, con máquinas electrónicas de alta sensibilidad según normas VDI-2060 y Q=6,3.

-Álabes: La forma de los álabes y su número han sido determinados de forma a asegurar un alto rendimiento. Están fabricados en chapa galvanizada (senzimir).

-Platos centrales: En la serie pequeña, los alabes se introducen en los platos mediante un troquelado y posterior entallado. Ambos platos, convexos, están unidos entre si y con el moyú mediante remaches de acero macizo y son fabricados en chapa galvanizada. La serie grande esta fabricada a partir de dos turbinas de simple aspiración unidas entre si con tornillos y un moyú de aluminio de grandes dimensiones.

El sistema de ensamblaje de los alabes es similar al de la serie pequeña (alabes insertos).

-Moyús de fijación: De acero estampado en caliente y cincado posterior por tratamiento electrolítico van mecanizados bajo unos estrictos controles, mediante máquina de alta precisión; van provistos de un taladro ranurado para fijación del eje y se acoplan a los platos centrales mediante remaches.

En la serie grande el moyú es de fundición de aluminio y va fijado con tornillos.

-Coronas laterales: Se fijan a los alabes mediante unos troquelados interiores y un posterior remachado.

Eje

Esta elaborado a partir de acero de alta resistencia y rectificado con estricta tolerancia (H-8), Los extremos van provistos de chavetas para la fijación de las poleas.

Rodamientos

Son del tipo rígido, a bolas autoalineables, herméticos, permanentemente engrasados.

En la serie pequeña (únicamente para las familias SR, R, T2SR), los rodamientos van montados sobre amortiguadores de caucho natural. En el resto de modelos R, T2R y T3R, los rodamientos van montados sobre soporte de fundición. Este tipo de soporte lleva incorporado un engrasador.

La serie T3R lleva montados 3 rodamientos salvo el modelo 9/7 - T3R que lleva 2.

Asimismo, en los ventiladores provistos de rodamientos sobre soportes de fundición, el límite superior de la temperatura de trabajo queda ampliado a 110° C.

Acabado

El acabado de la envoltente se realiza recubriendo los puntos de soldadura con pintura antioxidante.

El eje va recubierto de un barniz de protección.

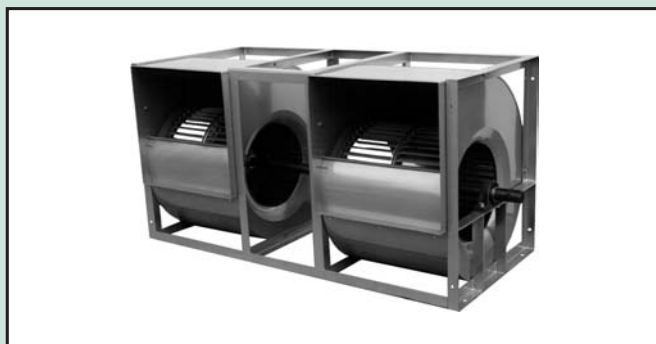

Production range

The range is made up 5 series:

Single impeller (R)

These are indirect driven fans, fixed via the built in frame.

Available in 14 sizes, from 7/7 up to 30/28.

Single impeller (SR)

Similar to the R series, but without cross-members up to size 18/18 and a triangular-side frame from 20/15 up to 30/28.

Double impeller (T2SR)

These are double impeller semi-reinforced, forming a single assembly with a common shaft, mounted on three bearings and antivibration mounts. Available in 11 sizes from 7/7 up to 18/18.

Double impeller (T2R)

Similar to the T2SR series, but with a larger diameter shaft and two bearings mounted on cast iron bracket. Available in 18 sizes from 9/7 up to 30/28.

Triple impeller (T3R)

These are three double inlet reinforced fans, forming a single assembly similar to the T2R series. Available in 18 sizes from 9/7 up to 30/28.

Construction features.**Housing**

Made up of: casing, side-plates and deflector, manufactured in galvanized sheet steel; all side-plates have pressed in inlet cones. The bearing supports are made of die cast aluminium up to size 18/18 and R,SR,T2SR series. All other sizes and series have cast iron brackets mounted on to the steel side frame. The angular frames are made of galvanized sheet steel up to size 18/18 and in painted sheet steel from size 20/15.

Impeller

The impeller is balanced following VDI 2060 standards both statically and dynamically. Up to size 18/18, the construction is the same as described for the light series. From size 20/15 up to 30/28, the impellers are made up of two semi-impellers fixed back by back with screws, having also riveted blades.

Shaft

Manufactured using gaged-steel with H8 tolerance. Both ends are provided for pulley mounting using a key.

Bearings

They are the stiff, self-aligning ball-bearing type, sealed and lubricated for life. For fans with cast iron brackets, the working temperature can reach 110° C.

Finish

The housing is finished by coating the spot welding with rustproof paint. The shaft is coated with a varnish protection.

Gamme de fabrication

Les ventilateurs de la série renforcée se composent de 5 familles, à savoir:

Simple turbine (R)

Ventilateurs avec accouplement par transmission et fixation au moyen du châssis. Se fabriquent en 19 modèles du 7/7 au 30/28

Simple turbine (SR)

Similaire à la série R mais sans traverse, jusqu'au modèle 18/18, et avec un châssis triangulaire du 20/15 au 30/28.

Double turbine (T2 SR)

Ce sont deux ventilateurs double ouïe, renforcés, formant un seul ensemble, avec un arbre commun, et 3 roulements montés sur caoutchouc. Se fabriquent en 11 modèles du 7/7 au 18/18.

Double turbine (T2R)

Construction similaire à la précédente, mais avec un diamètre d'arbre supérieur, et 2 roulements montés avec support en fonte. Se fabriquent en 18 modèles du 9/7 au 30/28

Triple turbine (T3R)

Ce sont trois ventilateurs, double ouïe, renforcés, formant un seul ensemble, de construction similaire à la série T2R. Se fabriquent en 18 modèles du 9/7 au 30/28

Caractéristiques de fabrication.**Carcasse**

a) Du 7/7 au 18/18

Composée de: volute, latéraux, deflecteur, supports de roulements à billes, et châssis. Elements fabriqués en tôle d'acier galvanisée, sauf le support de roulements qui est en aluminium.

b) Du 20/15 au 30/28

Composée de: Volute, Latéraux, Défecteur.

Fabriqués en tôle d'acier galvanisée, et un châssis fabriqué en cornière, comprenant les supports de roulements.

L'ensemble du châssis est recouvert de peinture epoxy.

Dans tous les cas le pavillon d'aspiration est embouti dans le latéral.

Chassis

Sa forme cubique confère une grande rigidité au ventilateur et permet de le monter en 4 positions différentes, sauf dans la série SR du 20/15 au 30/28, où il n'y a que 2 positions possibles.

Turbine

Composée de: aubes, disques centraux, moyeux de fixation, et couronnes latérales. L'ensemble va équilibré statiquement et dynamiquement. Selon norme VDI 2060. Fabriquée en tôle galvanisée.

À partir du 20/15, la turbine est formée de deux turbines de simple aspiration unies par visserie.

Moyeux de fixation

Voir série légère.

Jusqu'au modèle 18/18: 1 moyeu en acier.

À partir du modèle 20/15: 1 moyeu en aluminium.

Arbre

Réalisé en acier rectifié, H8. Les extrémités sont prévues pour la fixation de la poulie avec une clavette.

Roulement à billes

Jusqu'au modèle 18/18 dans les séries SR, R et T2SR, les roulements sont montés avec un amortisseur en caoutchouc naturel. Dans les modèles supérieurs série R, et dans tous les modèles série T2R, T3R, les roulements sont montés avec un support en fonte, muni de prise de graissage. Temperature limite, avec support en fonte; 110°C

Finition

Toutes les soudures sont recouvertes d'une couche de peinture anti-rouille, et l'arbre d'une couche de vernis spécial.

Serie

L

T2L

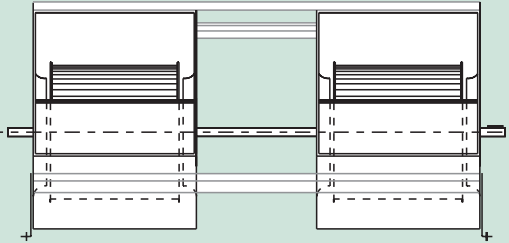
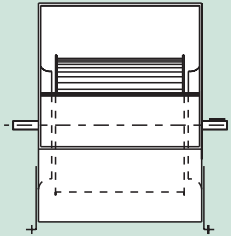
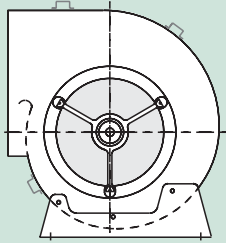

DEL 7/7 HASTA EL 18/18

Serie

SR

T2SR

R

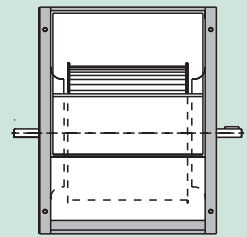
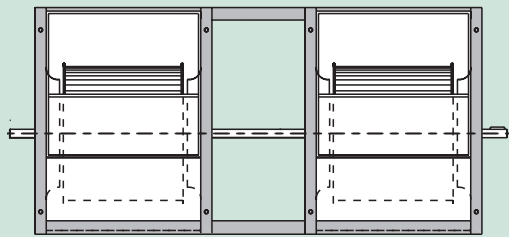
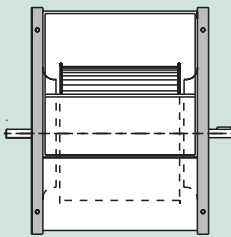
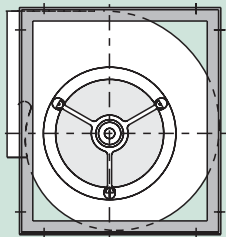

DEL 7/7 HASTA EL 18/18

Serie

R

T2R

DEL 20/15 HASTA EL 30/28

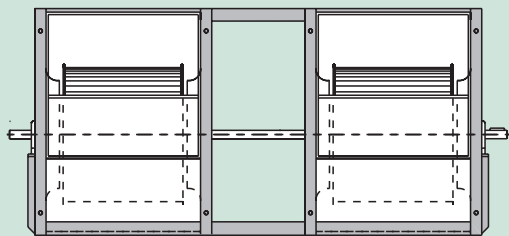
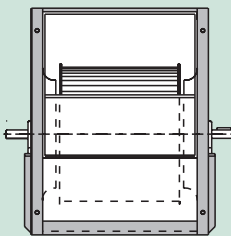
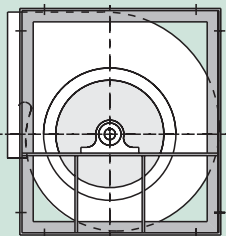

DEL 9/7 HASTA EL 30/28

Serie

SR

T3R

DEL 20/15 HASTA EL 30/28

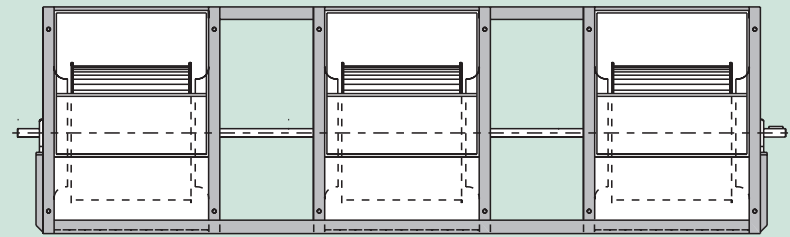
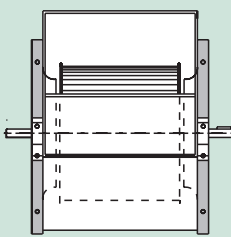
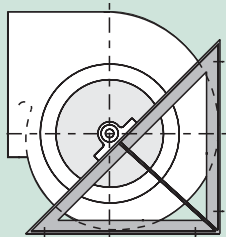

DEL 9/7 HASTA EL 30/28

DIMENSIONES SERIES L y T2L SEGUN ORIENTACIONES

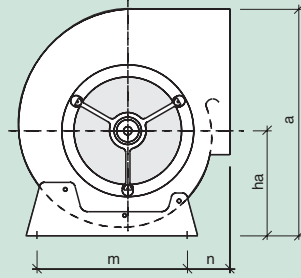

ORIENTACION 1 y 9

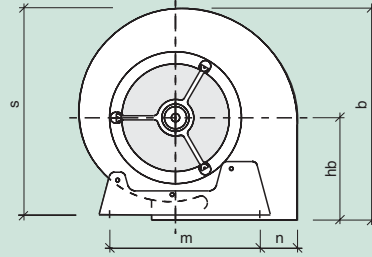

ORIENTACION 3 y 11

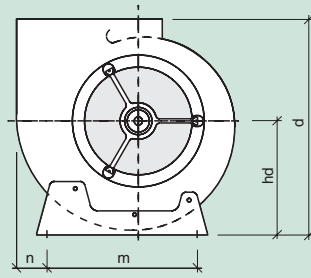

ORIENTACION 7 y 15

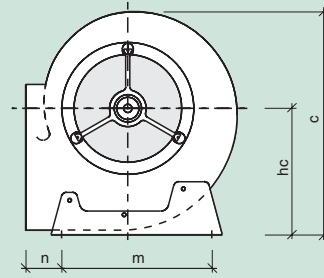

ORIENTACION 5 y 13

SERIE L y T2L

TAMAÑO	ORIENTACION 1 y 9				ORIENTACION 3 y 11					ORIENTACION 5 y 13				ORIENTACION 7 y 15			
	a	ha	m	n	b	hb	m	n	s	c	hc	m	n	d	hd	m	n
7/7	326	145	228	60	307	145	228	16	303	328	185	228	18	315	172	228	30
9/7	400	182	280	78	375	180	280	45	370	415	243	280	68	382	202	280	45
9/9	400	182	280	78	375	180	280	45	370	415	243	280	68	382	202	280	45
10/8	452	208	315	82	427	207	315	50	424	472	275	315	72	437	230	315	47
10/10	452	208	315	82	427	207	315	50	424	472	275	315	72	437	230	315	47
12/9	530	238	400	82	498	236	400	35	492	560	327	400	73	506	268	400	35
12/12	530	238	400	82	498	236	400	35	492	560	327	400	73	506	268	400	35
15/11	622	282	460	94	578	271	460	52	570	649	381	460	82	585	316	460	55
15/15	622	282	460	94	578	271	460	52	570	649	381	460	82	585	316	460	55
18/13	751	336	580	88	690	322	580	80	685	775	449	580	68	699	380	580	84
18/18	751	336	580	88	690	322	580	80	685	775	449	580	68	699	380	580	84

Serie L

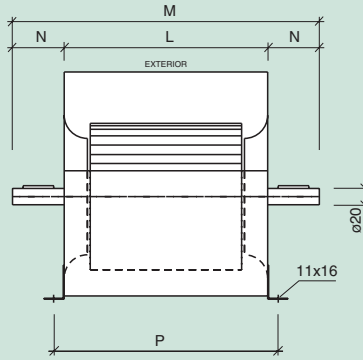
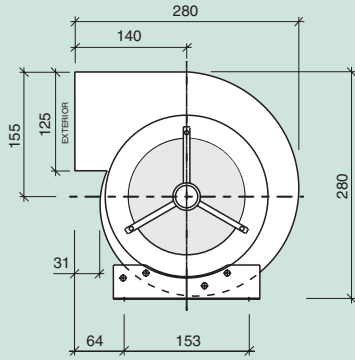

TAMAÑO	L	M	N	P	DENOMINACION METRICA
6/5	216	377	80.5	242	180 / 150
6/6	250	377	63.5	276	180 / 185
6/7	278	428	75	304	180 / 215

DIMENSIONES SEGUN ORIENTACION

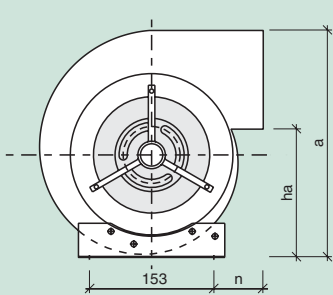

ORIENTACION 1 y 9

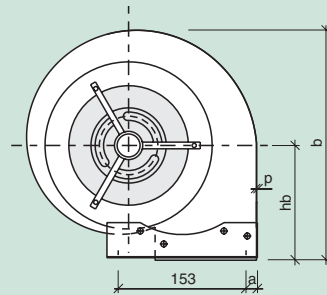

ORIENTACION 3 y 11. POS.1

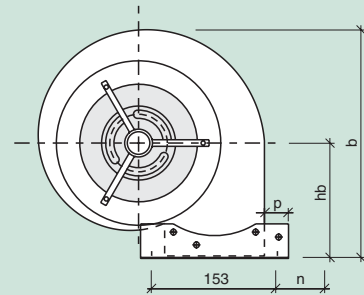

ORIENTACION 3 y 11. POS.2

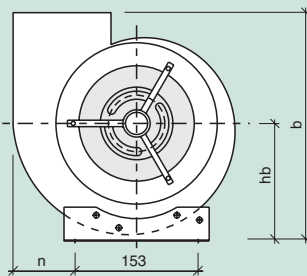

ORIENTACION 7 y 15

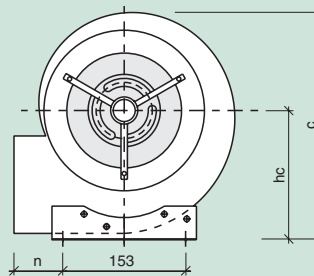

ORIENTACION 5 y 13

ORIENTACION 1 y 9			ORIENTACION 3 y 11. POS.1				ORIENTACION 3 y 11. POS.2				ORIENTACION 5 y 13			ORIENTACION 7 y 15		
a	ha	n	b	hb	a	p	b	hb	a	p	c	hc	n	d	hd	n
278	125	64	275	136	13.5	1	275	136	13.5	27	282	160	64	285	145	77

Serie - Series - Serie L		6/5						
Límite de empleo. <i>Operational limit.</i> Limite d'emploi.	n max. motor max.	rpm kW	2700 1					
Velocidad tangencial. <i>Tip speed.</i> Vitesse tangentielle.	u	m/s	$n (\text{min}^{-1}) \times 0.0090$					
Momento de inercia. <i>Moment of inertia.</i> Moment d'inertie.	$PD^2/4$	Kg m ²	0.0067					
Peso del ventilador. <i>Fan weight.</i> Poids du ventilateur.		Kg	4					

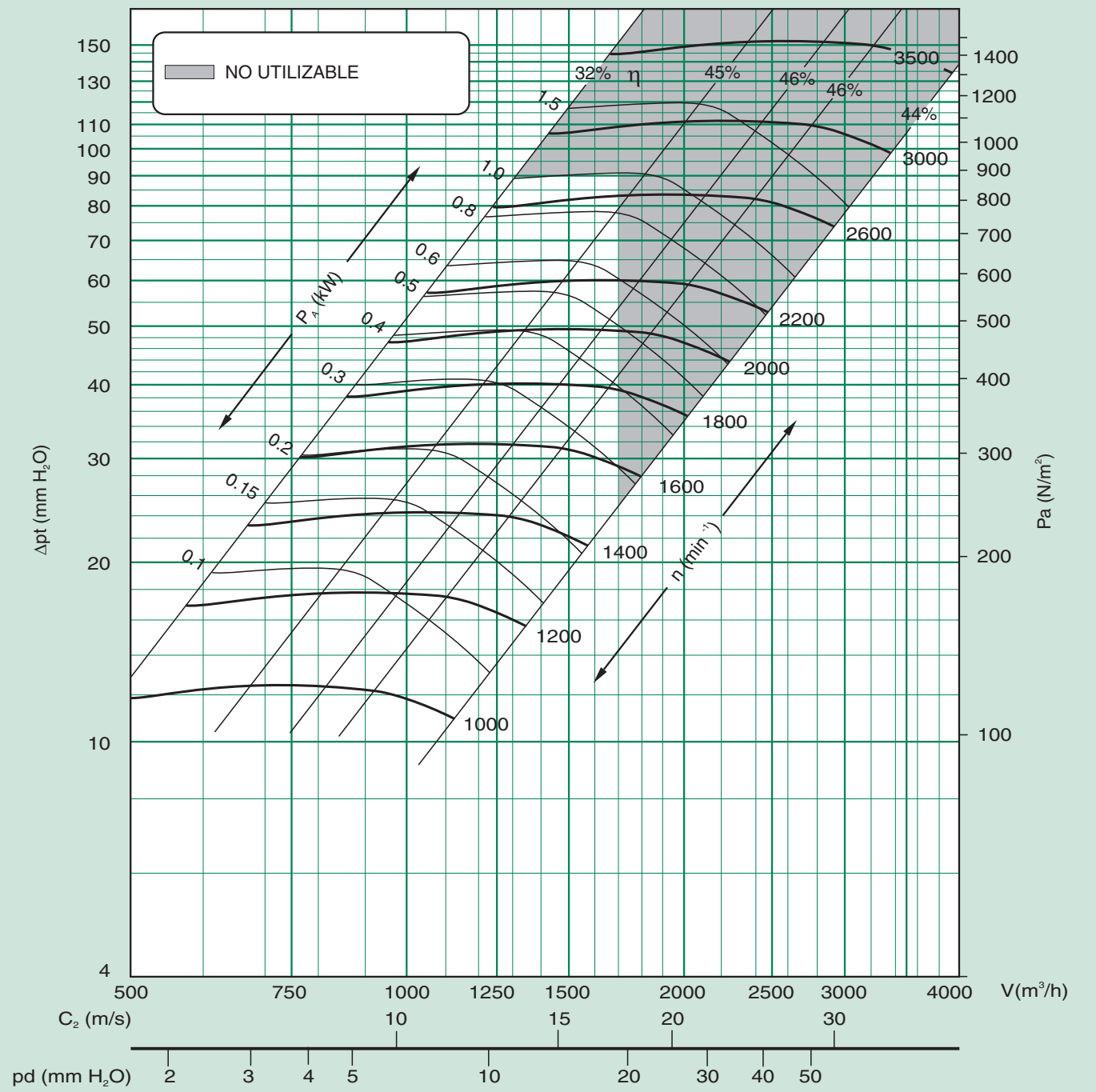

Serie - Series - Serie L		6/6							
Límite de empleo. Operational limit. Limite d'emploi.	n max. motor max.	rpm kW	2600 1						
Velocidad tangencial. Tip speed. Vitesse tangentielle.	u	m/s	$n (\text{min}^{-1}) \times 0.0090$						
Momento de inercia. Moment of inertia. Moment d'inertie.	$PD^2/4$	Kg m ²	0.0075						
Peso del ventilador. Fan weight. Poids du ventilateur.		Kg	4.5						

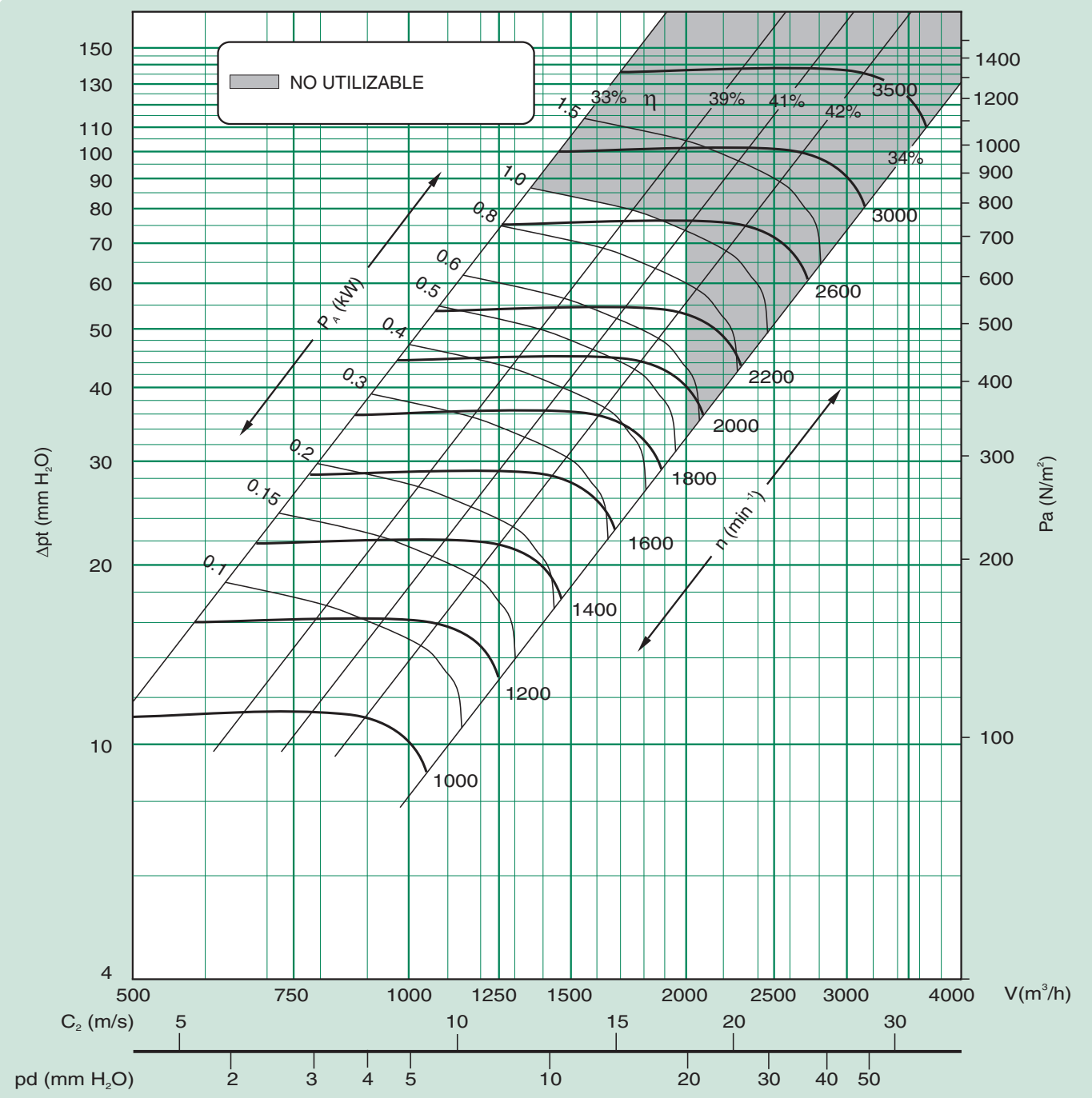

Serie - Series - Serie L		6/7						
Límite de empleo. <i>Operational limit.</i> Limite d'emploi.	n max. motor max.	rpm kW	2500 1					
Velocidad tangencial. <i>Tip speed.</i> Vitesse tangentielle.	u	m/s	n (min ⁻¹) x 0.0090					
Momento de inercia. <i>Moment of inertia.</i> Moment d'inertie.	PD ² /4	Kg m ²	0.0081					
Peso del ventilador. <i>Fan weight.</i> Poids du ventilateur.		Kg	5					

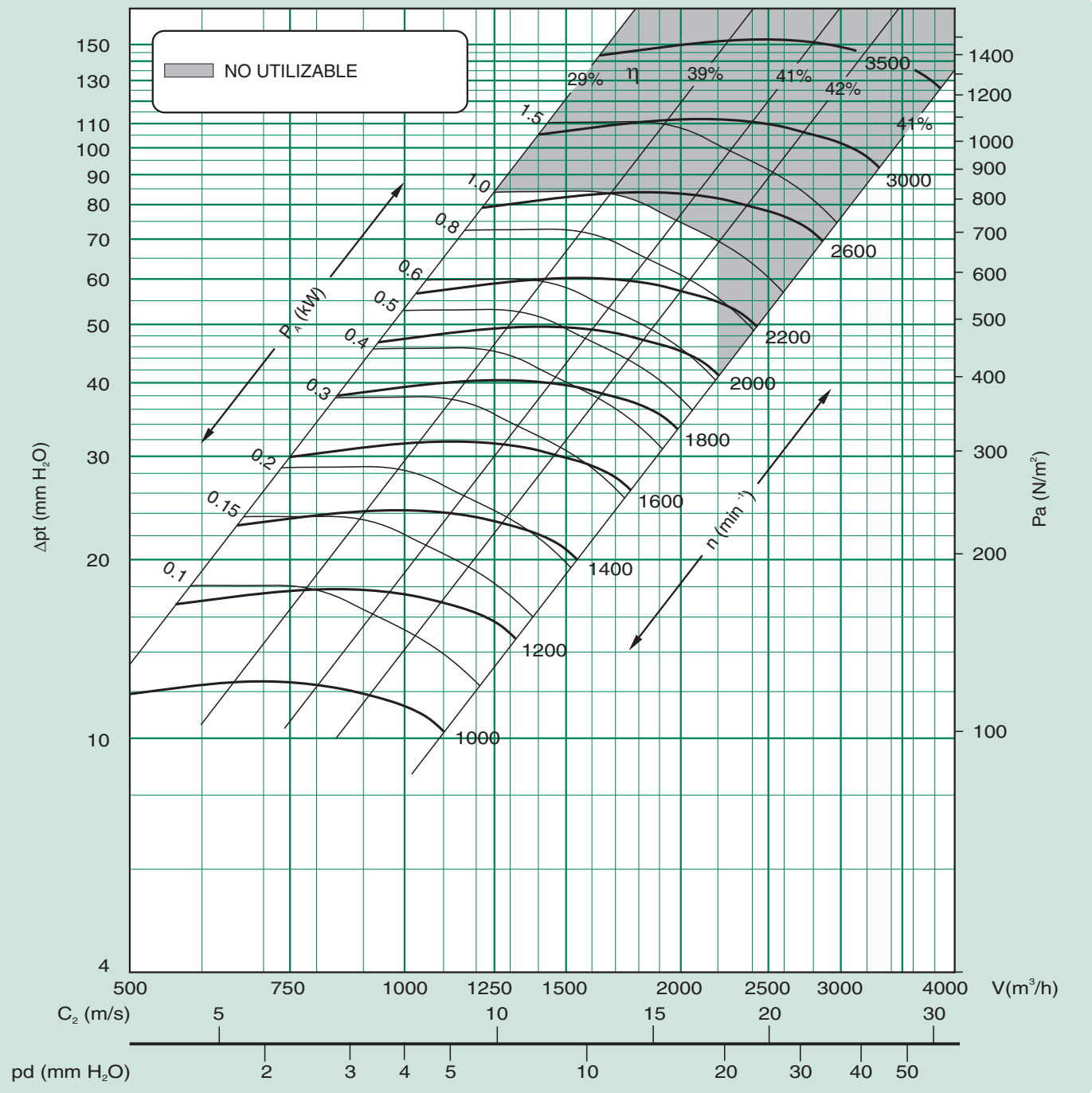

Serie

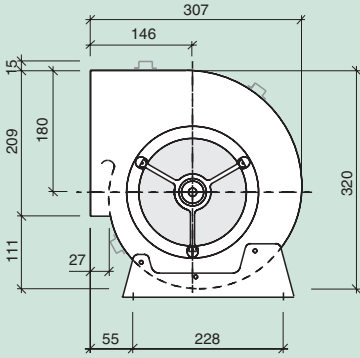

L

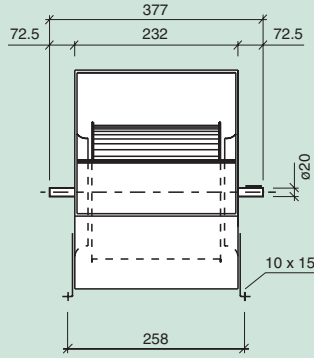

T2L

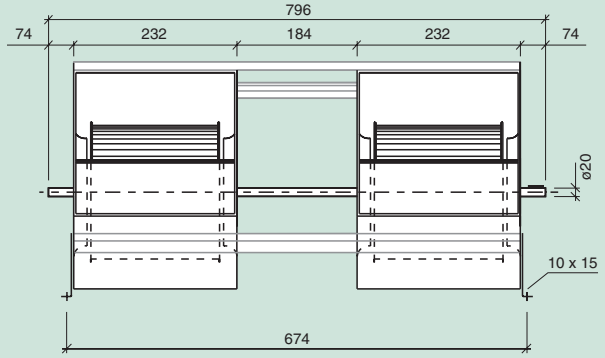

Serie

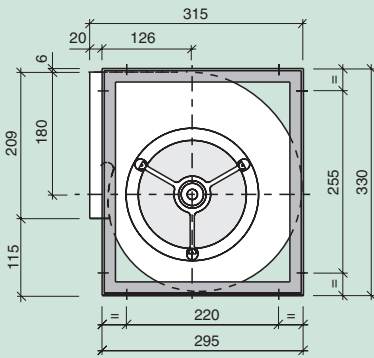

SR

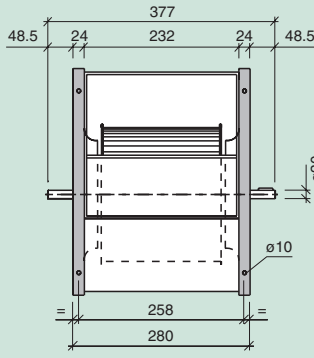

T2SR

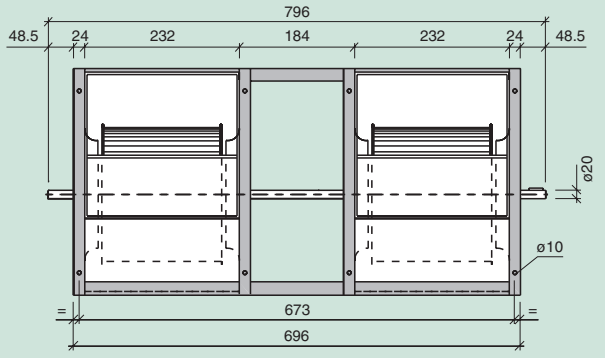

Serie

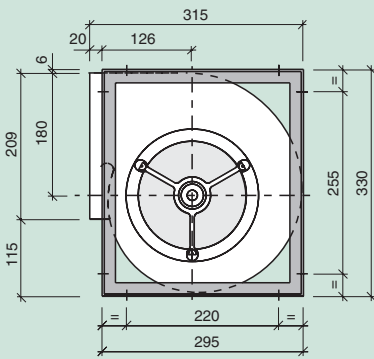

R

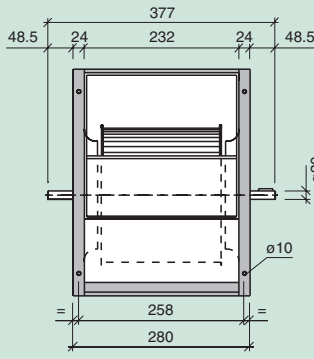

Serie - Series - Serie		L	SR	R	T2L	T2SR	T2R	T3R
Límite de empleo. Operational limit. Limite d'emploi.	n max. motor max.	rpm kW	2500 1	2700 1.2	3100 1.5	2400 1.5	2500 1.5	
Velocidad tangencial. Tip speed. Vitesse tangentielle.	u	m/s	n (min ⁻¹) x 0.0097					
Momento de inercia. Moment of inertia. Moment d'inertie.	PD ² /4	Kg m ²	0.02	0.02	0.02	0.04	0.04	
Peso del ventilador. Fan weight. Poids du ventilateur.		Kg	5	6	7	11.5	13	
Coefficientes de corrección. Correction factors. Coefficients de correction.	V P _A n	m ³ /h kW min ⁻¹	x 1 x 1 x 1	x 1 x 1 x 1	x 1 x 1 x 1	x 2 x 2.15 x 1.05	x 2 x 2.15 x 1.05	

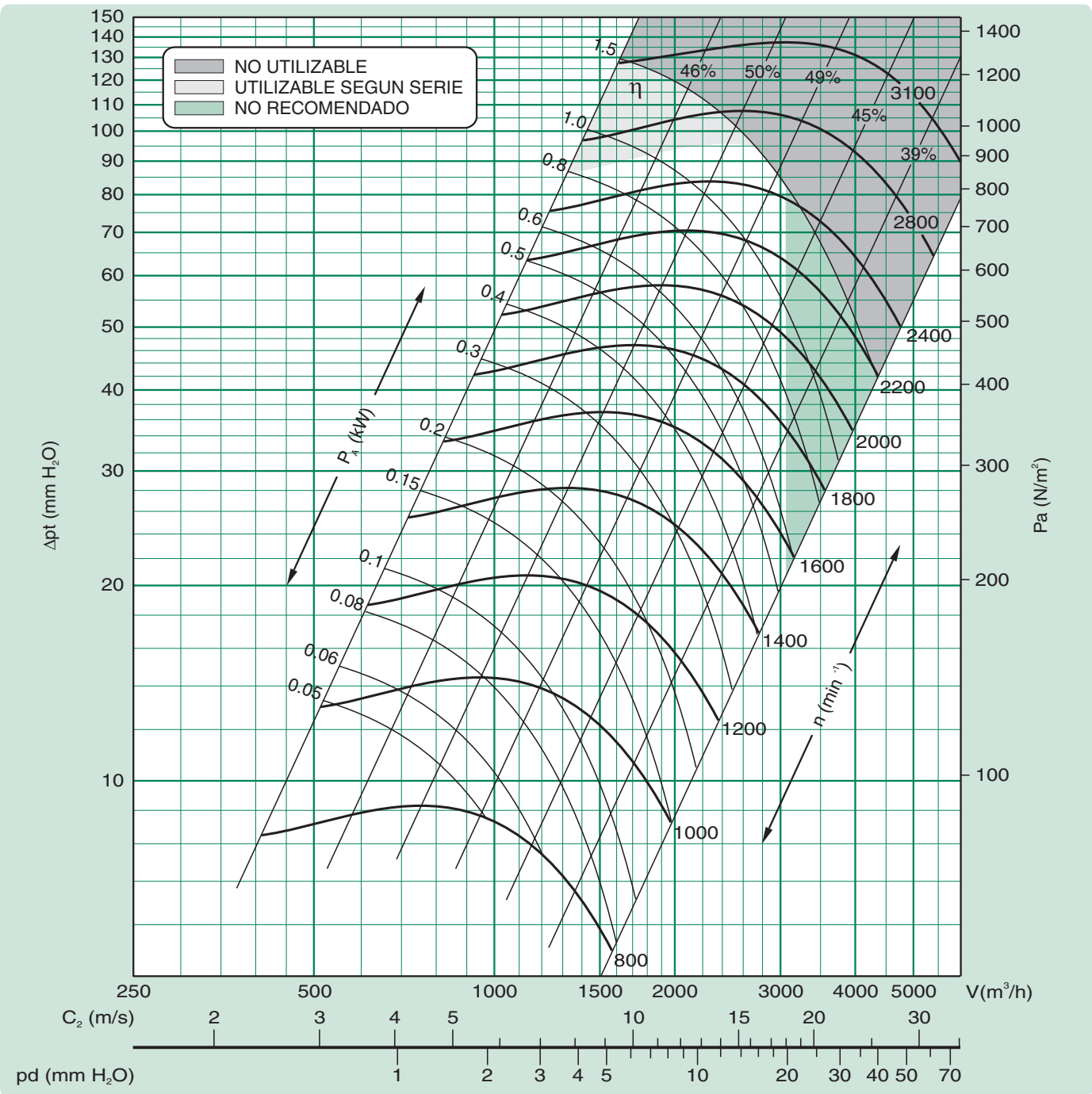

Serie

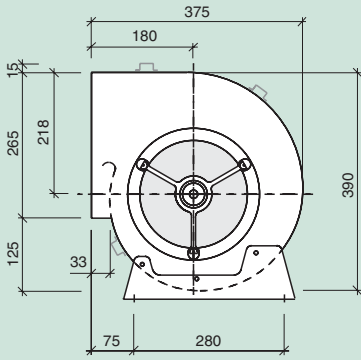

L

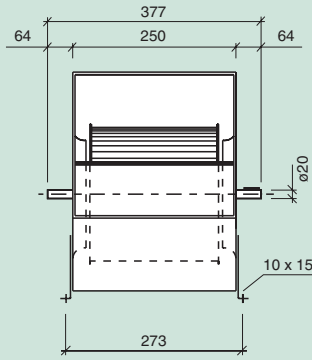

T2L

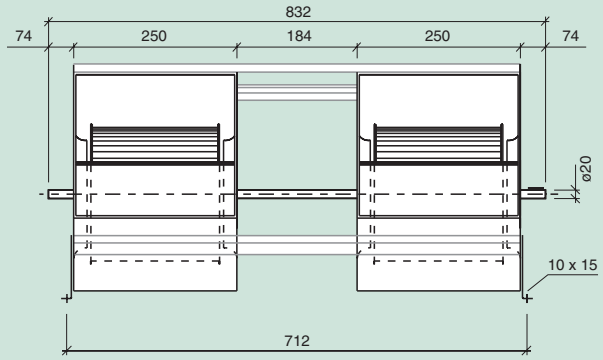

Serie

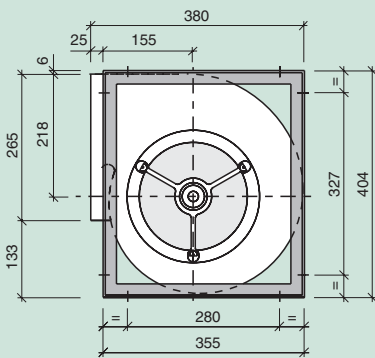

SR

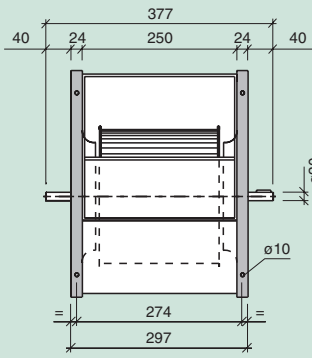

T2SR

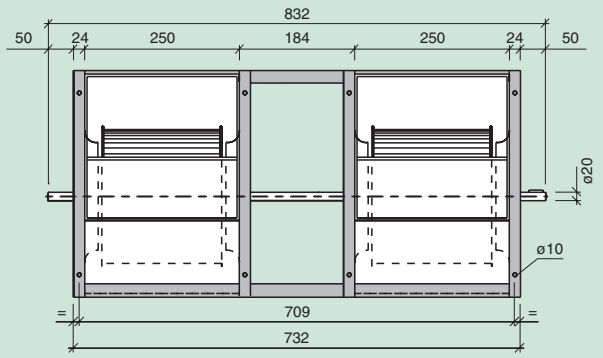

Serie

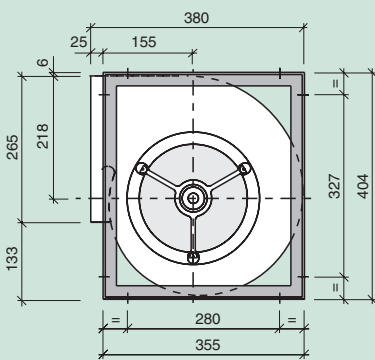

R

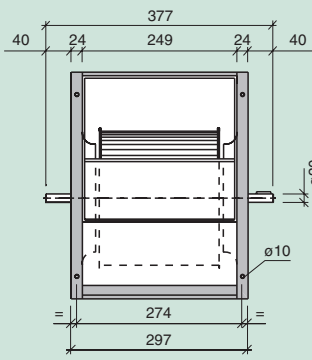

Serie

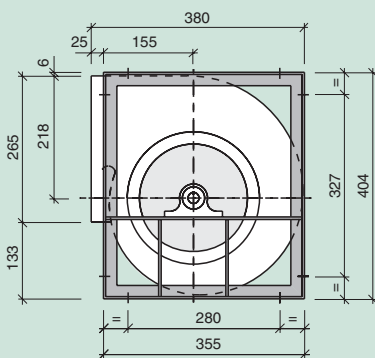

T2R

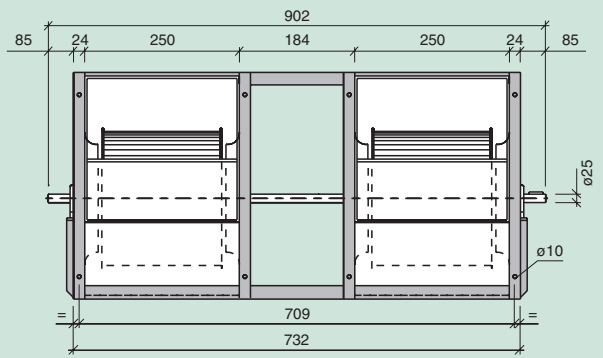

Serie - Series - Serie		L	SR	R	T2L	T2SR	T2R	T3R	
Límite de empleo. Operational limit. Limite d'emploi.	n max. motor max.	rpm kW	2000 1.5	2100 1.5	2400 2	1800 1.5	2100 2	2400 3	1800 4.5
Velocidad tangencial. Tip speed. Vitesse tangentielle.	u	m/s	n (min ⁻¹) x 0.0126						
Momento de inercia. Moment of inertia. Moment d'inertie.	PD ² /4	Kg m ²	0.03	0.03	0.03	0.06	0.06	0.06	0.09
Peso del ventilador. Fan weight. Poids du ventilateur.		Kg	8.5	10.5	11	19	20	25	40
Coefficientes de corrección. Correction factors. Coefficients de correction.	V P _A n	m ³ /h kW min ⁻¹	x 1 x 1 x 1	x 1 x 1 x 1	x 1 x 1 x 1	x 2 x 2.15 x 1.05	x 2 x 2.15 x 1.05	x 2 x 2.15 x 1.05	x 3 x 3.25 x 1.08

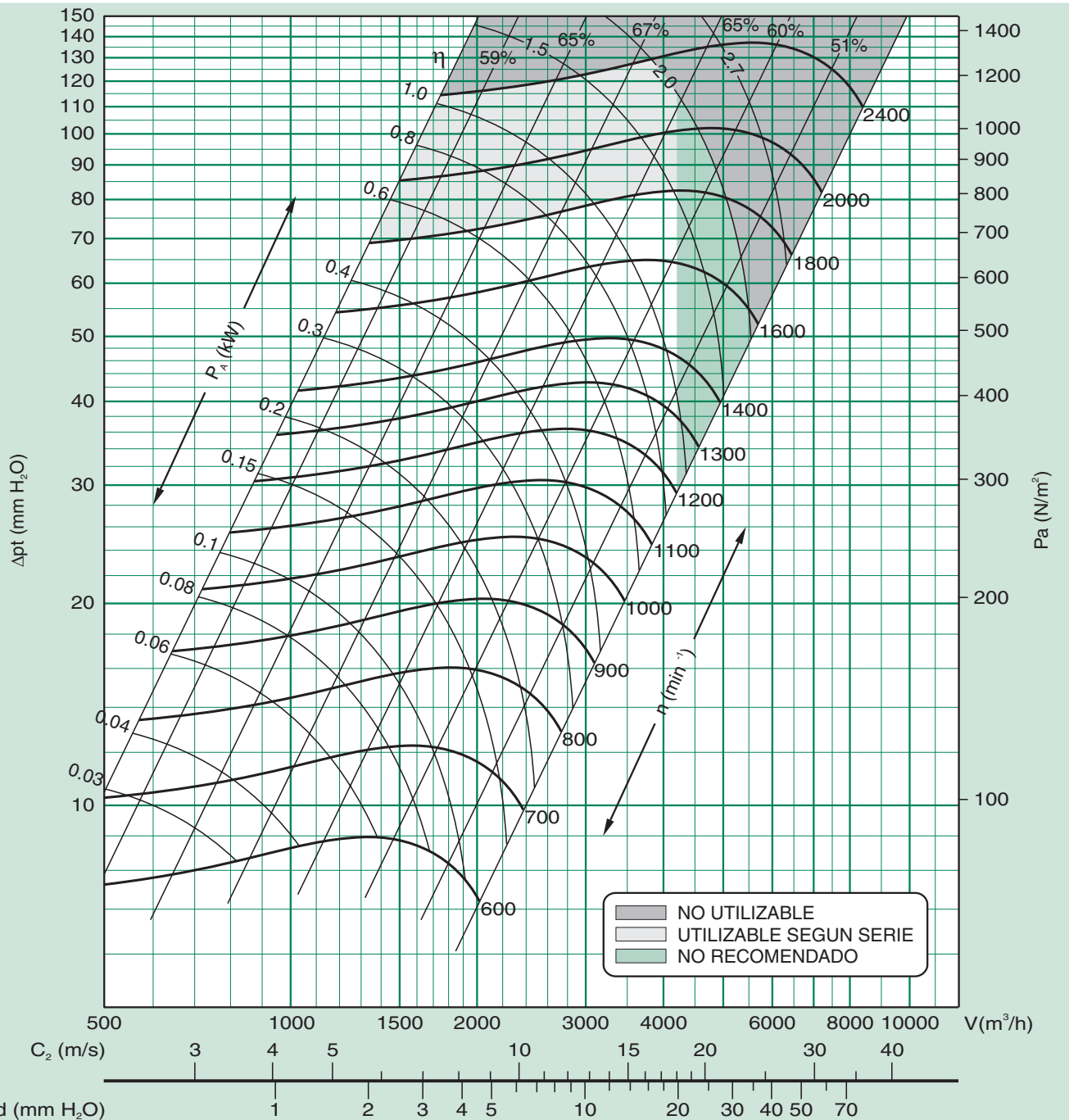

Serie

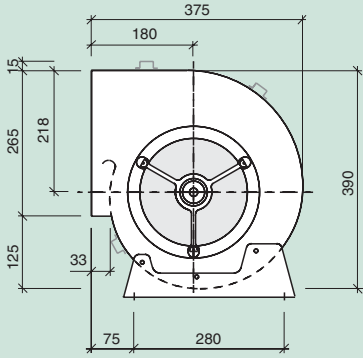

L

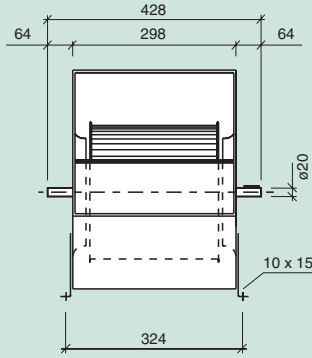

T2L

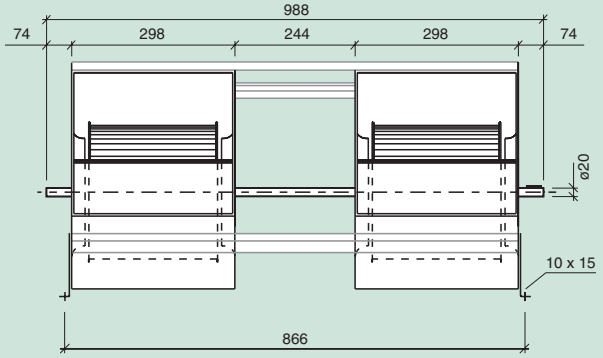

Serie

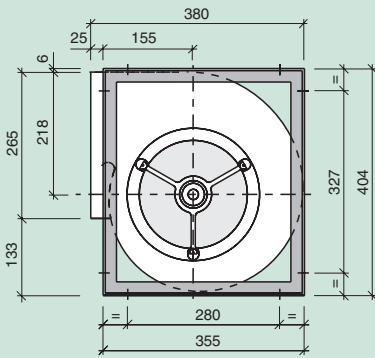

SR

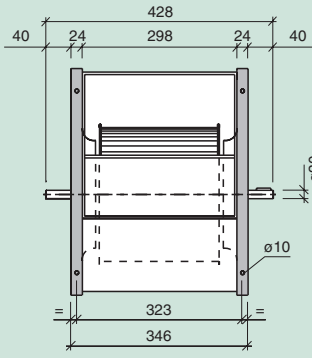

T2SR

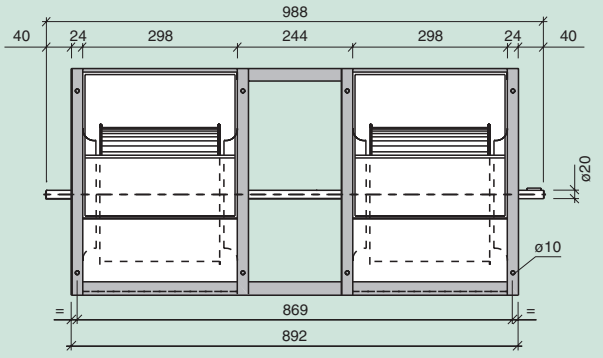

Serie

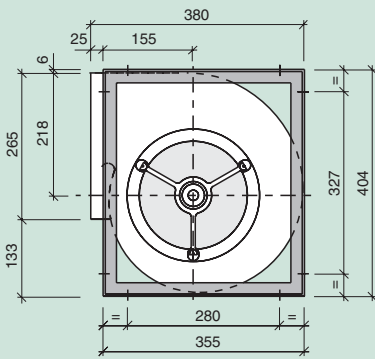

R

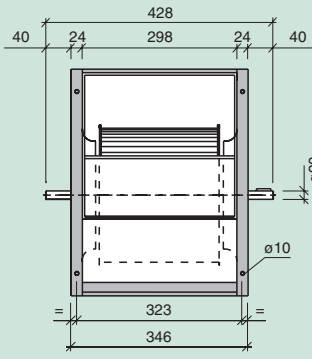

Serie

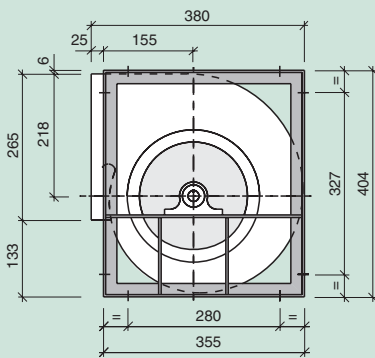

T2R

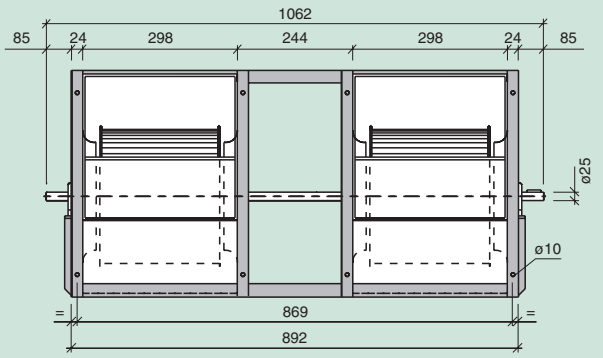

Serie - Series - Serie		L	SR	R	T2L	T2SR	T2R	T3R	
Límite de empleo. <i>Operational limit.</i> Limite d'emploi.	n max. motor max.	rpm kW	2000 1.5	2100 1.7	2400 2.3	1800 1.7	2100 2	2400 3	1800 4.5
Velocidad tangencial. <i>Tip speed.</i> Vitesse tangentielle.	u	m/s	n (min ⁻¹) x 0.0140						
Momento de inercia. <i>Moment of inertia.</i> Moment d'inertie.	PD ² /4	Kg m ²	0.06	0.06	0.06	0.11	0.11	0.11	0.16
Peso del ventilador. <i>Fan weight.</i> Poids du ventilateur.		Kg	9	11.5	12.5	20.5	22	30	58
Coefficientes de corrección. <i>Correction factors.</i> Coefficients de correction.	V P _A n	m ³ /h kW min ⁻¹	x 1 x 1 x 1	x 1 x 1 x 1	x 1 x 1 x 1	x 2 x 2.15 x 1.05	x 2 x 2.15 x 1.05	x 2 x 2.15 x 1.05	x 3 x 3.25 x 1.08

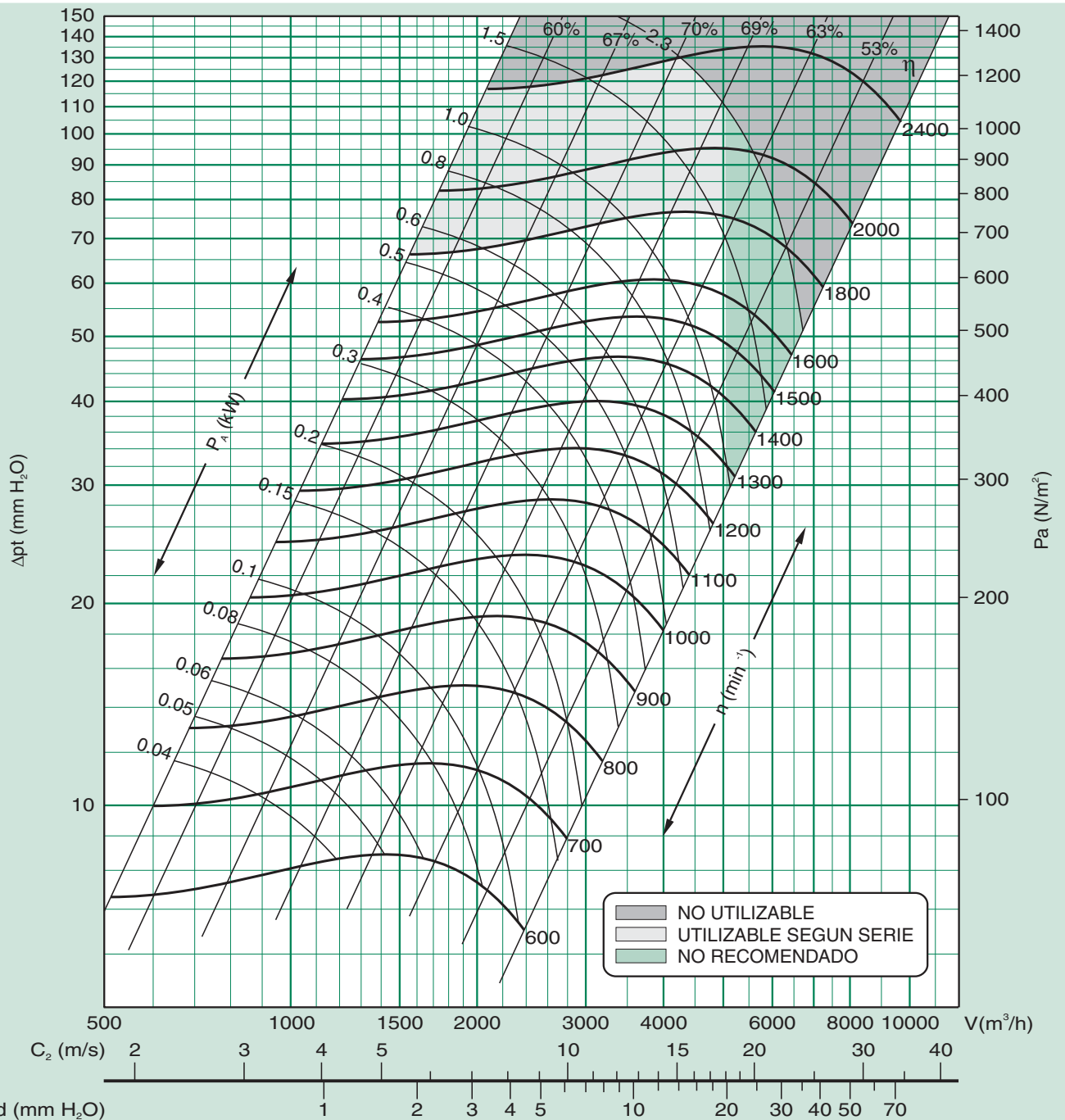

Serie

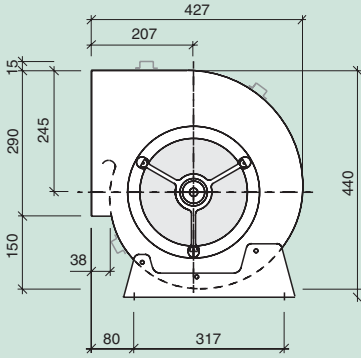

L

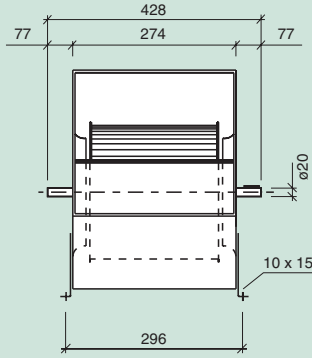

T2L

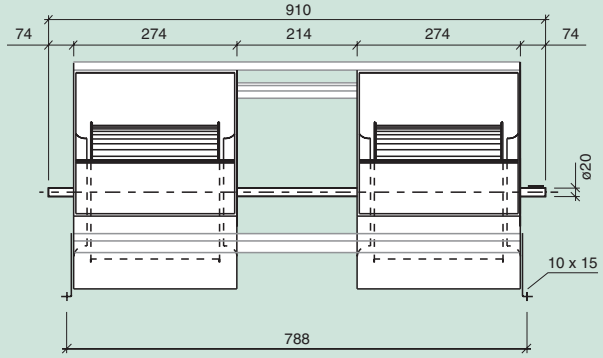

Serie

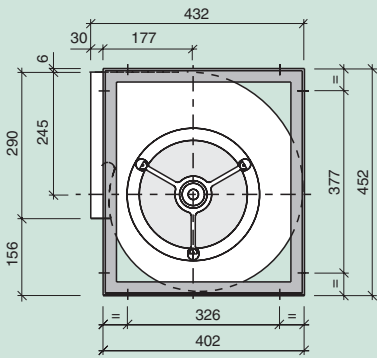

SR

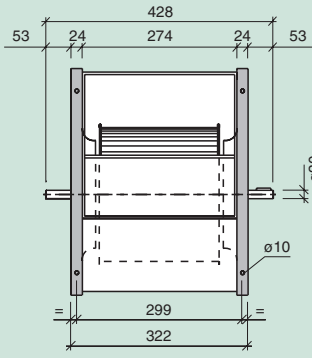

T2SR

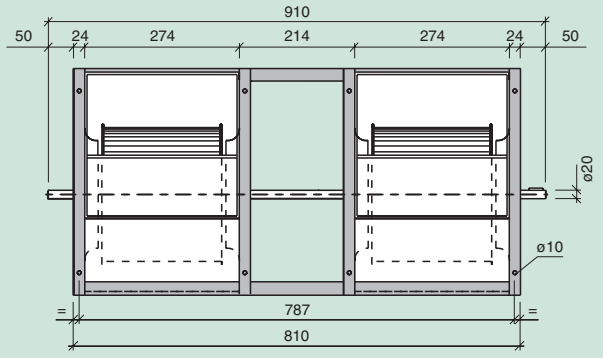

Serie

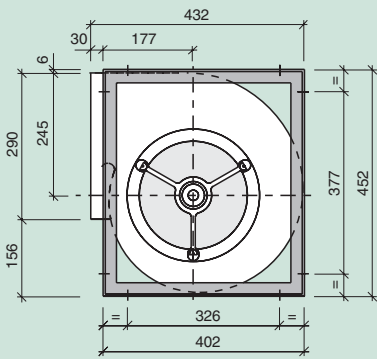

R

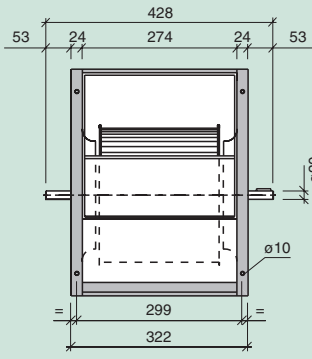

Serie

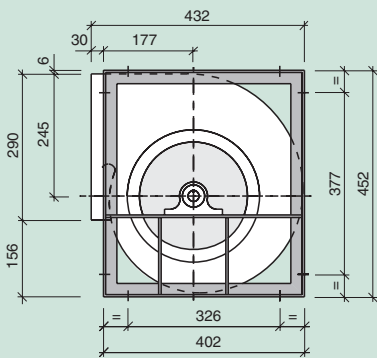

T2R

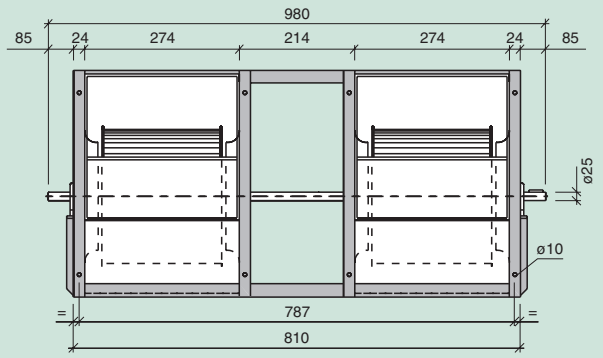

Serie - Series - Serie		L	SR	R	T2L	T2SR	T2R	T3R	
Límite de empleo. Operational limit. Limite d'emploi.	n max. motor max.	rpm kW	1700 1.5	1900 2	2200 3	1700 2	1900 3	2200 4.5	1700 6
Velocidad tangencial. Tip speed. Vitesse tangentielle.	u	m/s	n (min ⁻¹) x 0.0140						
Momento de inercia. Moment of inertia. Moment d'inertie.	PD ² /4	Kg m ²	0.05	0.05	0.05	0.09	0.09	0.09	0.14
Peso del ventilador. Fan weight. Poids du ventilateur.		Kg	9.5	12	13	22.5	25	28.5	55
Coefficientes de corrección. Correction factors. Coefficients de correction.	V P _A n	m ³ /h kW min ⁻¹	x 1 x 1 x 1	x 1 x 1 x 1	x 1 x 1 x 1	x 2 x 2.15 x 1.05	x 2 x 2.15 x 1.05	x 2 x 2.15 x 1.05	x 3 x 3.25 x 1.08

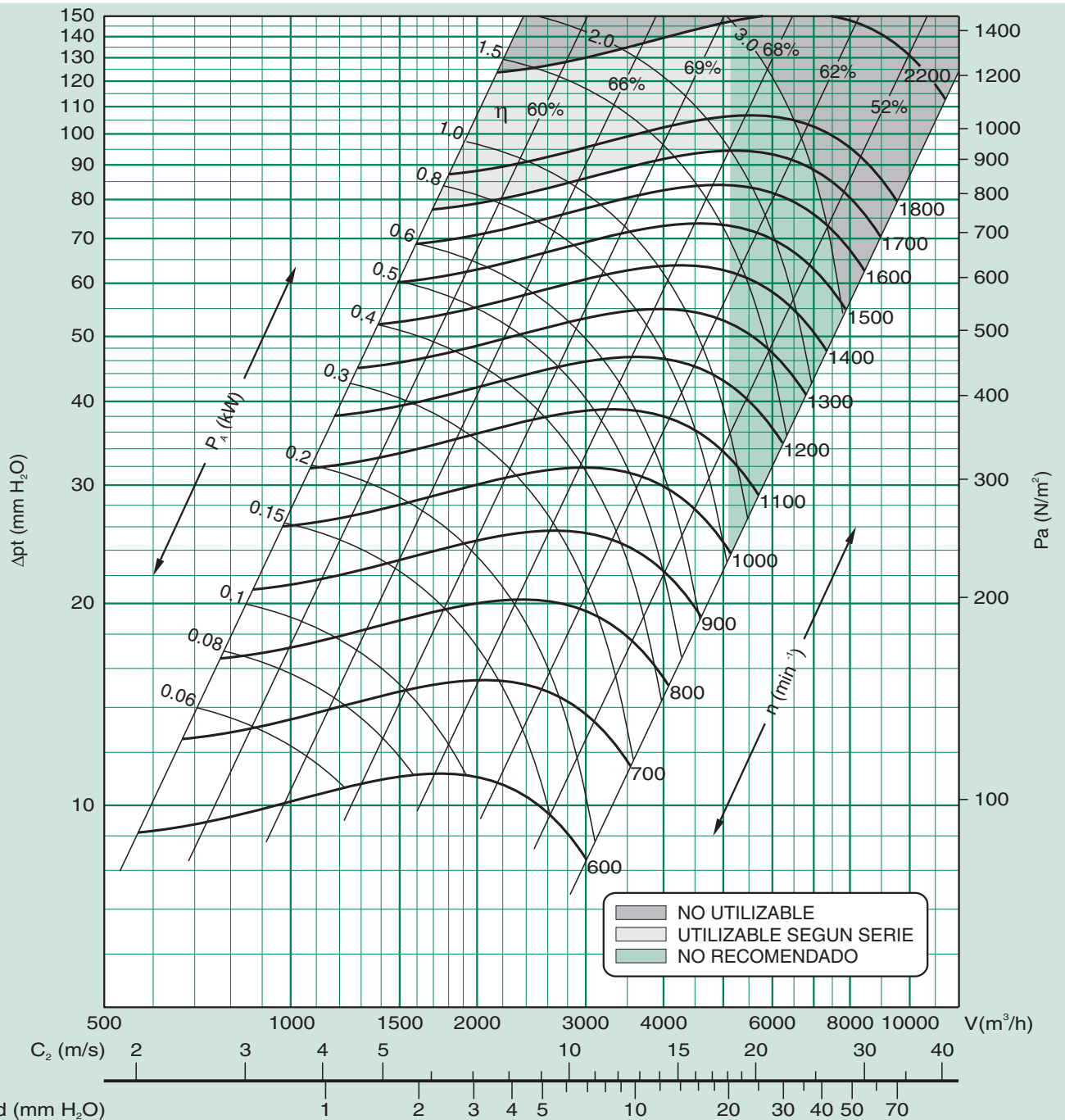

Serie

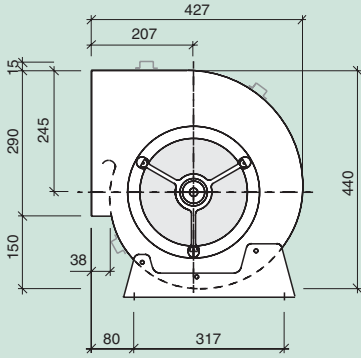

L

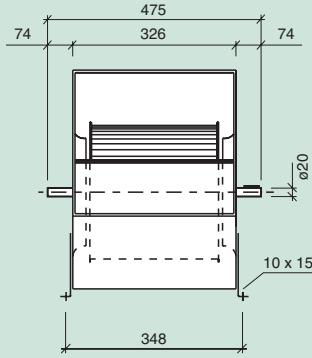

T2L

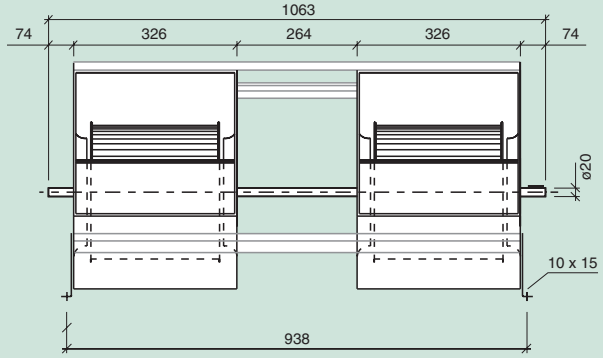

Serie

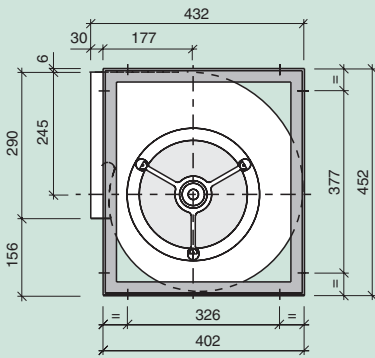

SR

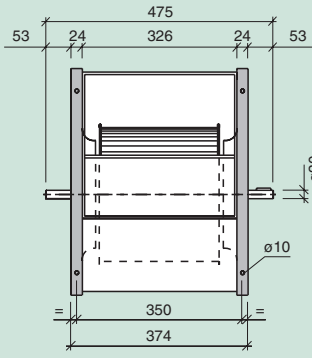

T2SR

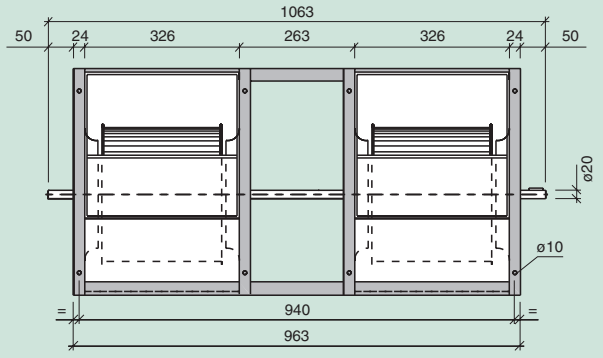

Serie

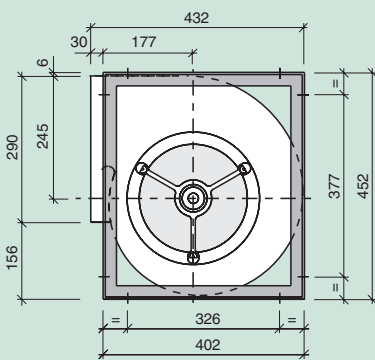

R

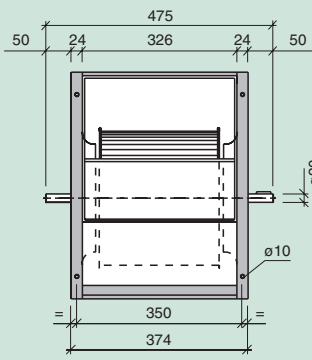

Serie

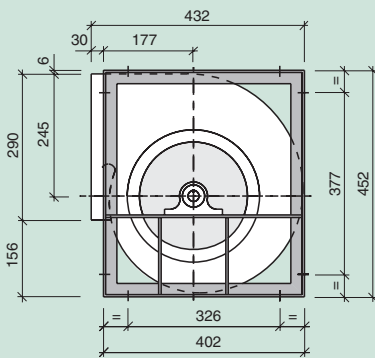

T2R

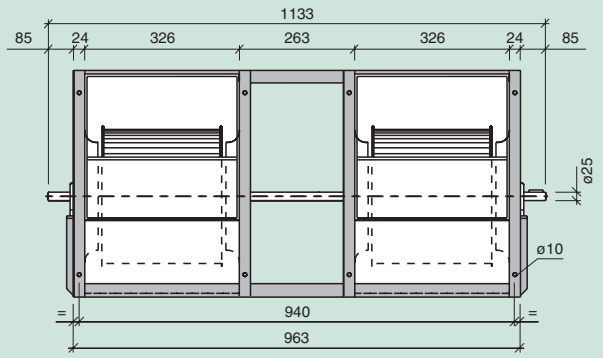

Serie - Series - Serie			L	SR	R	T2L	T2SR	T2R	T3R
Límite de empleo. Operational limit. Limite d'emploi.	n max. motor max.	rpm kW	1700 2	1900 2.5	2200 3	1700 2.5	1900 3	2200 4.5	1700 6
Velocidad tangencial. Tip speed. Vitesse tangentielle.	u	m/s	n (min ⁻¹) x 0.0140						
Momento de inercia. Moment of inertia. Moment d'inertie.	PD ² /4	Kg m ²	0.06	0.06	0.06	0.11	0.11	0.11	0.16
Peso del ventilador. Fan weight. Poids du ventilateur.		Kg	10.5	13.5	14	24.5	28	34	60
Coefficientes de corrección. Correction factors. Coefficients de correction.	V P _A n	m ³ /h kW min ⁻¹	x 1 x 1 x 1	x 1 x 1 x 1	x 1 x 1 x 1	x 2 x 2.15 x 1.05	x 2 x 2.15 x 1.05	x 2 x 2.15 x 1.05	x 3 x 3.25 x 1.08

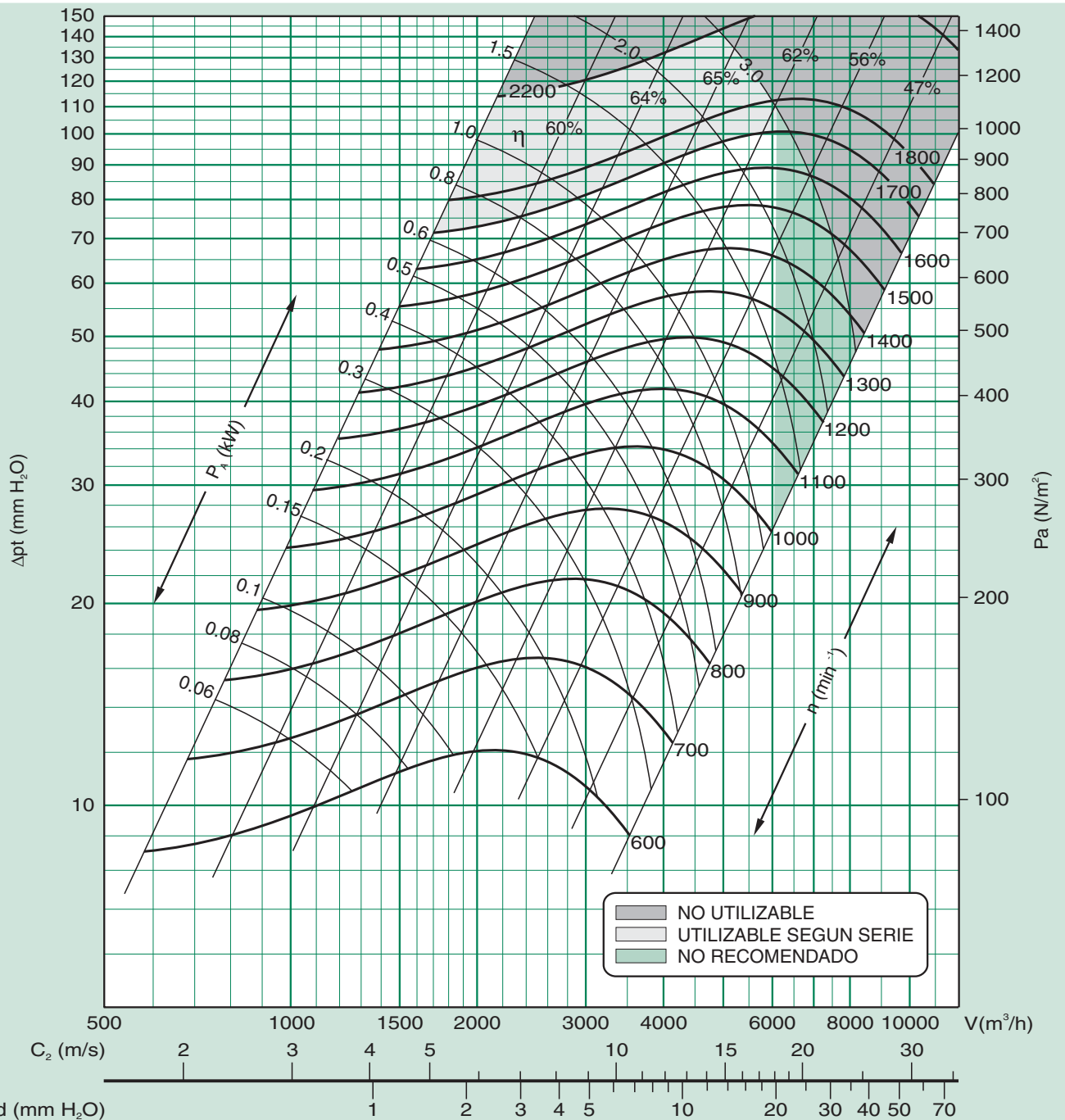

Serie

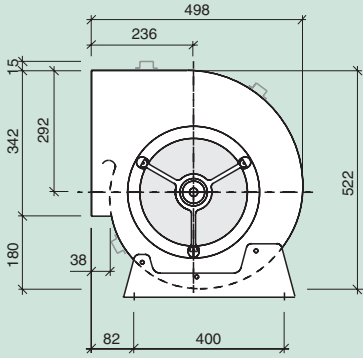

L

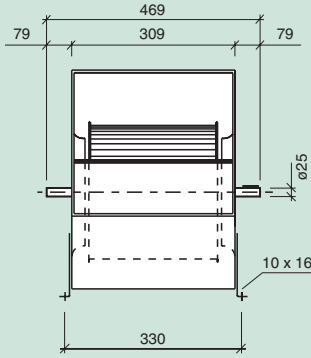

T2L

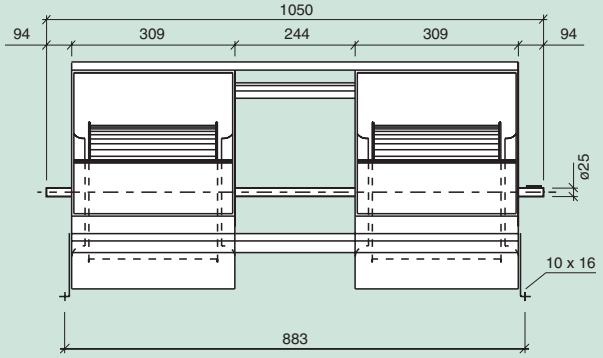

Serie

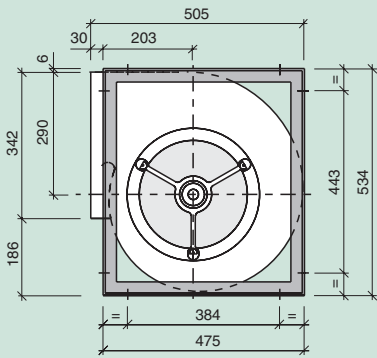

SR

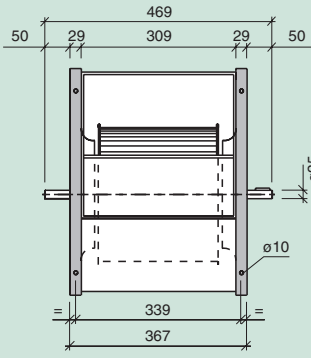

T2SR

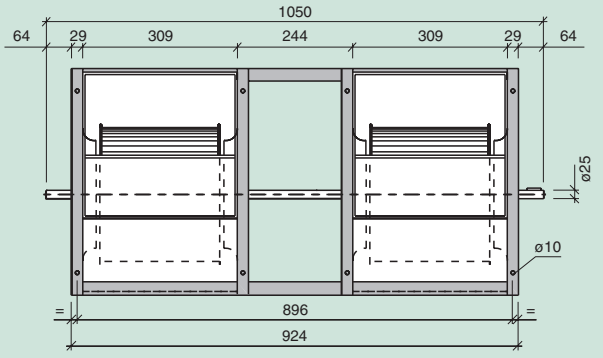

Serie

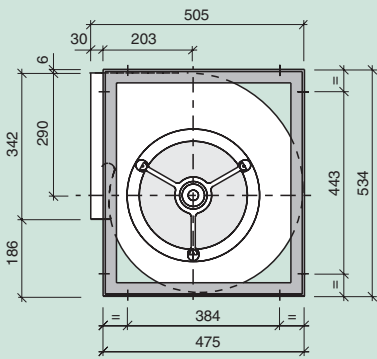

R

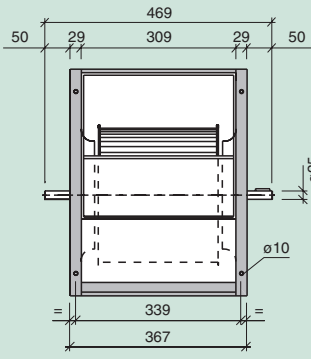

Serie

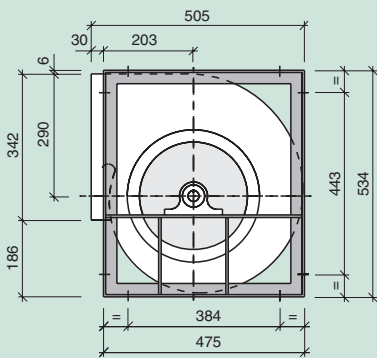

T2R

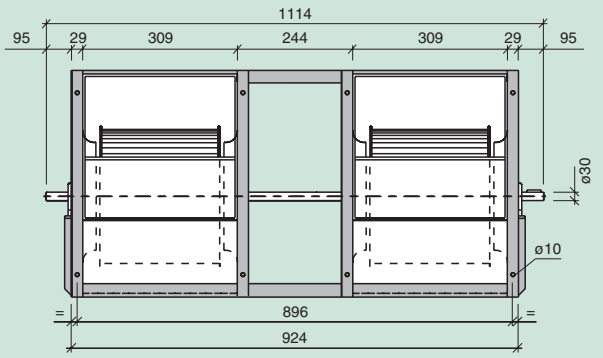

Serie - Series - Serie			L	SR	R	T2L	T2SR	T2R	T3R
Límite de empleo. Operational limit. Limite d'emploi.	n max. motor max.	rpm kW	1500 2.2	1600 3	1800 3.5	1400 3	1600 3.5	1800 5.5	1400 7
Velocidad tangencial. Tip speed. Vitesse tangentielle.	u	m/s	n (min ⁻¹) x 0.0169						
Momento de inercia. Moment of inertia. Moment d'inertie.	PD ² /4	Kg m ²	0.09	0.09	0.09	0.18	0.18	0.18	0.27
Peso del ventilador. Fan weight. Poids du ventilateur.		Kg	13.5	17	18	30	33	44.5	70
Coefficientes de corrección. Correction factors. Coefficients de correction.	V P _A n	m ³ /h kW min ⁻¹	x 1 x 1 x 1	x 1 x 1 x 1	x 1 x 1 x 1	x 2 x 2.15 x 1.05	x 2 x 2.15 x 1.05	x 2 x 2.15 x 1.05	x 3 x 3.25 x 1.08

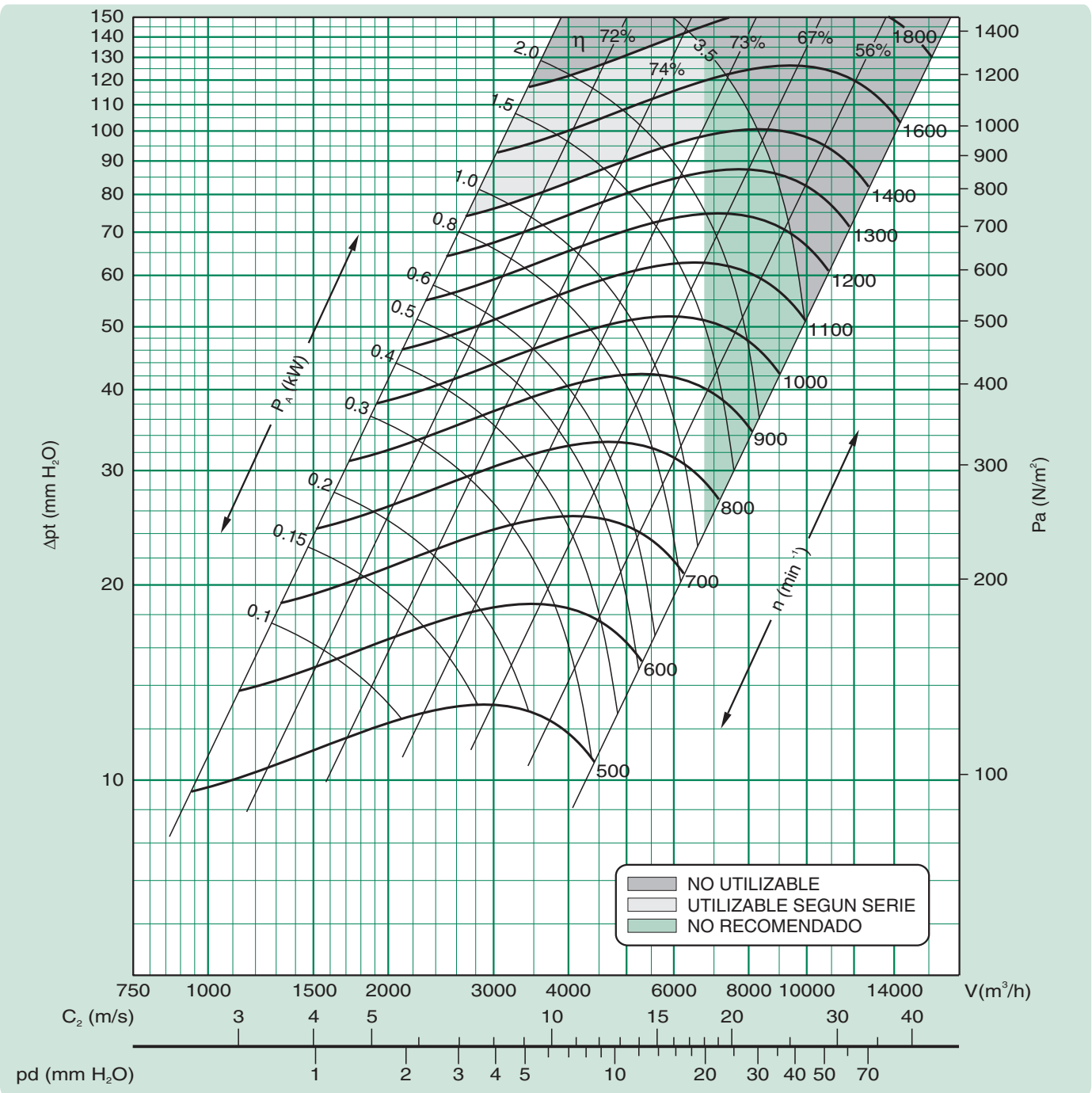

Serie

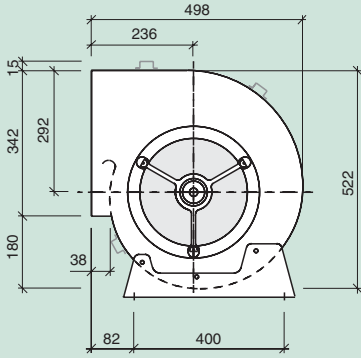

L

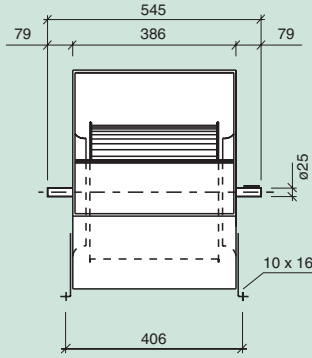

T2L

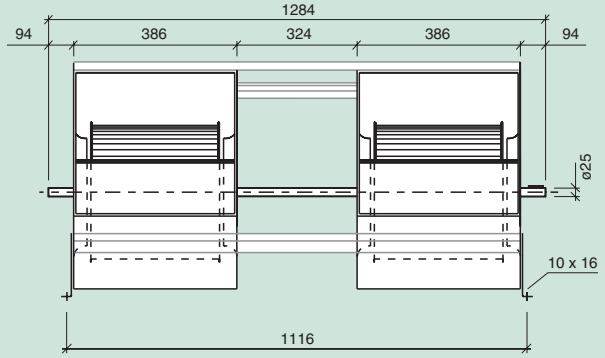

Serie

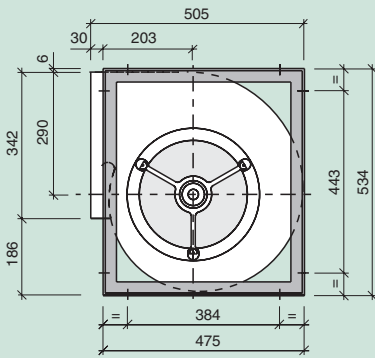

SR

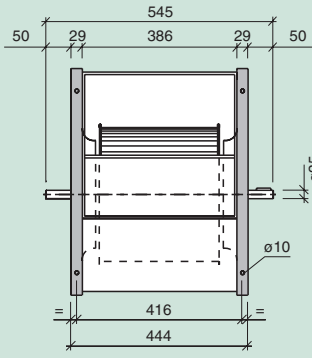

T2SR

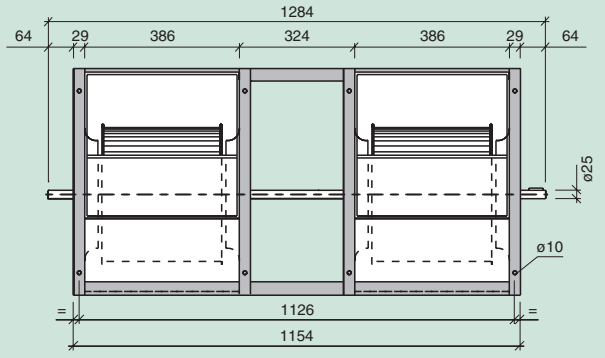

Serie

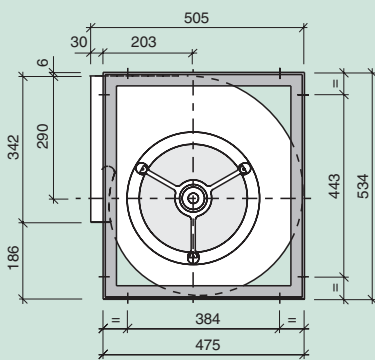

R

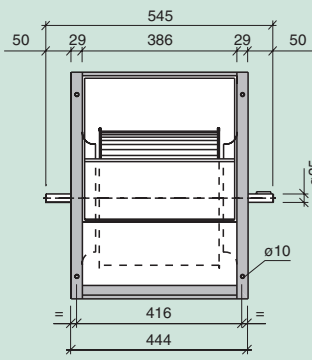

Serie

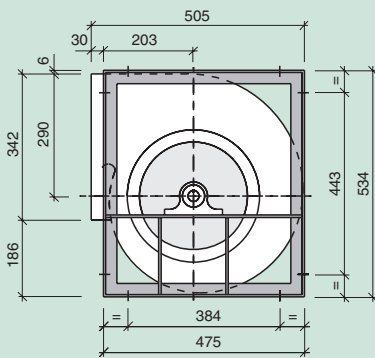

T2R

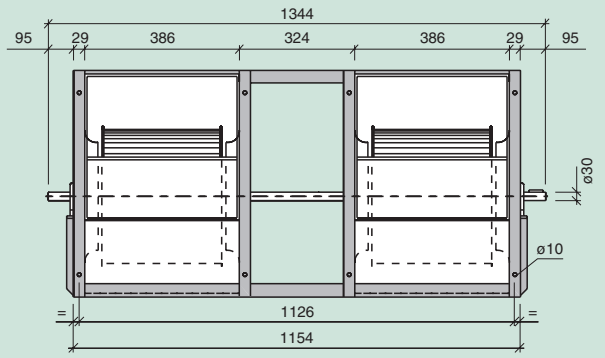

Serie - Series - Serie			L	SR	R	T2L	T2SR	T2R	T3R
Límite de empleo. Operational limit. Limite d'emploi.	n max. motor max.	rpm kW	1500 3	1600 3	1800 3.5	1400 3	1600 3.5	1800 5.5	1400 7
Velocidad tangencial. Tip speed. Vitesse tangentielle.	u	m/s	n (min ⁻¹) x 0.0169						
Momento de inercia. Moment of inertia. Moment d'inertie.	PD ² /4	Kg m ²	0.11	0.11	0.11	0.22	0.22	0.22	0.33
Peso del ventilador. Fan weight. Poids du ventilateur.		Kg	15.5	18.5	19.5	34	40	52	80
Coefficientes de corrección. Correction factors. Coefficients de correction.	V P _A n	m ³ /h kW min ⁻¹	x 1 x 1 x 1	x 1 x 1 x 1	x 1 x 1 x 1	x 2 x 2.15 x 1.05	x 2 x 2.15 x 1.05	x 2 x 2.15 x 1.05	x 3 x 3.25 x 1.08

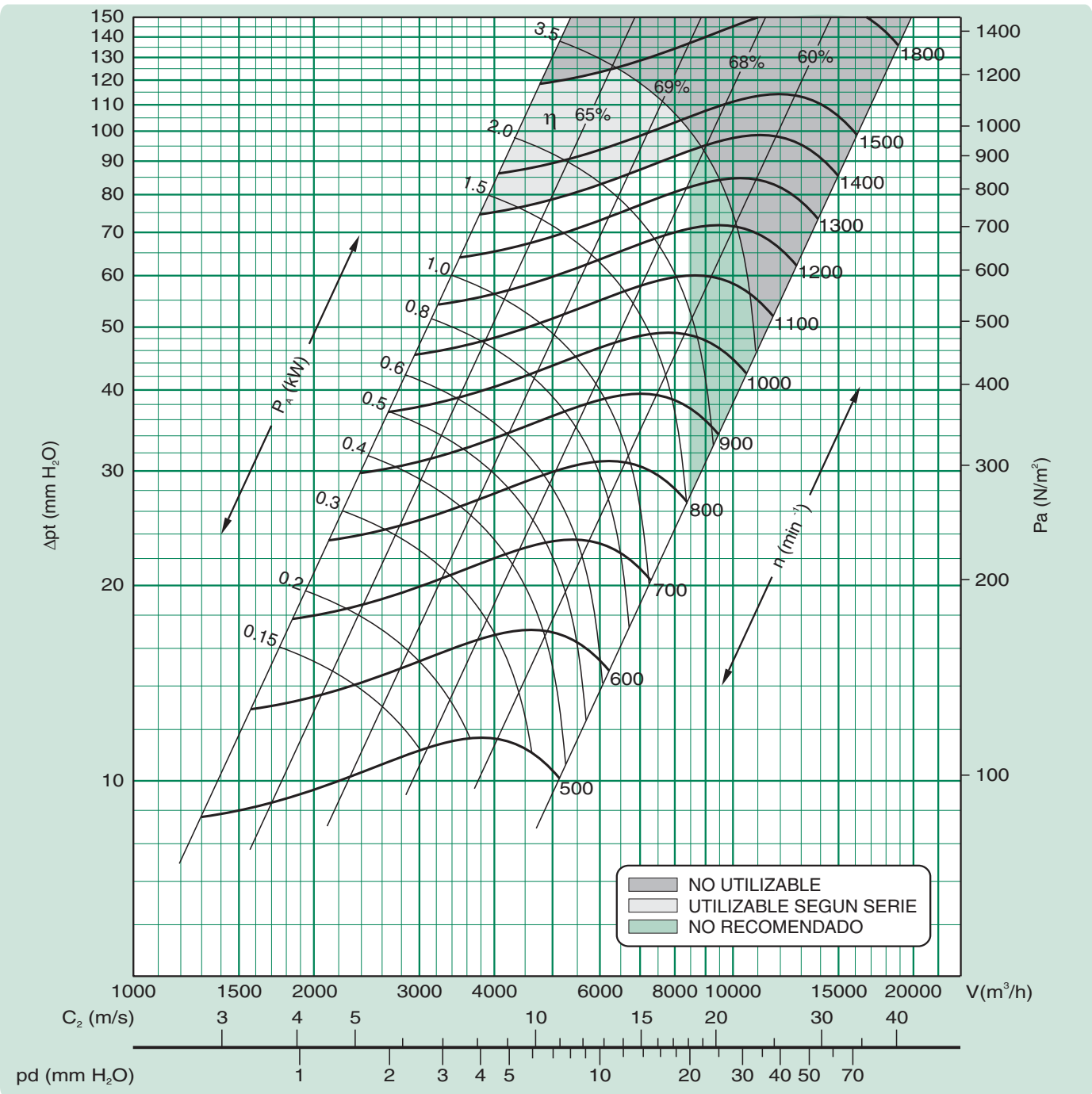

Serie

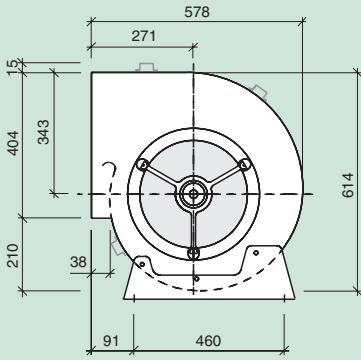

L

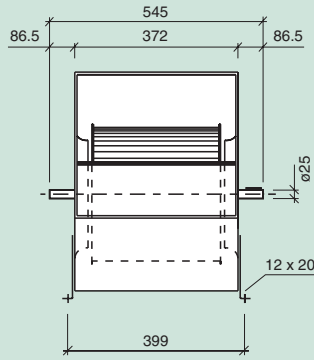

T2L

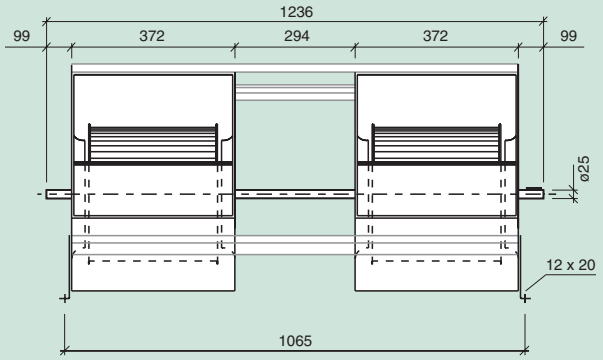

Serie

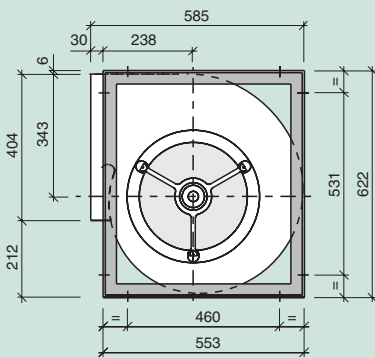

SR

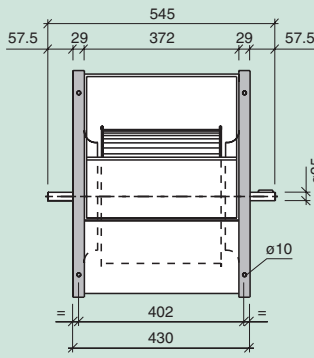

T2SR

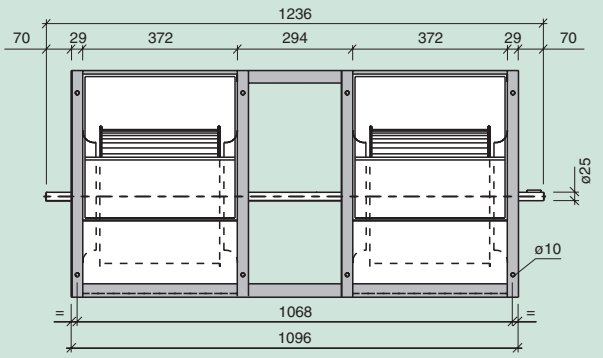

Serie

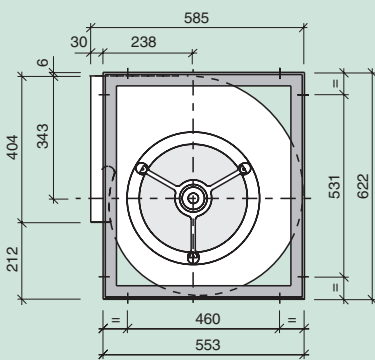

R

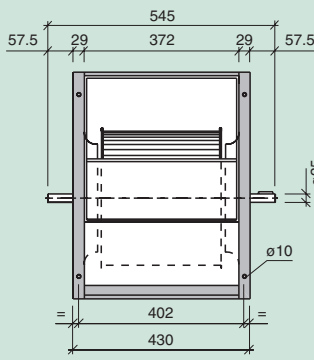

Serie

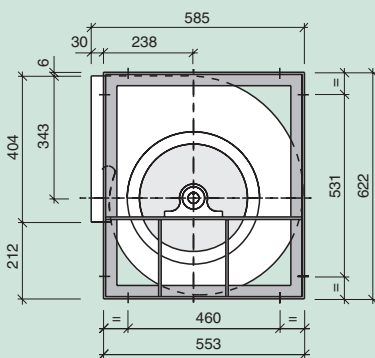

T2R

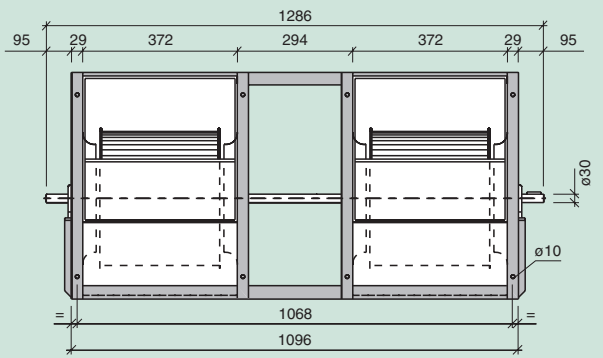

Serie - Series - Serie		L	SR	R	T2L	T2SR	T2R	T3R	
Límite de empleo. <i>Operational limit.</i> Limite d'emploi.	n max. motor max.	rpm kW	1200 3	1300 4	1400 5	1100 4	1200 5	1300 6	1100 8
Velocidad tangencial. <i>Tip speed.</i> Vitesse tangentielle.	u	m/s	n (min ⁻¹) x 0.0203						
Momento de inercia. <i>Moment of inertia.</i> Moment d'inertie.	PD ² /4	Kg m ²	0.23	0.23	0.23	0.46	0.46	0.46	0.69
Peso del ventilador. <i>Fan weight.</i> Poids du ventilateur.		Kg	20.5	23.5	24.5	44.5	45	61	95
Coefficientes de corrección. <i>Correction factors.</i> Coefficients de correction.	V P _A n	m ³ /h kW min ⁻¹	x 1 x 1 x 1	x 1 x 1 x 1	x 1 x 1 x 1	x 2 x 2.15 x 1.05	x 2 x 2.15 x 1.05	x 2 x 2.15 x 1.05	x 3 x 3.25 x 1.08

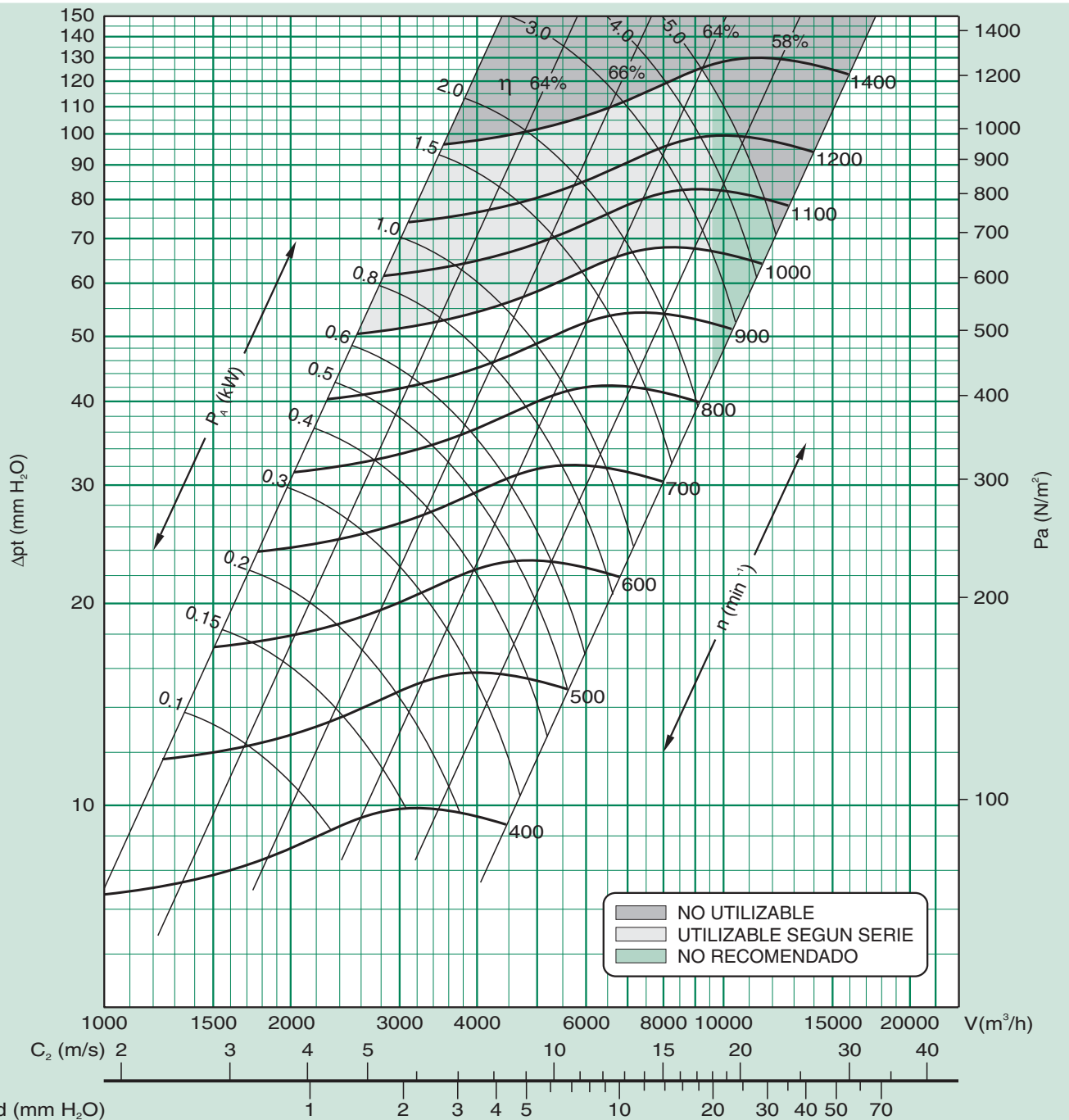

Serie

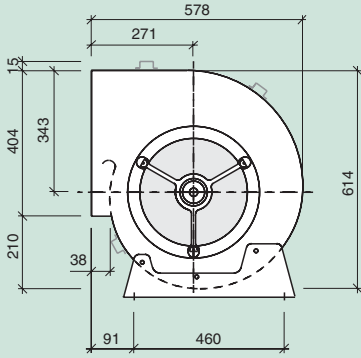

L

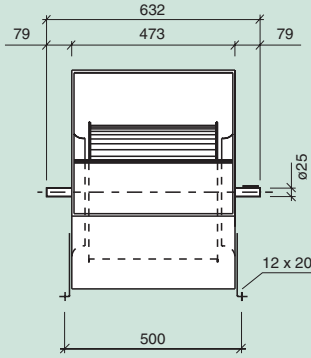

T2L

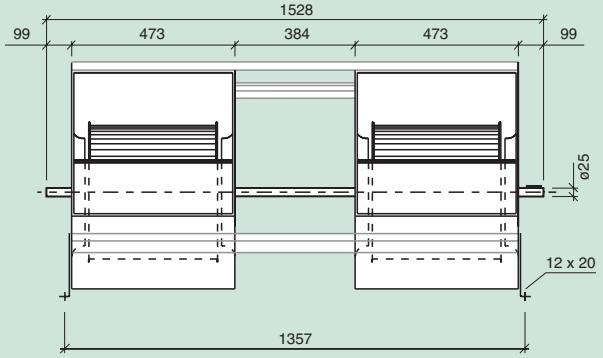

Serie

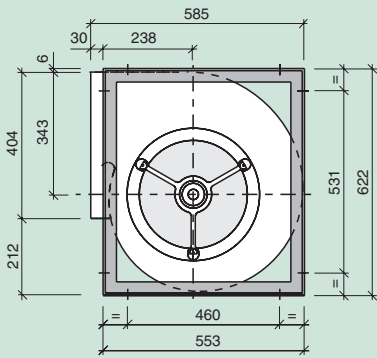

SR

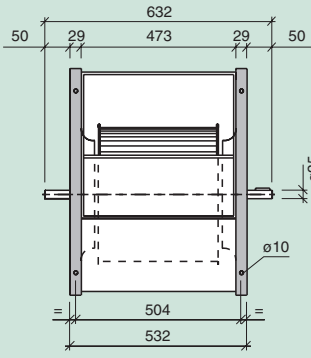

T2SR

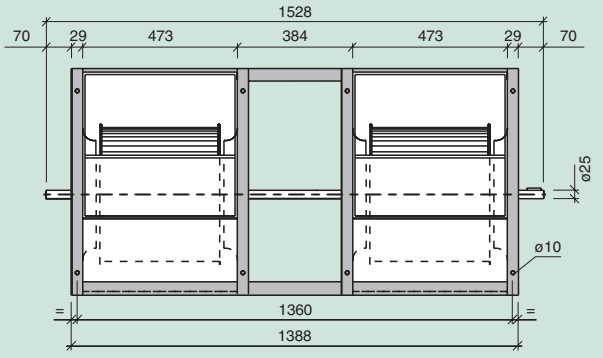

Serie

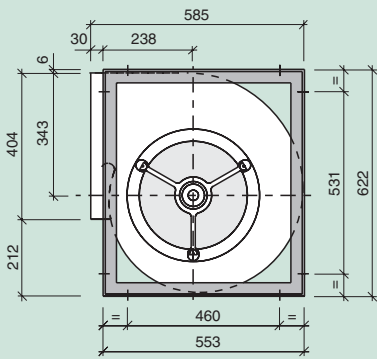

R

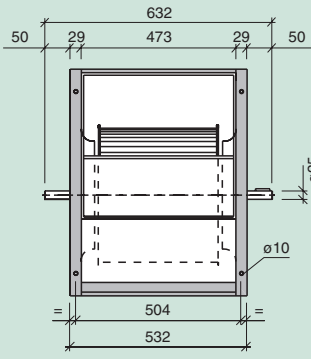

Serie

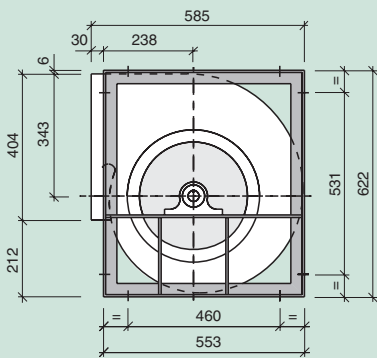

T2R

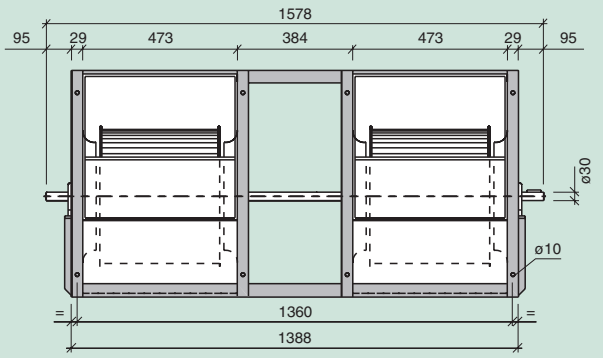

Serie - Series - Serie			L	SR	R	T2L	T2SR	T2R	T3R
Límite de empleo. Operational limit. Limite d'emploi.	n max. motor max.	rpm kW	1200 4	1300 4.5	1400 5.5	1000 5.5	1100 6	1200 8	1100 9
Velocidad tangencial. Tip speed. Vitesse tangentielle.	u	m/s	n (min ⁻¹) x 0.0203						
Momento de inercia. Moment of inertia. Moment d'inertie.	PD ² /4	Kg m ²	0.27	0.27	0.27	0.54	0.54	0.54	0.80
Peso del ventilador. Fan weight. Poids du ventilateur.		Kg	24	27.5	28.5	52.5	60	71	115
Coefficientes de corrección. Correction factors. Coefficients de correction.	V P _A n	m ³ /h kW min ⁻¹	x 1 x 1 x 1	x 1 x 1 x 1	x 1 x 1 x 1	x 2 x 2.15 x 1.05	x 2 x 2.15 x 1.05	x 2 x 2.15 x 1.05	x 3 x 3.25 x 1.08

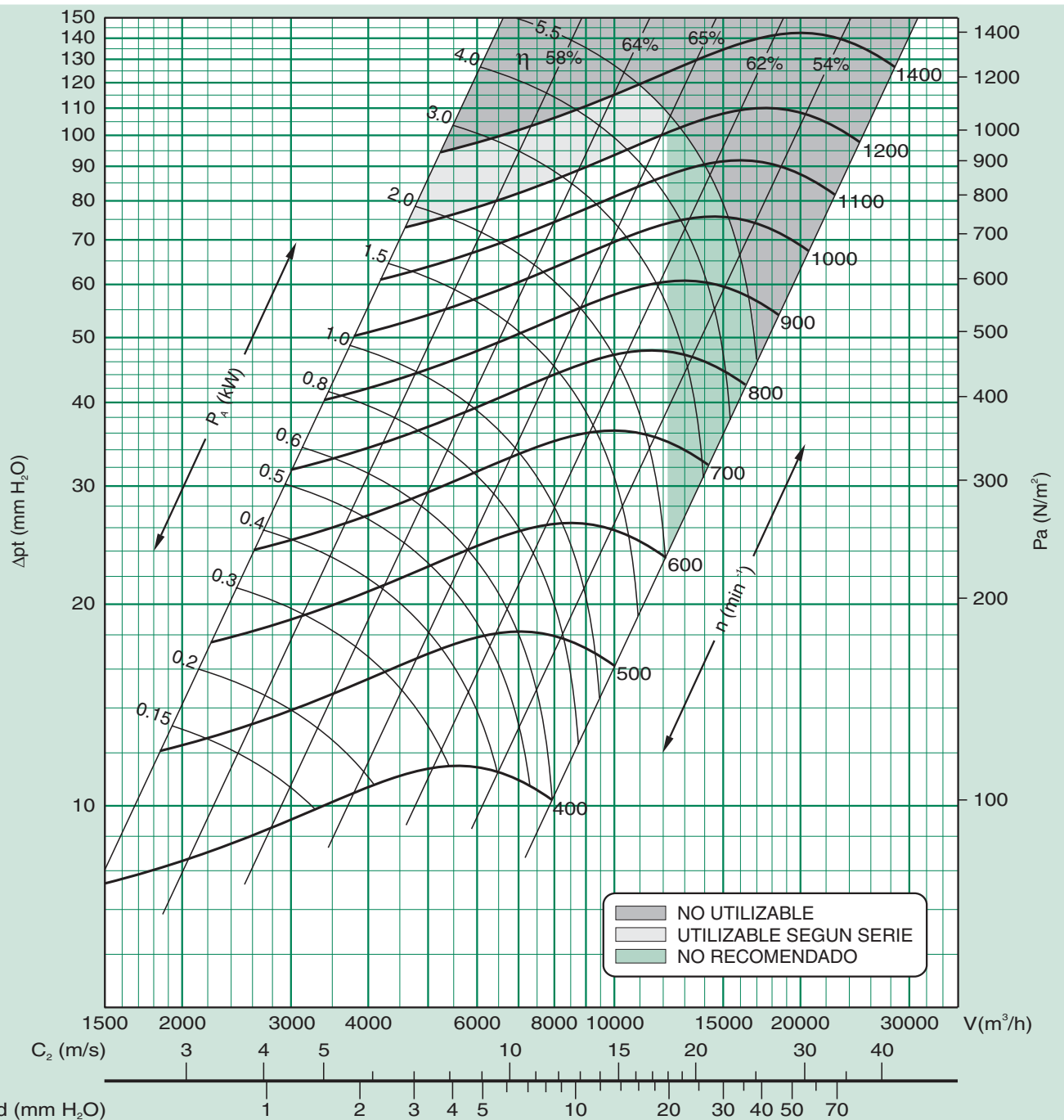

Serie

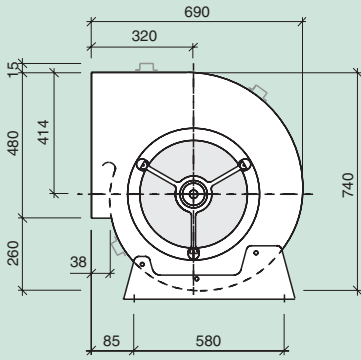

L

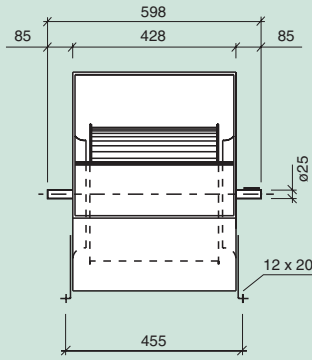

T2L

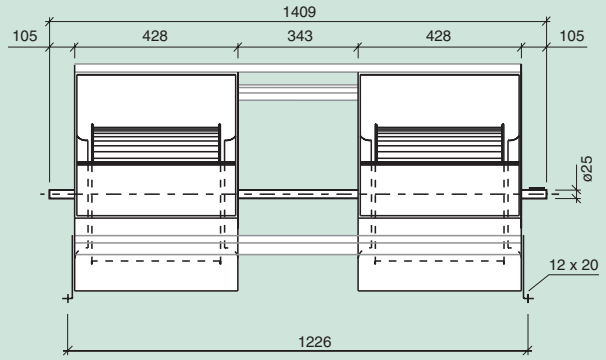

Serie

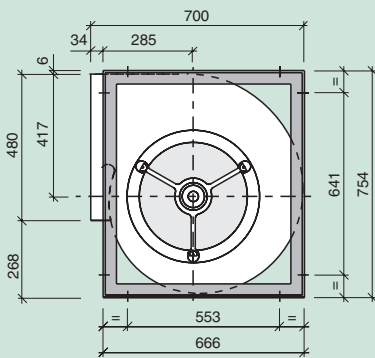

SR

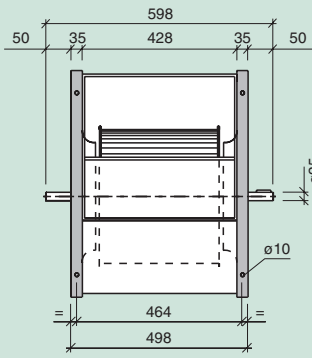

T2SR

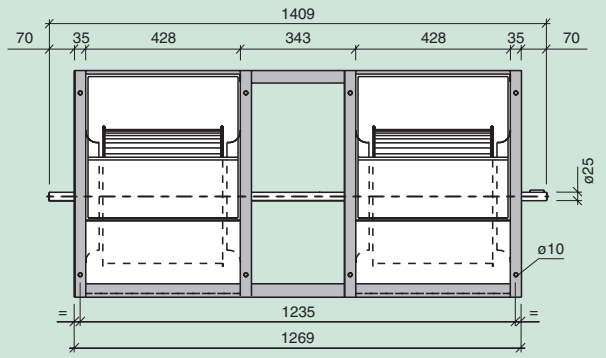

Serie

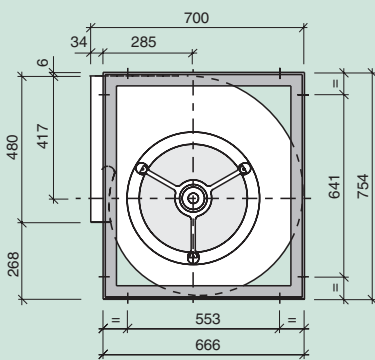

R

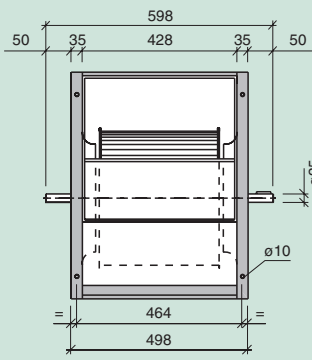

Serie

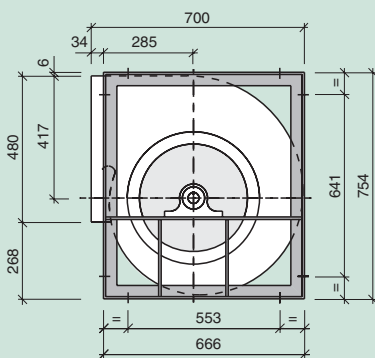

T2R

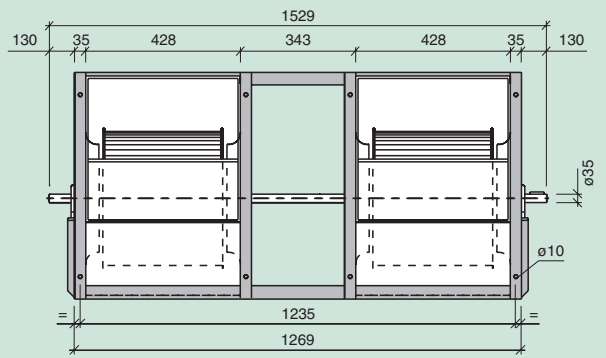

Serie - Series - Serie		L	SR	R	T2L	T2SR	T2R	T3R	
Límite de empleo. Operational limit. Limite d'emploi.	n max. motor max.	rpm kW	1000 5	1100 5.5	1200 6	900 6	1000 7	1100 9	900 13
Velocidad tangencial. Tip speed. Vitesse tangentielle.	u	m/s	n (min ⁻¹) x 0.0241						
Momento de inercia. Moment of inertia. Moment d'inertie.	PD ² /4	Kg m ²	0.46	0.46	0.46	0.92	0.92	0.92	1.38
Peso del ventilador. Fan weight. Poids du ventilateur.		Kg	28	33	34.5	61.5	72	84	143
Coefficientes de corrección. Correction factors. Coefficients de correction.	V P _A n	m ³ /h kW min ⁻¹	x 1 x 1 x 1	x 1 x 1 x 1	x 1 x 1 x 1	x 2 x 2.15 x 1.05	x 2 x 2.15 x 1.05	x 2 x 2.15 x 1.05	x 3 x 3.25 x 1.08

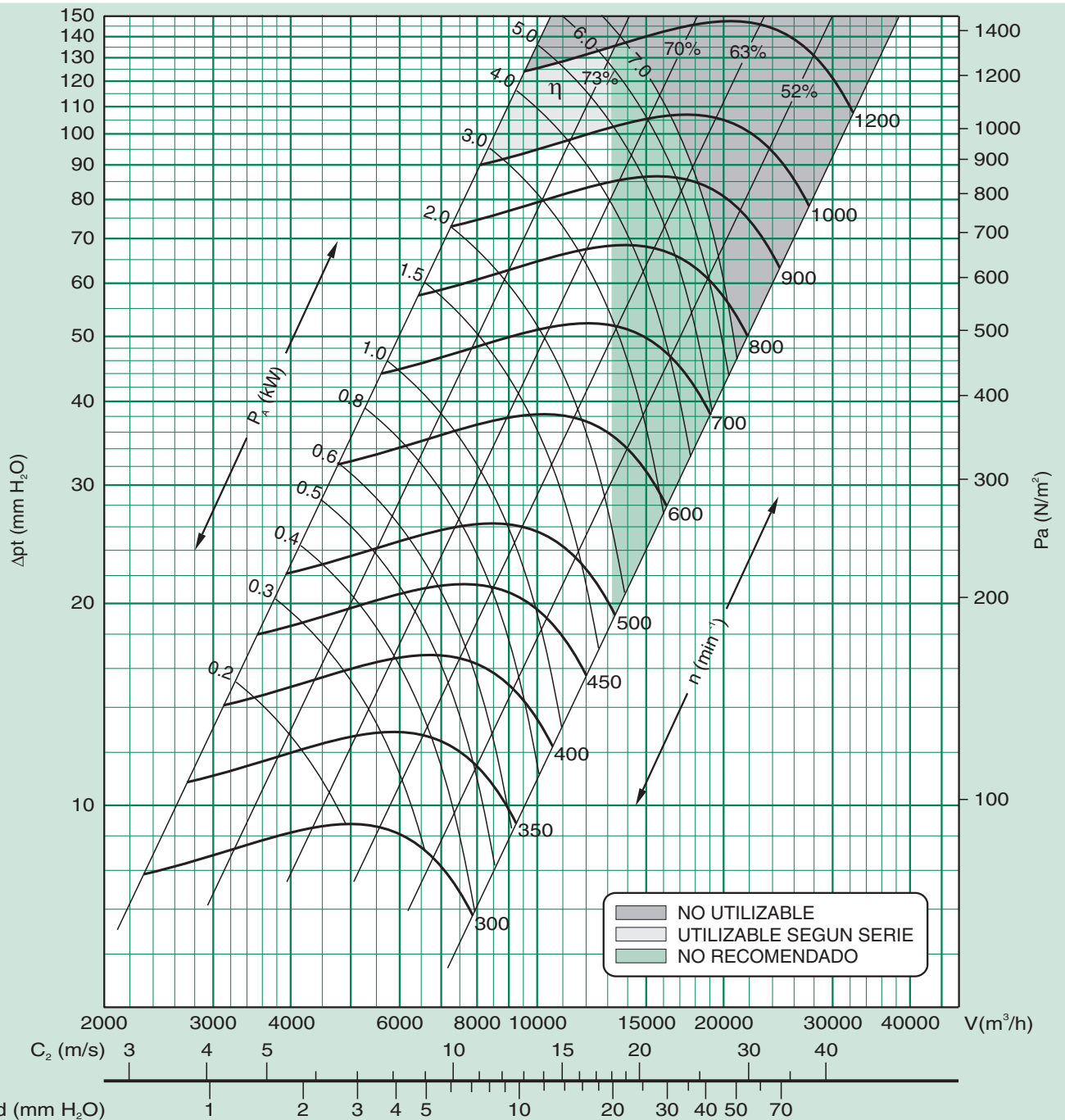

Serie

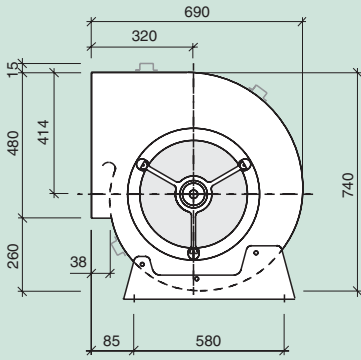

L

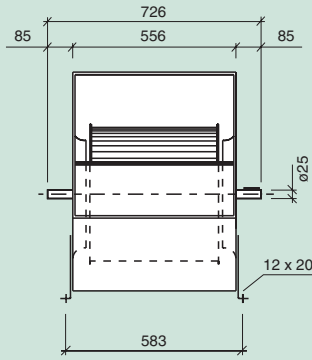

T2L

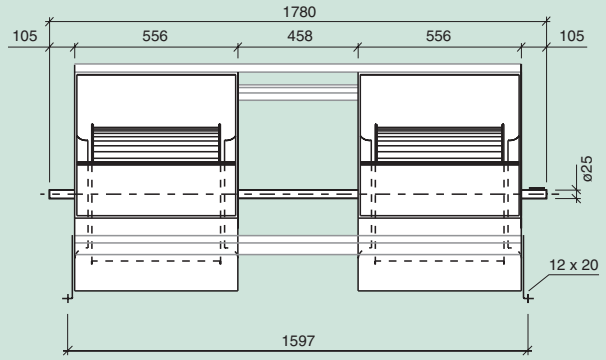

Serie

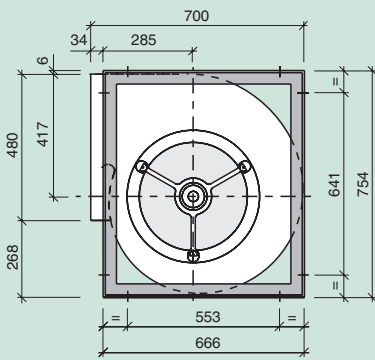

SR

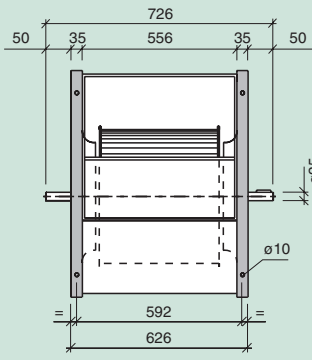

T2SR

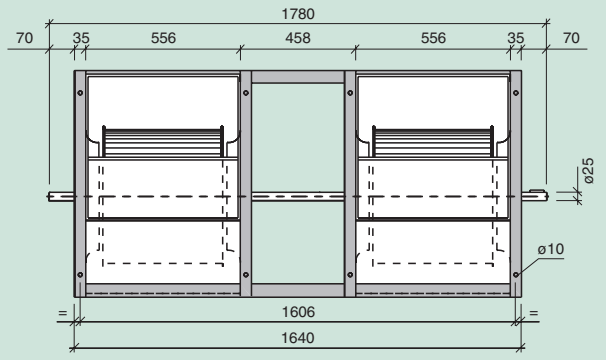

Serie

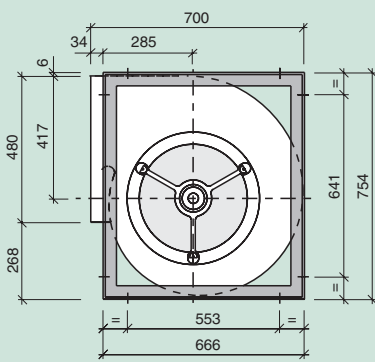

R

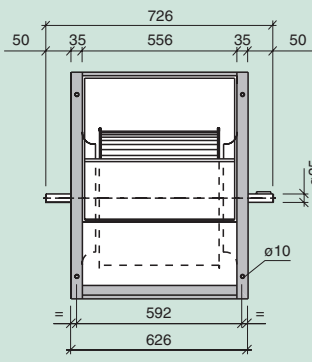

Serie

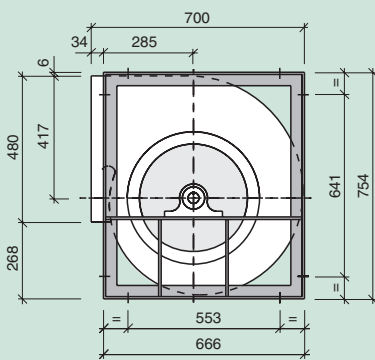

T2R

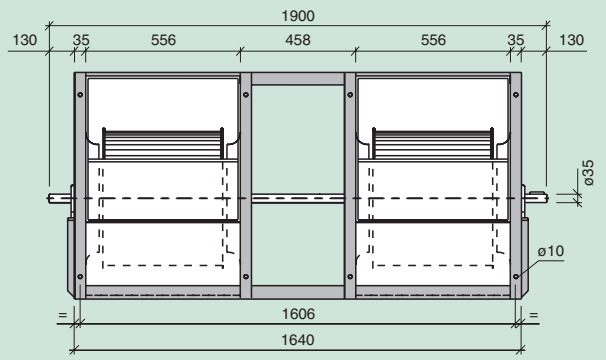

Serie - Series - Serie			L	SR	R	T2L	T2SR	T2R	T3R
Límite de empleo. Operational limit. Limite d'emploi.	n max. motor max.	rpm kW	1000 5	1100 6	1200 7	900 6	1000 7	1100 11	900 13
Velocidad tangencial. Tip speed. Vitesse tangentielle.	u	m/s	n (min ⁻¹) x 0.0241						
Momento de inercia. Moment of inertia. Moment d'inertie.	PD ² /4	Kg m ²	0.59	0.59	0.59	1.18	1.18	1.18	1.77
Peso del ventilador. Fan weight. Poids du ventilateur.		Kg	33.5	38.5	40	73	82	97	163
Coefficientes de corrección. Correction factors. Coefficients de correction.	V P _A n	m ³ /h kW min ⁻¹	x 1 x 1 x 1	x 1 x 1 x 1	x 1 x 1 x 1	x 2 x 2.15 x 1.05	x 2 x 2.15 x 1.05	x 2 x 2.15 x 1.05	x 3 x 3.25 x 1.08

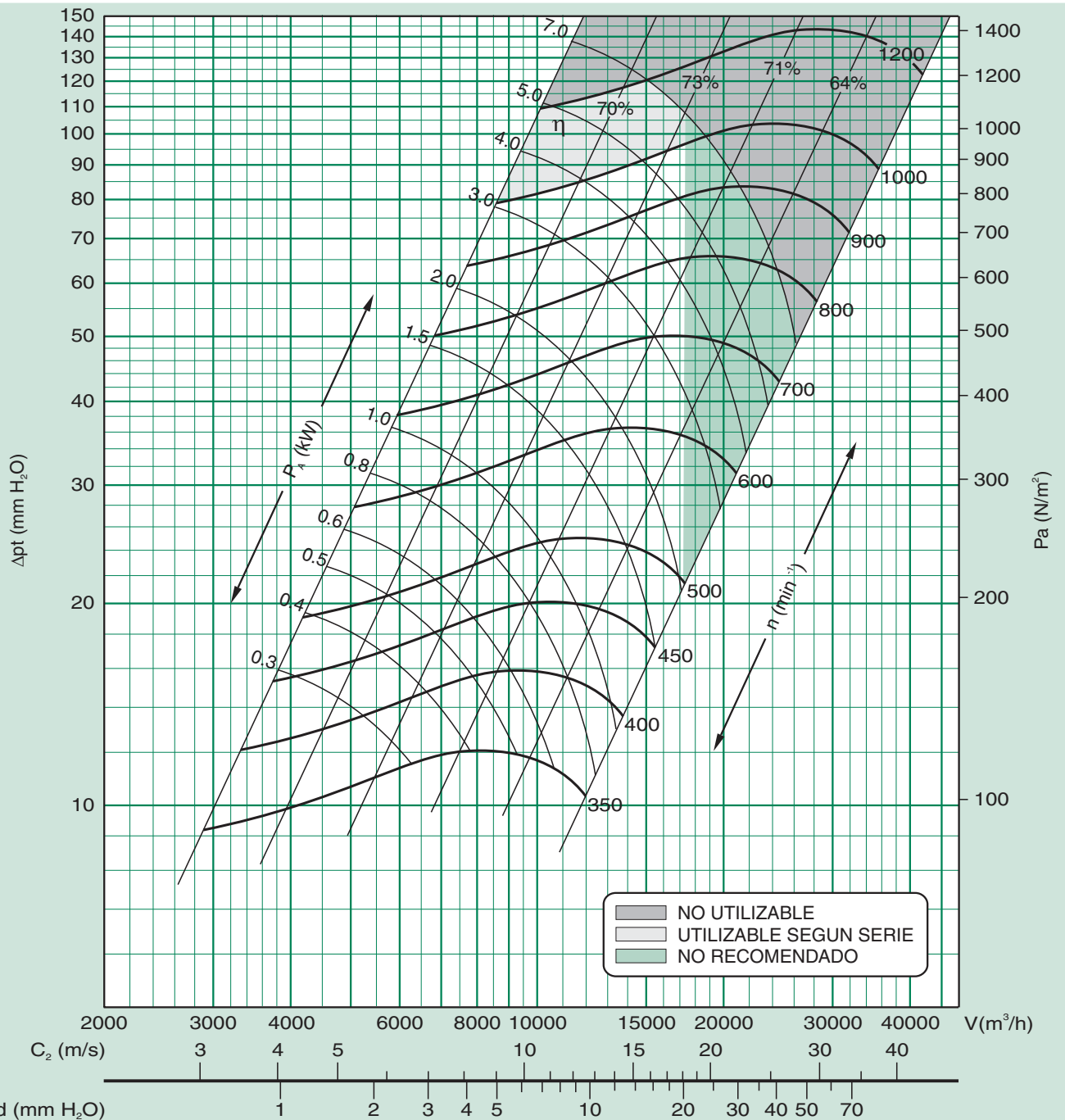

Serie

SR

Solamente en orientaciones

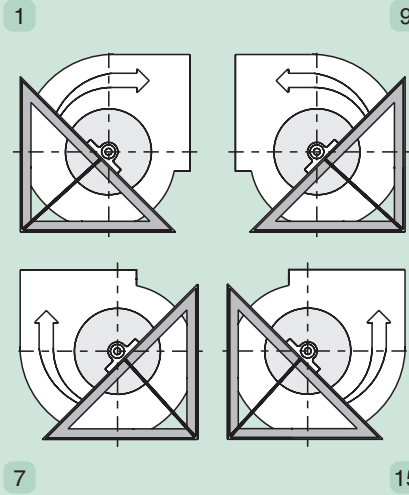
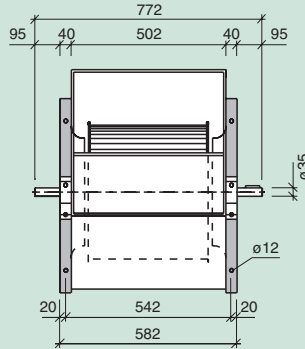
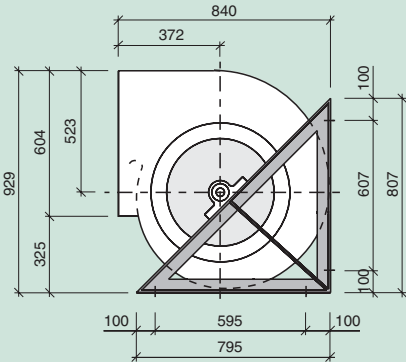

Serie

R

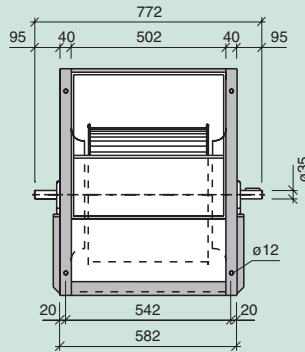
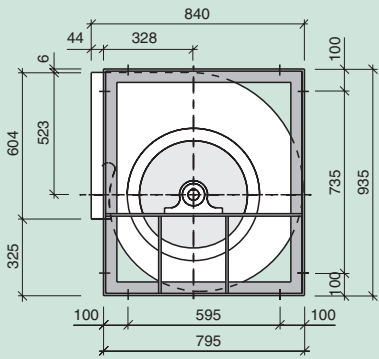

Serie

T2R

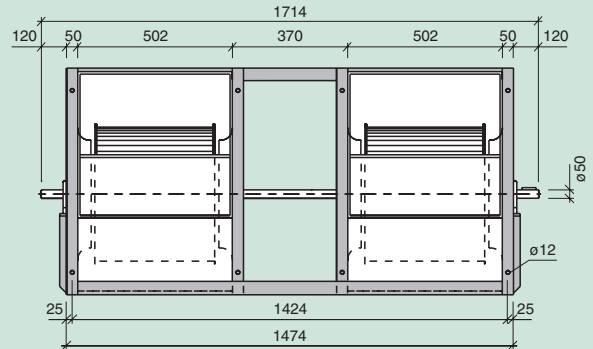
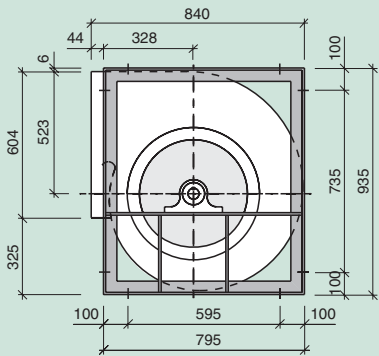

Serie - Series - Serie			SR	R		T2R	T3R
Límite de empleo. Operational limit. Limite d'emploi.	n max. motor max.	rpm kW	900 7.5	900 7.5		950 17	900 20
Velocidad tangencial. Tip speed. Vitesse tangentielle.	u	m/s	n (min ⁻¹) x 0.0288				
Momento de inercia. Moment of inertia. Moment d'inertie.	PD ² /4	Kg m ²	0.99	0.99		1.98	2.97
Peso del ventilador. Fan weight. Poids du ventilateur.		Kg	63	72		170	275
Coefficientes de corrección. Correction factors. Coefficients de correction.	V P _A n	m ³ /h kW min ⁻¹	x 1 x 1 x 1	x 1 x 1 x 1		x 2 x 2.15 x 1.05	x 3 x 3.25 x 1.08

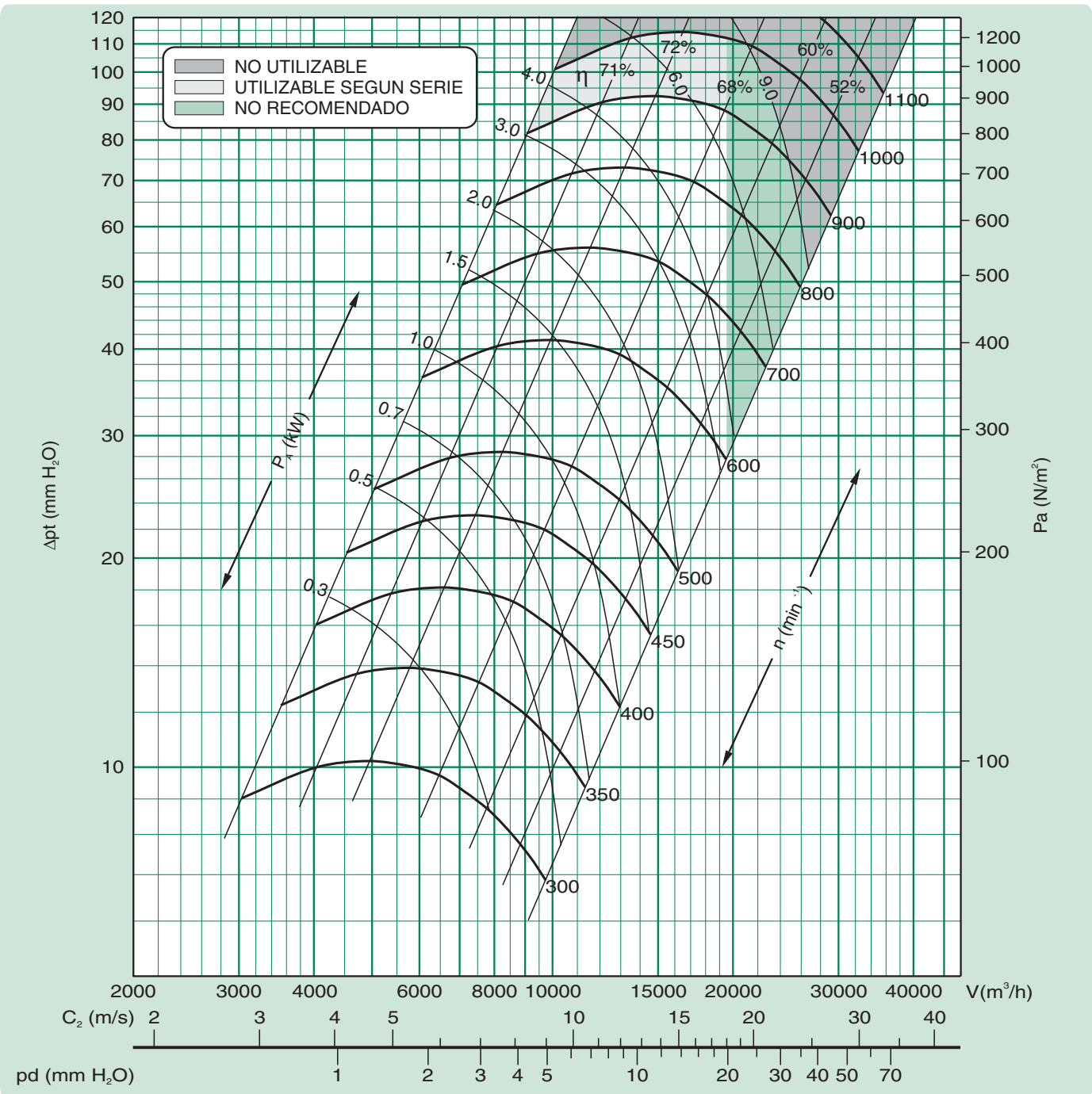

Serie

SR

Solamente en orientaciones

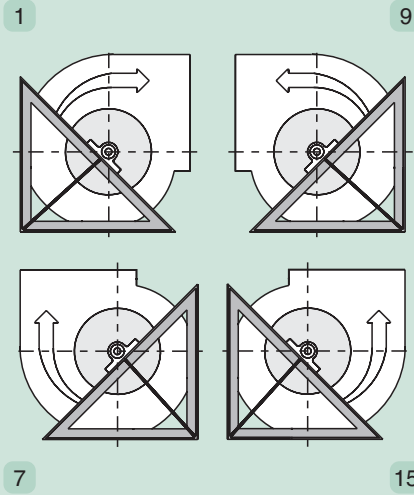
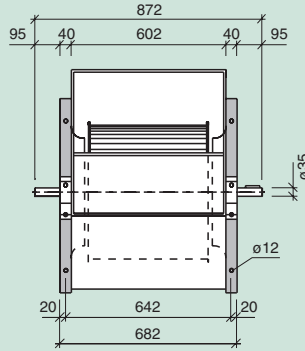
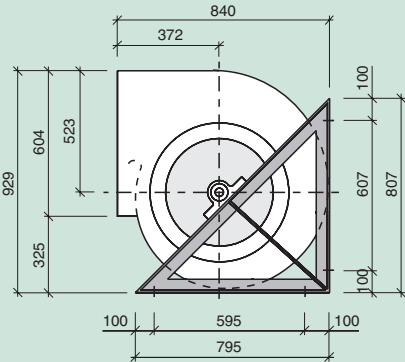

Serie

R

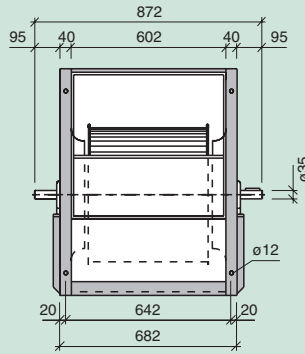
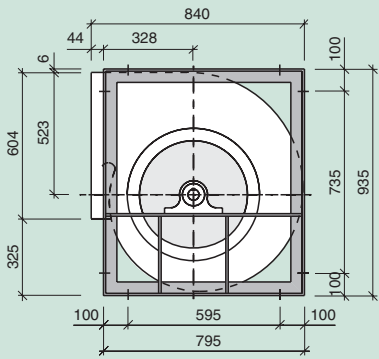

Serie

T2R

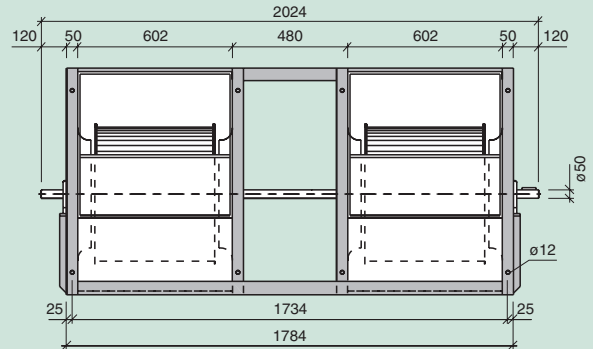
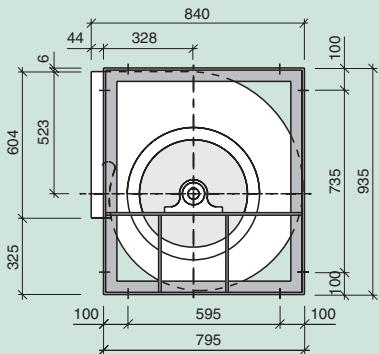

Serie - Series - Serie			SR	R		T2R	T3R
Límite de empleo. Operational limit. Limite d'emploi.	n max. motor max.	rpm kW	800 7.5	900 9		950 17	900 20
Velocidad tangencial. Tip speed. Vitesse tangentielle.	u	m/s	n (min ⁻¹) x 0.0288				
Momento de inercia. Moment of inertia. Moment d'inertie.	PD ² /4	Kg m ²	1.14	1.14		2.27	3.41
Peso del ventilador. Fan weight. Poids du ventilateur.		Kg	75.5	84		195	315
Coefficientes de corrección. Correction factors. Coefficients de correction.	V P _A n	m ³ /h kW min ⁻¹	x 1 x 1 x 1	x 1 x 1 x 1		x 2 x 2.15 x 1.05	x 3 x 3.25 x 1.08

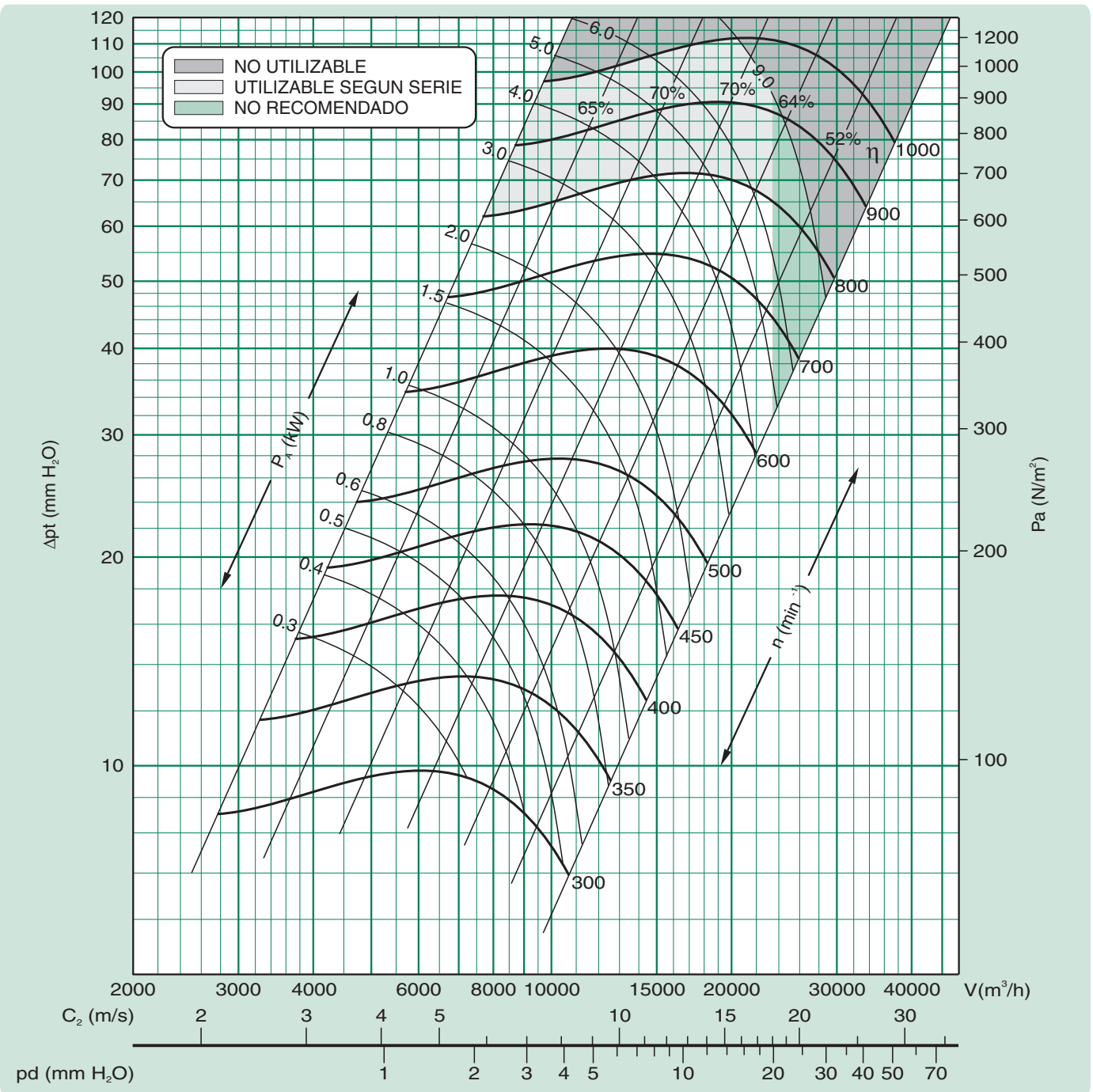

Serie

SR

Solamente en orientaciones

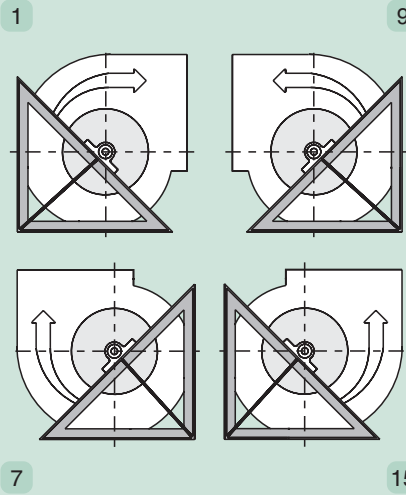
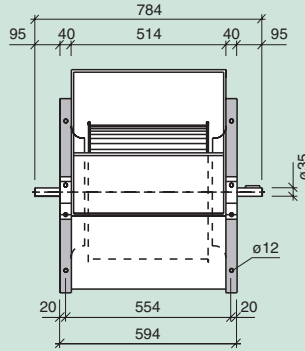
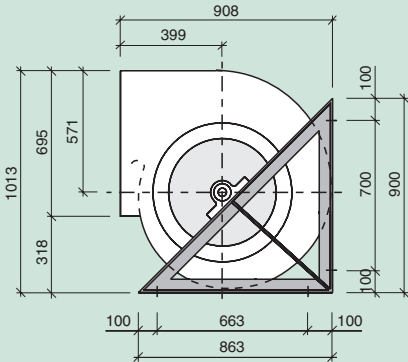

Serie

R

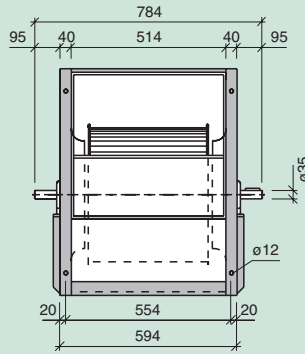
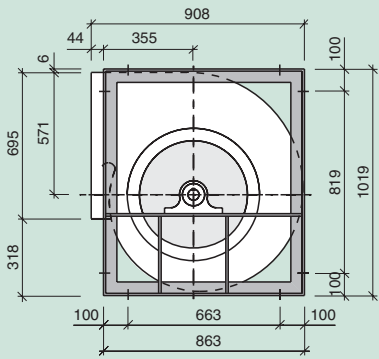

Serie

T2R

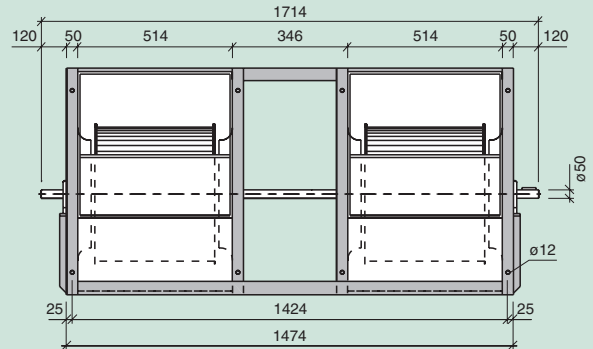
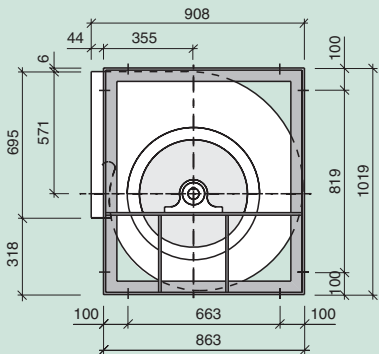

Serie - Series - Serie		SR	R	T2R	T3R	
Límite de empleo. Operational limit. Limite d'emploi.	n max. motor max.	rpm kW	800 8	900 11.5	850 20	800 23
Velocidad tangencial. Tip speed. Vitesse tangentielle.	u	m/s	n (min ⁻¹) x 0.0314			
Momento de inercia. Moment of inertia. Moment d'inertie.	PD ² /4	Kg m ²	1.47	1.47	2.94	4.41
Peso del ventilador. Fan weight. Poids du ventilateur.		Kg	66	76	180	289
Coefficientes de corrección. Correction factors. Coefficients de correction.	V P _A n	m ³ /h kW min ⁻¹	x 1 x 1 x 1	x 1 x 1 x 1	x 2 x 2.15 x 1.05	x 3 x 3.25 x 1.08

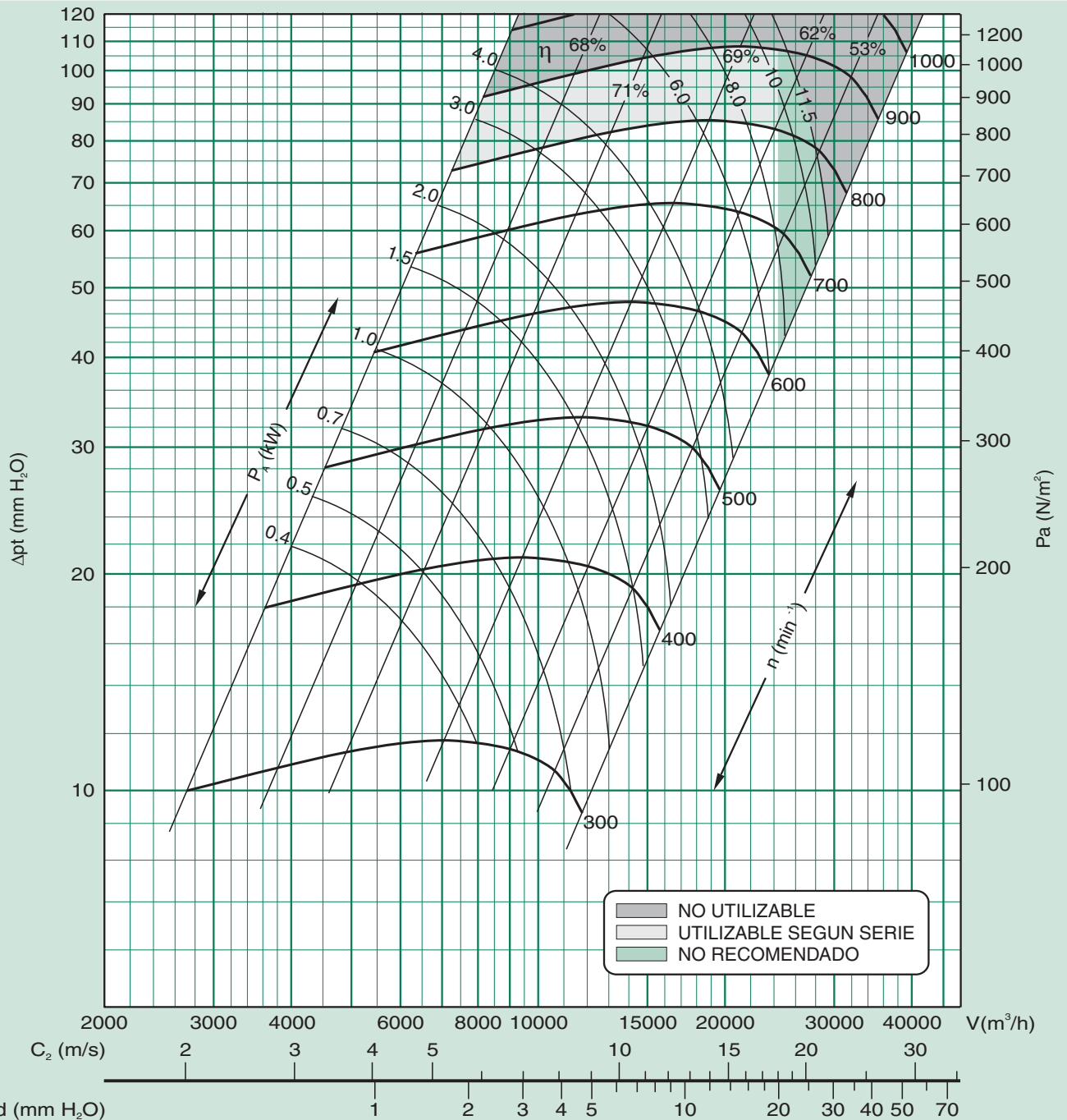

Serie

SR

Solamente en orientaciones

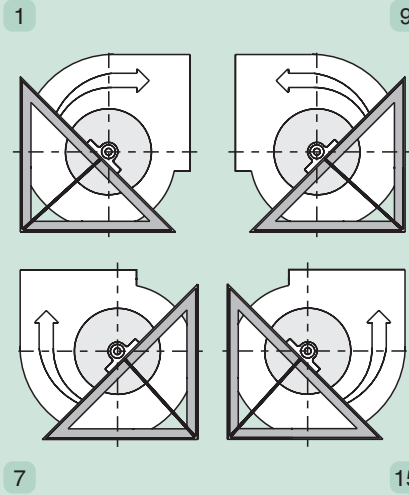
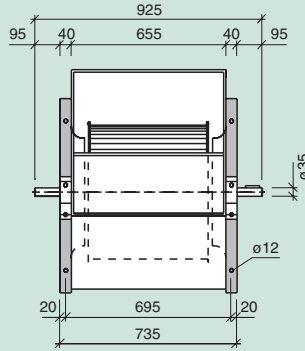
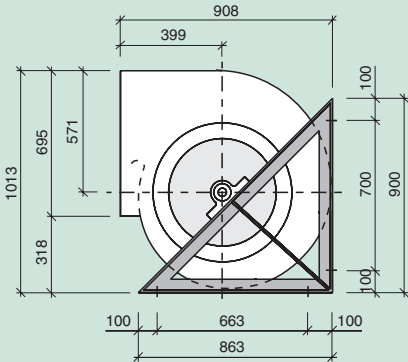

Serie

R

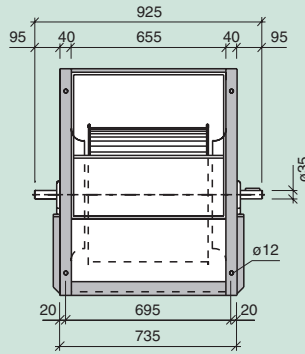
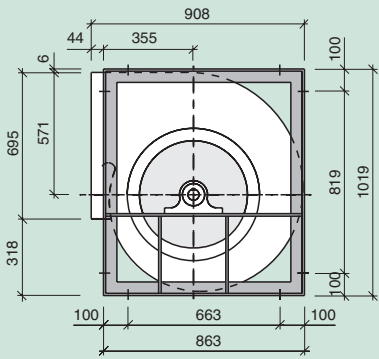

Serie

T2R

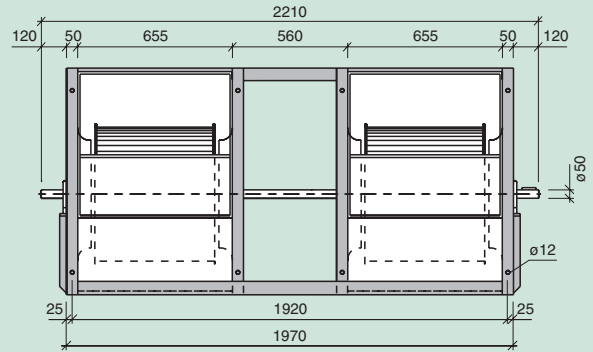
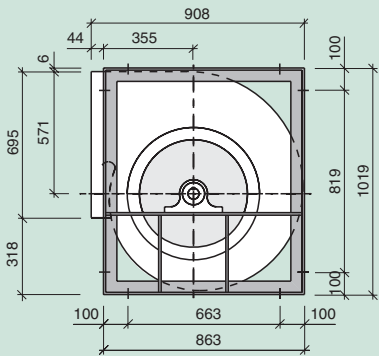

Serie - Series - Serie			SR	R			T2R	T3R
Límite de empleo. Operational limit. Limite d'emploi.	n max. motor max.	rpm kW	700 8	900 11.5			850 20	800 23
Velocidad tangencial. Tip speed. Vitesse tangentielle.	u	m/s	n (min ⁻¹) x 0.0314					
Momento de inercia. Moment of inertia. Moment d'inertie.	PD ² /4	Kg m ²	1.60	1.60			3.19	4.79
Peso del ventilador. Fan weight. Poids du ventilateur.		Kg	83	94			215	345
Coefficientes de corrección. Correction factors. Coefficients de correction.	V P _A n	m ³ /h kW min ⁻¹	x 1 x 1 x 1	x 1 x 1 x 1			x 2 x 2.15 x 1.05	x 3 x 3.25 x 1.08

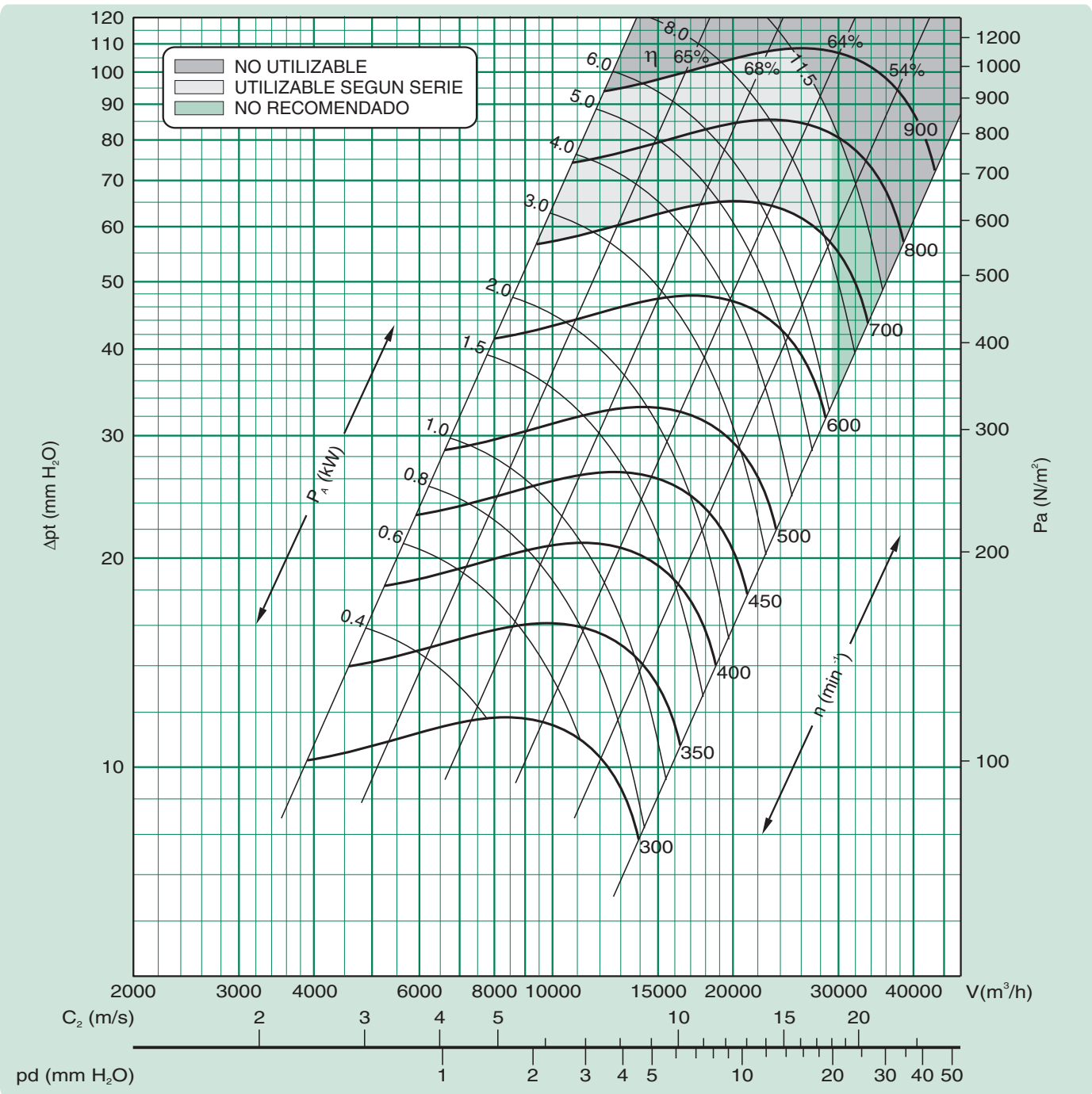

Serie

SR

Solamente en orientaciones

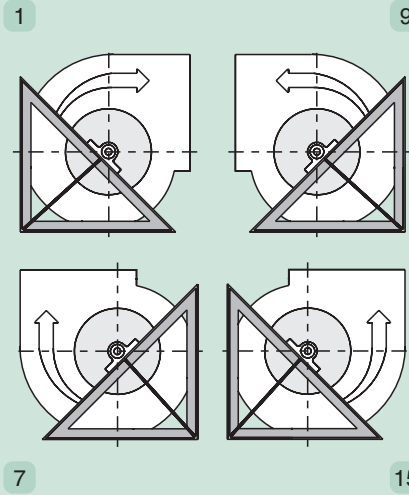
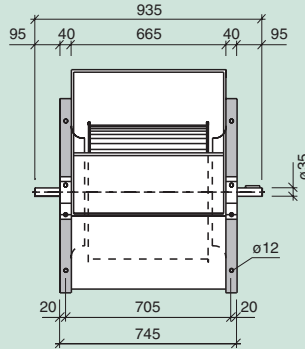
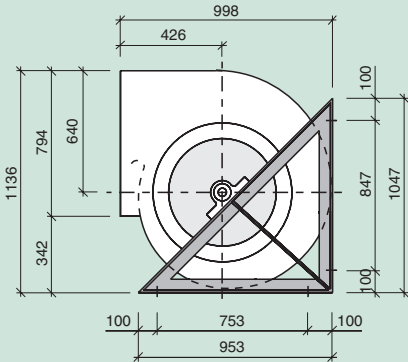

Serie

R

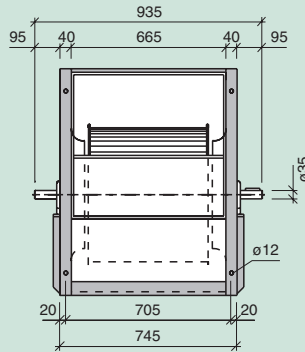
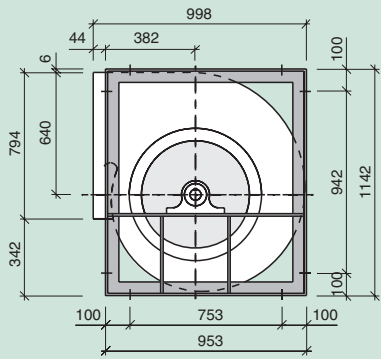

Serie

T2R

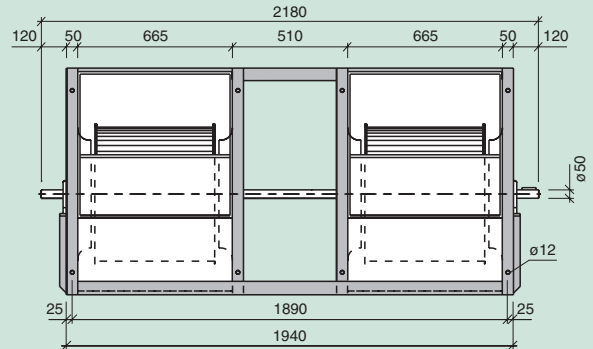
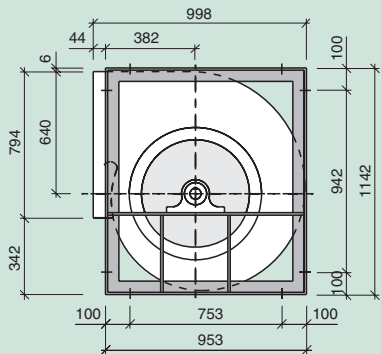

Serie - Series - Serie			SR	R		T2R	T3R
Límite de empleo. Operational limit. Limite d'emploi.	n max. motor max.	rpm kW	550 9	700 11		650 23	600 26
Velocidad tangencial. Tip speed. Vitesse tangentielle.	u	m/s	n (min ⁻¹) x 0.0351				
Momento de inercia. Moment of inertia. Moment d'inertie.	PD ² /4	Kg m ²	2.28	2.28		4.56	6.84
Peso del ventilador. Fan weight. Poids du ventilateur.		Kg	88	100		235	384
Coefficientes de corrección. Correction factors. Coefficients de correction.	V P _A n	m ³ /h kW min ⁻¹	x 1 x 1 x 1	x 1 x 1 x 1		x 2 x 2.15 x 1.05	x 3 x 3.25 x 1.08

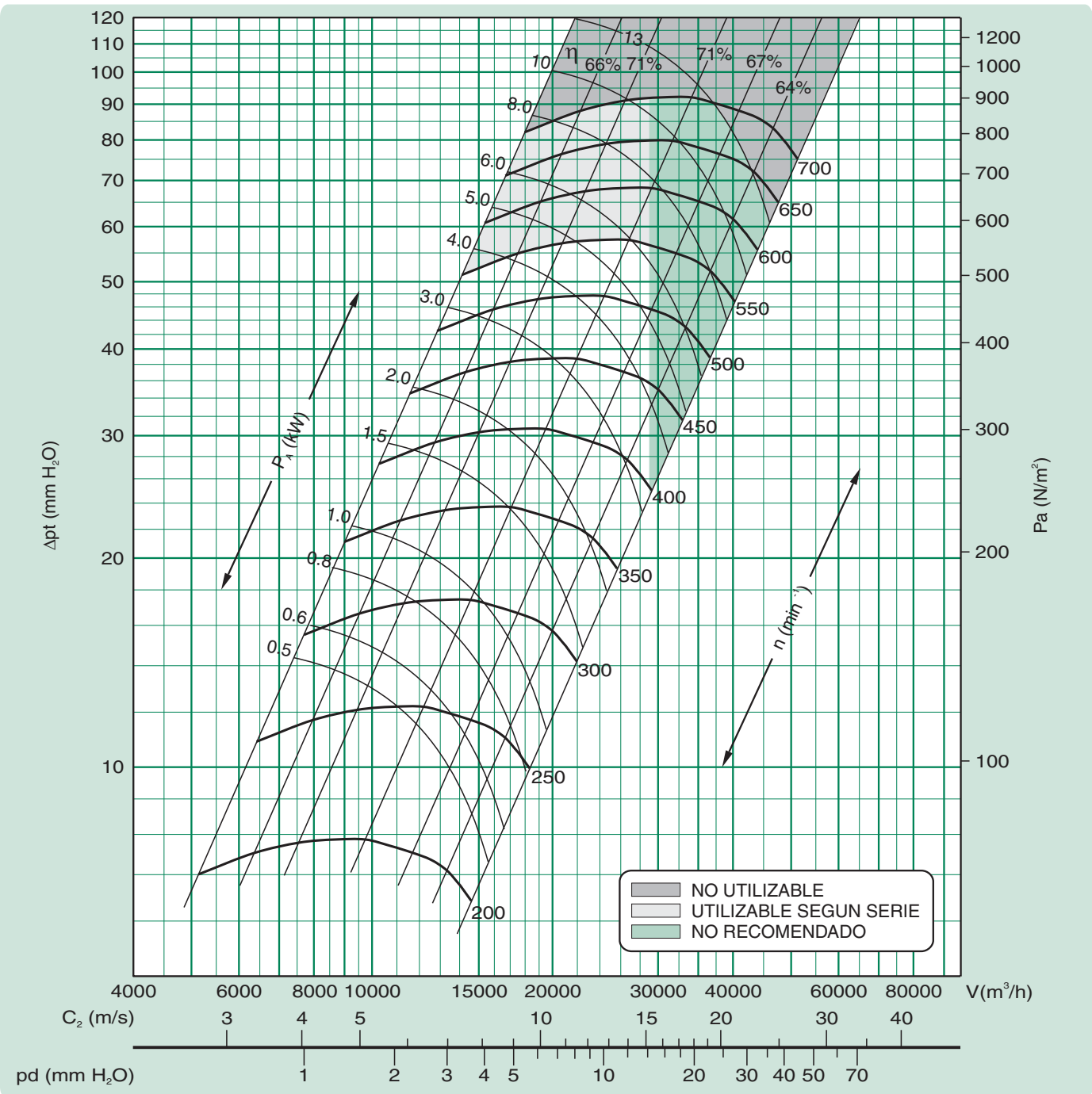

Serie

SR

Solamente en orientaciones

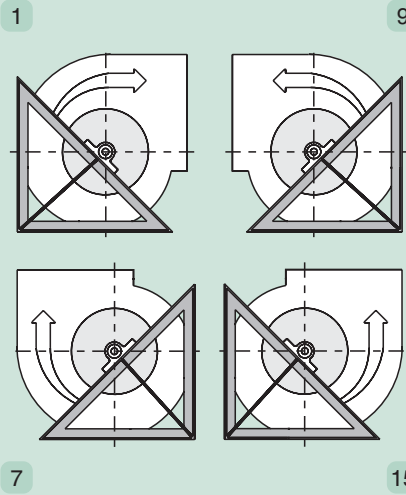
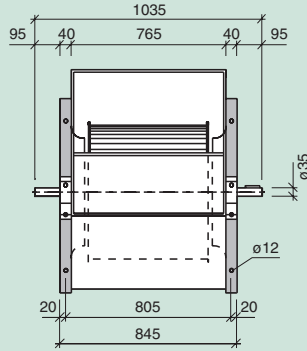
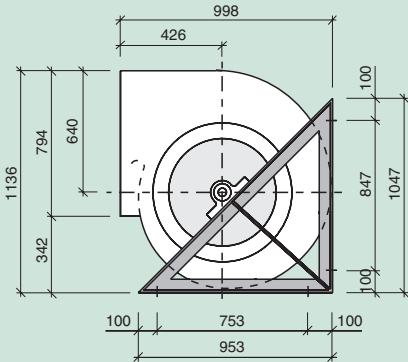

Serie

R

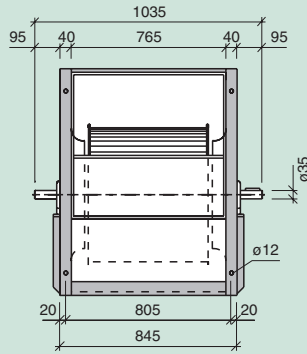
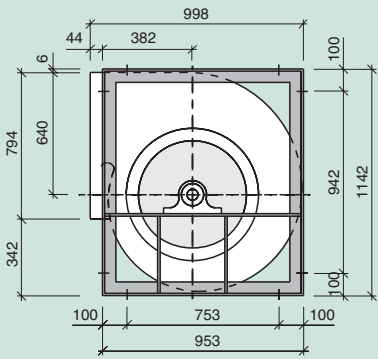

Serie

T2R

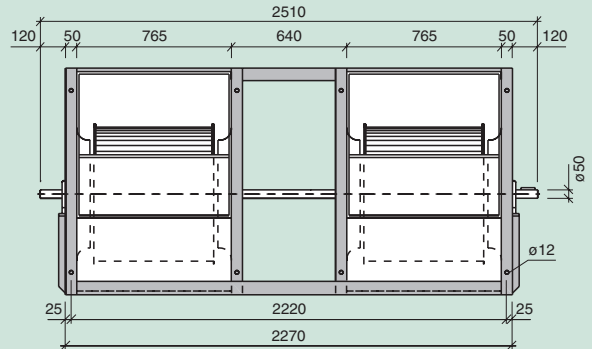
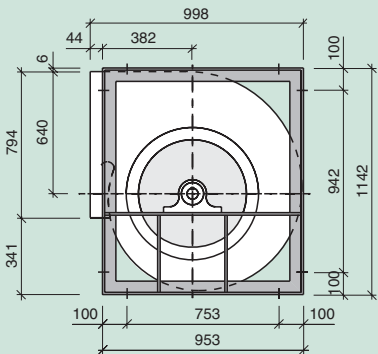

Serie - Series - Serie			SR	R			T2R	T3R
Límite de empleo. Operational limit. Limite d'emploi.	n max. motor max.	rpm kW	550 9	700 13			650 23	600 26
Velocidad tangencial. Tip speed. Vitesse tangentielle.	u	m/s	n (min ⁻¹) x 0.0351					
Momento de inercia. Moment of inertia. Moment d'inertie.	PD ² /4	Kg m ²	2.49	2.49			4.98	7.46
Peso del ventilador. Fan weight. Poids du ventilateur.		Kg	100	113			260	425
Coefficientes de corrección. Correction factors. Coefficients de correction.	V P _A n	m ³ /h kW min ⁻¹	x 1 x 1 x 1	x 1 x 1 x 1			x 2 x 2.15 x 1.05	x 3 x 3.25 x 1.08

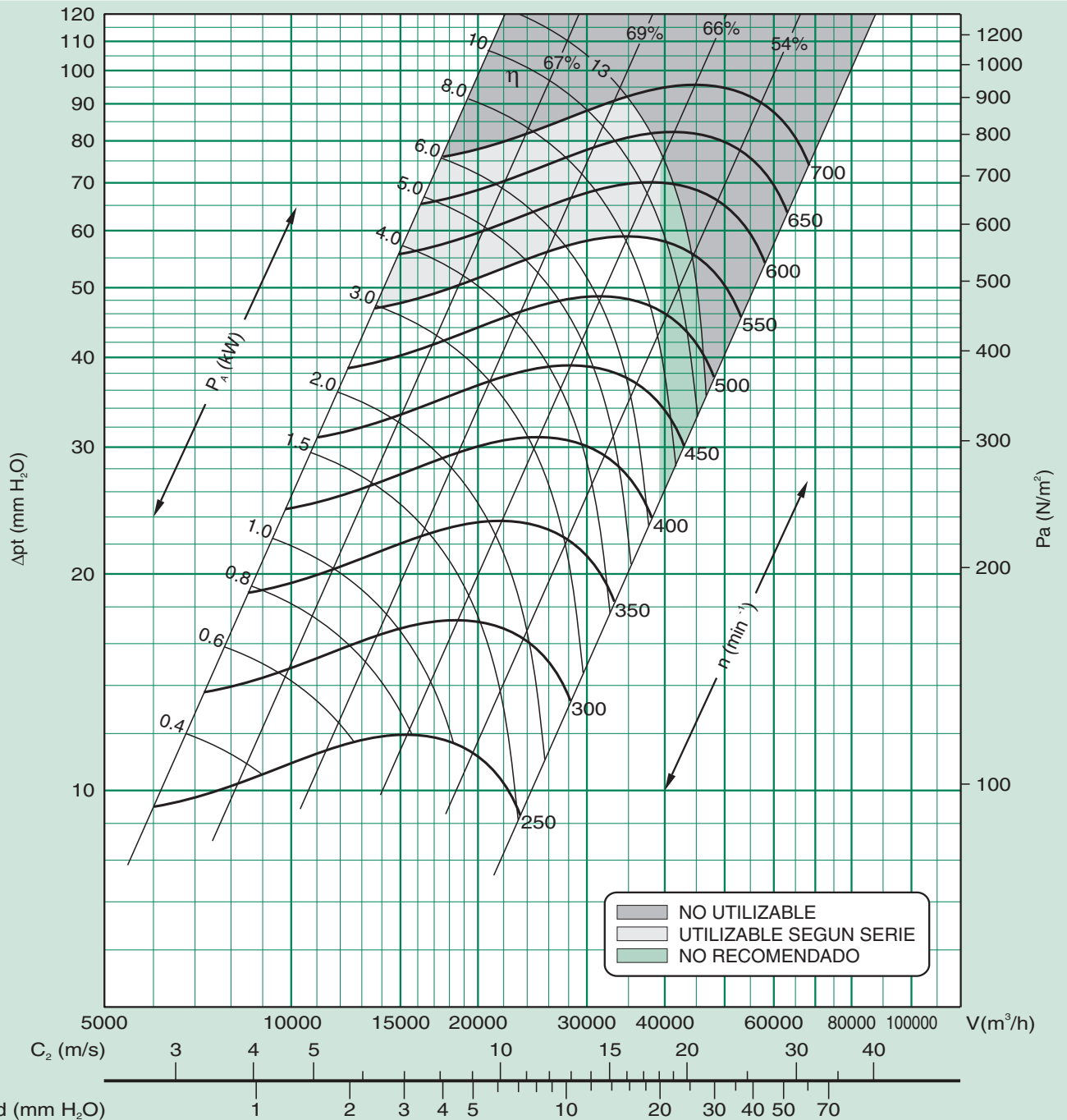

Serie

SR

Solamente en orientaciones

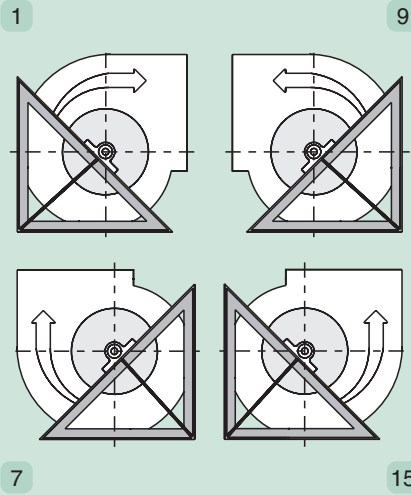
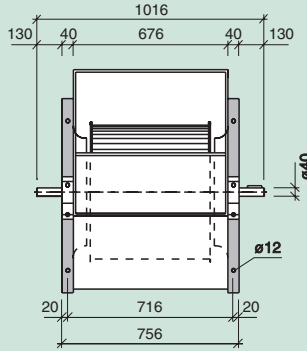
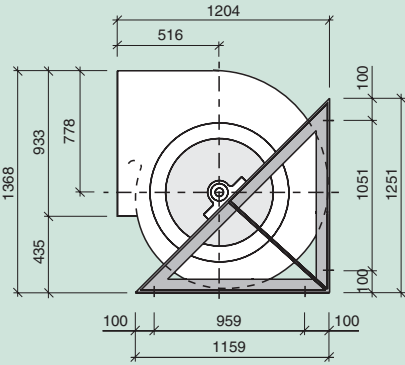

Serie

R

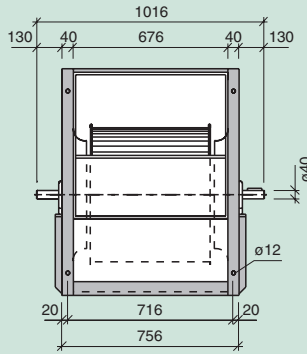
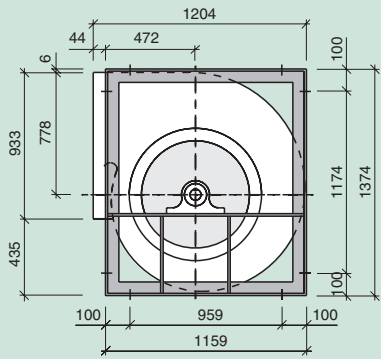

Serie

T2R

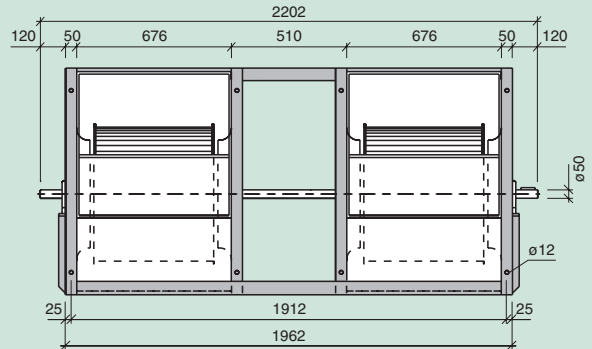
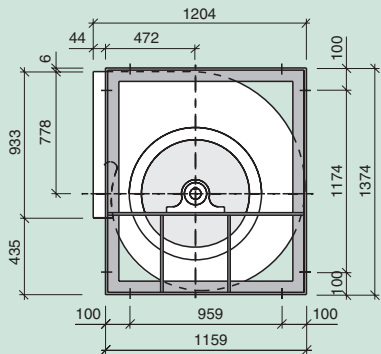

Serie - Series - Serie			SR	R		T2R	T3R
Límite de empleo. Operational limit. Limite d'emploi.	n max. motor max.	rpm kW	550 11	600 15		600 28	550 32
Velocidad tangencial. Tip speed. Vitesse tangentielle.	u	m/s	n (min ⁻¹) x 0.0419				
Momento de inercia. Moment of inertia. Moment d'inertie.	PD ² /4	Kg m ²	4.41	4.41		8.82	13.23
Peso del ventilador. Fan weight. Poids du ventilateur.		Kg	95	113		275	450
Coefficientes de corrección. Correction factors. Coefficients de correction.	V P _A n	m ³ /h kW min ⁻¹	x 1 x 1 x 1	x 1 x 1 x 1		x 2 x 2.15 x 1.05	x 3 x 3.25 x 1.08

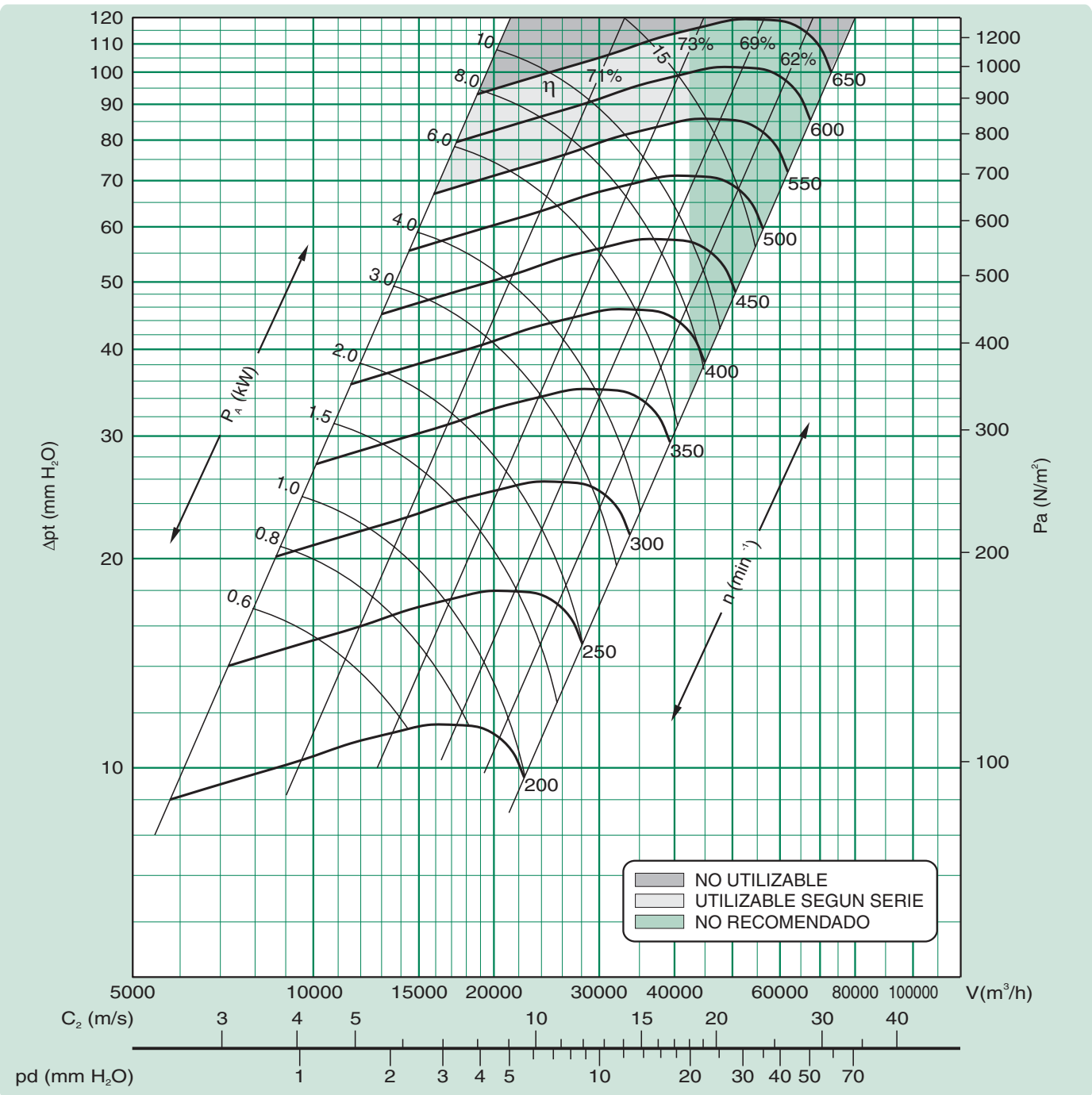

Serie - Series - Serie			SR	R		T2R	T3R
Límite de empleo. Operational limit. Limite d'emploi.	n max. motor max.	rpm kW	450 11	600 15		550 28	500 32
Velocidad tangencial. Tip speed. Vitesse tangentielle.	u	m/s	n (min ⁻¹) x 0.0419				
Momento de inercia. Moment of inertia. Moment d'inertie.	PD ² /4	Kg m ²	4.98	4.98		9.97	14.95
Peso del ventilador. Fan weight. Poids du ventilateur.		Kg	126	145		330	540
Coefficientes de corrección. Correction factors. Coefficients de correction.	V P _A n	m ³ /h kW min ⁻¹	x 1 x 1 x 1	x 1 x 1 x 1		x 2 x 2.15 x 1.05	x 3 x 3.25 x 1.08

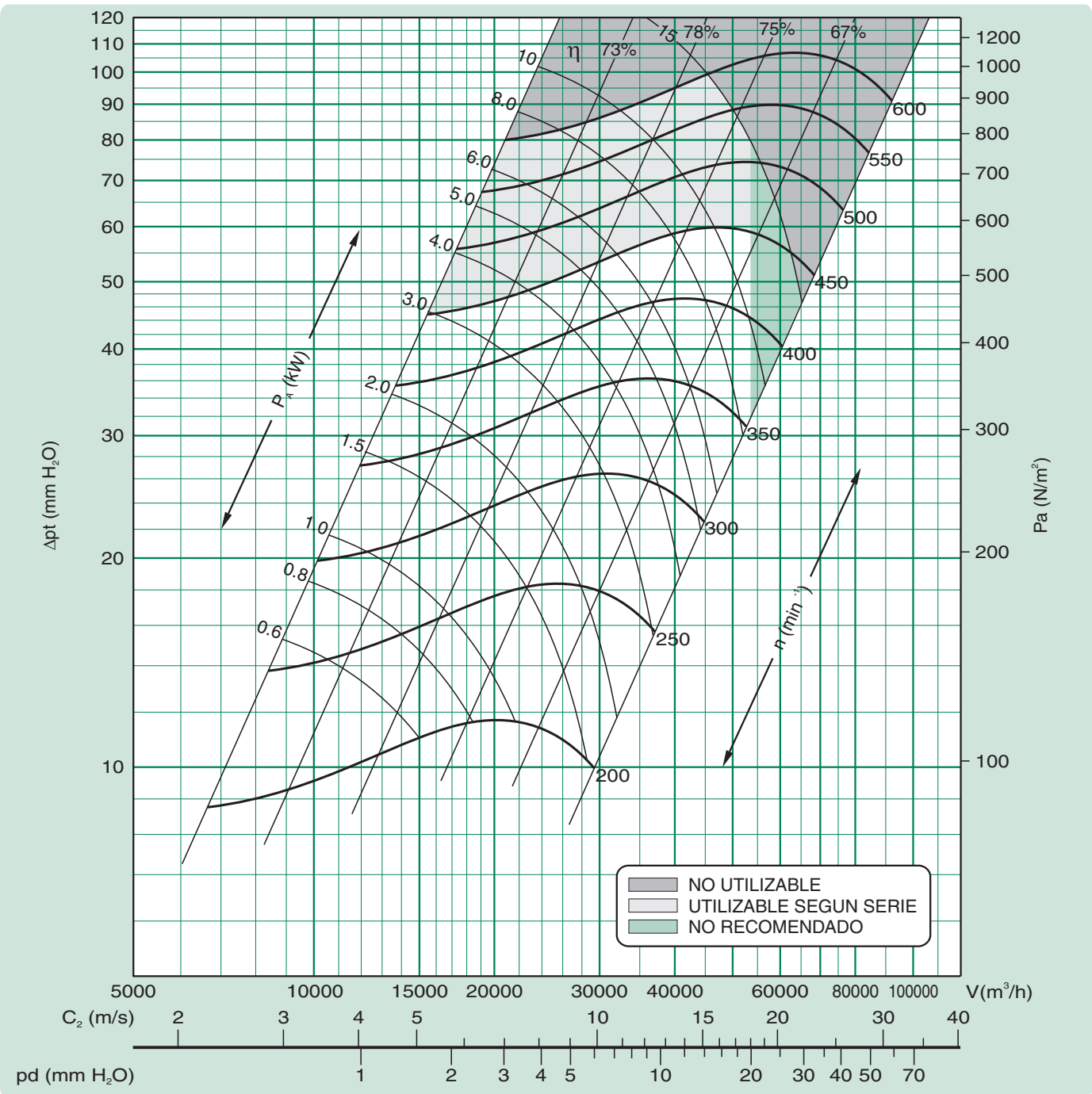

Serie

T3R

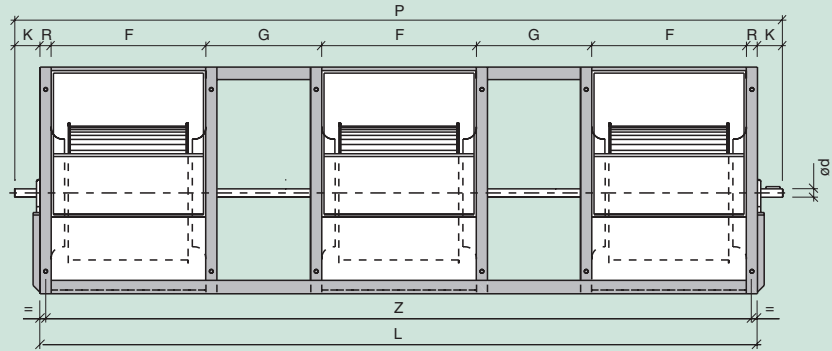
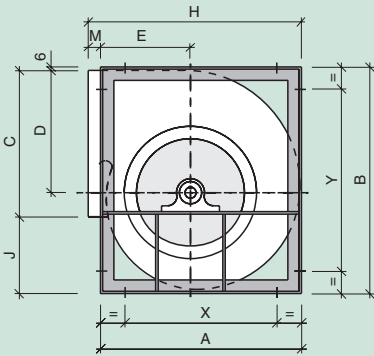

Dimensiones
Dimensions
Dimensions

TAMAÑO	A	B	C	D	E	F	G	H	K	L	M	P	R	X	Y	Z	ød	J
9 / 7	355	404	265	218	155	250	184	380	85	1166	25	1336	24	280	327	1142	30	133
9 / 9	355	404	265	218	155	298	244	380	85	1430	25	1600	24	280	327	1406	30	133
10 / 8	402	452	290	245	177	274	214	432	85	1298	30	1468	24	326	377	1274	30	156
10 / 10	402	452	290	245	177	326	263	432	85	1552	30	1722	24	326	377	1528	30	156
12 / 9	475	534	342	290	203	309	244	505	95	1473	30	1663	29	384	443	1444	35	186
12 / 12	475	534	342	290	203	386	324	505	95	1864	30	2054	29	384	443	1835	35	186
15 / 11	553	622	404	343	238	372	294	585	95	1762	30	1952	29	460	531	1733	35	212
15 / 15	553	622	404	343	238	473	384	585	95	2245	30	2435	29	460	531	2216	35	212
18 / 13	666	754	480	417	285	428	343	700	130	2040	34	2300	35	553	641	2005	40	268
18 / 18	666	754	480	417	285	556	458	700	130	2654	34	2914	35	553	641	2619	40	268
20 / 15	795	935	604	523	328	502	370	840	120	2346	44	2586	50	595	735	2296	50	325
20 / 20	795	935	604	523	328	602	480	840	120	2866	44	3106	50	595	735	2816	50	325
22 / 15	863	1019	695	571	355	514	346	908	120	2334	44	2574	50	663	819	2284	50	318
22 / 22	863	1019	695	571	355	655	560	908	120	3185	44	3425	50	663	819	3135	50	318
25 / 20	953	1142	794	640	382	665	510	998	120	3115	44	3355	50	753	942	3065	50	342
25 / 25	953	1142	794	640	382	765	640	998	120	3675	44	3915	50	753	942	3625	50	342
30 / 20	1159	1374	933	778	472	676	510	1204	120	3148	44	3388	50	959	1174	3098	50	435
30 / 28	1159	1374	933	778	472	890	720	1204	120	4210	44	4450	50	959	1174	4160	50	435