

HEAT RECOVERY UNITS WITH COOLING CIRCUIT
RCF SERIES

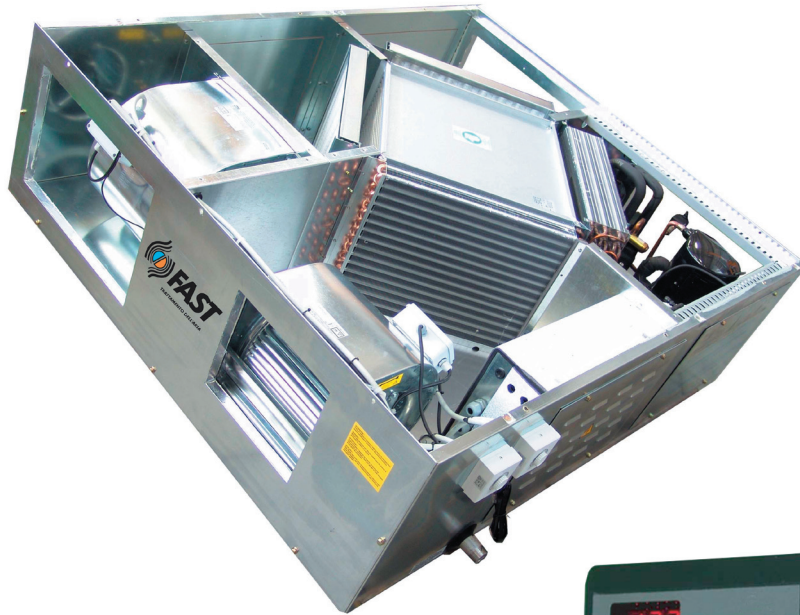

0208-6180549-rev.02



CONTROLS MANUAL



Index

Declaration of conformity	4
Introduction	5
Main characteristics	6
Installation of remote panel	6
Wiring of remote panel	7
User interface	7
Menù levels	9
Components	10
Functions	11
Diagnostics	13
Parameters setting	16
Parameters	17
Technical characteristics	24
Use of the control device	25
Responsibilities and residual risk	25

DECLARATION OF CONFORMITY:

We declare under our own responsibility that the above equipment described as follows:

1. We declare under our own responsibility that the above equipment described as follows:
Harmonized standards:
 - EN 378: Refrigerating system and heat pumps - Safety and environmental requirements;
 - EN 12735: Copper and copper alloys - Seamless, round copper tubes for air conditioning and refrigeration.
2. designed, manufactured and commercialized in compliance with the following EEC Directive:
 - PED safety 97/23/CE
 - Machinery safety 98/37/CE
 - Low voltage equipment 73/23/CEE and successive modifications.
 - Electromagnetic compatibility (EMC) 89/336/CEE and successive modifications.

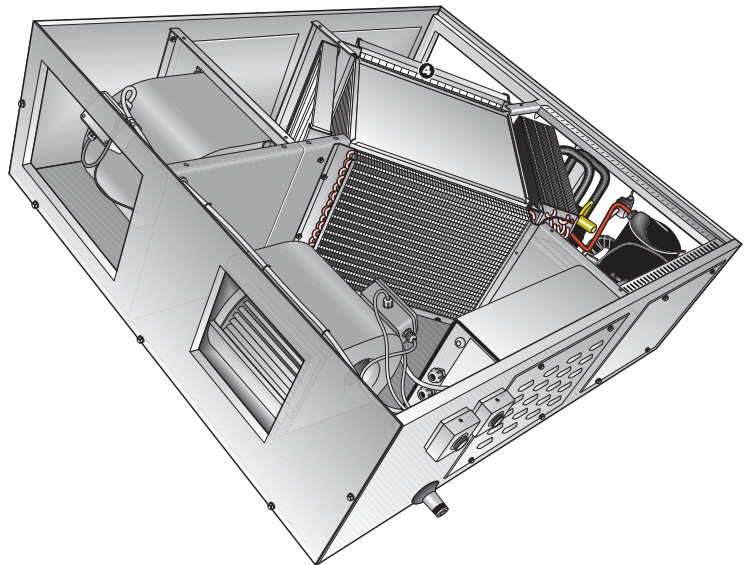

Montagnana, 04/07/2005

Managing director

Paolo Gasparini



Introduction



The control installed on the RCF unit is a compact device usually provided to control air conditioning units.

Carefully and thoroughly read all the information referred to in this manual. Pay particular attention to the norms accompanied by the indication "DANGER" or "ATTENTION" since, if not observed, may cause damage to the unit or to people.

- If any malfunctions are found out, which are not included in this manual, please contact the local After-Sales Service immediately.
- FAST S.p.A. declines all liability for any damage caused by the improper use of the machine or the partial or superficial reading of the information contained in this manual.
- Installation and maintenance must be performed by qualified and experienced personnel, having the requirements that are foreseen by law 46/90 and/or the DL 380/2001 for the electrical/electronic and air-conditioning installation, with consequent registration at the local CHAMBER OF COMMERCE, if this is not so, FAST S.p.A. declines all responsibility regarding the safety of the product.

THE MANUFACTURER DECLINES ALL LIABILITY FOR DAMAGE TO THINGS OR INJURY TO PERSONS AND ANIMALS CAUSED BY THE FAILURE TO OBSERVE THE INSTRUCTIONS AND STANDARDS IN THIS MANUAL.

Although suitable risk analysis have been performed during the design of the RCF unit, PAY ATTENTION to the pictograms on the machine which help understand the manual better, rapidly catching the attention of the reader concerning the risks which can not be avoided or sufficiently limited through the use of technical protection means and measures.

GENERAL HAZARD SIGNAL
Carefully adhere to all the indications



next to the icon. Failure to comply with the instructions may generate hazardous situations with possible damage to the health of the operator and user in general.

DANGEROUS ELECTRICAL VOLTAGE SIGNAL



Carefully adhere to all the indications next to the icon. This signal indicates components of the unit or, in this manual, specifies actions that could generate electrically-related risks.

GENERAL PROHIBITION SIGNAL

Carefully adhere to all the indications next to the icon that limit actions in order to guarantee better operator safety.



MAIN WARRANTY CONDITIONS

- The warranty does not cover payment for damages caused by the incorrect installation of the unit by the installer.
- The warranty does not cover payment for damages caused by the improper use of the unit by the user.
- The manufacturer is not responsible for accidents to the installer or user that are due to the improper use and incorrect installation of the unit.

The warranty is not valid when:

- the maintenance and repairs have been performed by unauthorised persons or companies;
- the unit has been previously repaired or modified with spare parts that are not original;
- the unit has not undergone suitable maintenance;
- the instructions described in the present manual have not been followed correctly;
- unauthorised modifications have been made.

Note:

The Manufacturer reserves the right at all times to make any modification

for the improvement of its product and is not obliged to add these modifications to machines of previous manufacture, which have already been delivered or are being built. The warranty conditions are any subject to the general sales conditions at the moment the contract is finalised.

Main characteristics

Generalities

The RCF units are provided with an electrical panel including the power supply section and the controls (the 3-ways valve for the hot water coil, if required, and the actuators are included) to manage all the functions of the cooling circuit. The controls include: NTC temperature probe on the exhaust air flow, NTC temperature probe for the fresh air flow, differential pressure switch for the fresh air filter. When the free-cooling accessory is required, the dampers and the actuators are provided for. A remote control panel is also included for the remote manage-

ment of the unit (max. distance 150m, wiring cable not included).

The main functions of the control panel are:

- room temperature control, based on the temperature of the exhaust air;
- management of the de-frosting processes;
- remote ON-OFF;
- Summer/Winter switch;
- electric heating coil control (if required);
- water heating coil control (if required);
- User interface with two different levels of accessibility with password (inside the electrical panel);

- remote panel (max. distance 150m) to be connected directly to the unit (wiring cable not included).

Troubleshooting

The controls check and mark the following possible failures:

- temperature probe failure
- cooling circuit high and low pressures
- compressor thermal protection
- fan thermal protection.

Installation of remote panel

The connecting terminal of the remote control and the connecting terminal on the electrical panel has to be connected by means of shielded electrical cables with min. 0.5 mm² section and max. 150m length (cables non included).

Please, refer to the paragraph "Wiring of remote panel" for the connecting procedure.

To access the keyboard on the remote panel remove the front panel (with a screwdriver or similar tool) as shown in fig. 01.

The cables must pass through the central hole in the rear section (fig. 01).

The keyboard is designed to be wall-mounted. After removing the front part,

drill four 4 mm diameter holes in the wall at the specified distance. Fix the black rear part to the wall with four screws. After carrying out the necessary connections, close the front section of the keyboard by simply pushing it in place.

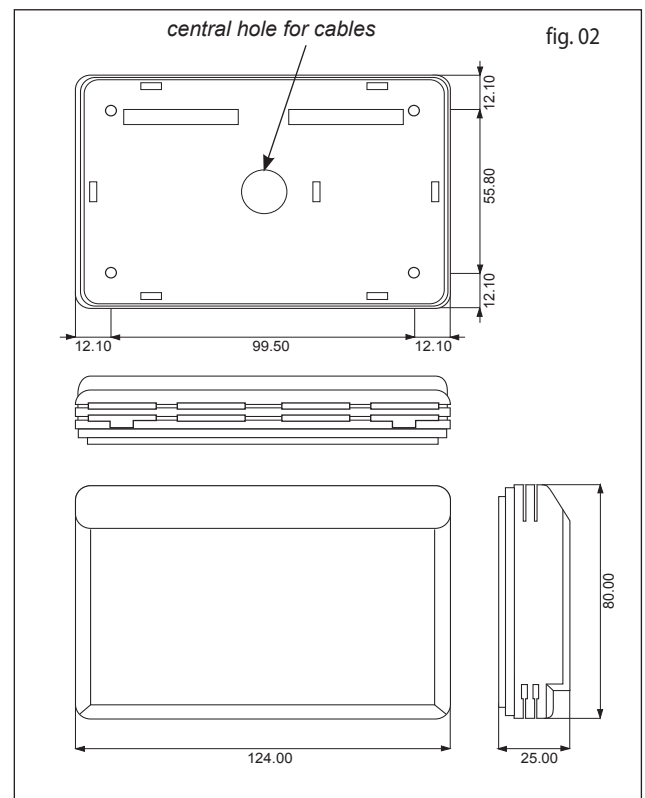
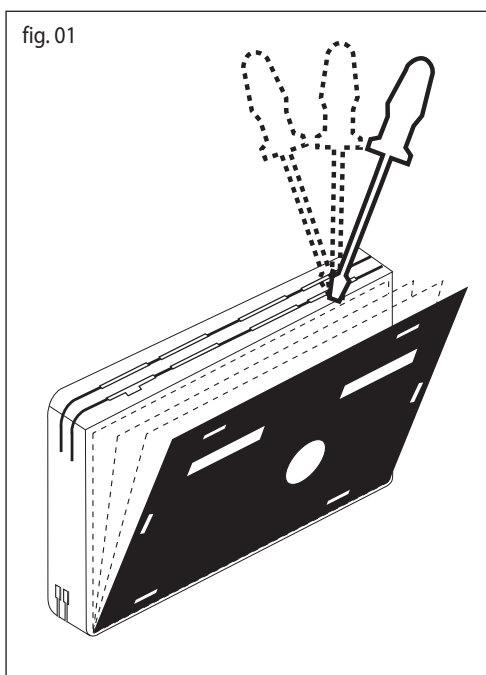

Wiring of remote panel

During the connection procedure between the electrical panel and the remote control respect the following rules:

- do not apply to the analogue and digital outputs powers higher than the ones declared in this manual;
- make the connections respecting the wiring diagrams in this manual;
- keep the power supply cables divided from the control cables to prevent from interferences.

Analogue inputs

There are 4 analogue inputs:

- 3 NTC temperature probes
- 1 input which may be configured for an NTC probe or 4...20mA signal.

The inputs are identified from here on as AI1...AI4.

Digital inputs

There are 5 voltage-free digital inputs identified from here on as ID1...ID15.

AI1, AI2 and AI4 may also be added to these if they are configured as digital inputs (with parameters Pa H05, Pa H06, Pa H08).

8 digital inputs are therefore available.

Wiring of remote panel

Important! Never connect the keyboard when the instrument is on. Avoid short-circuiting on the cables when the instrument is on: this may damage the instrument.

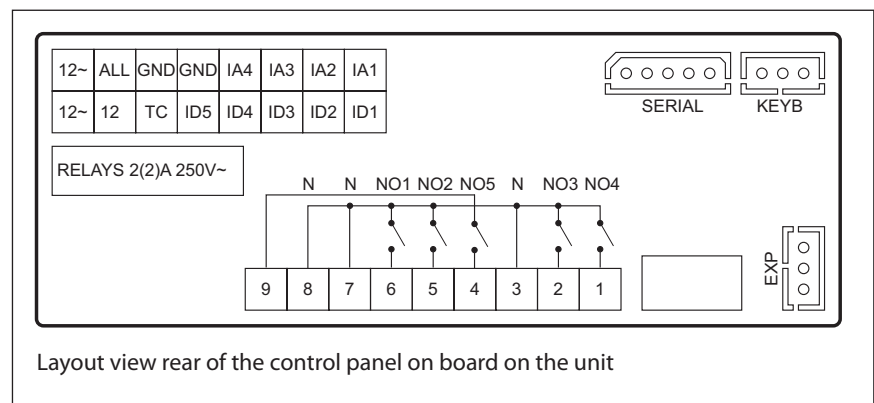
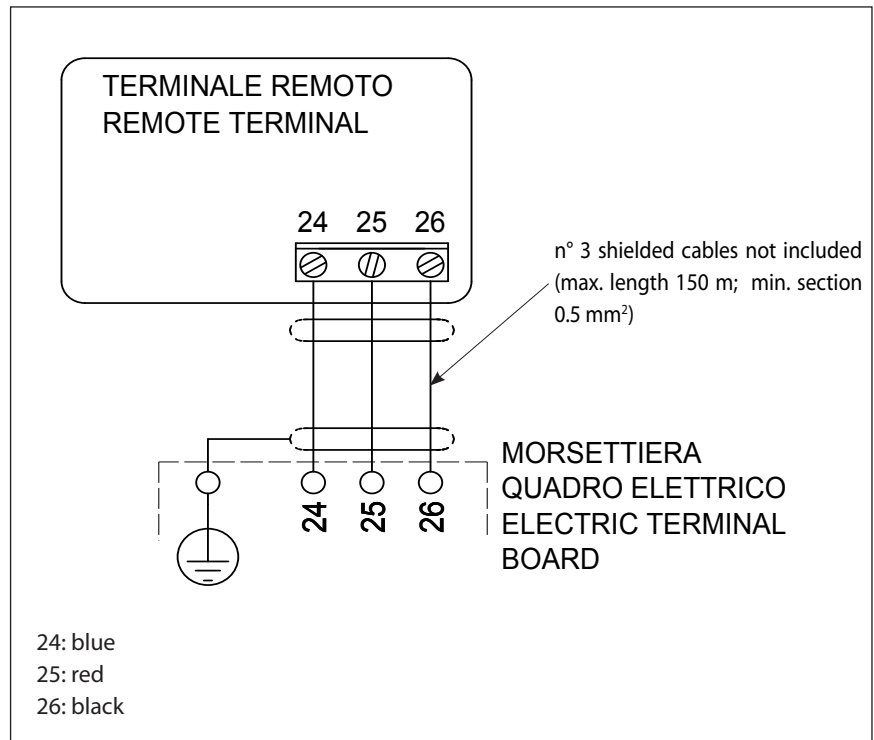

User interface

User interface

The user interface allows for the control of all the unit operations:

- operating setting mode
- components checks and controls
- alarms management

Displays

The device shows all the informations and the alarms by means of a display and led signals present on the front panel.



Buttons

MODE

Selects the operating mode:

If the Heating mode is enabled, each time the button is pressed the following sequence occurs:

stand-by -> cooling -> heating -> stand-by

If the Heating mode is not enabled:

stand-by -> cooling -> stand-by

SET

Resets alarms and modifies the set point.

Press once to reset all inactive alarms that can be reset manually.

If you hold the button down for 2 seconds, the unit displays the set point of the set mode.

MODE

SET

If you press both buttons at the same time and then release them within 2 seconds, you go down one level in the display menu.

If you press both buttons for more than 2 seconds, you move one level up.

If the last level of a menu is displayed, press the button and release it within two seconds to go up one level.



In menu operating mode it shows the previous label or increases the shown value (depending on the context).



In menu operating mode it shows the following label or decreases the shown value (depending on the context)

Display

In Normal mode, the unit displays:

- the control temperature, in tenths of degrees Celsius with a decimal point or in Fahrenheit with no decimal point.

- the alarm code, if at least one is active. If several alarms are active, the unit displays the first alarm listed in the Alarm Table.

- If temperature control is not based on the analogue inputs and is linked to the status of a digital input (AI1 or AI2 configured as digital inputs), the "On" or "Off" label will be displayed, depending on whether temperature control is active or not.

- In Menu mode, displaying varies according to the position. Special labels and codes are used to help users identify the function that has been set.

Decimal point: when displaying the operating hours, it indicates that the value must be multiplied x 100.

In normal operation, the display shows the temperature given by the NTC probe on the exhaust flow (room temperature). To display the setting keep the button "set" pushed for nearly 3 seconds.

Leds

LED 1 compressor 1



- ON if compressor 1 is active
- OFF if compressor 1 is inactive

- BLINK if safety timing is in progress

Defrost LED



- ON if defrosting is active
- OFF if defrosting is disabled or has been completed

- BLINK if timing is in progress (defrosting time)

Electric heater LED



- ON if the internal anti-freeze electric heater are on

- OFF if the internal anti-freeze electric heater are off

Heating LED



- ON if the unit is in Heating mode.

Cooling LED



- ON if the controller is in Cooling mode

If neither the HEAT LED or the COOL LED are lit, the controller is in STANDBY mode.

On board control panel

The control panel on board of the unit performs the same functions and displays the same parameters of the remote panel.

The setting procedure are the same described for the remote panel.

The "Upwards arrow" button operates also as "Mode" button, while the "Downwards arrow" button operates also as "Set" button.



Parameter programming – Menu levels

The setting parameters of the control device may be modified through the control panel keyboard. The various parameters are organized in groups accessible when pressing the "mode" and "on-off" buttons at the same time. Each menu level is identified by a mnemonic code which appears on the display. For more info please refer to the following page.

Menù levels

Levels hierarchy

The level 0 always shows the exhaust air temperature or an alarm, if active.

To move through the levels and the labels use the arrow buttons.

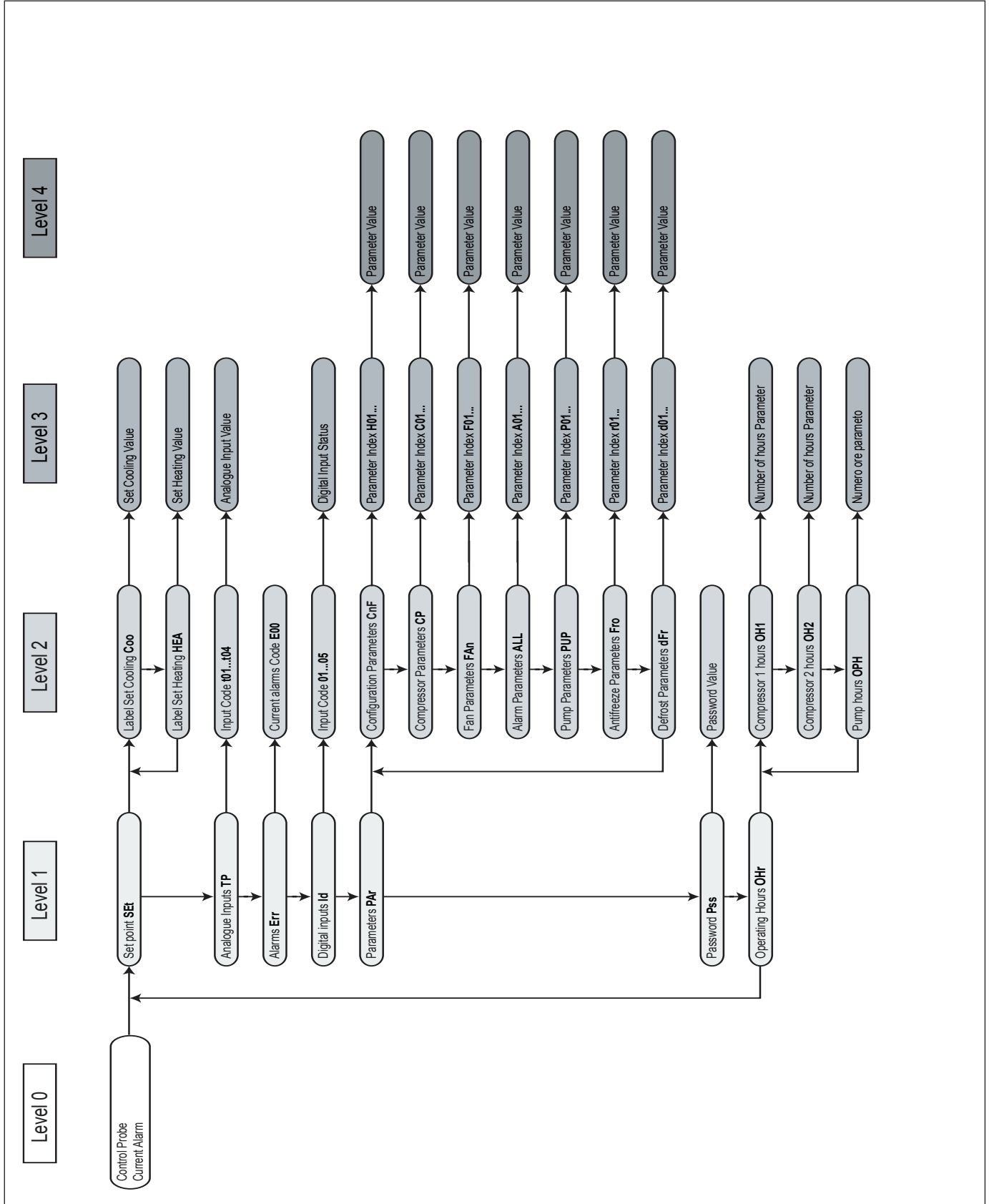

Components

Compressor

The compressor is controlled by the relays of the control panel on board of the unit. Compressors are turned on and off according to the temperatures detected and the temperature control functions that have been set.

Compressor configuration

The compressor must be connected to output NO1.

Compressor timing

Compressor start-up and shut-down operations must comply with the safety times set by the user using the parameters described below. A safety period must elapse between shut-down and start-up of the same compressor (compressor on...off safety time) controlled by parameter Pa C01; This parameter also applies to when the device is started up.

A safety period must elapse between one start-up and the next (compressor on...on safety time) controlled by parameter Pa C02.

Reversing valve

The reversing valve refers to the "heat pump" operating mode. The reversing valve is off if the instrument is OFF and on standby.

Fans

The fans are cabled on a single relay output NO2 (see wiring diagrams). The fans are configured to operate in continuous mode.

Electric heating coil (MBX) and Water heating coil (MBC)

Connect the electric heating coil or the water heating coil to the NO4 relay output (see wiring diagrams).

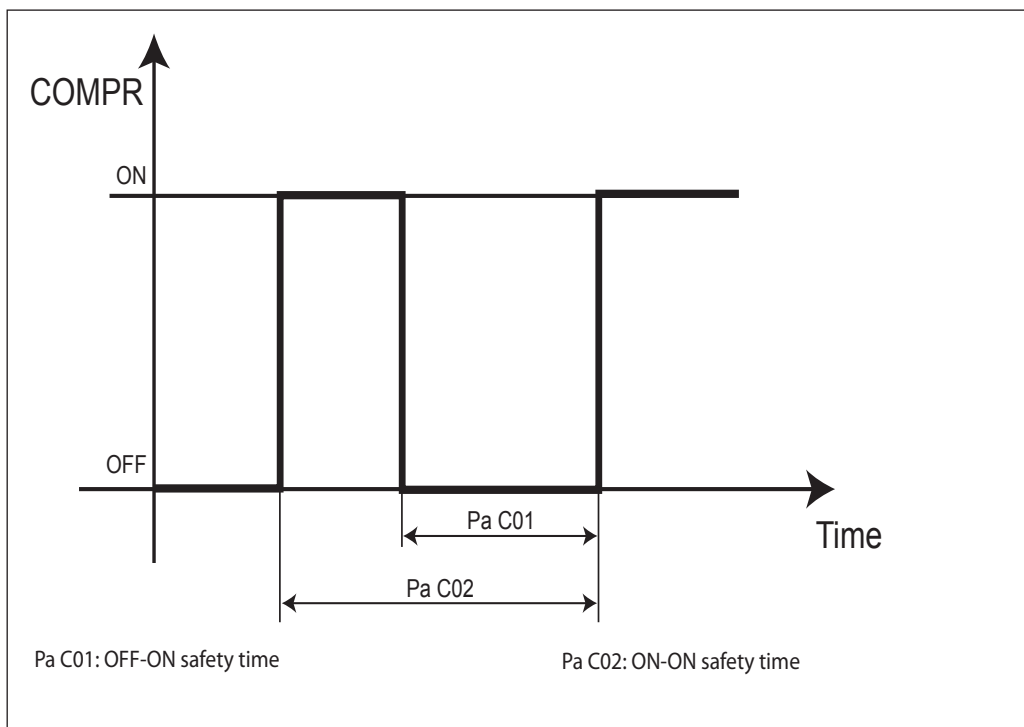

Functions

The operating parameters are set in the factory to control the unit depending on the signals given by the temperature and pressure probes.

There are 3 operating modes:

- Cooling
- Heating
- Stand-by

Cooling: this is the “summer” operating mode; in this mode the unit is configured to generate cold air.

Heating: this is the “winter” operating mode; in this mode the unit is configured to generate hot air.

Stand-by: in this mode the machine does not perform temperature control functions and all the alarms remain active.

Setting set points

Activation or de-activation of the loads varies dynamically according to the temperature control functions set, the temperature/pressure values measured by the probes and the set points.

Two set points are defined:

Cooling set point: this is the reference set point when the unit is in Cooling mode

Heating set point: this is the reference set point when the device is in Heating mode

Set points can be changed from the keyboard by accessing submenu “SET” (see menu layout) or by pressing the set button for 2 seconds.

Set points can be assigned values that fall within a range determined by parameters Pa H02 – Pa H01 (Heating) and Pa H04 – H03 (Cooling)

ON OFF from digital input

Digital inputs ID3, ID4, ID5 and AI4 (analogue inputs) can be configured to give an ON-OFF command. If this type of input is activated, the instrument will turn off all loads and “E00” appears on the display..

Electric heating coil (MBXxx) or water heating coil (MBCxx) (accessories) (fig. 1)

In heating mode, the electric heaters or the coils are activated when $AI1 < (SET \text{ Heating}$

- Pa r14). If the heat pump is off because the outdoor temperature is too low, the electric heaters are directly controlled by the heating set point.

Freecooling and freeheating (accessory FCExx)

Freecooling and freeheating are used to cool or heat the internal environment using outdoor air. The external air enters the environment through a damper that mixes it with the recirculated air from inside. Damper control is ON/OFF.

FREECOOLING

The freecooling set point is calculated by subtracting the value equal to parameter F26 (freecooling offset in cooling mode) from the cooling set point. If the freecooling set point were to coincide with the cooling set point, the damper would close as the same time as the compressors are switched off and any energy saved by using colder outdoor air would be lost.

This is valid if

- the outdoor temperature is lower than the cooling set point
- the inside temperature is higher than the outdoor temperature. If the inside temperature is lower than the outdoor temperature and both are lower than the cooling set point, the damper is completely open. The control hysteresis is 10°C.

FREEHEATING

The freeheating set point is calculated by adding the value equal to parameter F28 (freecooling offset in heating mode) to the heating set point. If the freeheating set point

were to coincide with the heating set point, the damper would close as the same time as the compressors are switched off and any energy saved by using warmer outdoor air would be lost.

This is valid if

- the outdoor temperature is higher than the heating set point
- the inside temperature is lower than the outdoor temperature. If the inside temperature is higher than the outdoor temperature and both are higher than the heating set point, the damper is completely open. The control hysteresis is 10°C.

Damper closed if temperature is low

Air that is too cold entering the environment affects the well-being of its occupants. For this reason, if the outdoor temperature is lower than Pa F32 (freecooling shutdown set point), the damper is forced to minimum opening (Pa F31). If the outdoor temperature is higher than Pa F32+ Pa F33, the freecooling control returns to normal.

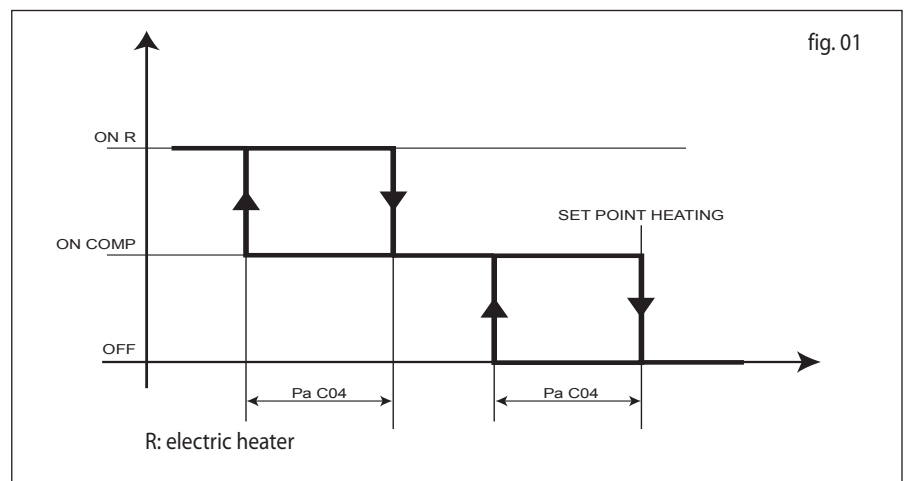

Recording operating hours

The device stores the number of operating hours for the following in the non-volatile memory:

- evaporator fan
- compressor.

Internal resolution is in minutes.

The values can be displayed by accessing the menu with the label Ohr (see menu layout). The whole value is displayed for values below 999 whereas hours/100 value along with the decimal point is displayed for values above 999. For example, 1234 hours are displayed as follows:



The hours can be reset by pressing the DOWN button for two seconds (see buttons) while the operating hours are displayed.



In the event of a power failure, the last fraction of hour recorded is set to 0 and the duration is rounded off by default.

Defrosting

The defrost function is only active in Heating mode.

This function is used to prevent the formation of ice on the surface of the external heat exchanger.

This significantly reduces the thermodynamic performance of the unit and could cause it severe damage.

Defrosting is controlled according to pressure.

Defrost start and stop commands are given on the basis of condensation probe readings and parameter settings, as described below.

Defrost mode start (fig. 01)

If the condensing pressure is lower than 3 bar (defrost starting pressure) and the compressor

is ON, the control starts the defrost countdown (1 min countdown). When 1 min passed, the control device starts the defrosting process. At this point Pa d06 (compressor valve time delay) = 30 sec., the control procedure described in fig. 01 is operated.

This delay prevents the compressor from liquid returns. During this operation the safety timings of the compressor are not considered. The defrost starting and stopping pressures are the following:

- defrost start: 3 bar
- defrost stop: 10 bar.

Defrost mode stop (fig. 02)

The defrosting process stops if:

- the condensing pressure raises up to the defrost stop pressure,
- the defrosting process doesn't stop in 5 min (max. defrosting time).

Counter mode

- The defrost time counter is interrupted when temperature/pressure rises above Pa

d02 (defrost start temperature/pressure) or the compressor is turned off.

- The counter is reset following one of these events: defrost cycle performed; power failure; change in operating mode.
- The counter is also reset when the temperature/pressure rises above Pa d04 (defrost end temperature/pressure).

Power failure

If there is a power failure, when the power is restored the control returns to the state prior to the power failure. If defrosting is in progress, the procedure is cancelled. All timing in progress is cancelled and restarted.

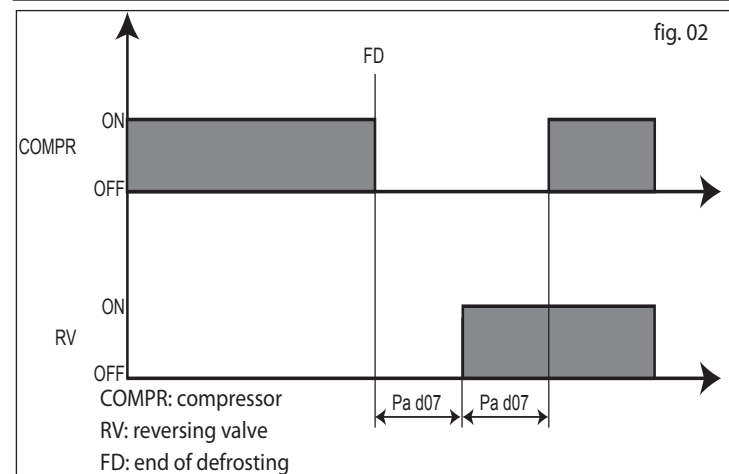
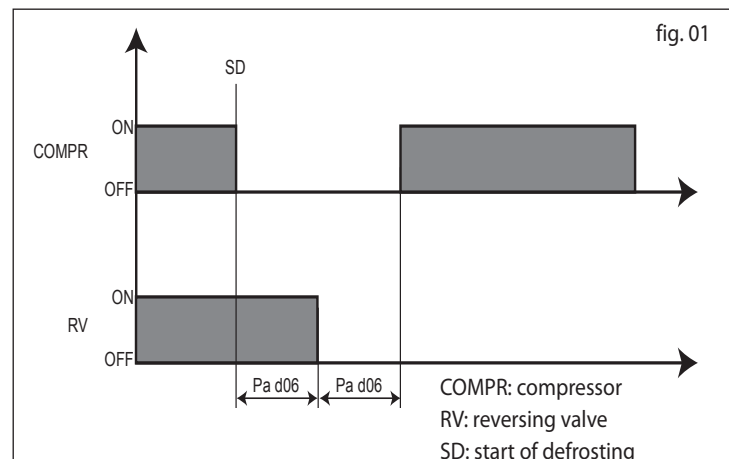

Diagnosics

The control device can perform a complete check of the unit giving a list of possible alarms. Alarms can be activated and reset using parameters Pa A01 – Pa A26

Some alarms can be de-activated for a preset interval of time that is determined by the relative parameter. The unit is also able to count the number of events for specific alarms: if the number of alarms in the last hour exceeds the threshold set for the parameter, the alarm switches from automatic to manual reset mode.

Alarms are sampled every 225 seconds.

Example: if the number of events is set to 3, the duration of the alarm must last between $2 \cdot 225$ seconds and $3 \cdot 225$ seconds for the alarm to be switched from automatic to manual reset.

If an alarm is triggered more than once within one sampling period (225 seconds), it will only be counted once.

To reset alarms configured for manual resetting, press the ON-OFF button and then release it.

Manual resetting shuts down corresponding loads and requires operator intervention (alarm reset using the ON-OFF button).

Manually reset alarms are used to signal potential problems that could damage the system.

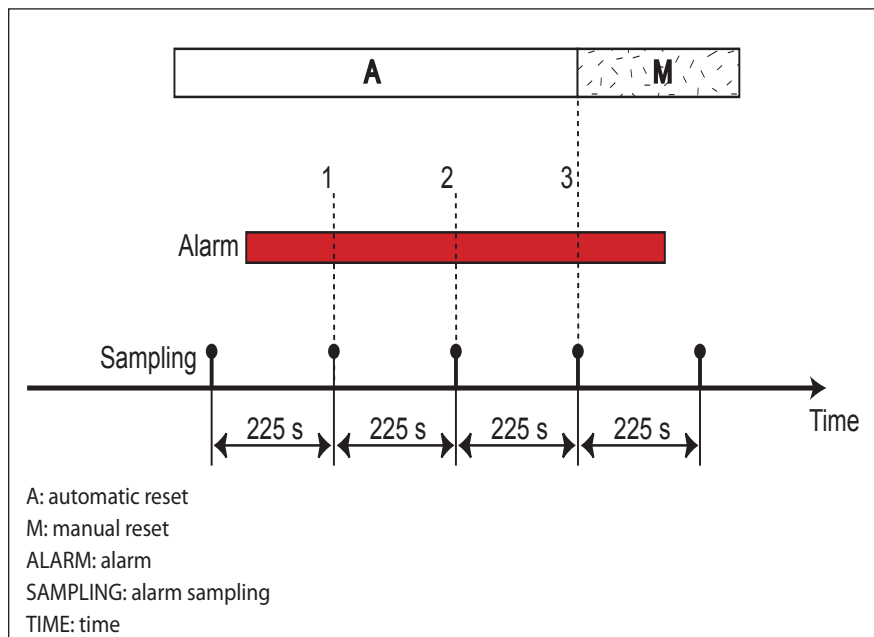

List of alarms

When an alarm is triggered, it has two effects:

- The corresponding loads are shut down

• The alarm appears on the keyboard display

The alarm message consists of an "Enn" code (where nn stands for a two digit number

that identifies the type of alarm; i.e. E00, E25, E39....).

CODE	SIGNAL	DESCRIPTION	COMPR.	FAN	ELECTRIC HEATERS	RESET
E00	Remote Off	Triggered by the digital input configured as "Remote ON-OFF" (see digital inputs)	OFF	OFF	OFF	
E01	High pressure (digital)	Triggered by the digital input ID1 (see digital inputs)	OFF	ON		Always manually reset.
E02	Low pressure (digital)	Triggered by the digital input ID2 (see digital inputs)	OFF	OFF if H22=1 ON if H22=0		Reset is carried out automatically if the number of events per hour is equal to parameter A02, otherwise it switches to manual. Not active when time Pa A01 is counted after a compressor is turned on or the 4-way valve (reversing valve) is reversed. Inactive during defrosting if Pa 24 = 0
E03	Thermal switch protection compressor 1	Triggered by the digital input configured as "Compressor 1 thermal switch" (see digital inputs)	OFF	ON		Automatically reset unless alarm events per hour reaches the value of parameter Pa A08, after which it is manually reset. Not active when Pa A07 time is counted after a compressor is turned on.
E04	Condenser fan thermal switch protection	Triggered by the digital input configured as "Fan thermal switch" (see digital inputs)	OFF	OFF		Reset is carried out automatically if the number of events per hour is equal to parameter A09, otherwise it becomes manual.
E05	Anti-freeze	Pa A18 parameter selects the alarm probe: Pa A18 = 0 AI1, Pa A18 = 1 AI2. External fans and compressors will be shut down; Active if analogue probe selected (see analogue inputs) is configured as NTC probe (Pa H06=1 or Pa H07=1); Triggered when probe AI5 detects a value below Pa A11; Goes off if the probe detects a value greater than Pa A11 + Pa A12.	OFF			Reset is carried out automatically if the number of events per hour is equal to parameter A09, otherwise it switches to manual. In Heating mode, it is not active while the Pa A10 time is counted from start-up of the unit with ON-OFF button (see keyboard) or with ON-OFF digital input (see digital inputs)
E06	Probe AI2 faulty	Triggered if probe AI1, configured as an analogue input, shorts or is cut off or probe limits are exceed (-50°C ...100°C)	OFF	OFF	OFF	

CODE	SIGNAL	DESCRIPTION	COMPR.	FAN	ELECTRIC HEATERS	RESET
E07	Probe AI3 faulty	Triggered if probe AI3, configured as an analogue input, shorts or is cut off or probe limits are exceed (-50°C ...100°C)	OFF	OFF	OFF	
E40	Probe AI3 faulty	Triggered if probe AI3, configured as an analogue input, shorts or is cut off or probe limits are exceed (-50°C ...100°C)	OFF	OFF	OFF	
E41	Worn filters	Triggered if the digital input configured as "worn filters" (see digital inputs) remains active for a period of time equal to Pa A04; Goes off if the digital input configured as "worn filters" (see digital inputs) remains inactive for a period of time equal to Pa A05. Not active when the Pa A03 time is counted after fan is turned on.	OFF	OFF ³		Reset is carried out automatically if the number of events per hour is equal to parameter A06, otherwise it switches to manual.
E42	Probe AI3 faulty	Triggered if probe AI3, configured as an analogue input, shorts or is cut off or probe limits are exceed (-50°C ...100°C)	OFF	OFF	OFF	
E45	Configuration error	If AI1 is configured as a heating request digital input and AI2 as a cooling request (see analogue inputs), the alarm will be triggered when both inputs are active.	OFF	OFF	OFF	
E46	Over temperature	Triggered if probe AI1 (see analogue inputs) reaches values higher than Pa A25 for a period of time exceeding Pa A26.	OFF ⁴			

³ Only with manual reset

⁴ Only if Pa A17 = 1

Parameters setting

Default configuration

It is an air-air conditioning unit with a summer/winter change-over on the inlet probe.

- The AI1 probe is on the air inlet: it controls the temperature and the summer/winter change-over
- The AI2 probe is on the evaporator and is used to determine the anti-freeze temperature
- The AI3 probe is on the condenser and is used to control condensation and defrosting
- The AI4 probe is on the air inlet and is used for freecooling
- The ID1 input is the high pressure digital input; it is configured as active when the contact is open.
- The ID2 input is the low pressure digital input; it is configured as active when the contact is open.
- The ID3 input is the thermal switch compressor; it is configured as active when the contact is open.
- The ID4 is configured as active when the contact is closed.
- The ID5 input is configured as active when the contact is closed.
- Relay 1 is connected to the compressor
- Relay 2 is connected to the evaporator fan
- Relay 3 is connected to the reversing valve
- Relay 4 is connected to the electric heaters

Defrosting (fig. 01 e fig. 02)

Defrost starts when the exchanger temperature stays cumulatively under the defrosting start temperature for 15 minutes. The defrost start temperature is dynamic and can be seen in the fig. 01.

Defrost times are indicated in the fig. 02.

High temperature alarm

If the temperature of the inlet air is very high this causes considerable overheating. If the air temperature exceeds 42 °C, the instrument signals an alarm without stopping the compressor.

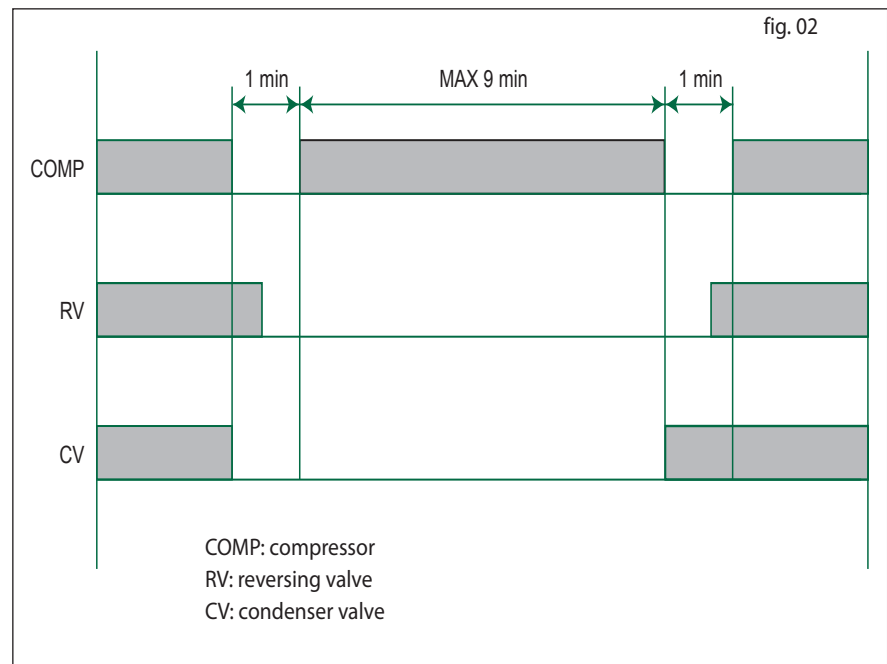
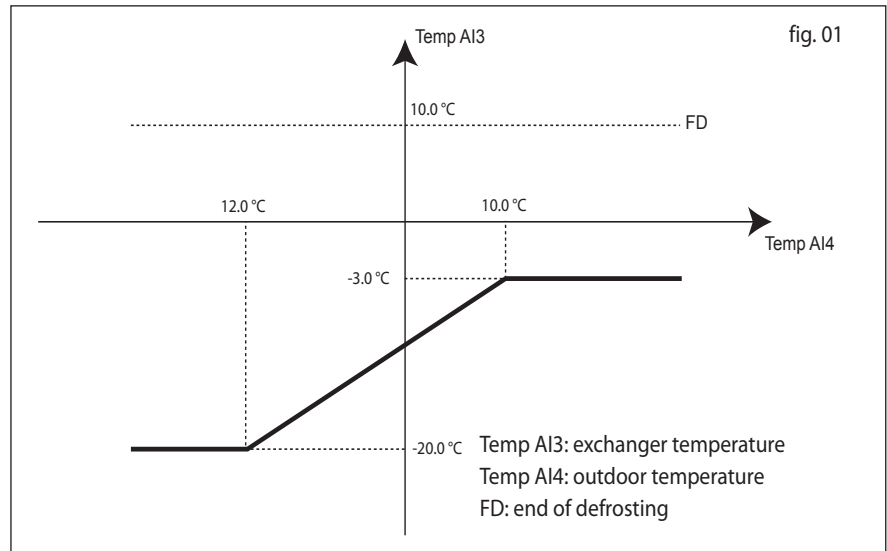

Parameters

Parameters can be set so that the ERT 200 is fully configurable;

Parameters can be changed with:

- keyboard
- Copy Card
- PC (if the special connection and "Param manager" software are available)

DESCRIPTION OF PARAMETER

Configuration parameters

These parameters define the characteristics of the machine. If one or more parameters in this category is changed, the controller must be turned off and on again in order to operate correctly.

Pa G01 "Cooling" set point

Sets the set point in Cooling mode

Pa G02 "Heating" set point

Sets the set point in Heating mode

Pa H01 Maximum "heating" set point

Sets the maximum set point in "heating" mode

Pa H02 Minimum "Heating" set point

Sets the minimum set point in Heating mode

Pa H03 Maximum "Cooling" set point

Sets the maximum set point in Cooling mode

Pa H04 Minimum "cooling" set point

Sets the minimum set point in Cooling mode

Pa H05 Configuration of A11

Configures analogue input A11

• 0= No probe

• 1= Inlet air analogue input

• 2= Heat request digital input

• 3= Temperature control request digital input

• 4= Not used

• 5= On remote keyboard (*)

Pa H06 Configuration of A12

• 0= No probe

• 1= Analogue input

• 2= Cooling request digital input

• 3= Anti-freeze alarm digital input

Pa H07 Configuration of A13

• 0= No probe

• 1= Condensation control analogue input

• 2= 4...20 mA condensation input

• 3= 4...20 mA dynamic set point input

Pa H08 Configuration of A14

• 0= No probe

• 1= Condensation control NTC input

• 2= Multi-functional digital input

• 3= External temperature NTC input

Pa H09 Pressure bottom scale value

Maximum input value; sets the value that corresponds to a current of 20 mA

Pa H10 Polarity of digital input ID1

Pa H11 Polarity of digital input ID2

Pa H12 Polarity of digital input ID3

Pa H13 Polarity of digital input ID4

Pa H14 Polarity of digital input ID5

Pa H15 Polarity of analogue input A11

• 0= Active with closed contact

• 1= Active with open contact

Pa H16 Polarity of analogue input A12

Pa H17 Polarity of analogue input A14

If configured as digital inputs:

• 0= Active with closed contact

• 1= Active with open contact

Pa H18 Configuration of digital input ID3

Pa H19 Configuration of digital input ID4

Pa H20 Configuration of digital input ID5

Pa H21 Configuration of A14 if configured as digital input (Pa H08=2)

• 0= Compressor thermal switch

• 1= Fan thermal switch

• 2= Worn filters

• 3= Remote Heating/Cooling

• 4= Remote ON-OFF

• 5= Thermal switch compressor 2

• 6= Request for second compressor (capacity step)

• 7= damper opening

Pa H22 Configuration of output NO2

• 0= Evaporator fan

• 1= Evaporator fan + HOT START

* activation on compressor regulation demand and not on compressor activation (compressor ON).

**activation on compressor activation (compressor ON); the two digital outputs (compressor and evaporator/internal fan) are always active in parallel without any delay.

Pa H23 Configuration of output relay NO3

• 0= Reversal

• 1= Not used

• 2= second compressor (step)

Pa H24 Configuration of output relay NO4

• 0= Anti-freeze electric heaters

• 1= Not used

• 2= Boiler

Pa H25 Configuration of analogue output

• 0= Not used

• 1= 4-20 mA fan speed output fan

• 2= 0-10 V fan speed output fan

• 3= 4-20 mA fan speed output damper

• 4= 0-10 V fan speed output damper

Pa H26 Configuration of serial protocol (not used)

• 0= Invensys

• 1= Modbus

Pa H27 Selection of operating mode

Selects which input determines Heating/Cooling operating mode

• 0= Selection from keyboard

• 1= Selection from digital input

• 2= Selection from analogue input A14

• 3= Selection from analogue input A11

Pa H28 Presence of heat pump

• 0= Heat pump absent

• 1= Heat pump present

Pa H29 Heating mode set point

If mode selection from the analogue input is enabled, this is the value of A14 below which the control will switch to "heating" mode.

Pa H30 Mode selection differential

If mode selection from the analogue input is enabled, this is the temperature differential for switching to "cooling" mode.

Pa H31 Enable dynamic set point

Enables the function:

• 0= Dynamic set point disabled

• 1= Dynamic set point enabled

Pa H32 Dynamic set point offset in cooling mode

The maximum value that may be added to the set point in "cooling" mode

Pa H33 Dynamic set point offset in heating mode

The maximum value that may be added to the set point in "heating" mode

Pa H34 Outdoor temperature dynamic set point in cooling mode

The temperature above which the set point offset is zero in cooling mode.

Pa H35 Outdoor temperature dynamic set point in heating mode

The temperature above which the set point offset is zero in heating mode.

Pa H36 Outdoor temperature dynamic set point differential in cooling mode

Used to set the for outdoor temperature differential below which the maximum set point offset applies.

Pa H37 Outdoor temperature dynamic set point differential in heating mode

Used to set the for outdoor temperature differential above which the maximum set point offset applies

Pa H38 Reversing valve polarity

- relay ON in cooling mode
- relay ON in heating mode
- Pa H39 Offset AI1
- Pa H40 Offset AI2
- Pa H41 Offset AI3
- This parameter can be used to compensate for the error that may occur between the temperature (or pressure) reading and the actual value.
- Pa H42 Offset AI4
- These parameters can be used to compensate for the error that may occur between the temperature reading and the actual temperature.
- Pa H43 Mains frequency
- 0= Mains frequency: 50 Hz
- 1= Mains frequency: 60 Hz
- Pa H44 Family serial address
- Pa H45 Device serial address
- Used to select the serial address. Both normally set to 0.
- Pa H46 User password
- Can be used to enter the password required to access second level parameters.
- Pa H47 Copy card write password
- The password that must be entered to copy parameters to the copy card.
- Pa H48 Number of compressors per circuit
- 1= 1 Compressor
- 2= 2 Compressors (or 2 steps)
- Pa H49 Enable pressure/temperature based operating
- 0=parameters Pa H07=0 (probe AI3 absent), Pa F01 = 3 (operation in response to request from compressor) are forced.
- 1=temperature-based operating, parameters Pa H07, Pa F01 are forced to: Pa H07= 1 (AI3 temperature probe), Pa F01= 3 (operating in response to request from compressor).
- 2=pressure-based operating, parameters Pa H07, Pa F01 are forced to: Pa H07= 2 (AI3 probe operation based on pressure), F01= 0 (proportional operating).
- = 3 no constraints are set on parameters
- Pa H50 Compressor start-up sequence
- 0=compressors start according to operating hours (balancing of operating hours)
- 1=compressor 1 is started first and then compressor (or capacity step) 2 (fixed sequence).
- Pa H51 Compressor 2 or capacity step polarity
- 0= relay ON if compressor 2/capacity step ON
- 1= relay ON if compressor 2/capacity step OFF
- Pa H52 Selection of degrees °C or °F
- 0= degrees °C
- 1= degrees °F

Pa H53 Display of air/air machine SET POINT

For a simpler user interface in air-air versions, by setting parameter Pa H53 = 1 the set point for the mode selected is displayed normally

Pa H54 Customer code 1

This is a number ranging from 0 to 999 that the user can assign for internal use.

Pa H55 Customer code 2

This is a number ranging from 0 to 999 that the user can assign for internal use.

Pa H56 Polarity of alarm relay

• 0 = output is active (contact closed) when there is an alarm

• 1 = the contact is open with the same conditions

Pa H57 Enable alarm relay in off position

• 0 = inactive alarm output in OFF or standby mode or remote off

• 1 = active alarm output in OFF or standby mode or remote off

Pa H58 Enables change-over from keyboard in hysteresis of analogue change-over

• 0 = change-over is not possible in hysteresis

• 1 = change-over is possible in hysteresis

Alarm parameters

Pa A01 Low pressure pressure switch by-pass time.

Determines the delay between starting up the compressor and starting up the low pressure digital alarm diagnostics. It is expressed in seconds

Pa A02 Number of low pressure events per hour

Used to set the number of low pressure digital alarm events per hour. If exceeded, the system will switch from automatic reset to manual reset.

Pa A03 Bypass time for worn filters activated by evaporator fan

Used to set a delay in triggering off the worn filter digital alarm activated by the evaporator fan. It is expressed in seconds

Pa A04 Duration of active worn filters input

Used to set a period of time during which the worn filter digital input must remain active. When this period has elapsed, the alarm is generated. The timer starts after the worn filters by-pass time. It is expressed in seconds.

Pa A05 Duration of inactive worn filters

input

Used to set a period of time during which the worn filter digital input must remain inactive. When this period has elapsed, the alarm is deactivated. It is expressed in seconds.

Pa A06 Number of worn filter events per hour

Used to set the number of worn filter digital alarm events per hour. If the number is exceeded, the alarm is switched from automatic to manual reset. If the alarm is in manual reset mode, the fan is shut down.

Pa A07 By-pass time for compressor thermal switch activated by compressor

Used to set a delay for triggering the compressor thermal switch alarm activated by the compressor. It is expressed in seconds

Pa A08 Number of compressor 1 and 2 thermal switch alarm events per hour

Used to set the number of compressor thermal switch alarm events per hour. If the number is exceeded, the alarm is switched from automatic to manual reset.

Pa A09 Number of condensing fan thermal switch events per hour

Used to set the number of fan thermal switch alarm events per hour. If the number is exceeded, the alarm is switched from automatic to manual reset.

Pa A10 Anti-freeze alarm by-pass time

Determines the delay between turning on the machine and activation of the anti-freeze alarm; it is enabled only in heating mode. It is expressed in minutes.

Pa A11 Anti-freeze alarm set point

Used to set the temperature below which the anti-freeze alarm is triggered.

Pa A12 Anti-freeze alarm differential

Used to set the anti-freeze alarm differential.

Pa A13 Number of anti-freeze alarm events per hour

Used to set the number of anti-freeze alarm events per hour. If the number is exceeded, the alarm is switched from automatic to manual reset.

Pa A14 Enable minimum alarm during defrosting

Enables the minimum alarm during defrosting. If 0 the minimum alarm is disabled during defrosting.

Pa A15 Over-temperature set point

Sets the temperature value AI1. If exceeded, the over-temperature alarm E46 is triggered.

Pa A16 Over-temperature ON duration

Determines the duration of the condition AI1>A25. If exceeded, alarm E46 is triggered.

Pa A17 Turns compressor OFF if over-temperature

If set to 1 it turns off the compressor if an over-temperature alarm is generated

Pa A18 Select anti-freeze alarm probe

- 0 = probe AI1
- 1 = probe AI2

Compressor parameters

Pa C01 OFF-ON safety time

The minimum period of time that must elapse between turning off the compressor and turning it on again. It is expressed in tens of seconds.

Pa C02 ON-ON safety time

The minimum period of time that must elapse between turning the compressor on and turning it on again. It is expressed in tens of seconds.

Pa C03 Temperature control hysteresis in Cooling mode

Used to select the activation differential in Cooling mode.

Pa C04 Temperature control hysteresis in Heating mode

Used to select the activation differential in Heating mode.

Pa C05 Regulation step intervention differential

Used to set a temperature differential in relation to the set point beyond which the second step is activated.

Pa C06 Interval between compressor 1 – compressor 2 start-up (step)

Used to set a delay between turning on the first and the second step

Pa C07 Interval between compressor 1 – compressor 2 shut-down (step)

Used to set a delay between turning off the first and the second step.

Fan parameters

Pa F01 Fan output configuration

- 0: proportional condensation control TK output
- 1: ON-OFF TK output
- 2: anti-freeze electric heater output for water-water machines with gas reversal
- 3: TK ON-OFF output on compressor

Pa F26 Freecooling offset in cooling mode

Moves the freecooling set point in relation to the cooling set point

Pa F27 Freecooling proportional band in Cooling mode

Freecooling control band

Pa F28 Freecooling offset in heating mode

Moves the freeheating set point in relation to the heating set point

Pa F29 Freeheating band in Heating mode

Freeheating control band

Pa F30 Outdoor/internal temperature offset in freecooling and freeheating

Offset in controller that compares outdoor and internal temperature

Pa F31 Minimum damper opening

Minimum damper opening value

Pa F32 Freecooling shut-down set point

Outdoor temperature that shuts down freecooling

Pa F33 Freecooling shut-down offset

Controller offset that shuts down freecooling

Evaporator fan parameters

Pa P01 Evaporator fan operating mode

May be used to determine the pump or fan operating mode

- 0= continuous operation
- 1= fan shuts down as the same time as the compressor
- 2= continuous operating of fan in cooling mode, on request in heating mode
- 3= continuous operating of fan in cooling mode, on request in heating mode
- 4= continuous operating of fan in heating mode, on request in cooling mode

Pa P02 Delay between fan ON and compressor ON

It sets a delay between the start up of the fan and the compressor. It is expressed in seconds.

Pa P03 Delay between compressor OFF and fan OFF

It sets a delay between the shutdown of the unit and the fan. It is expressed in seconds.

Anti-freeze/boiler parameters

Pa r01 Configuration of electric heaters in Defrost mode

Determines electric heater operation when the defrost function is activated

- 0=On only when requested by temperature controller
- 1=Always on in Defrost mode

Pa r02 Configuration of electric heaters activated in Cooling mode

Determines electric heater operating in Cooling mode

- 0=Off in Cooling mode

• 1=On in cooling mode (depending on the anti-freeze electric heater regulation algorithm)

Pa r03 Configuration of electric heaters activated in Heating mode

Determines electric heater operating in Heating mode

- 0=Off in Heating mode
- 1=On in Heating mode (depending on the anti-freeze electric heaters regulation algorithm)

Pa r04 Configuration of anti-freeze electric heater control probe in heating mode

Determines the control probe of the electric heaters in Heating mode

- 0=Controls on probe AI1
- 1=Controls on probe AI2

Pa r05 Configuration of anti-freeze electric heater control probe in cooling mode

Determines the control probe of the electric heaters in Cooling mode

- 0=Controls on probe AI1
- 1=Controls on probe AI2

Pa r06 Configuration of electric heaters in OFF or stand-by mode

Determines the status of electric heaters when the unit is in OFF or Stand-by mode

- 0=Always off in OFF or stand-by
- 1=On in OFF or stand-by (depending on the anti-freeze electric heater control algorithm)

Pa r07 Anti-freeze electric heater set point in Heating mode

È il valore di temperatura, in heating, al di sotto del quale vengono attivate le resistenze antigelo.

Pa r08 Anti-freeze electric heater set point in Cooling mode

It represents the temperature, in Heating mode, below which anti-freeze electric heaters are activated.

Pa r09 Maximum set point limit for anti-freeze electric heaters

Sets the maximum set point for anti-freeze electric heaters.

Pa r10 Minimum set point limit for anti-freeze electric heaters

Sets the minimum set point for anti-freeze electric heaters.

Pa r11 Anti-freeze electric heater hysteresis

Pa r12 Enable heat pump shut-down

- 0= heat pump always on
- 1 =heat pump shut down when outdoor temperature is too cold

Pa r13 Outdoor temperature set point for deactivation of heat pump

The temperature below which the heat pump is turned of.

Pa r14 Differential for deactivation of heat

pump

The differential for deactivation of the heat pump. If the outdoor temperature exceeds Pa r14+Pa r13 the heat pump is turned back on.

Pa r15 Enable integrated electric heater control

If this parameter =1 the electrical heaters also act as integrated heaters.

If not (Pa r15=0), the electrical heaters only perform the anti-freeze function

Defrost parameters

Pa d01 Defrost enabled

0= defrost function disabled

1= defrost function enabled

Pa d02 Defrost start temperature/pressure

The temperature/pressure below which the defrost cycle is activated.

Pa d03 Defrost interval (response time)

The period of time during which the probe remains below the defrost start temperature/pressure. It is expressed in minutes.

Pa d04 Defrost end temperature/pressure

Temperature/pressure above which defrosting starts.

Pa d05 Maximum defrost time (time out)

Maximum duration of defrosting. It is expressed in minutes.

Pa d06 Compressor-reversing valve wait time (anti-bleeding)

Wait time between compressor shut-down and reversal of the 4-way valve at the beginning of the defrost cycle.

Pa d07 Drainage time

Wait time between compressor shut-down and reversal of the 4-way valve at the end of the defrost cycle.

Pa d08 Temperature at which defrost starts if Pa H49= 1

À la temperatura al di sotto la quale viene avviato il ciclo di sbrinamento.

Pa d09 Temperature at which defrost ends if Pa H49= 1

Temperature above which the defrost cycle is ended.

Pa d10 Enable defrost compensation

Refer to temperature compensation at start of defrosting

Pa d11 Defrost temperature/pressure compensation offset

Refer to temperature compensation at start of defrosting

Pa d12 Defrost temperature/pressure compensation set point

VRefer to temperature compensation at start of defrosting

Pa d13 Defrost temperature/pressure compensation delta

Refer to temperature compensation at start of defrosting

TP t03 Cooling circuit high pressure

To express the pressure value in bar divide the read valued by 100.

TP t04 External temperature

External temperature display

Parameters table

The following table shows all the control parameters.

After every parameter change, the control device must be turned off and re-activated to guarantee its correct operation.

PARAMETERS TABLE					
Par.	Description	Value	Limits	Unit	Fast Values
Pa H01	Maximum set point during heating	250	Pa H02 ÷ 90.0	°C	24
Pa H02	Minimum set point during heating	160	-40.0 ÷ Pa H01	°C	16
Pa H03	Maximum set point during cooling	240	Pa H04 ÷ 90.0	°C	30
Pa H04	Minimum set point during cooling	200	-40.0 ÷ Pa H03	°C	18
Pa H05	Configuration of AI1 (EXHAUST AIR PROBE)	1	0 ÷ 5 (*)	Num	1
Pa H06	Configuration of AI2 (NO PROBE)	1	0 ÷ 3	Num	0
Pa H07	Configuration of AI3 (PRESSURE PROBE)	1	0 ÷ 5	Num	2
Pa H08	Configuration of AI4 (EXTERNAL PROBE)	3	0 ÷ 3	Num	3

continue

Par.	Description	Value	Limits	Unit	Fast Values
Pa H09	Pressure bottom scale value	300	0-350	kPa*10	300
Pa H10	Polarity ID1 HP (Active if open)	1	0 ÷ 1	Flag	1
Pa H11	Polarity ID2 LP (Active if open)	1	0 ÷ 1	Flag	1
Pa H12	Polarity ID3 Fan TH (Active if open)	1	0 ÷ 1	Flag	1
Pa H13	Polarity ID4 Remote OFF (Active if open)	1	0 ÷ 1	Flag	1
Pa H14	Polarity ID5 Summer Winter (if H27=1 -Open= WINTER - Close=SUMMER)	1	0 ÷ 1	Flag	1
Pa H15	Polarity AI1	0	0 ÷ 1	Flag	0
Pa H16	Polarity AI2	0	0 ÷ 1	Flag	0
Pa H17	Polarity AI4	0	0 ÷ 1	Flag	0
Pa H18	Configuration ID3 Fan TH	0	0 ÷ 7	Num	1
Pa H19	Configuration ID4 Remote ON/OFF	1	0 ÷ 7	Num	4
Pa H20	Configuration ID5 Summer Winter	4	0 ÷ 7	Num	3
Pa H21	Configuration AI4 (NOT USED if digital input)	0	0 ÷ 7	Num	2
Pa H22	Configuration relay 2 Post Ventilation	0	0 ÷ 1	Num	1
Pa H23	Configuration relay 3 Reversing Valve	0	0 ÷ 2	Num	0
Pa H24	Configuration relay 4 Integration	0	0 ÷ 2	Num	0
Pa H25	Configuration analogue output Freecooling	4	0 ÷ 2	Num	3
Pa H26	Configuration of serial protocol	0	0 ÷ 1	Num	1
Pa H27	Selection of operating mode H27=1 remote SUMMER WINTER	3	0 ÷ 3	Num	0
Pa H28	Presence of heat pump	1	0 ÷ 1	Flag	1
Pa H29	Heating mode set point	18	0 ÷ 255	°C	20
Pa H30	Mode selection differential	85	0 ÷ 25.5	°C	0,7
Pa H31	Enables dynamic set point	1	0 ÷ 1	Flag	0
Pa H32	Dynamic set point off set in cooling mode	50	-12.7 ÷ 12.7	°C	1,0
Pa H33	Dynamic set point off set in heating mode	0	-12.7 ÷ 12.7	°C	1,0
Pa H34	Outdoor temperature dynamic set point in cooling mode	190	0 ÷ 255	°C	4
Pa H35	Outdoor temperature dynamic set point in heating mode	0	0 ÷ 255	°C	8
Pa H36	Outdoor temperature dynamic set point differential in cooling mode	200	-25.5 ÷ 25.5	°C	5,0
Pa H37	Outdoor temperature dynamic set point differential in heating mode	0	-25.5 ÷ 25.5	°C	5,0
Pa H38	Reversing valve polarity	0	0 ÷ 1	Flag	0
Pa H39	Offset AI1	0	-12.7 ÷ 12.7	°C	0,0
Pa H40	Offset AI2	0	-12.7 ÷ 12.7	°C	0
Pa H41	Offset AI3	0	-127 ÷ 127	°C/10-kPa*10	0
Pa H42	Offset AI4	0	-12.7 ÷ 12.7	°C	0
Pa H43	Mains frequency	0	0 ÷ 1	Flag	0
Pa H44	Family serial address	0	0 ÷ 14	Num.	0
Pa H45	Devide serial address	0	0 ÷ 14	Num.	0
Pa H46	User password	0	0 ÷ 255	Num.	0
Pa H47	Copy card write password	1	0 ÷ 255	Num.	1
Pa H48	Number of compressors per circuit	1	1 ÷ 2	Num.	1
Pa H49	Enables pressure/temperature based operating	3	0 ÷ 2	Num.	2
Pa H50	Compressor start-up sequence	1	0 ÷ 1	Num.	0
Pa H51	Compressor 2 or capacity step polarity	0	0 ÷ 1	Num.	0
Pa H52	Selection of degrees °C or °F	0	0 ÷ 1	Num.	0
Pa H53	Display of air/air machine SET POINT	0	0 ÷ 1	Num.	0
Pa H54	Customer code 1	0	0 ÷ 999	Num.	0
Pa H55	Customer code 2	0	0 ÷ 999	Num.	0
Pa H56	Polarity of alarm relay	1	0 ÷ 1	Flag	0
Pa H57	Enables alarm relay in off position	0	0 ÷ 1	Flag	1
Pa H58	Enables changeover from keyboard in hysteresis of analogue changeover	0	0 ÷ 1	Flag	0

ALARM PARAMETERS TABLE					
Par.	Description	Value	Limits	Unit	Fast Values
Pa A01	Low pressure switch bypass time from compressor	0	0 ÷ 255	Seconds	20
Pa A02	Number of low pressure events per hour	3	0 ÷ 255	Num	4
Pa A03	Bypass time for worn filters activated by fan	0	0 ÷ 255	Seconds	10
Pa A04	Duration of active worn filters input	30	0 ÷ 255	Seconds	15
Pa A05	Duration of inactive worn filters input	0	0 ÷ 255	Seconds	15
Pa A06	Number of worn filter events per hour	0	0 ÷ 255	Num	5
Pa A07	Compressor thermal switch bypass time activated by compressor	0	0 ÷ 255	Seconds	5
Pa A08	Number of compressor 1 and 2 thermal switch alarm events per hour	0	0 ÷ 255	Num	2
Pa A09	Number of fan thermal switch events per hour	0	0 ÷ 255	Num	2
Pa A10	Anti-frost alarm bypass after ON-OFF	0	0 ÷ 255	Minutes	5
Pa A11	Anti-freeze alarm set point	-4	-127 ÷ 127	°C	2
Pa A12	Anti-freeze alarm hysteresis	0	0 ÷ 25.5	°C	1
Pa A13	Number of anti-freeze alarm events per hour	255	0 ÷ 255	Num	2
Pa A14	Enables minimum alarm during defrosting	1	0 ÷ 1	Flag	0
Pa A15	Over-temperature set point	42	0 ÷ 255	°C	50
Pa A16	Over-temperature ON duration	0	0 - 255		6
Pa A17	Turns loads OFF in over-temperature	0	0 ÷ 1	Flag	0
Pa A18	Select 0=A11 anti-freeze alarm probe	1	0 ÷ 1	Flag	0

COMPRESSOR PARAMETERS TABLE					
Par.	Description	Value	Limits	Unit	Fast Values
Pa C01	ON-OFF safety time	3	0 ÷ 255	Seconds*10	18
Pa C02	ON-ON safety time	36	0 ÷ 255	Seconds*10	20
Pa C03	Temperature control hysteresis in cooling mode	15	0 ÷ 25.5	°C	2
Pa C04	Temperature control hysteresis in heating mode	15	0 ÷ 25.5	°C	1,5
Pa C05	Regulation step intervention differential	20	0 ÷ 25.5	°C	2
Pa C06	Interval between compressor 1 - compressor 2 start up	0	0 ÷ 255	Seconds	20
Pa C07	Interval between compressor 1 - compressor 2 shut down	0	0 ÷ 255	Seconds	5

ELECTRIC HEATER PARAMETERS TABLE					
Par.	Description	Value	Limits	Unit	Fast Values
Pa r01	Configuration of electric heater in defrost mode	1	0 ÷ 1	Flag	1
Pa r02	Configuration of electric heater activated in cooling mode	1	0 ÷ 1	Flag	0
Pa r03	Configuration of electric heater activated in heating mode	1	0 ÷ 1	Flag	1
Pa r04	Configuration of anti-freeze electric heater control probe in heating mode	1	0 ÷ 1	Flag	0
Pa r05	Configuration of anti-freeze electric heater control probe in cooling mode	1	0 ÷ 1	Flag	0
Pa r06	Configuration of electric heater in OFF or stand by mode	1	0 ÷ 1	Flag	0
Pa r07	Anti-freeze electric heater set point in heating mode	8	Pa r09 ÷ Pa r10	°C	2
Pa r08	Anti-freeze electric heater set point in cooling mode	8	Pa r09 ÷ Pa r10	°C	2
Pa r09	Maximum set point of anti-freeze electric heaters	15	Pa r10 ÷ 127	°C	10
Pa r10	Minimum set point of anti-freeze electric heaters	0	-127 ÷ Pa r09	°C	0
Pa r11	Anti-freeze electric heater hysteresis	30	0 ÷ 25.5	°C	1
Pa r12	Enables heat pump shut down	1	0 ÷ 1	Flag	0
Pa r13	Outdoor temperature set point for deactivation of heat pump	-13	-127 ÷ 127	°C	-5
Pa r14	Differential for deactivation of heat pump	20	0 ÷ 25.5	°C	2
Pa r15	Activation of integrated electric heaters	1	0 ÷ 1	Flag	1

FAN PARAMETERS TABLE					
Par.	Description	Value	Limits	Unit	Fast Values
Pa F01	Fan output mode	1	0 ÷ 3	Num.	0
Pa F02	Fan pick up time	30	0 ÷ 255	Seconds/10	20
Pa F03	Fan phase shift	8	0 ÷ 100	μs*200	30
Pa F04	Duratin of Triac activation inpulse	5	0 ÷ 255	μs*200	8
Pa F05	Operation in response to compressor request	0	0 ÷ 1	Flag	0
Pa F06	Minimum speed in cooling mode	40	0 ÷ 100	%	20
Pa F07	Maximum silent speed in cooling mode	100	0 ÷ 100	%	80
Pa F08	Minimum fan speed temperature/pressure set point in cooling mode	340	-500 ÷ 800	°C/10 – kPa*10	100
Pa F09	Proportional band in cooling mode	100	0 ÷ 255	°C/10 – kPa*10	40
Pa F10	Cut-off differential	40	0 ÷ 255	°C/10 – kPa*10	20
Pa F11	Cut-off hysteresis	30	0 ÷ 255	°C/10 – kPa*10	10
Pa F12	Cut-off bypass time	180	0 ÷ 255	Seconds	10
Pa F13	Maximum speed in cooling mode	100	0 ÷ 100	%	100
Pa F14	Maximum fan speed temperature/pressure set point in cooling mode	470	-500 ÷ 800	°C/10 – kPa*10	180
Pa F15	Minimum speed in heating mode	40	0 ÷ 100	%	20
Pa F16	Maximum silent speed in heating mode	100	0 ÷ 100	%	80
Pa F17	Minimum fan speed temperature/pressure set point in heating mode	100	-500 ÷ 800	°C/10 – kPa*10	180
Pa F18	Proportional band in heating mode	100	0 ÷ 255	°C/10 – kPa*10	40
Pa F19	Maximum speed in heating mode	100	0 ÷ 100	%	100
Pa F20	Maximum fan speed temperature/pressure set point in heating mode	-100	-500 ÷ 800	°C/10 – kPa*10	120
Pa F21	Not used	0	-	-	
Pa F22	Not used	0	-	-	
Pa F23	Hot Start set point	0	0 ÷ 255	°C	18
Pa F24	Hot Start hysteresis	0	0 ÷ 25.5	°C	2
Pa F25	Pre-ventilation in cooling mode	0	0 ÷ 255	Seconds	0
Pa F26	Freecooling offset in cooling mode	30	0 ÷ 25.5	°C	2
Pa F27	Freecooling proportional band in cooling mode	30	0 ÷ 25.5	°C	2
Pa F28	Freecooling offset in heating mode	30	0 ÷ 25.5	°C	2
Pa F29	Freeheating band in heating mode	30	0 ÷ 25.5	°C	2
Pa F30	Outdoor/internal temperature offset in freecooling and freeheating	10	0 ÷ 25.5	°C	10
Pa F31	Minimum damper opening	20	0 ÷ 100	%	0
Pa F32	Freecooling shut-down set point	8	-127 ÷ 127	°C	11
Pa F33	Freecooling shut-down offset	10	0 ÷ 25.5	°C	2

EVAPORATOR FAN PARAMETERS					
Par.	Description	Value	Limits	Unit	Fast Values
Pa P01	Evaporator fan operating mode	0	0 ÷ 4	Num.	0
Pa P02	Delay between fan ON and compressor ON	30	0 ÷ 255	Seconds	0
Pa P03	Delay between compressor OFF and fan OFF	30	0 ÷ 255	Seconds	240

DEFROST PARAMETERS TABLE					
Par.	Description	Value	Limits	Unit	Fast Values
Pa d01	Defrost enabled	1	0 ÷ 1	Flag	1
Pa d02	Defrost start temperature/pressure	-30	-500 ÷ 800	°C/10 - kPa*10	30
Pa d03	Defrost interval	15	0 ÷ 255	Minutes	1
Pa d04	Defrost end temperature/pressure	100	-500 ÷ 800	°C/10 - kPa*10	100
Pa d05	Maximum defrost time	9	0 ÷ 255	Minutes	5
Pa d06	Compressor - reversing valve wait time	60	0 ÷ 255	Seconds	30
Pa d07	Drainage time	60	0 ÷ 255	Seconds	30
Pa d08	Temperature at which defrost starts if Pa H49= 1	100	-50.0 ÷ 80.0	°C/10	8
Pa d09	Temperature at which defrost ends if Pa H49= 1	150	-500 ÷ 80.0	°C/10	15
Pa d10	Enables defrost compensation	1	0 ÷ 1	Flag	0
Pa d11	Defrost temperature/pressure compensation offset	-170	-255 ÷ 255	°C/10 - kPa*10	20
Pa d12	Defrost temperature/pressure compensation set point	10	-127 ÷ 127	°C	2
Pa d13	Defrost temperature/pressure compensation delta	-220	-25.5 ÷ 25.5	°C	-3

Technical characteristics

General Technical Data

The unit must be powered by an adequate transformer with the following characteristics:

- Primary voltage: 230V~±10%; 110V~±10%
- Secondary voltage: 12V~
- Supply frequency: 50Hz; 60Hz
- Power: 5VA;

	Typical	Min.	Max.
Supply voltage	12V~	10V~	14V~
Supply frequency	50Hz/60Hz	---	---
Power	5VA	---	---
Insulation class	1	---	---
Operating ambient temperature	25°C	-10°C	60°C
Operating ambient temperature (non-condensing)	30%	10%	90%
Storage ambient temperature	25°C	-20°C	85°C
Storage ambient humidity (non-condensing)	30%	10%	90%

Electromechanical and I/O characteristics

120/240 V digital outputs	<ul style="list-style-type: none"> • 4 relays (5 relays for ERT 215A-215BA) 2A ¼ hp 240V~; 1/8 hp 120V~ • 1 2A Triac (ERT 210-210B)
Analogue inputs	<ul style="list-style-type: none"> • 3 temperature sensors, measuring range -30°C ÷ 90°C; • 1 configurable input: 4...20 mA transducer or temperature sensor, range -30°C ÷ 90°C;
Digital inputs	<ul style="list-style-type: none"> • 5 voltage free digital inputs
Terminals and connectors	<ul style="list-style-type: none"> • 1 9-way snap-on high voltage connector AWG 16-28 • 1 16-way snap-on high voltage connector, pitch 4.2, AWG 16-28 • 1 5-way p2.5 5-way connector with remote control and copy card programming, AWG 24-30 • 1 2/3-way connector remote keyboard AWG 22-30;
Display and LEDs	<ul style="list-style-type: none"> • 3 digits + sign; • 5 red LEDs
Buttons	<ul style="list-style-type: none"> • 2 buttons
Serials	<ul style="list-style-type: none"> • 1 serial 9600 • 1 serial 2400

Dimensions	Front panel 76x34 mm, depth 58 mm
Casing	PC+ABS plastic resin with V0 rated fire protection
Installation	Panel-mounted with drilling template 71x29 mm (+0.2/-0.1 mm)

Standards

The product complies with the following European Union Directives:

- EU Directive 73/23/EEC and subsequent amendments
- EU Directive 89/336/EEC and subsequent amendments and is compliant with the following harmonized standards:

- LOW VOLTAGE: EN60730
- EMISSIONS: EN50081-1 (EN55022)
- IMMUNITY: EN50082-2 (IEC 1000-4-2/3/4/5)

Use of the control device

To ensure safety, the controller must be installed and operated in accordance with the instructions supplied, and access to high voltage components must be prevented under regular operating conditions. The device shall be properly protected against water and dust and shall be accessible by using a tool only. The device is suitable for incorporation in a household appliance and/or similar air conditioning device.

According to the reference regulations, it is classified:

- In terms of construction, as an automatic electronic control device to be incorporated with independent assembly or integrated;

- In terms of automatic operating features, as a type 1 action control device, with reference to manufacturing tolerances and drifts;
- As a class 2 device in relation to protection against electrical shock;
- As a class A device in relation to software structure and class.

Forbidden use

Any use other than the permitted use is forbidden.

Please note that relay contacts supplied are functional and are subject to fault (in that they are controlled by an electronic component and be shorted or remain open); protection devices recommended by product standards or suggested by common sense in response to evident safety requirements shall be implemented outside of the instrument.

Responsibilities and residual risk

Fast SpA shall not be liable for any damages deriving from:

- installation/use other than that prescribed which does not comply with the safety standards specified in the regulations and/or those given herein;

- use on equipment that does not guarantee adequate protection against electric shock, water or dust when assembled.
- use on equipment that allows dangerous parts to be accessed without the use of tools;

- installation/use on equipment that is not compliant with the standards and regulations in force.

0208-6180549-rev.02

Technical data shown in this booklet are not binding.
FAST S.p.A. shall have the right to introduce at any time whatever
modifications deemed necessary to the improvement of the product.



FAST S.p.A. TRATTAMENTO
DELL'ARIA
35044 Montagnana (PD) - Italy
Via Luppia Alberi, 170
Tel. (+39) 0429 806311 - Fax 0429 806340
E-mail: info@fastaer.com
<http://www.fastaer.com>

